

(12) **UK Patent**

(19) **GB**

(11) **2541228**

(13) **B**

(45) Date of B Publication

15.07.2020

(54) Title of the Invention: **Quick fit connector**

(51) INT CL: **F02M 55/00** (2006.01) **F02M 55/02** (2006.01) **F02M 61/14** (2006.01) **F02M 69/46** (2006.01)
F16L 37/00 (2006.01)

(21) Application No: **1514389.4**

(22) Date of Filing: **13.08.2015**

(43) Date of A Publication **15.02.2017**

(72) Inventor(s):

Daniele Carboni
Riccardo Rossi

(73) Proprietor(s):

GM Global Technology Operations LLC
PO Box 300, 300 Renaissance Center, Detroit,
48265-3000, United States of America

(56) Documents Cited:

EP 1394402 A2 **WO 2015/068867 A1**
WO 2005/059426 A1 **US 20100244302 A1**

(58) Field of Search:

As for published application 2541228 A viz:
INT CL **F02M**
Other: **WPI; EPODOC**
updated as appropriate

Additional Fields

INT CL **F16L**
Other: **None**

(74) Agent and/or Address for Service:

Greg Sach
Kopf, Westenberger, Wachenhausen, Briennerstr. 11,
80333, München, Germany

GB 2541228 B

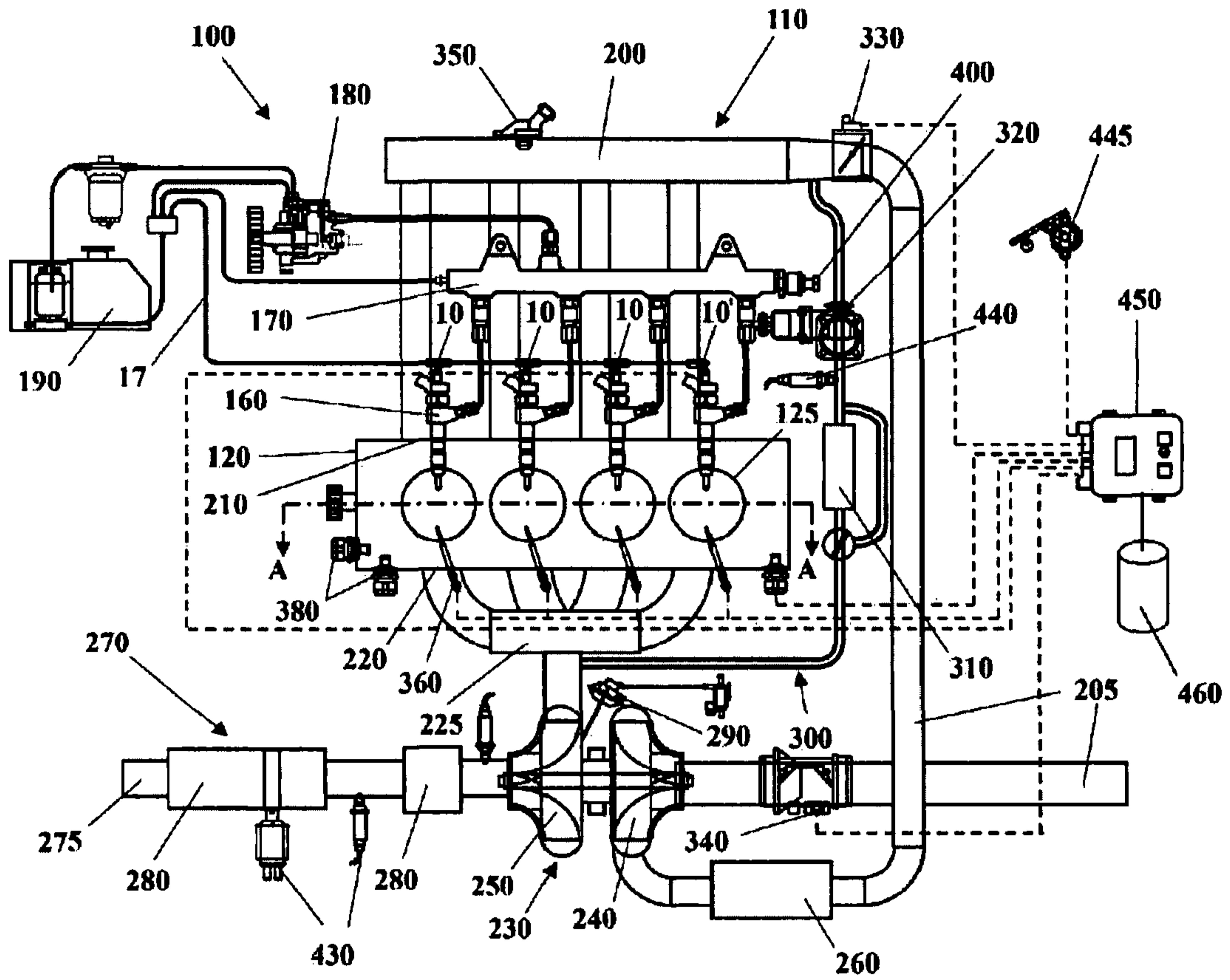

FIG. 1

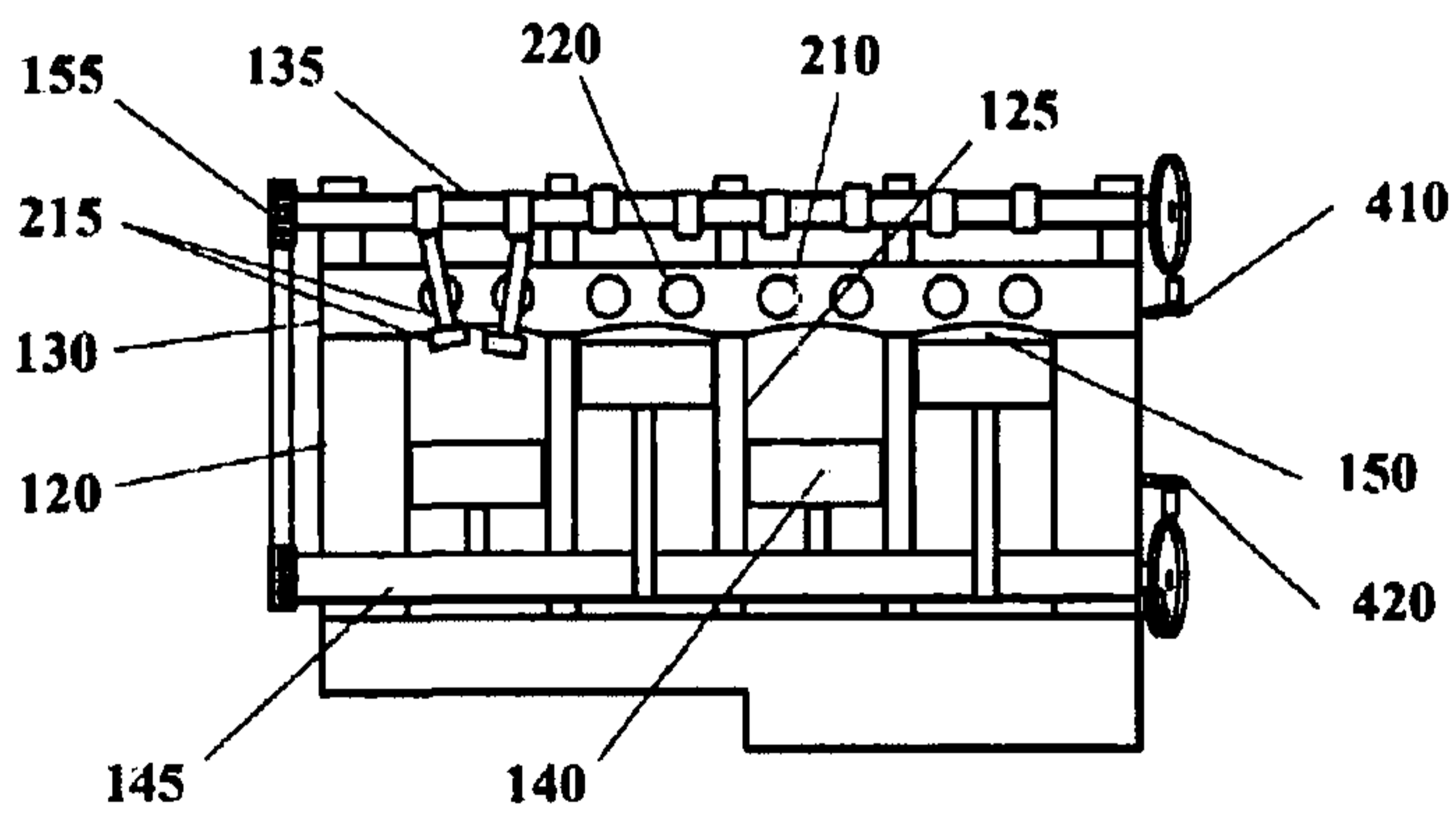

FIG. 2

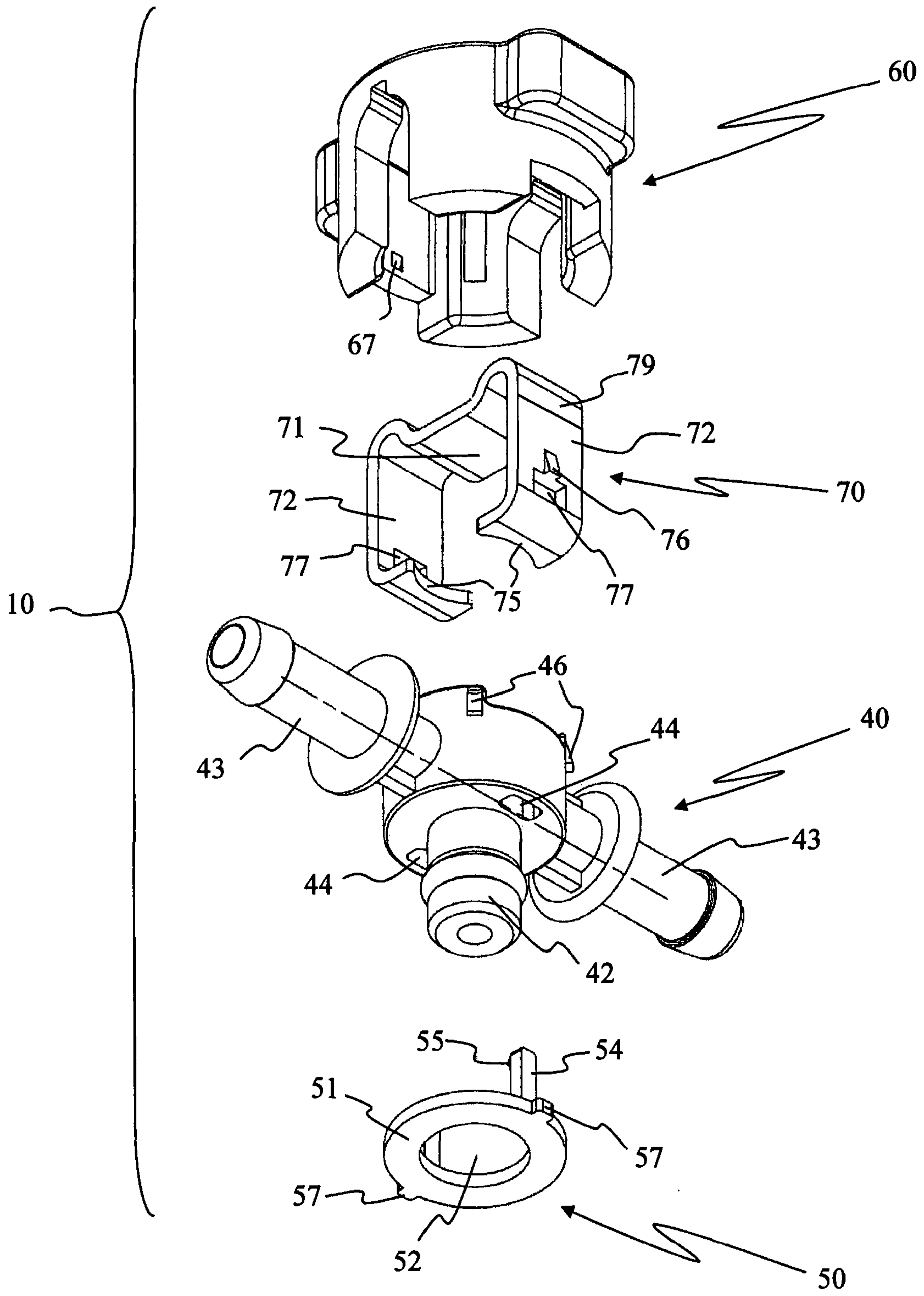

Fig. 3

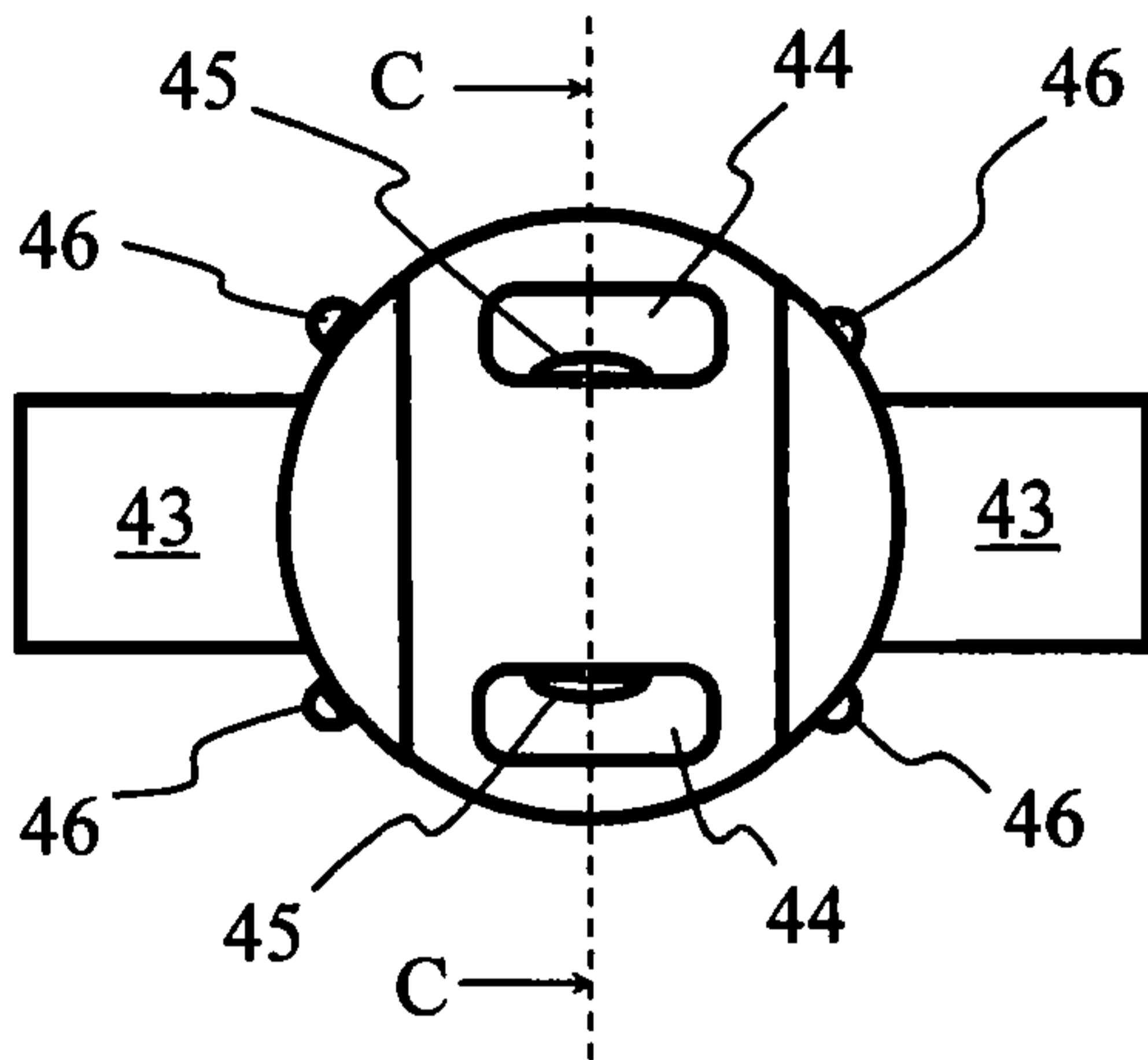

Fig. 4A

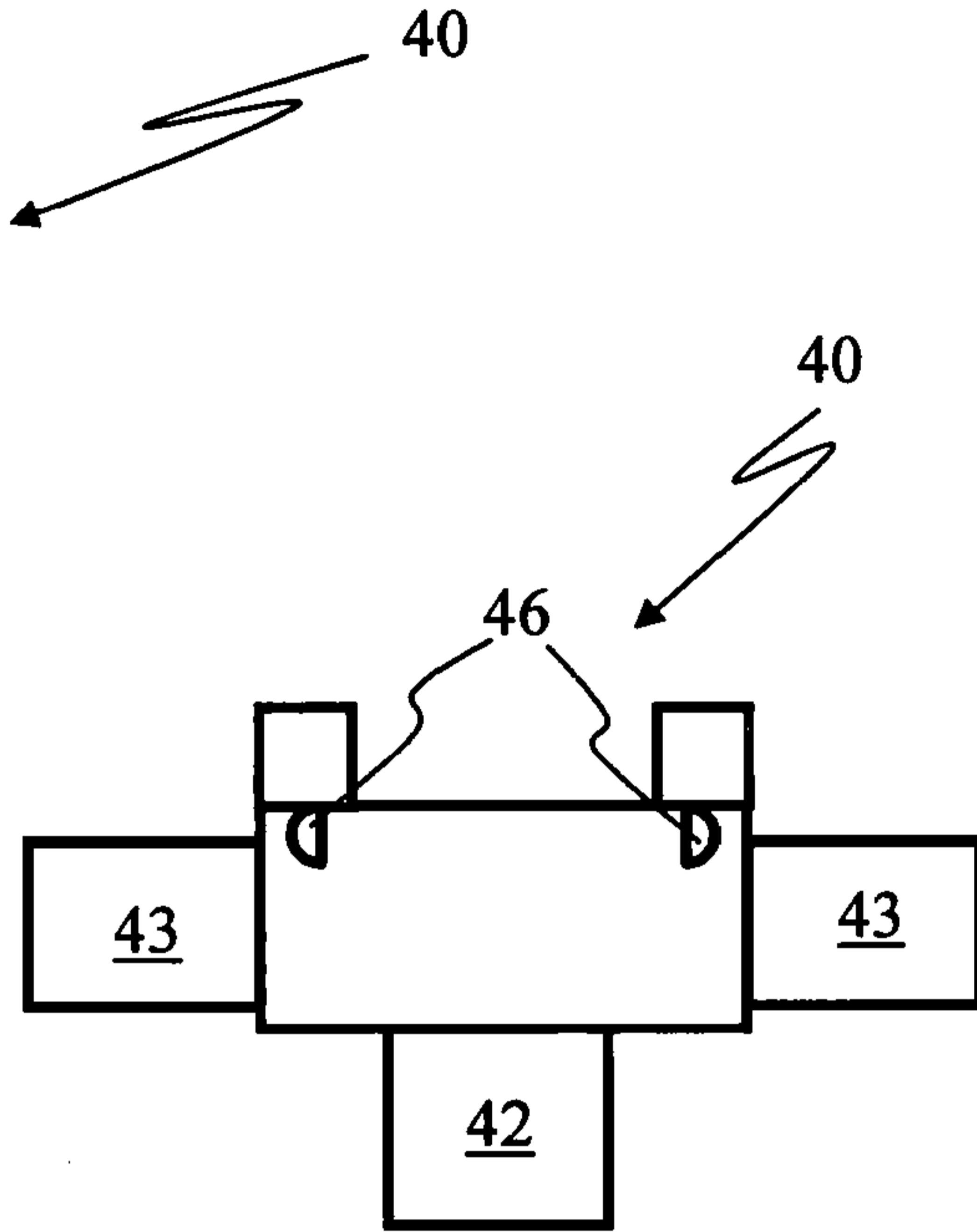

Fig. 4B

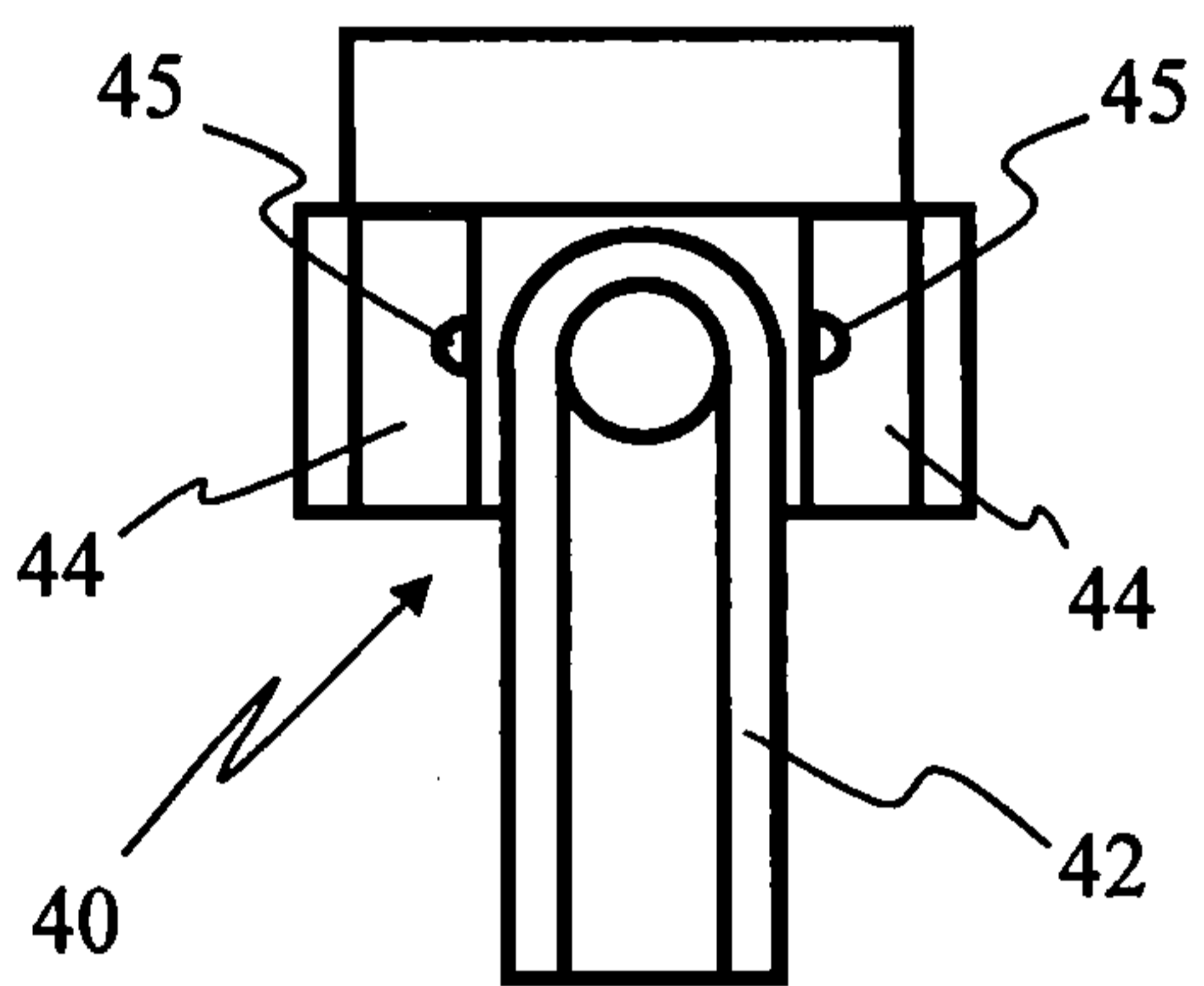

Fig. 4C

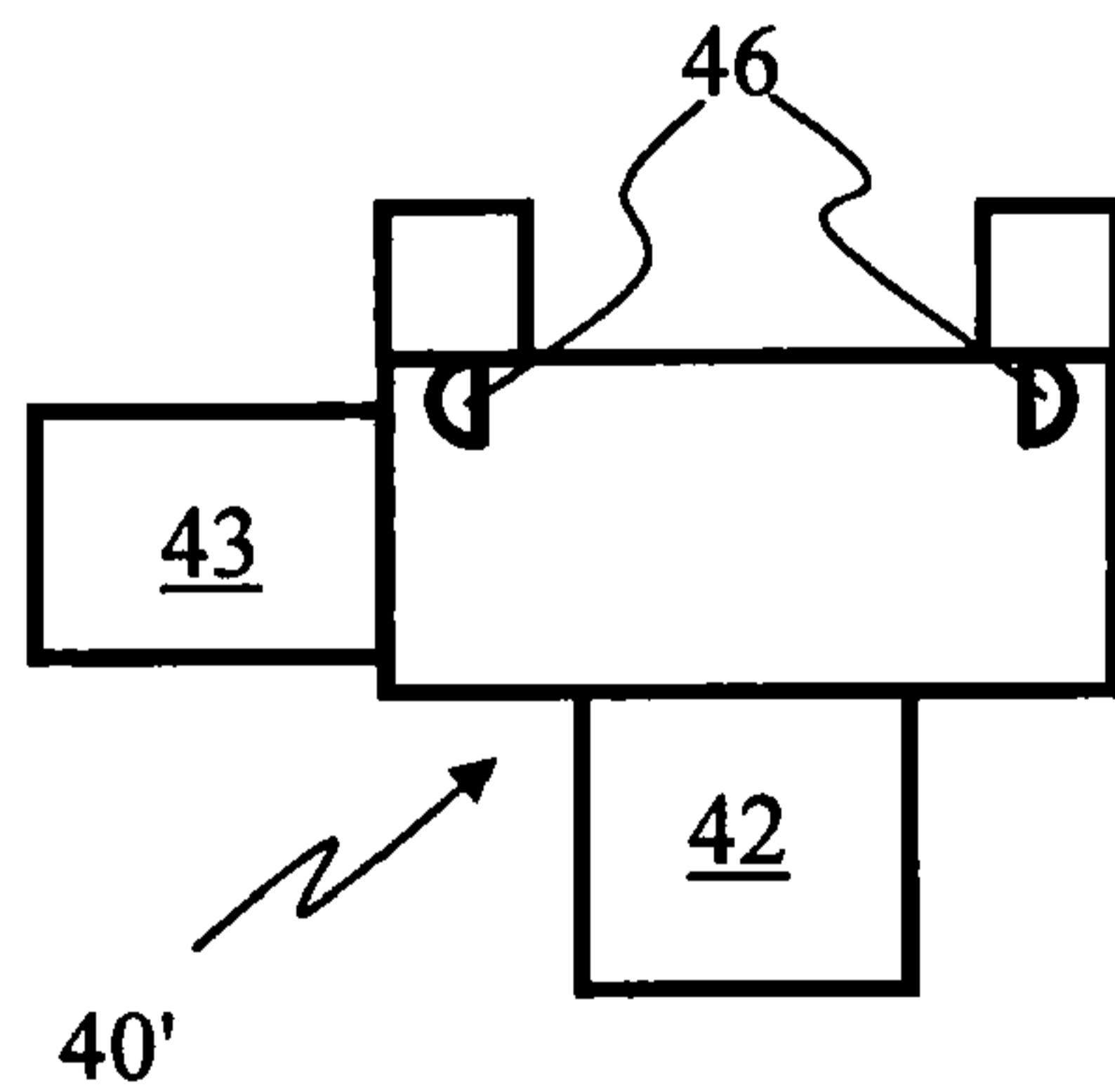

Fig. 4D

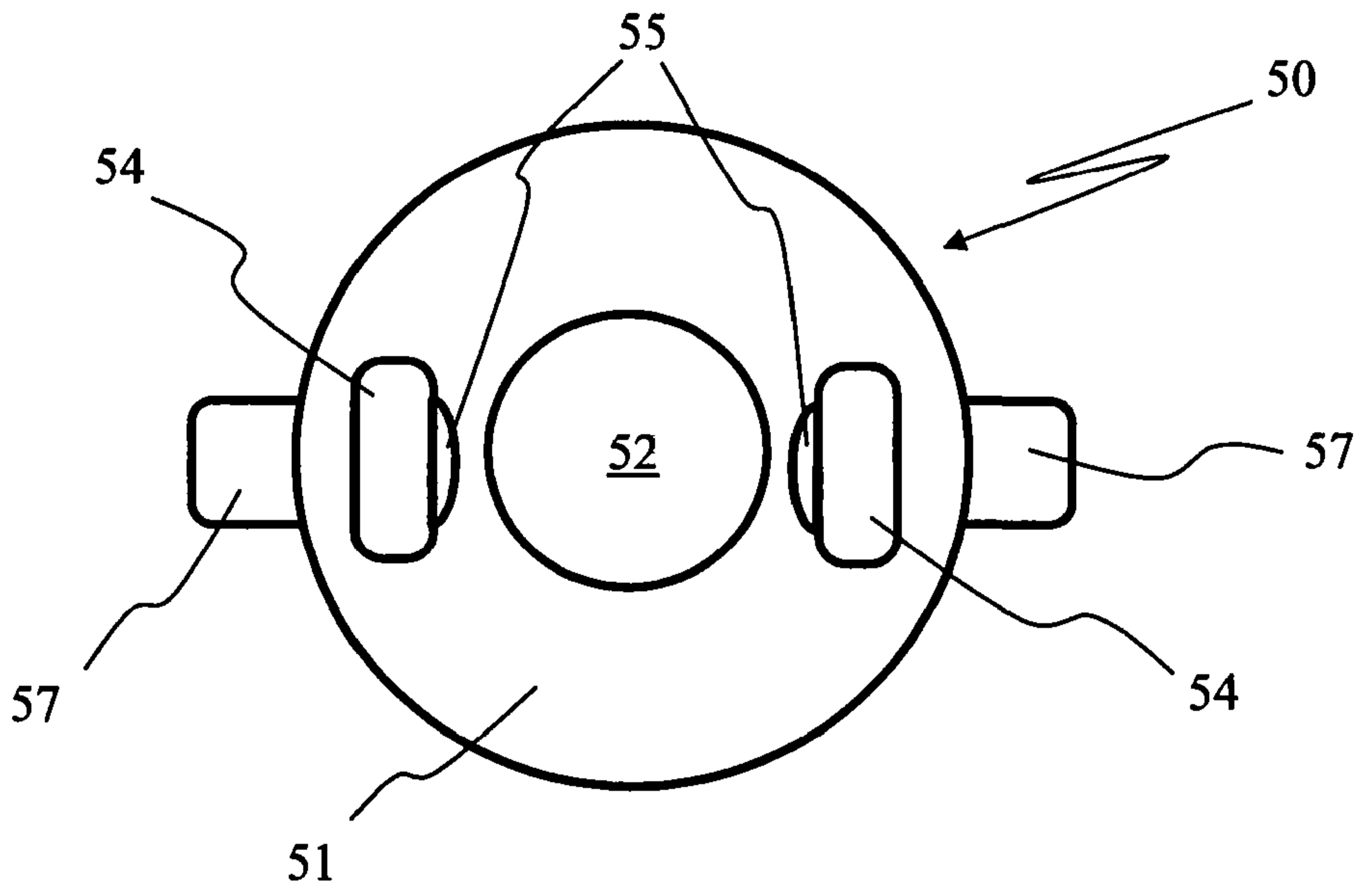

Fig. 5A

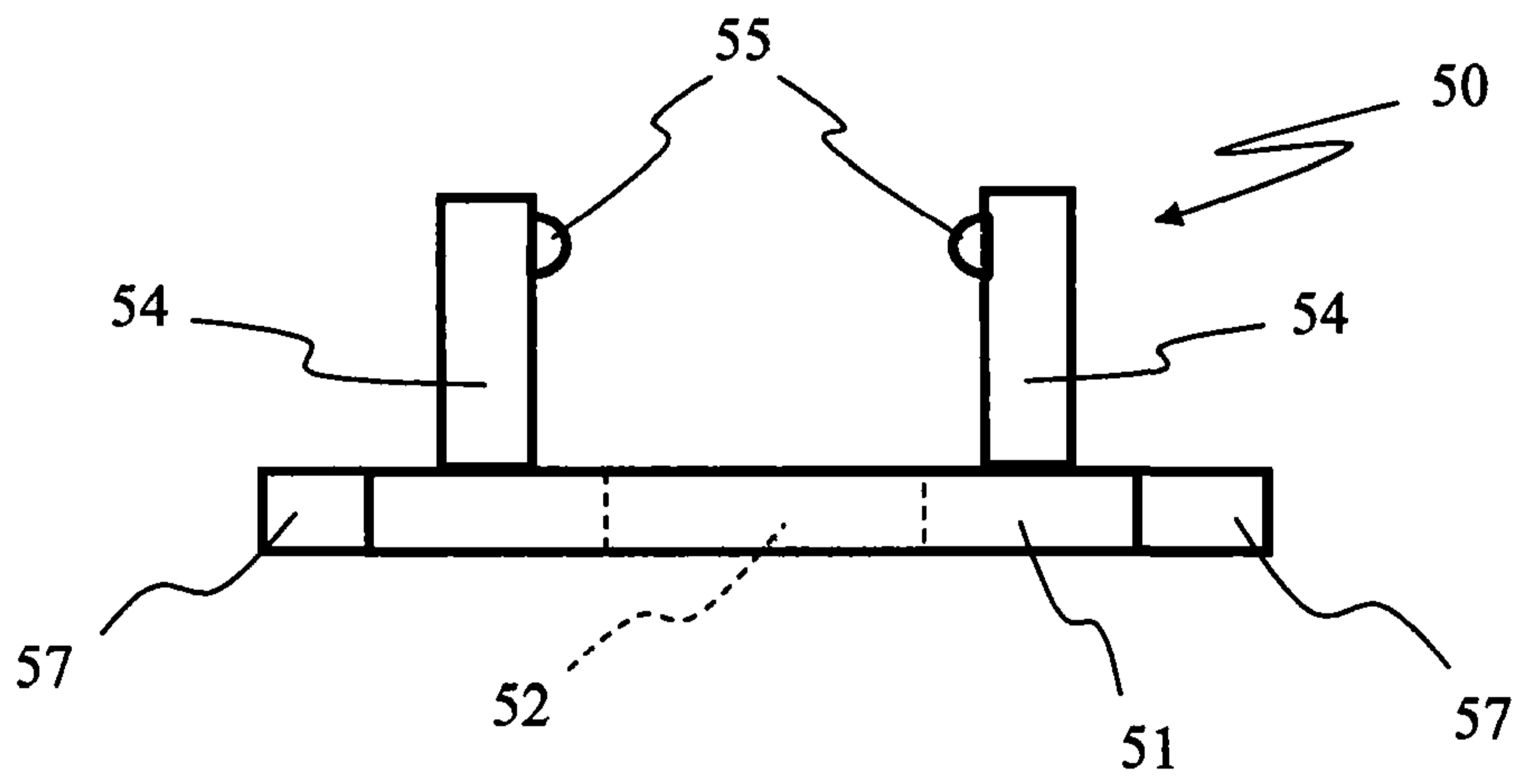

Fig. 5B

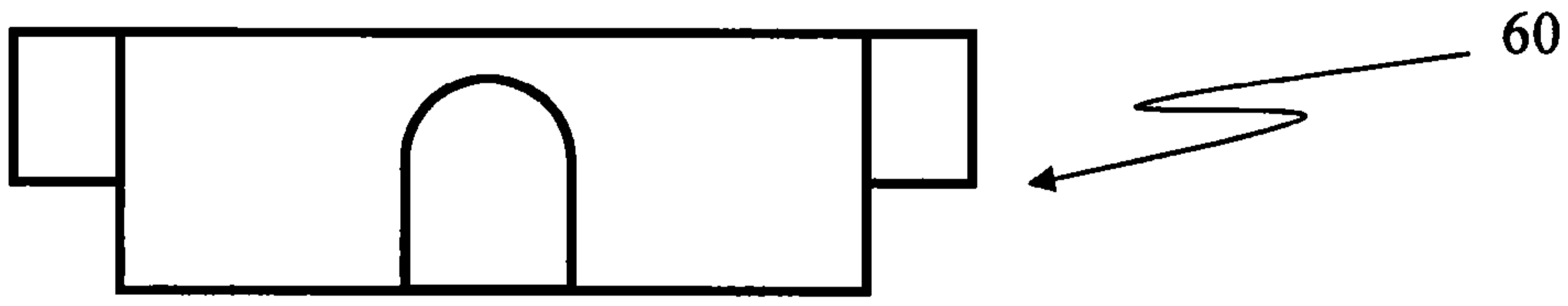

Fig. 6A

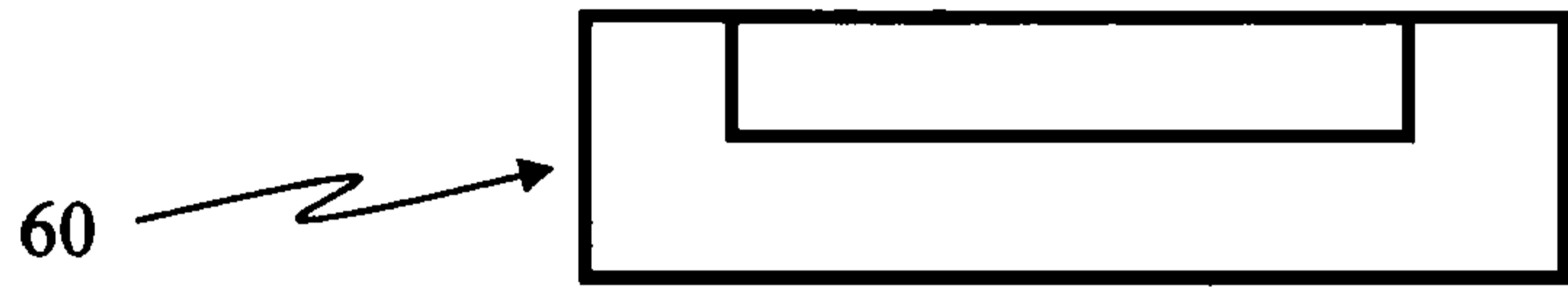

Fig. 6B

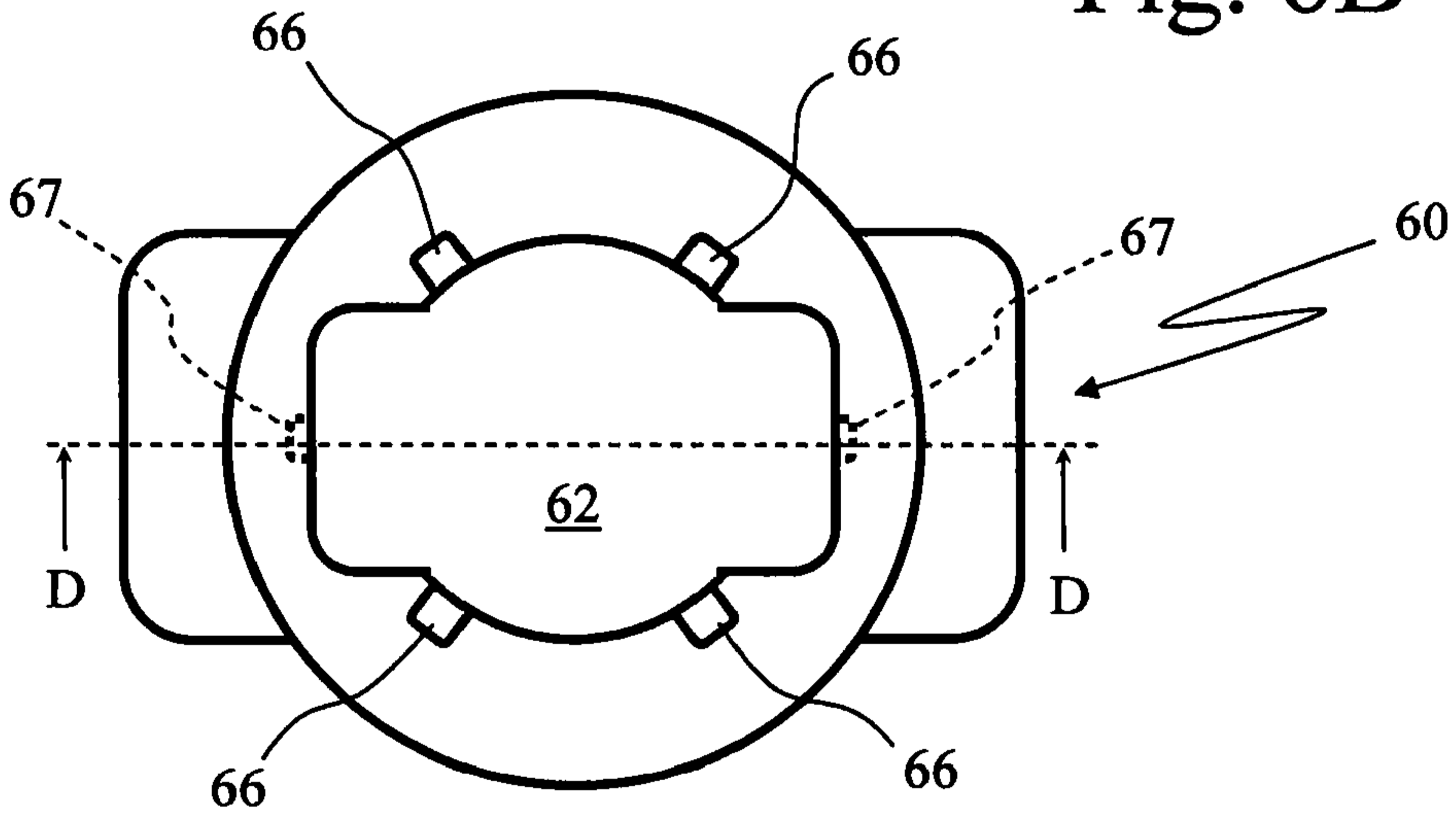

Fig. 6C

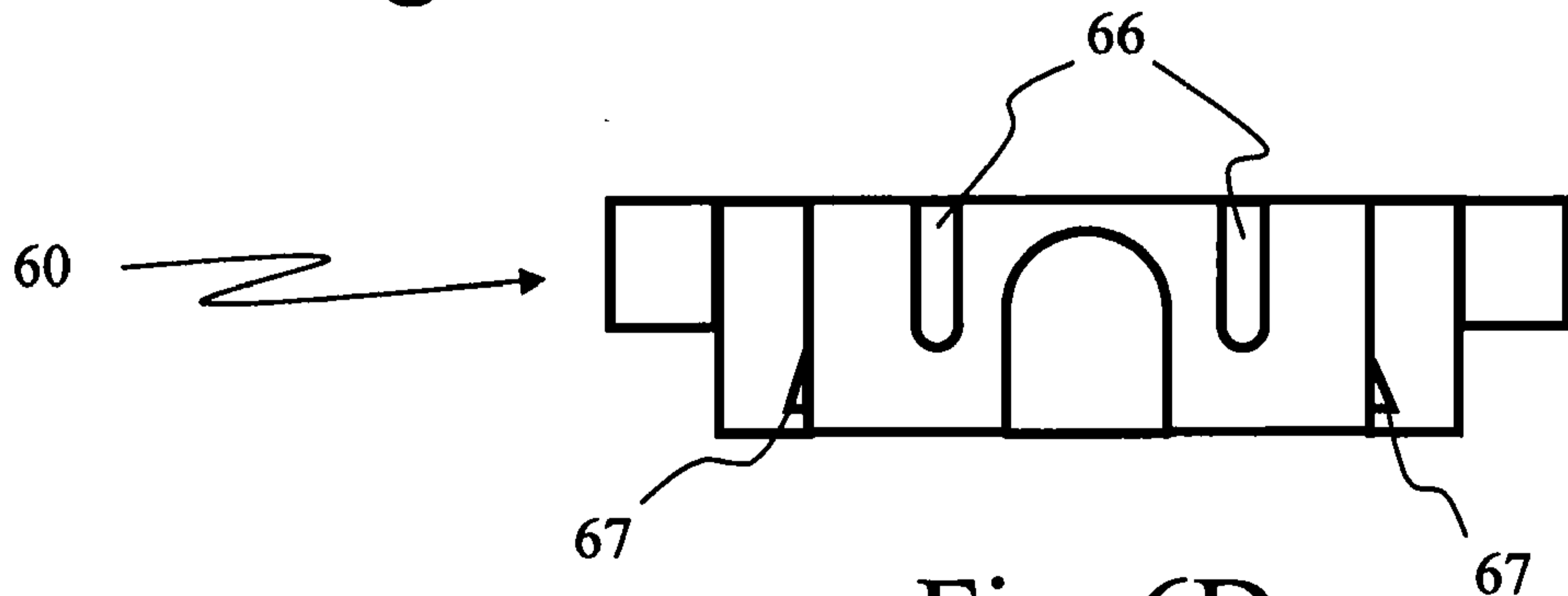

Fig. 6D

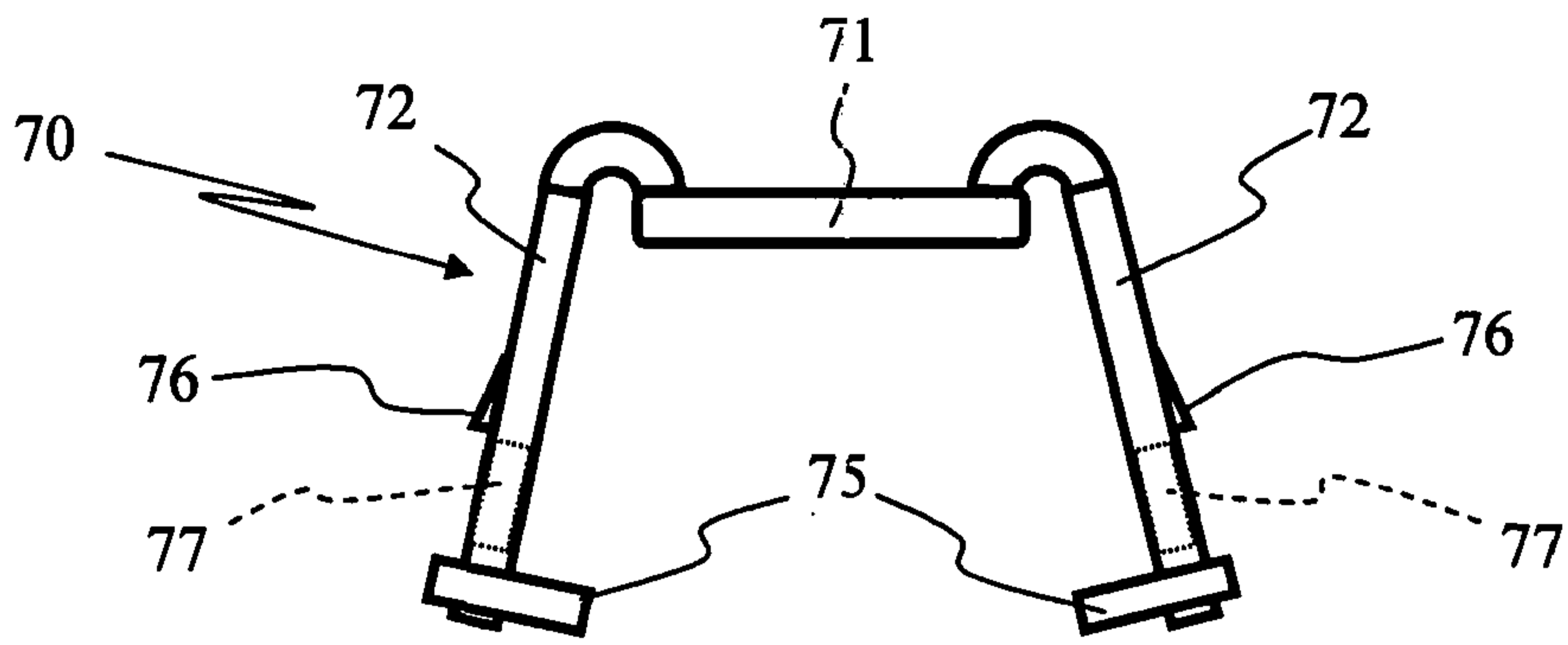

Fig. 7A

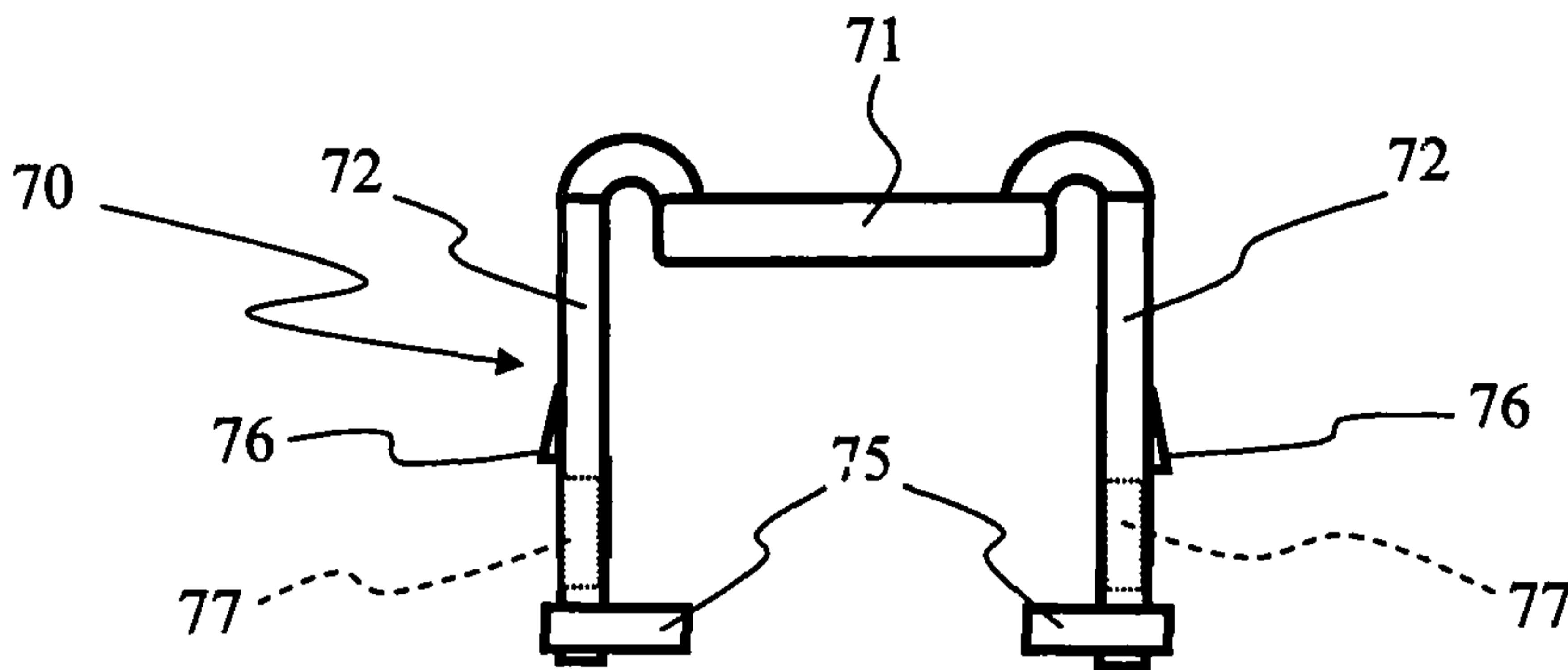

Fig. 7B

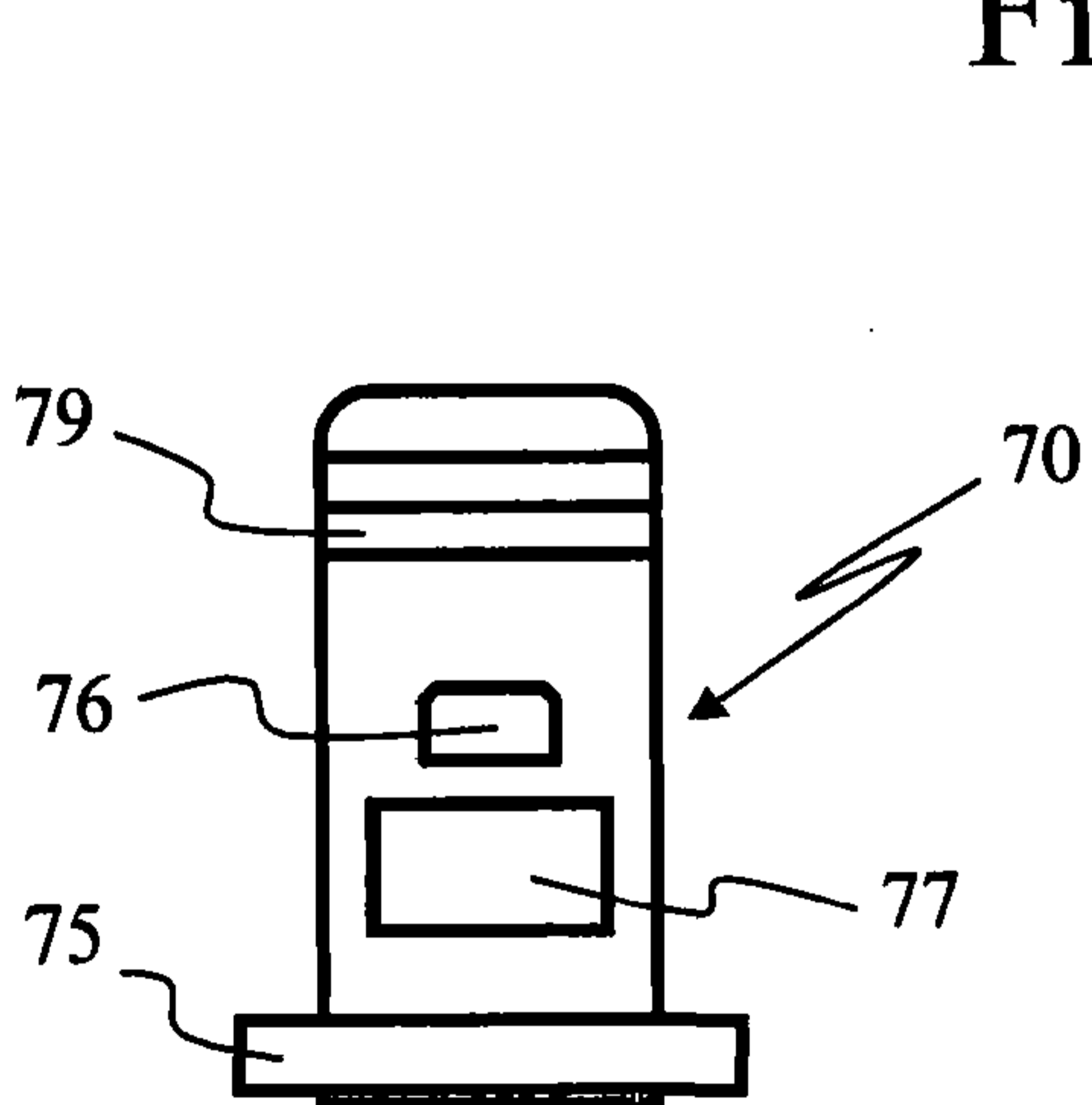

Fig. 7C

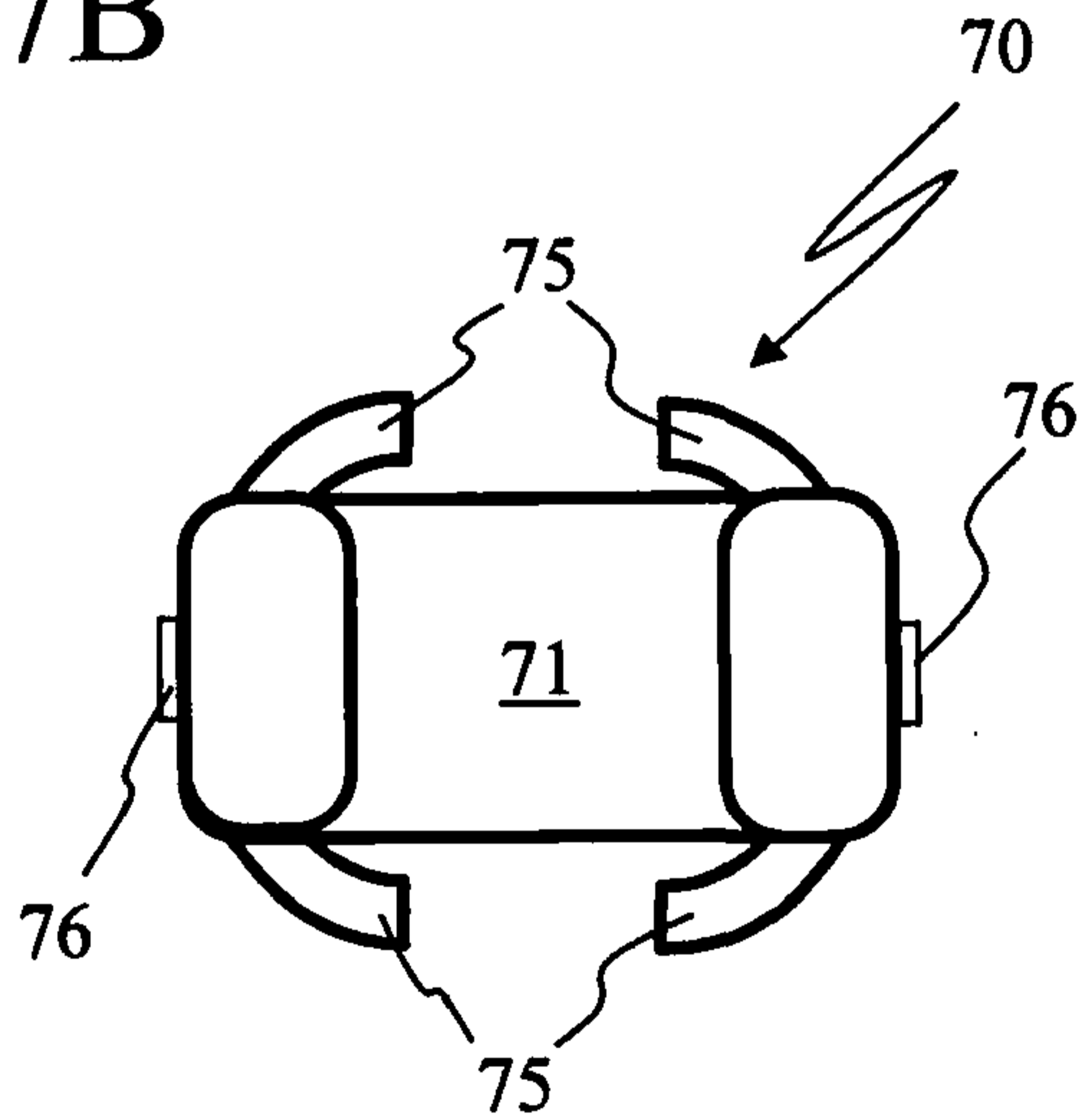

Fig. 7D

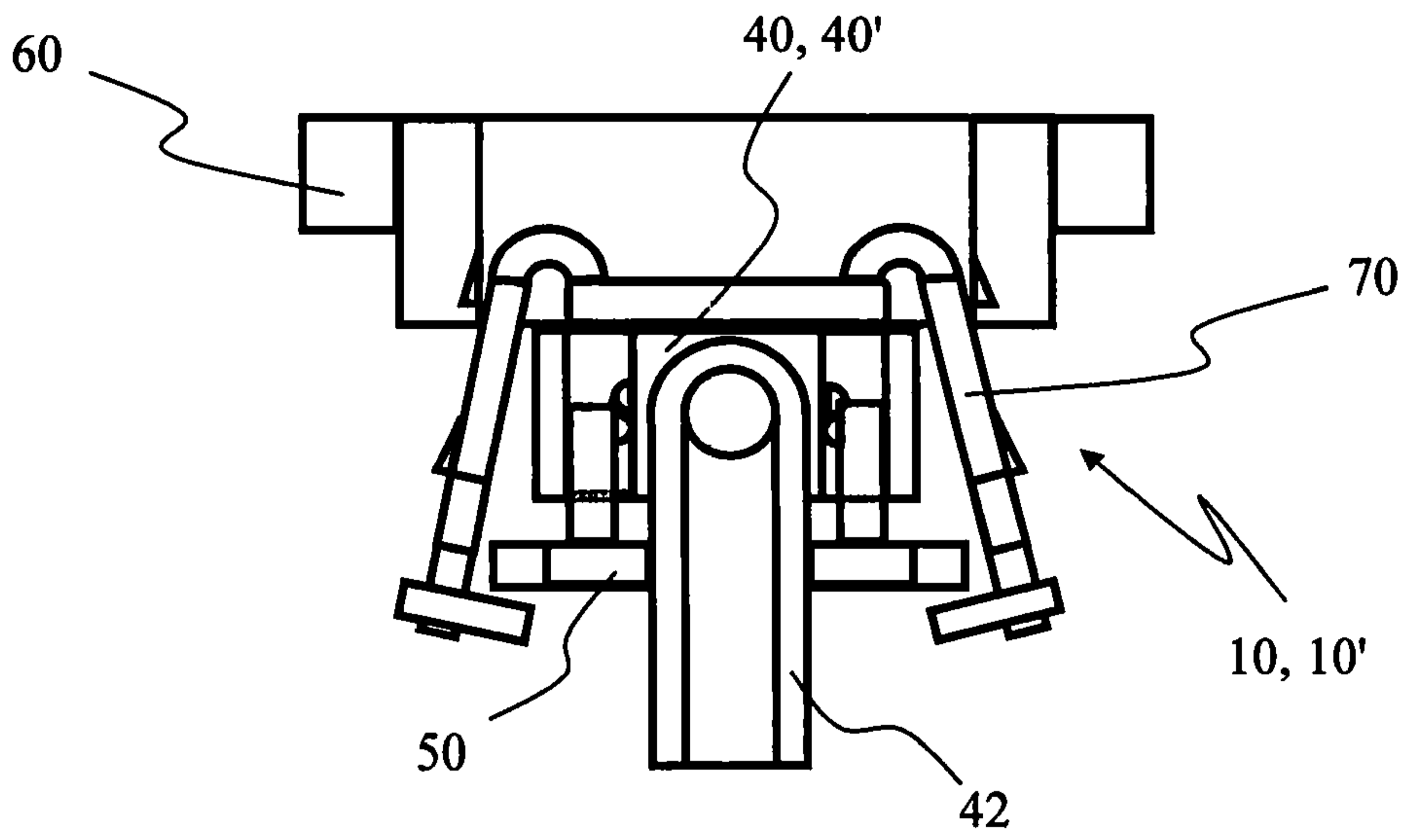

Fig. 8A

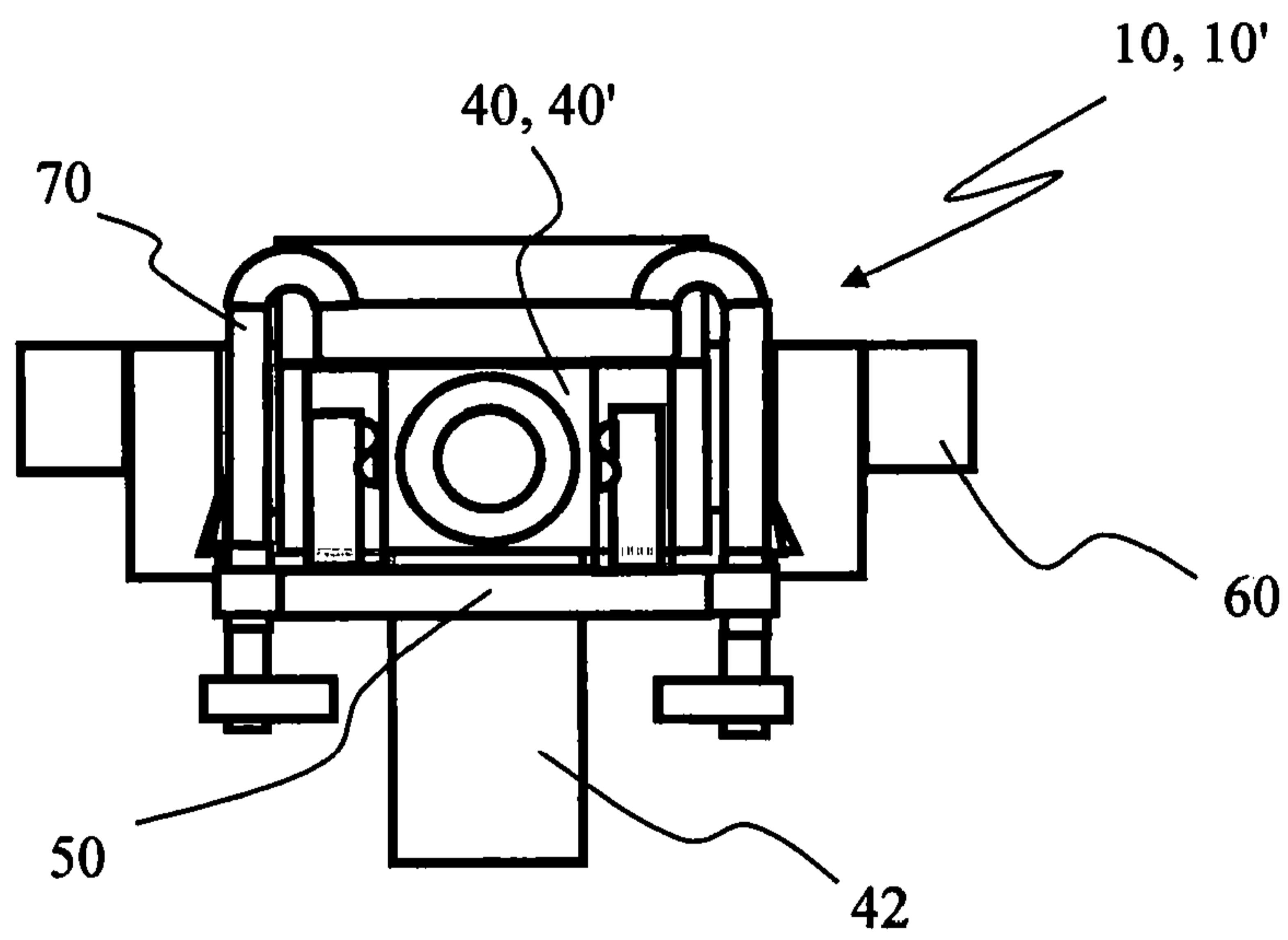

Fig. 8B

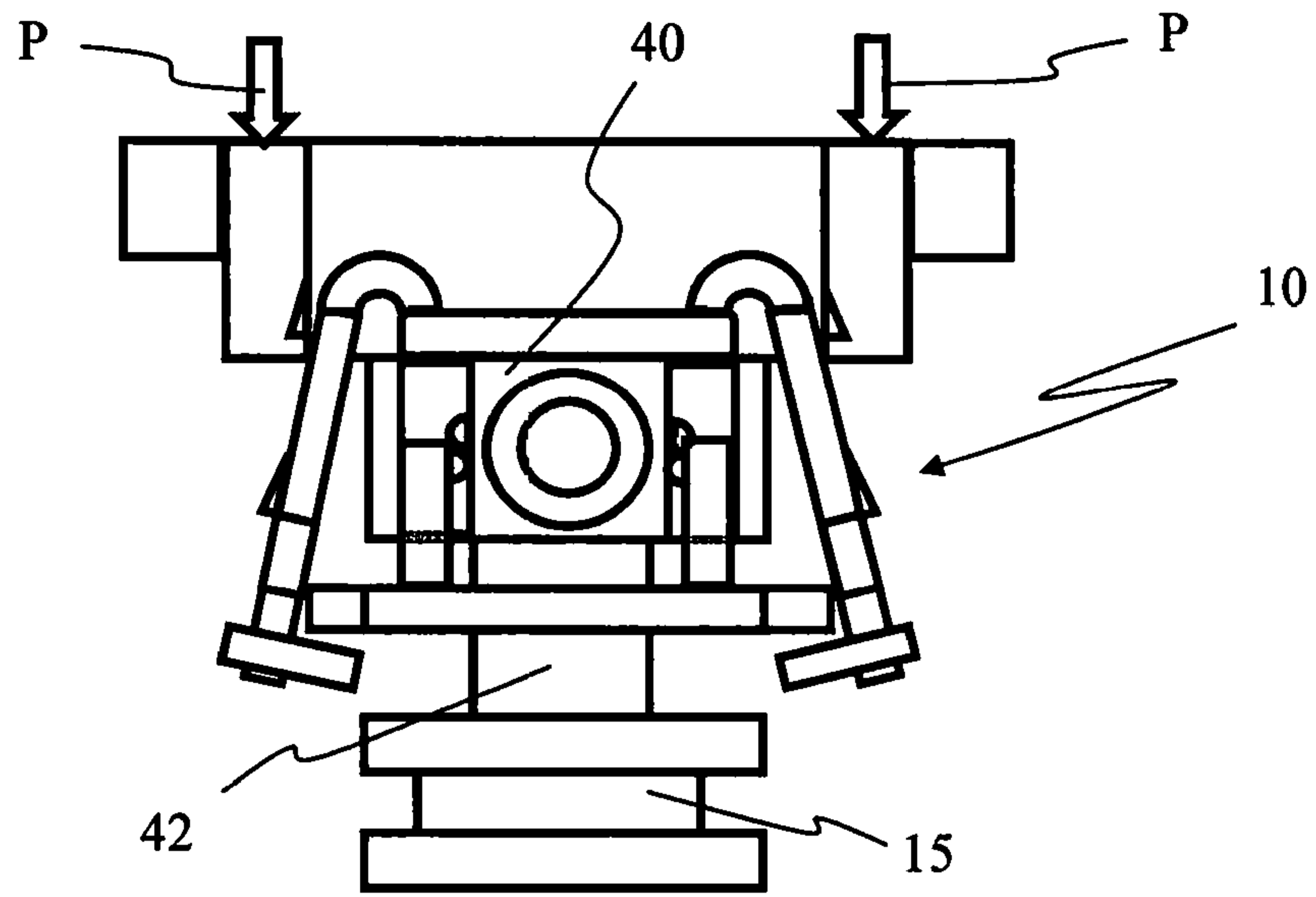

Fig. 9A

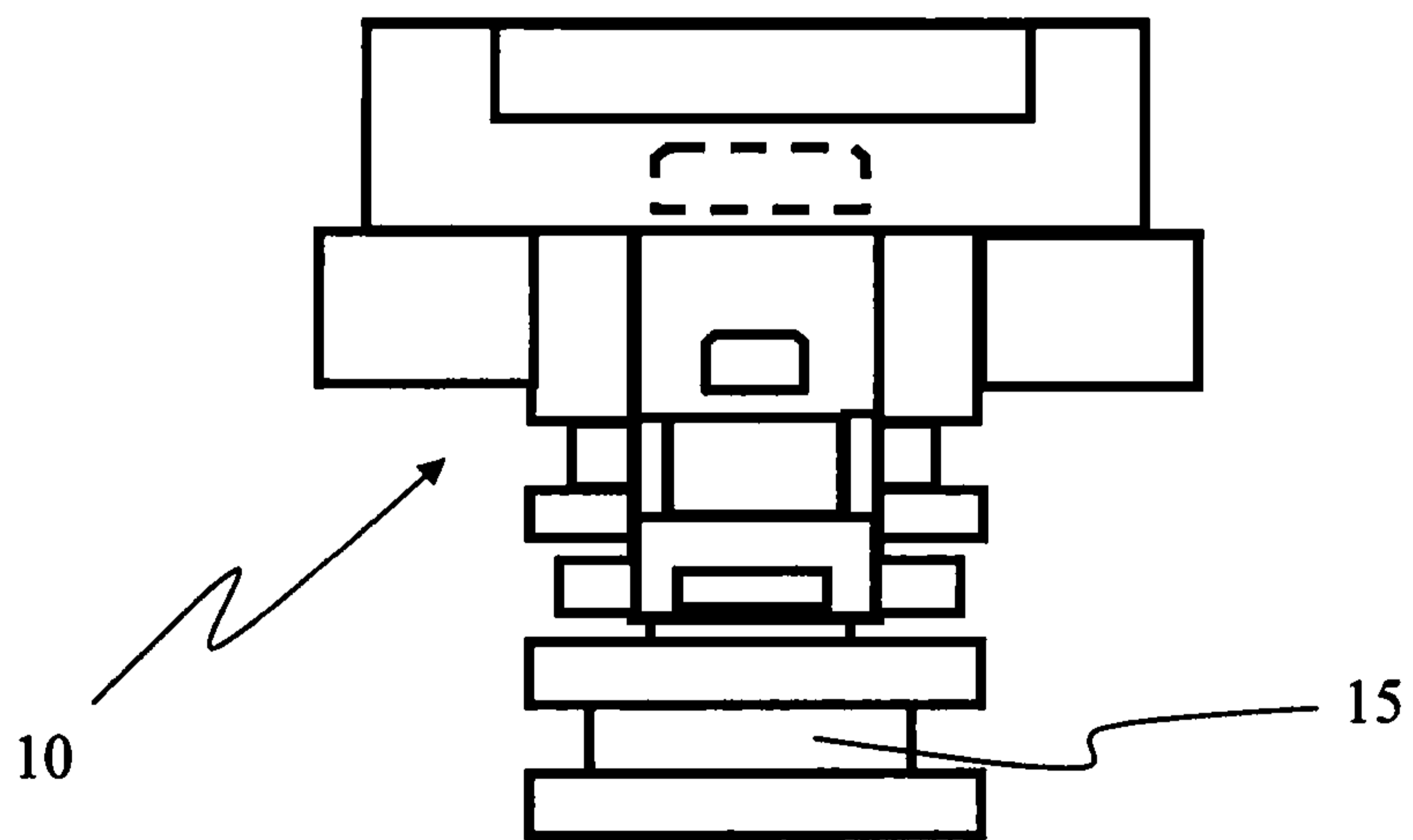

Fig. 9B

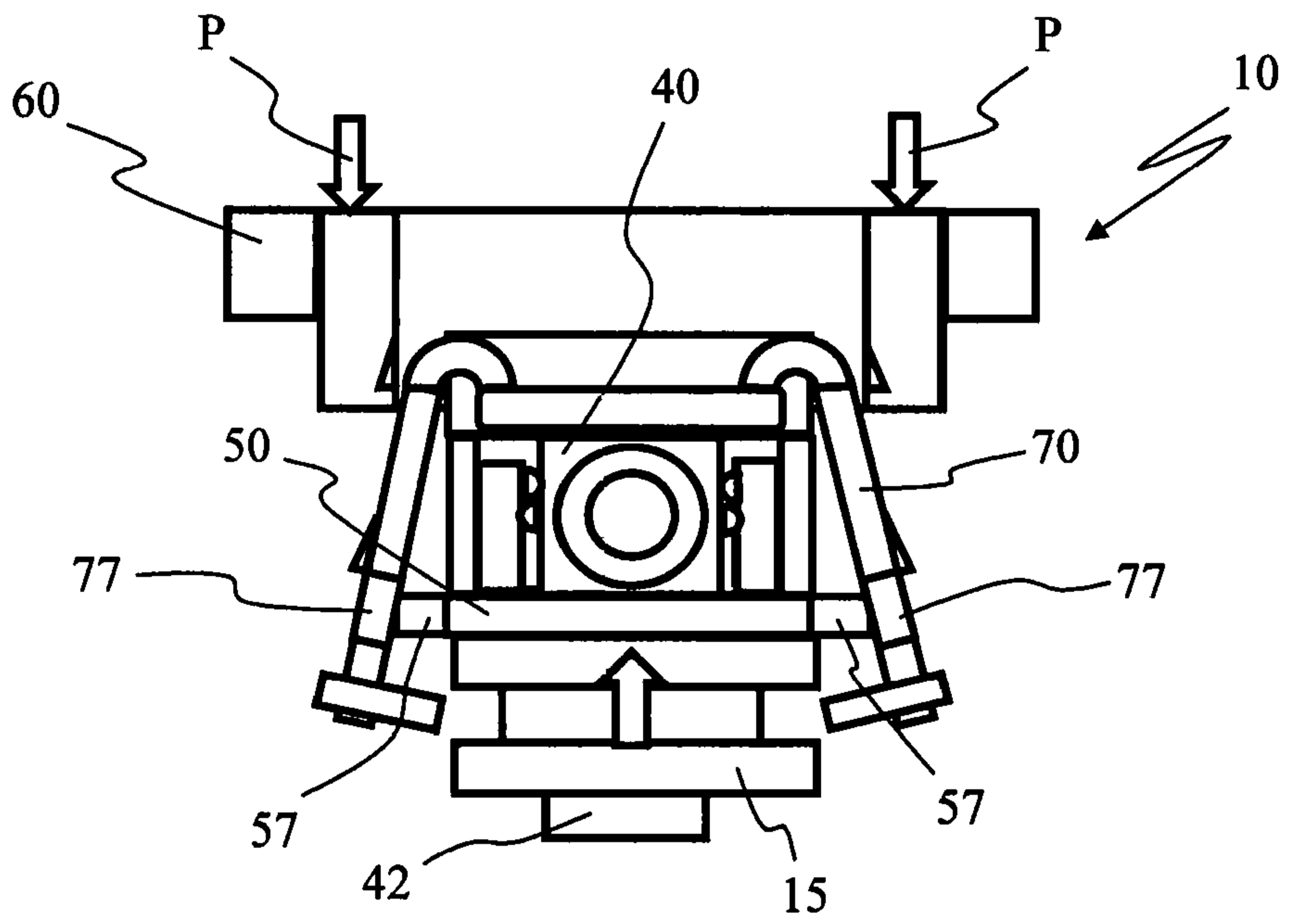

Fig. 10A

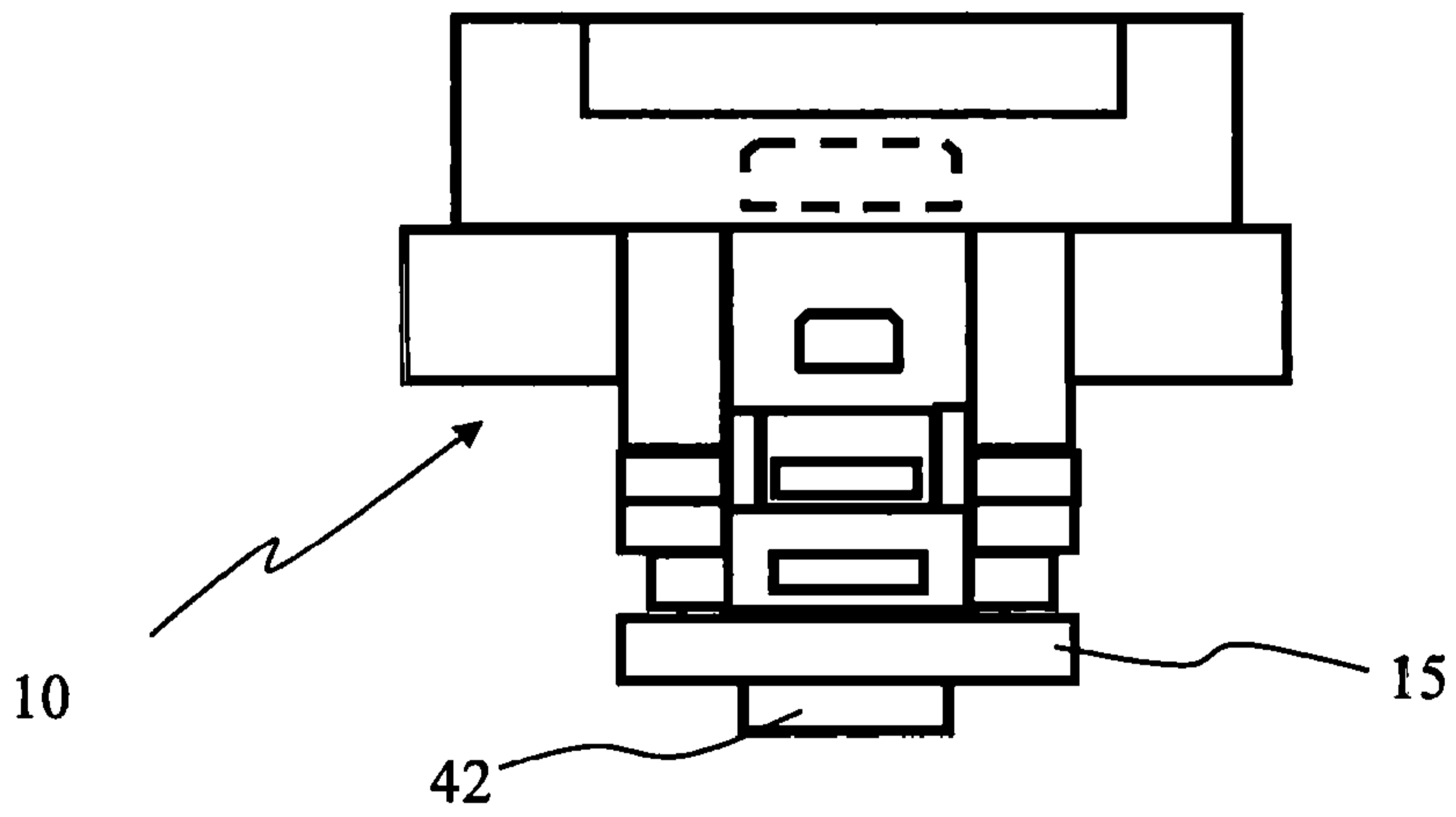

Fig. 10B

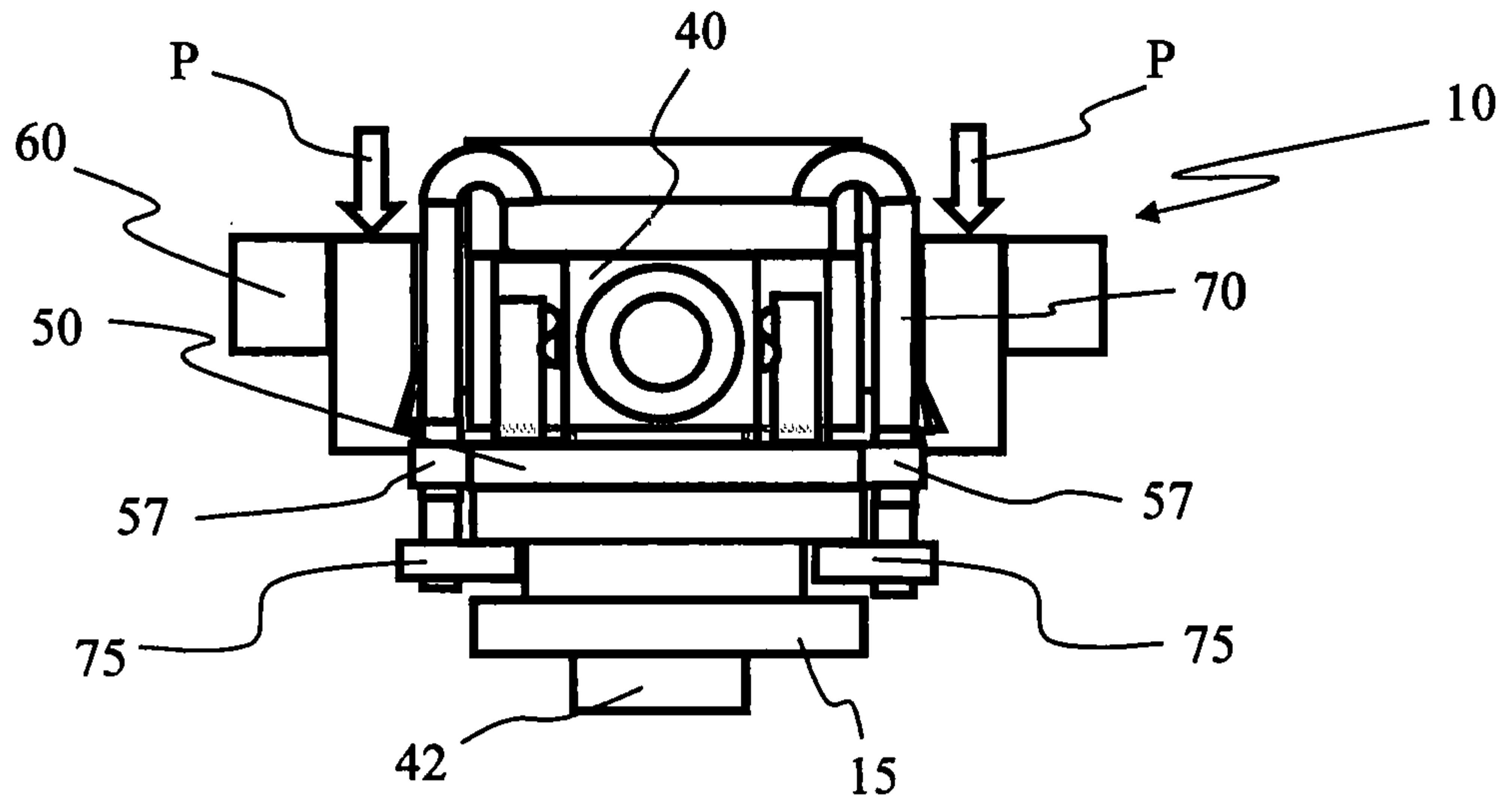

Fig. 11A

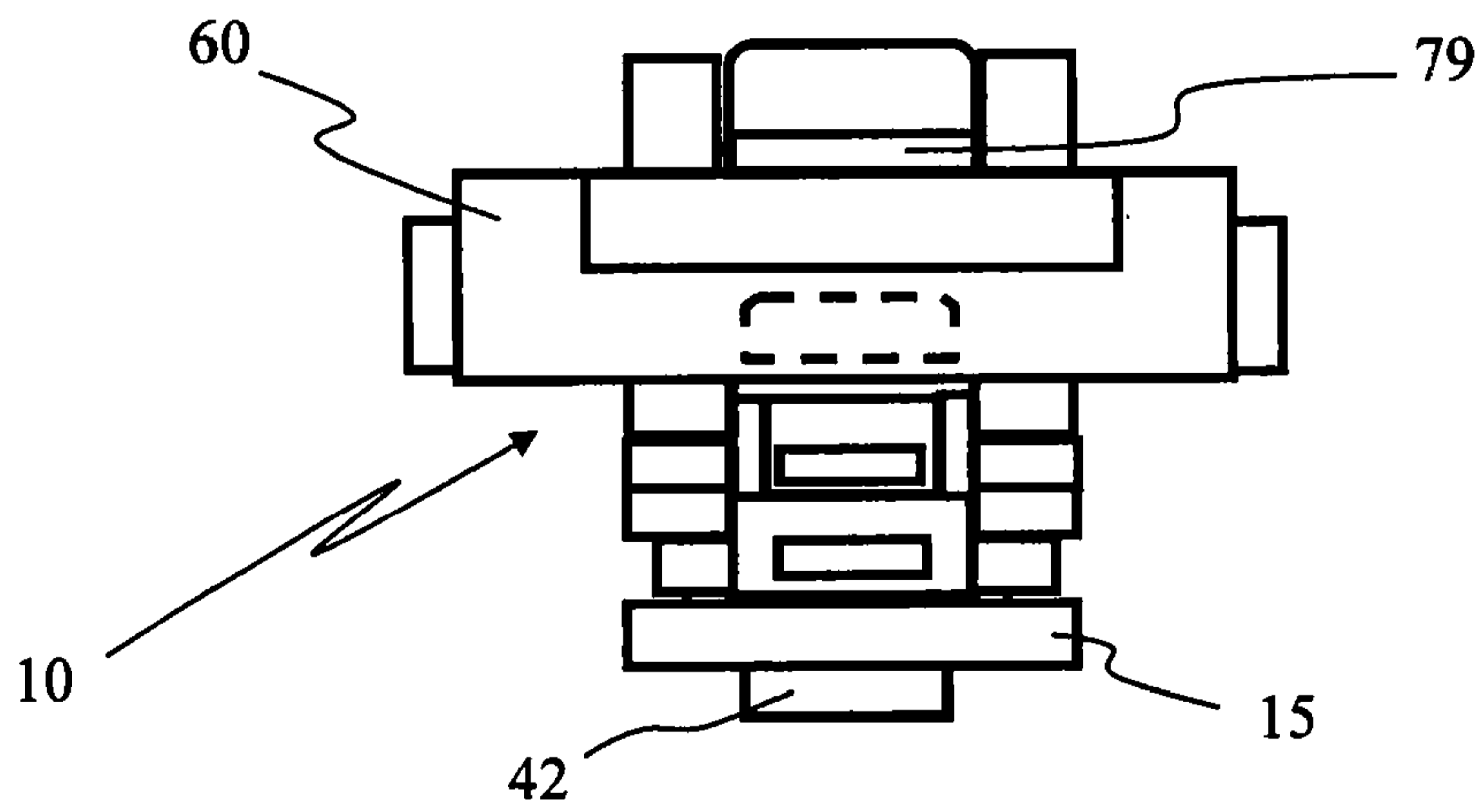

Fig. 11B

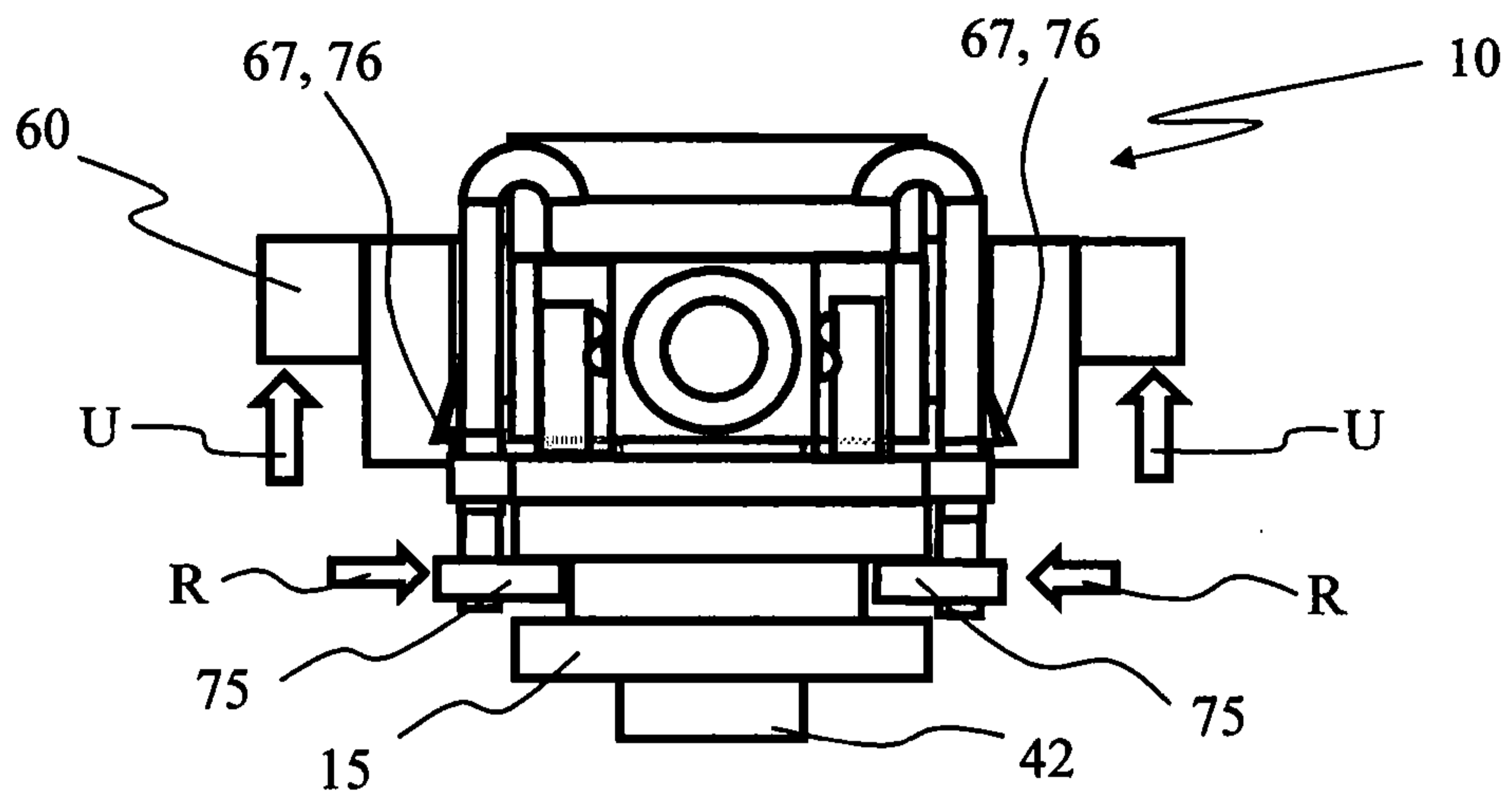

Fig. 12A

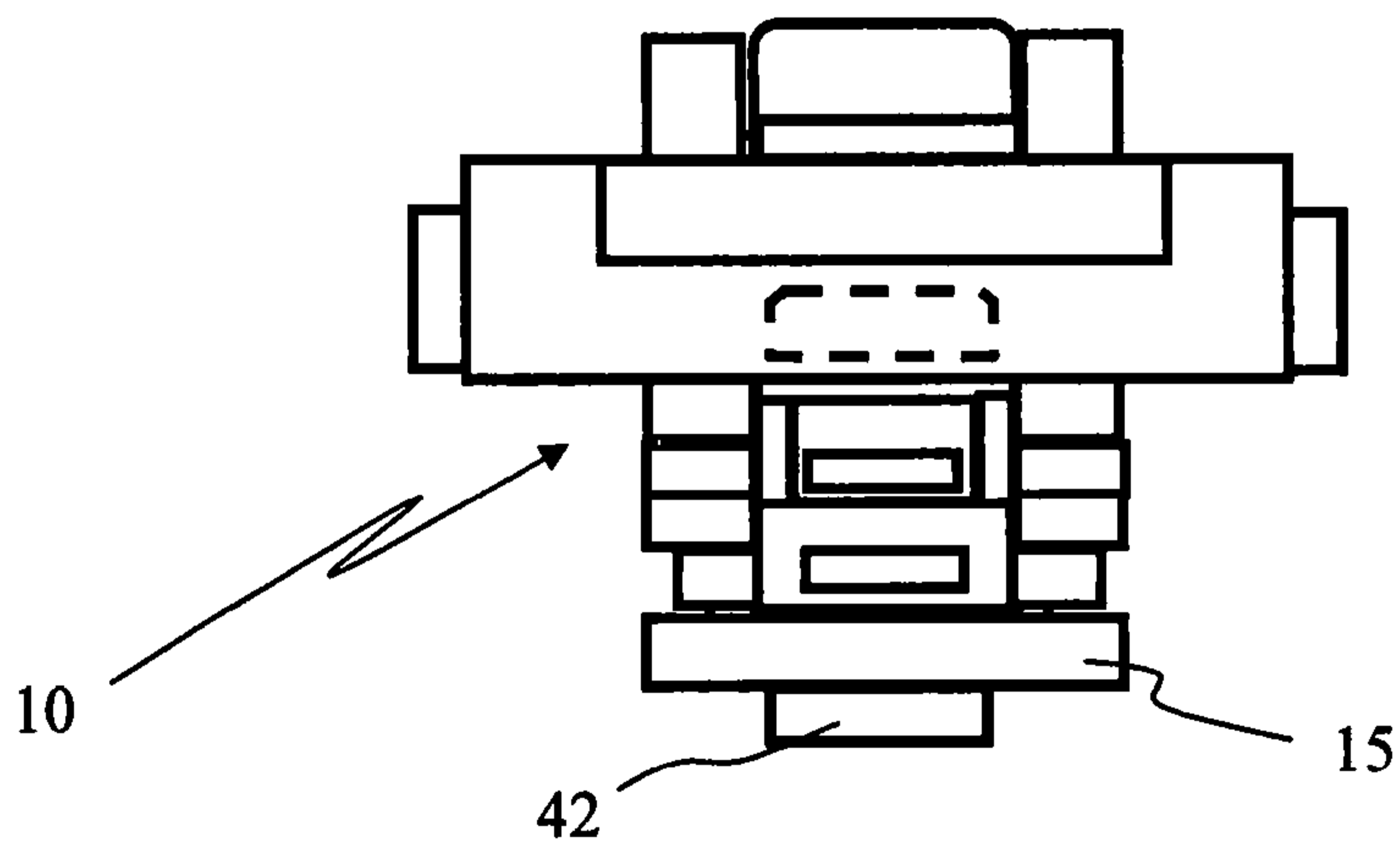

Fig. 12B

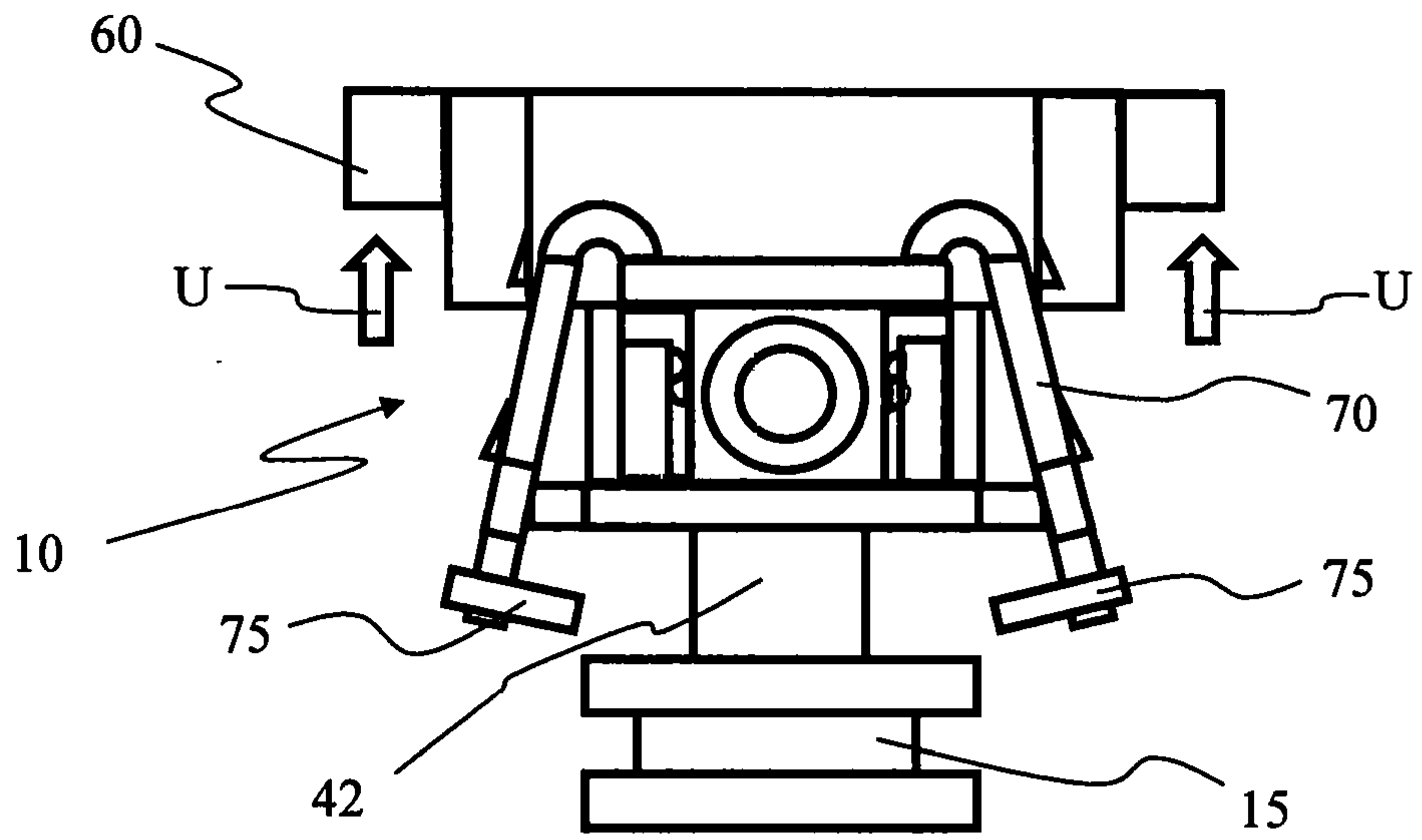

Fig. 13A

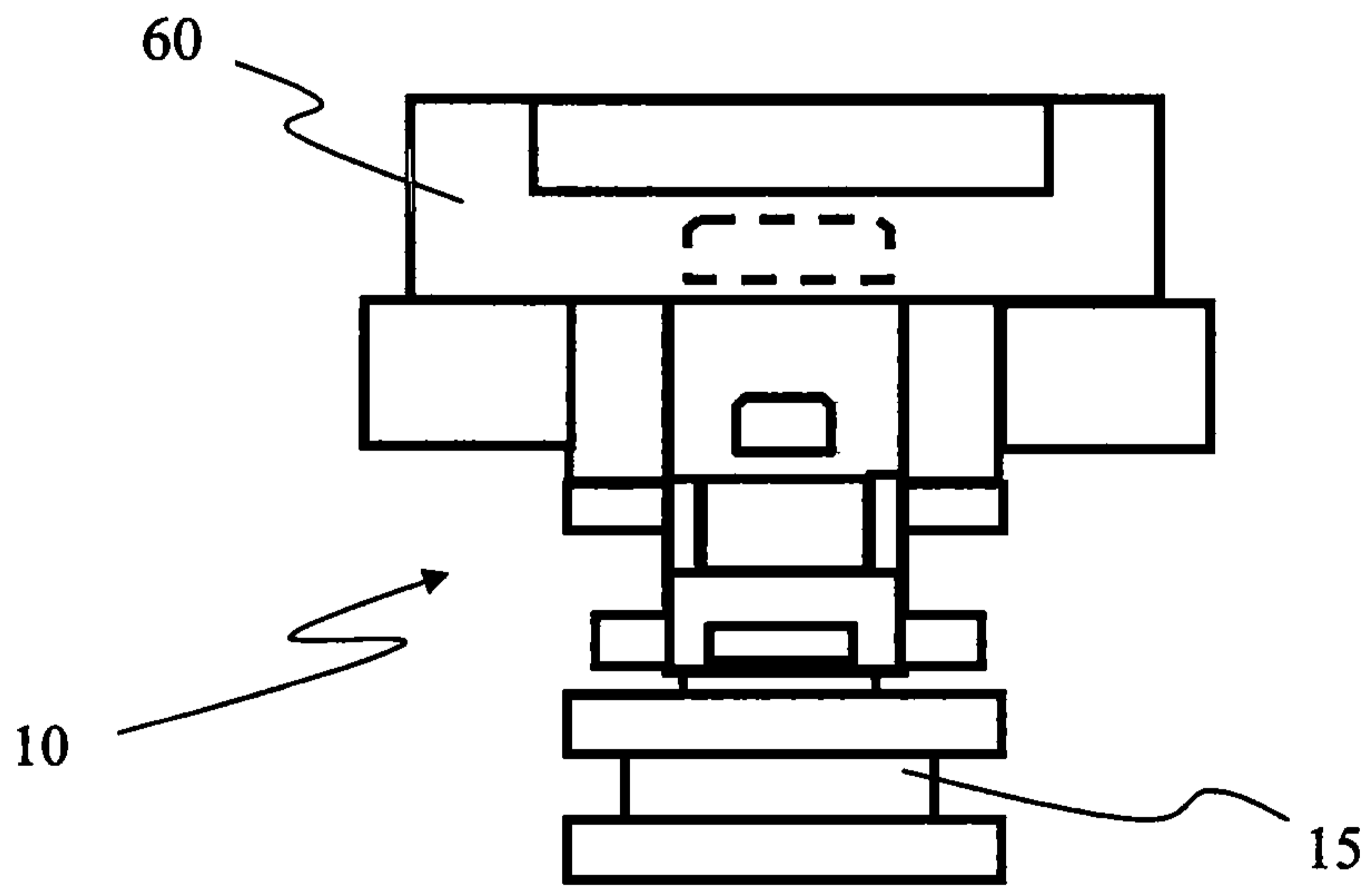

Fig. 13B

5

QUICK FIT CONNECTOR

10 TECHNICAL FIELD

The technical field relates to a connector for low pressure hydraulic circuits and, in particular, a quick fit connector for connecting the injector backflow port to a fuel return line.

BACKGROUND

15 Internal combustion engines are provided with injectors, as for example electro-actuated solenoid injectors that guarantee a high number of pulses at high fuel pressure thanks to a combination of electrical and hydraulic actuation. These kind of injectors are basically made by a high pressure hydraulic valve and a low pressure electro-actuated valve to change hydraulic condition of the first one. Therefore such injectors requires a
20 low pressure circuit to discharge the fuel used for the valves actuation in a fuel return line in order to collect backflow fuel coming out from injectors.

Different solutions have been proposed in the prior art to connect the backflow port of the injectors to the low pressure return line. For example, banjo fittings (also known as banjo bolts or banjo screws) are largely used in the automotive field for providing pipe
25 connections in high pressure circuits. This is a cost and time expensive solution and

requires suitable tools to fix the fitting on the devices connected to the pipe system.

A more simple and cheaper solution envisages a straight connector to be introduced in the backflow port of an injector and a retaining metal clip for latching the connector to the injector. However, this solution does not guarantee error proofing during assembly
5 and service operations.

It is thus an object of an embodiment of the present invention to provide a connector that can be easily and rapidly installed in an internal combustion engine to connect the backflow port of the injectors of an internal combustion engine to the low pressure fuel return line.

10 It is another object of an embodiment of the present invention to provide a connector that can reduce the risk of an improper mounting connection between the injector and the fuel return line.

It is another object of an embodiment of the present invention to provide a connector that can be firmly mounted on an injector in order to prevent accidental disconnection
15 and undesired fuel leakages.

It is another object of an embodiment of the present invention to provide a connector that can be also easily and rapidly removed from the injector to simplify service and maintenance operations.

SUMMARY

20 These and other objects are achieved by a quick fit connector according to claim 1, and by a method for mounting a quick fit connector according to claim 13. Preferred features/aspects are presented in the dependent claims.

According to an embodiment, a quick fit connector for the return line of fuel injectors in an internal combustion engine, comprises:

25 - a T- or L-shaped connector body having at least one connection branch insertable

in a fuel return port of an injector;

- a lower plate;
- an upper plate;
- a spring clip,

5 wherein the upper plate is slidably mounted on the spring clip and the connector body, and wherein the upper plate is movable between an unlocked position, in which the spring clip is in unloaded condition and free from any engagement with the injector, and a locked position in which the spring clip is in loaded condition and engages the injector and the lower plate.

10 Once the connection branch of the T- or L-shaped connector body has been introduced into the fuel return port of an injector, the installation of the connector simply requires to push down the upper plate to compress and load the spring clip up to the engagement with the injector.

15 According to an embodiment, the connector body has at least two through passages parallel to the at least one connection branch, and coupling retaining means for the lower plate are provided inside said through passages.

20 The lower plate has at least two arms projecting perpendicularly from the plate to slidably engage the through passages of the connector body and has a central hole in which the at least one connection branch is slidably engaged. Coupling retaining means are advantageously provided at the end of the arms to cooperate with the coupling retaining means provided inside the through passages of the connector body.

25 Moreover, the lower plate has at least two flanges projecting outside from the perimeter of the plate. The flanges have advantageously multiple functions, e.g. to retain in its lower position the lower plate with respect to the connector body and the spring clip before the installation of the connector and to provide a useful mechanism to ensure the

correct latching of the spring clip on the injector.

Indeed, the spring clip has a web-shaped body including at least two wing portions extending from a central portion. Inwardly protruding lips are provided at the end of the wing portions. The wing portions are angled outwardly when the spring clip is in unloaded condition and brought toward one another when the spring clip is in loaded condition. The inwardly protruding lips engage the injector when the spring clip is in loaded condition.

The flanges of the lower plate abut against the wing portions when the spring clip is in unloaded condition and the wing portions of the spring clip include openings where the flanges of the lower plate are received in engagement when the spring clip is in loaded condition.

In other words, as mentioned above, the lower plate is retained in its lower position with its flanges abutting the wing portions of the spring clip and, at the same time, the lower plate at its lower position prevent the spring clip to be compressed if the connection branch of the connector is not completely inserted in the injector port. After inserting the connection branch in the injector port, the lower plate is pushed up at an upper position, in which the flanges of the lower plate engage the openings in the wing portions, thus allowing the spring clip to be freely compressed.

At least one error proofing mark is advantageously provided on the external surface of the wing portions of the spring clip. The error proofing mark is concealed by the upper plate in its unlocked position and becomes visible when the upper plate is in its locked position. In other words, when the spring clip is completely compressed, the upper plate has reached its lower position and the observable mark guarantees the correct installation is

Coupling retaining means are also provided on the external surface of the wing

portions of the spring clip for retaining the upper plate on the same. Indeed, the upper plate includes a central hole engaged on the connector body and on the spring clip, and coupling retaining means are provided inside the central hole to cooperate with the coupling retaining means provided on the external surface of the wing portions of the spring clip. In this way, the upper plate cannot move up once at its lower position, i.e. the locked position.

According to an embodiment, coupling retaining means for the upper plate are also provided on the external surface of the connector body. In turn, the upper plate includes a central hole engaged on the connector body and on the spring clip, and coupling retaining means are provided inside the central hole to cooperate with the coupling retaining means provided on the external surface of the connector body. This allows the upper plate to be retained at its upper position before the installation.

According to the above embodiments, a good error proofing chain is obtained, e.g. by means of the mark which is visible only when the upper plate reaches its lower position; this position can be reached only when the spring clip is completely compressed; spring clip can be compressed only when the lower plate is at its upper position; and the lower plate can reach its upper position only when the connection branch of the connector is completely inserted in the injector port.

Also the removal of the connector can be simply carried out by applying a radial force on both the wing portions of the spring clip in order to free the upper plate from the coupling retaining means of the spring clip and to move the upper plate up to the unlocked position

Moreover, thanks to several coupling retaining means of the above embodiments, the components of the connector are jointly maintained as a single item which is ready to be installed without using tools or the like.

According to another aspect of the disclosure, a method for mounting a quick fit connector to an injector in an internal combustion engine, comprises the steps of:

a) providing a quick fit connector comprising a T- or L-shaped connector body having at least one connection branch, a lower plate, an upper plate and a spring clip, wherein the upper plate is slidably mounted on the spring clip and the connector body;

b) inserting the at least one connection branch of the T- or L-shaped connector body in a fuel return port of an injector;

c) pushing down the upper plate from an unlocked position, in which the spring clip is in unloaded condition and free from any engagement with the injector, up to a locked position in which the spring clip is in loaded condition and engages the injector and the lower plate.

According to an embodiment of the method, the spring clip has a web-shaped body including a central portion extending between at least two wing portions and protruding inwardly lips are provided at the end of said wing portions. The wing portions are angled outwardly and flanges projecting outside from the perimeter of the lower plate abut against the wing portions when the upper plate is in the unlocked position and said spring clip is in unloaded condition. The wing portions of the spring clip also include openings where the flanges of the lower plate are received in engagement when the upper plate is in the locked position and the spring clip is in loaded condition. In this condition, the inwardly protruding lips at the end of the wing portions engage the injector when the upper plate is pushed down up to the locked position.

According to an embodiment of the method, the spring clip has a web-shaped body including a central portion extending between at least two wing portions. At least one error proofing mark is provided on the external surface of the wing portions of the spring clip. The at least one error proofing mark is concealed by the upper plate in its unlocked

position and becomes visible when the upper plate reaches the locked position.

BRIEF DESCRIPTION OF THE DRAWINGS

Other features advantages and details appear, by way of example only, in the following detailed description of embodiments, with reference to the accompanying drawings, in which:

- Figure 1 shows a possible embodiment of an automotive system comprising an internal combustion engine;
- Figure 2 is a cross-section according to the plane A-A of an internal combustion engine belonging to the automotive system of Figure 1;
- 10 • Figure 3 is an exploded isometric view of some components of an embodiment of a quick fit connector;
- Figure 4A is a top view which shows schematically some features of a T-shaped connector body;
- Figure 4B is a front view of the T-shaped connector body of Figure 4A;
- 15 • Figure 4C is a section view along plane C-C of the T-shaped connector body of Figure 4A;
- Figure 4D is a front view which shows schematically a L-shaped connector body;
- Figure 5A is a top view which shows schematically some features of a lower plate;
- 20 • Figure 5B is a front view of the lower plate of Figure 5A;
- Figure 6A is a front view which shows schematically some features of an upper plate;
- Figure 6B is a side view of the upper plate of Figure 6A;
- Figure 6C is a top view of the upper plate of Figure 6A;
- 25 • Figure 6D is a section view along plane D-D of the upper plate of Figure 6C;

- Figure 7A is a front view which shows schematically some features of a spring clip in unloaded condition;
- Figure 7B is a front view which shows schematically the spring clip of Figure 7A in loaded condition;
- 5 • Figure 7C is a side view of the spring clip of Figure 7B;
- Figure 7D is a top view of the spring clip of Figure 7B;
- Figures 8A and 8B show schematically an embodiment of a quick fit connector before and after the installation, respectively;
- Figures 9A and 9B show schematically a starting phase of the installation of an
10 embodiment of a quick fit connector to the fuel return port of an injector;
- Figures 10A and 10B show schematically an intermediate phase of the installation of an embodiment of a quick fit connector to an injector;
- Figures 11A and 11B show schematically a final phase of the installation of an embodiment of a quick fit connector to an injector;
- 15 • Figures 12A and 12B show schematically a starting phase of the removal of an embodiment of a quick fit connector from the fuel return port of an injector; and
- Figures 13A and 13B show schematically a final phase of the removal of an embodiment of a quick fit connector from the fuel return port of an injector.

DETAILED DESCRIPTION

20 Exemplary embodiments will now be described with reference to the enclosed drawings without intent to limit application and uses.

 Some embodiments may include an automotive system 100, as shown in Figures 1 and 2, that includes an internal combustion engine (ICE) 110 having an engine block 120 defining at least one cylinder 125 having a piston 140 coupled to rotate a crankshaft 145.
25 A cylinder head 130 cooperates with the piston 140 to define a combustion chamber 150.

A fuel and air mixture (not shown) is disposed in the combustion chamber 150 and ignited, resulting in hot expanding exhaust gasses causing reciprocal movement of the piston 140. The fuel is provided by at least one fuel injector 160 and the air through at least one intake port 210. The fuel is provided at high pressure to the fuel injector 160
5 from a fuel rail 170 in fluid communication with a high pressure fuel pump 180 that increase the pressure of the fuel received from a fuel source 190.

Also a low pressure fuel return line 17 connects the injectors 160 to the fuel source 190 through T-shaped connectors 10 and one L-shaped connector 10'.

Each of the cylinders 125 has at least two valves 215, actuated by the camshaft 135
10 rotating in time with the crankshaft 145. The valves 215 selectively allow air into the combustion chamber 150 from the port 210 and alternately allow exhaust gases to exit through a port 220. In some examples, a cam phaser 155 may selectively vary the timing between the camshaft 135 and the crankshaft 145.

The air may be distributed to the air intake port(s) 210 through an intake manifold
15 200. An air intake duct 205 may provide air from the ambient environment to the intake manifold 200. In other embodiments, a throttle body 330 may be provided to regulate the flow of air into the manifold 200. In still other embodiments, a forced air system such as a turbocharger 230, having a compressor 240 rotationally coupled to a turbine 250, may be provided. Rotation of the compressor 240 increases the pressure and temperature of the
20 air in the duct 205 and manifold 200. An intercooler 260 disposed in the duct 205 may reduce the temperature of the air. The turbine 250 rotates by receiving exhaust gases from an exhaust manifold 225 that directs exhaust gases from the exhaust ports 220 and through a series of vanes prior to expansion through the turbine 250. The exhaust gases exit the turbine 250 and are directed into an exhaust system 270. This example shows a
25 variable geometry turbine (VGT) with a VGT actuator 290 arranged to move the vanes to

alter the flow of the exhaust gases through the turbine 250. In other embodiments, the turbocharger 230 may be fixed geometry and/or include a waste gate.

The exhaust system 270 may include an exhaust pipe 275 having one or more exhaust aftertreatment devices 280. The aftertreatment devices may be any device
5 configured to change the composition of the exhaust gases. Some examples of aftertreatment devices 280 include, but are not limited to, catalytic converters (two and three way), oxidation catalysts, lean NO_x traps, hydrocarbon adsorbers, selective catalytic reduction (SCR) systems, and particulate filters. Other embodiments may include an exhaust gas recirculation (EGR) system 300 coupled between the exhaust
10 manifold 225 and the intake manifold 200. The EGR system 300 may include an EGR cooler 310 to reduce the temperature of the exhaust gases in the EGR system 300. An EGR valve 320 regulates a flow of exhaust gases in the EGR system 300.

The automotive system 100 may further include an electronic control unit (ECU) 450 in communication with one or more sensors and/or devices associated with the ICE 110.
15 The ECU 450 may receive input signals from various sensors configured to generate the signals in proportion to various physical parameters associated with the ICE 110. The sensors include, but are not limited to, a mass airflow and temperature sensor 340, a manifold pressure and temperature sensor 350, a combustion pressure sensor 360, coolant and oil temperature and level sensors 380, a fuel rail pressure sensor 400, a cam
20 position sensor 410, a crank position sensor 420, exhaust pressure and temperature sensors 430, an EGR temperature sensor 440, and an accelerator pedal position sensor 445. Furthermore, the ECU 450 may generate output signals to various control devices that are arranged to control the operation of the ICE 110, including, but not limited to, the fuel injectors 160, the throttle body 330, the EGR Valve 320, the VGT actuator 290, and
25 the cam phaser 155. Note, dashed lines are used to indicate communication between the

ECU 450 and the various sensors and devices, but some are omitted for clarity.

Turning now to the ECU 450, this apparatus may include a digital central processing unit (CPU) in communication with a memory system 460, or data carrier, and an interface bus. The CPU is configured to execute instructions stored as a program in the memory system, and send and receive signals to/from the interface bus. The memory system may include various storage types including optical storage, magnetic storage, solid state storage, and other non-volatile memory. The interface bus may be configured to send, receive, and modulate analog and/or digital signals to/from the various sensors and control devices.

Instead of an ECU 450, the automotive system 100 may have a different type of processor to provide the electronic logic, e.g. an embedded controller, an onboard computer, or any processing module that might be deployed in the vehicle.

As better shown in Figure 3, an embodiment of a T-shaped connector 10 for the return line 17 of fuel injectors 160 in an internal combustion engine 110 comprises a T-shaped connector body 40 having a connection branch 42 insertable in a fuel return port 15 (see e.g. Figs. 9A and 9B) of an injector 160, a lower plate 50, an upper plate 60 and a spring clip 70.

The connector body 40 shown in Figures 4A-4C is also provided with two line branches 43, perpendicularly arranged with respect to the connection branch 42 and in fluid communication with the same and between them for the connection of the T-shaped connector 10 to the fuel return line 17. It has to be noted that the two line branches 43 of the connector body 40 can be arranged coaxially (as for example shown in figures 4A – 4C), or angled one with respect to another (i.e. with their axes not coincident). The expression “T-shaped connector” used herein, can be applied to both configurations, i.e. coaxially and angled line branches 43, even if in the shown embodiment and in the

following specific reference will be made to a configuration wherein the line branches 43 are coaxially arranged.

Two through passages 44 parallel to the connection branch 42 are provided in the connector body 40 and coupling retaining means 45 for the lower plate 50 are provided inside the through passages 44. Coupling retaining means 46 for the upper plate 60 are also provided on the external surface of the connector body 40. According to a possible embodiment, coupling retaining means 45, 46 comprise a protruding portion intended to cooperate by an interference fit with another component of the connector. However, according to other possible embodiment, different configuration of the coupling retaining means can be provided.

Figure 4D shows schematically an embodiment of the connector body 40' for a L-shaped connector 10' shown in Figure 1. The connector body 40' is similar to the connector body 40, i.e. it has the same through passages 44 and the same coupling retaining means 45 and 46 provide inside and outside the body; the only difference consists in a single line branch 43, perpendicularly arranged with respect to the connection branch 42 and in fluid communication with the same, for the connection of the L-shaped connector 10' to an end of the fuel return line 17.

As schematically shown in Figures 5A and 5B, an embodiment of the lower plate 50 has a flat portion 51, e.g. of substantially circular shape, with a central hole 52 in which the connection branch 42 of the connector body is slidingly engaged. On diametrically opposite sides of the hole 52 there are provided two arms 54 projecting perpendicularly from the flat portion 51 of the lower plate 50. The arms 54 are slidingly engaged on the through passages 44 of the connector body 40 (or 40') and are provided at their ends with coupling retaining means 55 that cooperate with the coupling retaining means 45 provided inside the through passages 44 of the connector body 40 (or 40'). According to

a possible embodiment, coupling retaining means 55 comprise a protruding portion intended to cooperate by an interference fit with coupling retaining means 45 provided inside the through passages 44 of the connector body 40 (or 40').

5 Two flanges 57 project outside in diametrically opposed positions from the perimeter of the flat portion 51 of the lower plate 50.

10 Figures 6A-6D schematically show an embodiment of an upper plate 60 which includes a central hole 62 engaged on the connector body 40 (or 40') and on the spring clip 70. Coupling retaining means 66 are provided inside the central hole 62 to cooperate with the coupling retaining means 46 provided on the external surface of the connector body 40 (or 40'). Coupling retaining means 67 are also provided inside the central hole 62 to cooperate with corresponding coupling retaining means 76 provided on the external surface of the spring clip 70.

15 An embodiment of a spring clip 70 is schematically shown in Figures 7A-7D. The spring clip 70 has a web-shaped body including at least two wing portions 72 extending from a central portion 71 and inwardly protruding lips 75 at the end of the wing portions 72.

20 Figure 7A shows the spring clip 70 in unloaded condition, i.e. a condition in which the wing portions 72 are angled outwardly, whereas Figure 7B shows the spring clip 70 in loaded condition, i.e. a condition in which the wing portions 72 are brought toward one another. The same loaded condition of the spring clip 70 is that shown in Figure 3.

25 Coupling retaining means 76, here represented as wedge-shaped projections, are provided on the external surface of the wing portions 72 of the spring clip 70 to cooperate with coupling retaining means 67 (e.g. a comprising a seat intended to cooperate with the wedge-shaped projections) provided inside the central hole 62 of the upper plate 60. Even if reference has been made to wedge-shaped projections intended to cooperate

with a correspondent seat, different configurations of the coupling retaining means 76 and 67 can be provided.

The wing portions 72 of the spring clip 70 also include openings 77 where the flanges 57 of the lower plate 50 are received in engagement when the spring clip 70 is in loaded condition.

As shown in Figure 7C, the spring clip 70 also comprises at least one error proofing mark 79, e.g. a colored mark, on the external surface of the wing portions of the spring clip 70. As better explained below, the error proofing mark 79 is concealed by the upper plate 60 when it is in its unlocked position, and becomes visible when the upper plate 60 is in its locked position.

For a better understanding of the mutual combination of the components so far described, Figure 8A shows the connector 10 (or 10') before the installation on an injector. The lower plate 50 is coupled to the connector body 40 by means of their arms inserted in the through passages 44 of the connector body. The flanges 57 of the lower plate 50 abut against the wing portions 72 of the spring clip 70 in unloaded condition, in order to maintain the wing portions 72 in an outwardly angled position. The spring clip 70 is in unloaded condition, i.e. free from any engagement with the injector. The upper plate 60 is slidingly mounted on the spring clip 70 and the connector body 40. In this condition the upper plate is in its unlocked position and is constrained from the extraction by the cooperation of coupling retaining means 46 on the connector body 40 and coupling retaining means 66 provided inside the upper plate.

Starting from the condition shown in Figure 8A, the upper plate 60 can be pushed down up to reach a locked position shown in Figure 8B, i.e. the final position assumed after the installation of the connector 10 (or 10') in which the spring clip 70 is in loaded condition and engages the injector and the flanges 57 of the lower plate 50.

More particularly, as shown in Figures 9A and 9B, the first step of the installation phase of a connector 10 envisages the insertion of the connection branch 42 of the T-shaped connector body 40 in the fuel return port 15 of an injector.

Then, as shown in Figures 10A and 10B, the upper plate 60 is pushed down (arrows P) and the lower plate 50, which abuts against the injector, causes the rising of the lower plate 50. The coupling retaining means 55 provided on the arms 54 go beyond the corresponding coupling retaining means 45 provided inside the through passages 44 and, at the same time, the flanges 57 of the lower plate 50 are brought in correspondence of the openings 77 provided on the wing portions 72.

By further pushing down (arrows P) the upper plate 60, the installation is completed. As shown in Figures 11A and 11B, the upper plate 60 is now in its locked position, which is maintained by the cooperation coupling means 76 of the spring clip 70 and the corresponding coupling retaining means 67 provided inside the central hole 62 of the upper plate 60. The spring clip is in loaded condition and engages the injector, e.g. by means of the inwardly protruding lips 75 engaging an undercut at the injection port 15, and a further engagement is obtained between the flanges 57 of the lower plate 50 and the openings 77 of the wing portions 72 of the spring clip 70. As shown in Figure 11B, when the upper plate 60 is in its locked position, the error proofing mark 79 becomes visible and guarantees the correct installation of the connector 10.

The connector 10 can also be removed in a simple way without the need of a tool or the like. As shown in Figures 12A and 12B, an inwardly radial pressure can be applied to the inwardly protruding lips 75 (arrows R) of the spring clip 70 while a pushing up action (arrows U) is exerted on the upper plate 60, in order to free the engagement between coupling retaining means 76 of the spring clip 70 and the coupling retaining means 67 of the upper plate 60 which cooperate to retain the upper plate 60 in its locked position.

Once the upper plate 60 can be freely moved upwardly (arrows U), the spring clip 70 returns in its unloaded condition, as shown in Figures 13A and 13B, the inwardly protruding lips 75 are spread apart from the injector and the connector 10 can be extracted from the injector port 15.

5 While at least one exemplary embodiment has been presented in the foregoing summary and detailed description, it should be appreciated that a vast number of variations exist. It should also be appreciated that the exemplary embodiment or exemplary embodiments are only examples, and are not intended to limit the scope, applicability, or configuration in any way. Rather, the foregoing summary and detailed
10 description will provide those skilled in the art with a convenient road map for implementing at least one exemplary embodiment, it being understood that various changes may be made in the function and arrangement of elements described in an exemplary embodiment without departing from the scope as set forth in the appended claims and their legal equivalents.

REFERENCE NUMBERS

5	10	T-shaped connector
	10'	L-shaped connector
	15	injection port
	17	fuel return line
	40	T-shaped connector body
10	40'	L-shaped connector body
	42	connection branch
	43	line branches
	44	through passages
	45	coupling retaining means for the lower plate
15	46	coupling retaining means for the upper plate
	50	lower plate
	51	lower plate flat portion
	52	lower plate central hole
	54	projecting arms
20	55	coupling retaining means for the connector body
	57	lower plate flanges
	60	upper plate
	62	upper plate central hole
	66	coupling retaining means for the connector body
25	67	coupling retaining means for the spring clip

- 70 spring clip
- 71 central portion
- 72 wing portions
- 75 inwardly protruding lips
- 5 76 coupling retaining means for the upper plate
- 77 openings
- 79 error proofing mark
- 100 automotive system
- 110 internal combustion engine (ICE)
- 10 110a engine protrusion
- 110b oil channel
- 110c, 110d surfaces of the engine protrusion
- 120 engine block
- 125 cylinder
- 15 130 cylinder head
- 135 camshaft
- 140 piston
- 145 crankshaft
- 150 combustion chamber
- 20 155 cam phaser
- 160 fuel injector
- 170 fuel rail
- 180 high pressure fuel pump
- 190 fuel source
- 25 200 intake manifold

- 205 air intake duct
- 210 intake air port
- 215 valves of the cylinder
- 220 exhaust gas port
- 5 225 exhaust manifold
- 230 turbocharger
- 240 compressor
- 250 turbine
- 260 intercooler
- 10 270 exhaust system
- 275 exhaust pipe
- 280 exhaust aftertreatment device
- 290 VGT actuator
- 300 EGR system
- 15 310 EGR cooler
- 320 EGR valve
- 330 throttle body
- 340 mass airflow and temperature sensor
- 350 manifold pressure and temperature sensor
- 20 360 combustion pressure sensor
- 380 coolant and oil temperature and level sensors
- 400 fuel rail pressure sensor
- 410 cam position sensor
- 420 crank position sensor
- 25 430 exhaust pressure and temperature sensor

440 EGR temperature sensor

445 accelerator pedal position sensor

450 electronic control unit (ECU)

460 memory system

CLAIMS

1. A quick fit connector (10, 10') for the return line (17) of fuel injectors (160) in an internal combustion engine, comprising:

- a connector body (40, 40') of the T- or L-shaped type having at least one connection
5 branch (42) insertable in a fuel return port (15) of a fuel injector (160);
- a lower plate (50);
- an upper plate (60);
- a spring clip (70),

wherein the upper plate (60) is slidably mounted on the spring clip (70) and the
10 connector body (40, 40'), and wherein the upper plate (60) is movable between an
unlocked position, in which the spring clip (70) is in unloaded condition and free from
any engagement with said fuel injector (160), and a locked position in which the
spring clip (70) is in loaded condition and engages said fuel injector (160) and said
lower plate (50).

15 2. The connector (10, 10') according to claim 1, wherein said connector body (40, 40')
has at least two through passages (44) parallel to said at least one connection branch
(42), and wherein coupling retaining means (45) for said lower plate (50) are provided
inside said through passages (44).

20 3. The connector (10, 10') according to claim 1 or 2, wherein said lower plate (50) has
at least two arms (54) projecting perpendicularly from the plate to slidably engage said
through passages (44), wherein coupling retaining means (55) are provided at the end of
said arms to cooperate with said coupling retaining means (45) provided inside the
through passages (44) of said connector body (40, 40'), and wherein said lower plate
25 (50) has a central hole (52) in which said at least one connection branch (42) is slidably
engaged.

4. The connector (10, 10') according to claim 1, wherein said lower plate (50) has at least two flanges (57) projecting outside from the perimeter of the lower plate (50).
5. The connector (10, 10') according to claim 1, wherein said spring clip (70) has a web-shaped body including at least two wing portions (72) extending from a central portion (71), and wherein inwardly protruding lips (75) are provided at the end of said wing portions (72).
6. The connector (10, 10') according to claim 5, wherein said wing portions (72) are angled outwardly when the spring clip (70) is in unloaded condition and brought toward one another when the spring clip (70) is in loaded condition, said inwardly protruding lips (75) engaging the fuel injector (160) when the spring clip (70) is in loaded condition.
7. The connector (10, 10') according to claims 4 and 5, wherein said flanges (57) of the lower plate (50) abut against said wing portions (72) when said spring clip (70) is in unloaded condition, and wherein said wing portions (72) of the spring clip (70) include openings (77) where said flanges (57) of the lower plate (50) are received in engagement when said spring clip (70) is in loaded condition.
8. The connector (10, 10') according to claim 5, wherein at least one error proofing mark (79) is provided on the external surface of said wing portions (72) of the spring clip (70), and wherein said at least one error proofing mark (79) is concealed by the upper plate (60) in its unlocked position and becomes visible when the upper plate (60) is in its locked position.
9. The connector (10, 10') according to claim 5, wherein coupling retaining means (76) are provided on the external surface of said wing portions (72) of the spring clip (70) for said upper plate (60).
10. The connector (10, 10') according to claim 1, wherein said upper plate (60) includes a central hole (62) engaged on said connector body (40, 40') and on said spring clip (70),

and wherein coupling retaining means (67) are provided inside the central hole (62) to cooperate with said coupling retaining means (76) provided on the external surface of said wing portions (72) of the spring clip (70).

5 11. The connector (10, 10') according to claim 1, wherein coupling retaining means (46) for said upper plate (60) are provided on the external surface of said connector body (40, 40').

10 12. The connector (10, 10') according to claim 11, wherein said upper plate (60) includes a central hole (62) engaged on said connector body (40, 40') and on said spring clip (70), and wherein coupling retaining means (66) are provided inside the central hole (62) to cooperate with said coupling retaining means (46) provided on the external surface of the connector body (40, 40').

13. A method for mounting a quick fit connector (10, 10') to a fuel injector (160) in an internal combustion engine, comprising the steps of:

15 a) providing a quick fit connector (10, 10') comprising a T- or L-shaped connector body (40, 40') and at least one connection branch (42), a lower plate (50), an upper plate (60) and a spring clip (70) arranged between the upper plate (60) and the lower plate (50), wherein the upper plate (60) is slidingly mounted on the spring clip (70) and the connector body (40, 40');

20 b) inserting said at least one connection branch (42) of the T- or L-shaped connector body (40, 40') in a fuel return port (15) of a fuel injector (160);

c) pushing down the upper plate (60) from an unlocked position, in which the spring clip (70) is in unloaded condition and free from any engagement with said fuel injector (160), up to a locked position in which the spring clip (70) is in loaded condition and engages said fuel injector (160) and said lower plate (50).

25 14. The method according to claim 13, wherein said spring clip (70) has a web-shaped

body including at least two wing portions (72) extending from a central portion (71), and wherein inwardly protruding lips (75) are provided at the end of said wing portions (72), wherein said wing portions (72) are angled outwardly and flanges (57) projecting outside from the perimeter of the lower plate (50) abut against said wing portions (72) when the upper plate (60) is in the unlocked position and said spring clip (70) is in unloaded condition, wherein said wing portions (72) of the spring clip (70) include openings (77) where said flanges (57) of the lower plate (50) are received in engagement when said upper plate (60) is in the locked position and said spring clip (70) is in loaded condition, and wherein said inwardly protruding lips (75) at the end of said wing portions (72) engage said fuel injector (160) when said upper plate (60) is pushed down up to the locked position.

15. The method according to claim 13, wherein said spring clip (70) has a web-shaped body including at least two wing portions (72) extending from a central portion (71), wherein at least one error proofing mark (79) is provided on the external surface of said wing portions (72) of the spring clip (70), and wherein said at least one error proofing mark (79) is concealed by the upper plate (60) in its unlocked position and becomes visible when the upper plate (60) reaches the locked position.