

Dec. 1, 1931.

L. L. PHILLIPS

1,834,864

JOINT FOR HIGH TENSION ELECTRIC CABLES

Filed Nov. 24, 1930

Fig. 1.

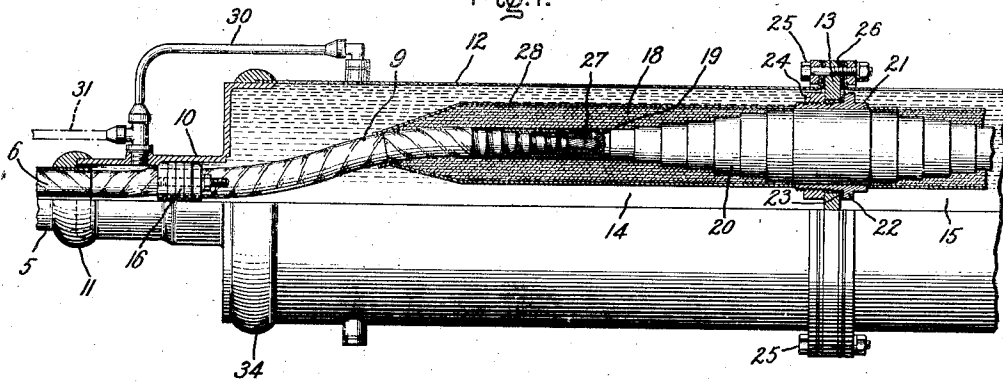

Fig. 2.

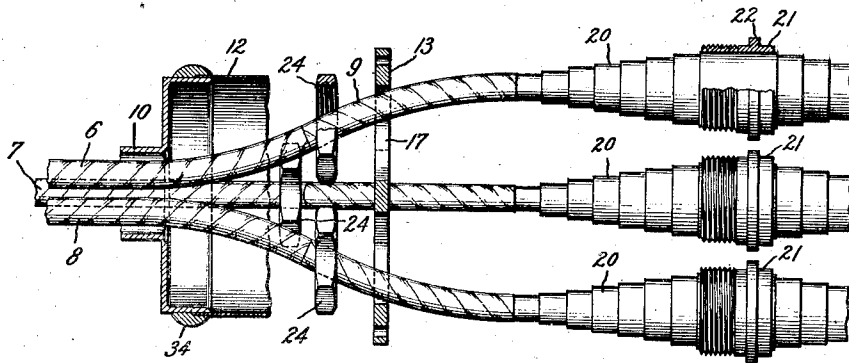
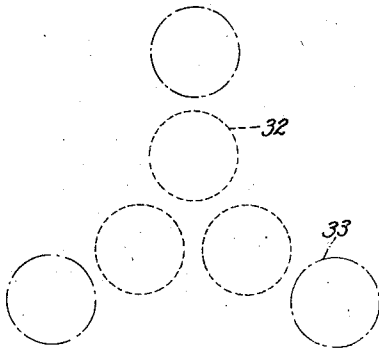

Fig. 3.



Inventor:  
Lester L. Phillips,  
by *Charles T. Ull*  
His Attorney.

# UNITED STATES PATENT OFFICE

LESTER L. PHILLIPS, OF PITTSFIELD, MASSACHUSETTS, ASSIGNOR TO GENERAL ELECTRIC COMPANY, A CORPORATION OF NEW YORK

## JOINT FOR HIGH TENSION ELECTRIC CABLES

Application filed November 24, 1930. Serial No. 497,650.

The present invention relates to what are commonly known as stop-joints for fluid filled electric cable. Their purpose is to electrically connect corresponding ends of cable sections, prevent all migration of the insulating fluid from one section to the other, and to limit the hydrostatic pressure to which the sections of a cable system may be subjected. In making these joints the factory wound insulation is first removed from the conductor ends, then a connector soldered or otherwise secured to said ends, after which a large amount of insulating tape is wound over the connector and also over the permanently wound factory insulation on the conductors themselves. As the operating voltage of the cable is increased, the amount of tape required is likewise increased but at a much greater ratio. The tape as supplied is in the form of rolls and experience has demonstrated that large diameter reinforcements cannot be made sufficiently firm if small rolls each comprising a short length of tape are employed. Small rolls are used because they can be slipped through the small radial spaces between conductors and connectors.

The object of my invention is the provision of an improved form of fluid stop joint for high tension electric cable in which the parts are so arranged that the individual conductors may be temporarily separated to such a degree that relatively large rolls of insulating tape may be used, after which the conductors and their connectors are returned to their proper respective positions and secured in place in such manner as effectively to separate the fluid in one cable section from that in another.

For a consideration of what I believe to be novel and my invention, attention is directed to the accompanying description and the claims appended thereto.

In the drawings which is illustrative of my invention, Fig. 1 is a view partly in section and partly in elevation of a fluid stop joint for a three-conductor oil filled cable; Fig. 2 is a view illustrating the manner in which the partition is moved to one side and the conductors separated, and Fig. 3 is a dia-

grammatic view illustrating the separation of the conductors.

5 indicates the lead sheath of a three-conductor oil filled cable. Only one cable end or section is shown, the opposite end being of similar construction. Within the sheath are three conductors 6, 7 and 8, each of which is covered with factory wound insulation 9 which ordinarily is of paper, but other forms of insulating material may be used. 10 indicates a head which is connected to the cable sheath by a wiped soldered joint 11. The head supports one end of a tubular metal casing 12 which is made in two parts, the plane of division being perpendicular to the axis of the cable and midway between the heads 10. 13 indicates a partition which divides the casing into right and left hand chambers 14 and 15, said chambers being filled with oil or other insulating fluid. The cable sheath also contains oil or other insulating fluid of the same character which has been carefully degasified.

In order to permit of the jointing operation, the cable having been filled with oil prior to installation, semi-stop joints 16 are provided, one in each of the heads 10. These prevent any appreciable flow of fluid from the cable but will not prevent a slow migration of the fluid through the insulation on the conductors.

The partition 13 has as many openings 17 as there are conductors and are equally spaced about the axis of the cable. The diameter of each opening is greater than the diameter of the body of tape insulation 18 which is applied by hand over each conductor joint. The tape for this purpose is supplied in rolls and may be varnished cambric or paper as desired. If paper is used it should be impregnated with oil prior to being applied. 19 indicates a metal connector for connecting the adjacent ends of corresponding conductors. The connector is covered with insulation 20 made of paper or equivalent material and impregnated with a phenolic condensation product so that the insulation as a whole is impervious to the oil contained in the casing. 21 indicates a metal thimble which is forced over the insulation 100

20 of each connector and which holds the insulation under compression at all times, so that no opportunity is afforded for oil to migrate from one side of the thimble to the other whether the parts be hot or cold. The thimble has a flange 22 which is larger than the openings 17 in the partition and when assembled an oil-proof gasket 23 is located between the shoulder and the partition. The thimble is screw-threaded to receive the clamping nut 24. The ends 27 of the conductors are soldered or otherwise secured to the connector.

The parts of the casing 12 are secured to the partition by a series of bolts 25 and packings 26 are provided between the out-turned flanges on the casing and the flat side faces of the partition.

Surrounding the body of hand-applied tape 18 is an electrostatic shield 28 which may be in the form of copper braid spirally wrapped thereon.

30 indicates a by-pass which by-passes oil from one side of the semi-stop joint 16 to the other. 31 indicates a pipe by means of which oil may be supplied both to the cable and to the joint casing.

In order to use long lengths of tape and therefore large diameter rolls the connectors and the cable ends must be separated radially. The procedure is as follows:

The two ends of the cable sections are brought into their proper positions, the connectors are temporarily assembled in the partition, the cable ends cut to their proper length and soldered to the connectors. The nuts 24 are then backed off of the threads of the thimbles and slipped over the individual conductors to the positions shown in Fig. 2. The partition is likewise moved to one side. The respective ends of the cable are then pulled toward each other and at the same time the conductors spread from their normal positions, which are those indicated by the dotted lines 32 in Fig. 3 to the broken and dotted lines 33. With the conductors and connectors thus widely separated and the partition 13 in its extreme left-hand position, the bodies of tape 18 are applied to the amount indicated in Fig. 1. After all the tape bodies have been applied and also the shields 28 the conductors are moved inward to their proper positions and the partition 13 is moved back to its proper place with each thimble 21 occupying its particular opening. The nuts 24 are then moved along the conductors and over the bodies of insulation 18 and screwed into place on the thimbles. After this is done, the parts of the casing are slipped endwise into engagement with the partition and are bolted into place. The outer ends of the casing are then secured to the heads by wiped soldered joints 34.

Certain of the operations of preparing the joints and evacuating the joint containing

casing have been omitted as being unnecessary to an understanding of my invention, but it is to be understood that in these particulars any suitable or well-known procedure may be followed.

By reason of my improved construction, rolls of tape of substantially larger diameter than those employed heretofore may be used, with the result that the bodies of tape over the connectors and conductor ends will have fewer joints and will be much more dense than where short pieces are used and hence the joints will be less liable to injury when in service due to the presence of voids.

What I claim as new and desire to secure by Letters Patent of the United States, is:

1. A stop joint for multi-conductor fluid filled cable, comprising sheathed cable sections, each containing fluid and separately-insulated conductors, a transverse metal partition having as many openings as there are conductors, each of said openings having a diameter greater than that of the insulation on a conductor to permit of the partition being temporarily moved to one side of its normal position, a connector which extends through each of the openings and is covered by insulation which is impervious to the fluid in the cable, a metal thimble surrounding the insulation on each connector and holding the same under compression at all times, means for securing the thimbles within the openings in the partition and preventing the migration of fluid from one side thereof to the other, bodies of insulating tape applied over the ends of each connector and the conductors united thereby and their insulations, and a divided casing united fluid-tight to the cable sheaths at its outer ends and to the partition at the center.

2. A stop joint for multi-conductor fluid filled cable, comprising sheathed cable sections, each containing fluid and separately insulated conductors, a transverse metal partition which has as many openings as there are conductors, each of said openings having a diameter greater than that of the insulation on the conductor to permit of the partition being temporarily moved to one side of its normal position, an insulated connector for each conductor which extends through one of the openings and is covered by insulation that is impervious to the fluid in the cable, a metal thimble surrounding the insulation on the connector and holding the same under compression at all times, said thimble having a shoulder on one side of the partition and a screw thread on the other, threaded means for securing the thimbles in place, bodies of insulating tape applied over the ends of the connector and the insulation thereon and that on the conductors, the diameter of which is less than that of the corresponding opening in the partition, and a divided casing containing fluid and united

at its outer ends to the cable sheaths and to the partition at its center.

5 3. A stop joint for multi-conductor fluid filled cable, comprising sheathed cable sections, each containing fluid and separately  
10 insulated conductors, a movable transverse metal partition having as many spaced openings as there are conductors, an insulated connector for each conductor extending through  
15 an opening in the partition, a thimble on each connector extending through the partition which holds the insulation thereon under compression at all times to prevent migration of the fluid, means for securing each  
20 thimble independently to the partition by a fluid-tight joint, taped insulation over the joint between each connector and the conductors secured thereto; a casing comprising two tubular members having flanges on opposite  
25 sides of the partition, means for securing the flanges to the partition, heads at the ends of the casing members united thereto and to the cable sheaths, semi-stop joints in the heads to prevent the free flow of fluid from the cable sections into the casing during the  
30 jointing operation, and a by-pass around each of said semi-stop joints from the cable sheath to the casing.

In witness whereof, I have hereunto set  
30 my hand this 21st day of November, 1930.

LESTER L. PHILLIPS.

35

40

45

50

55

60

65