

Jan. 31, 1967

R. REEBER ETAL

3,301,207

LOOPER DRIVE MECHANISM FOR CHAINSTITCH SEWING MACHINES

Filed Oct. 24, 1963

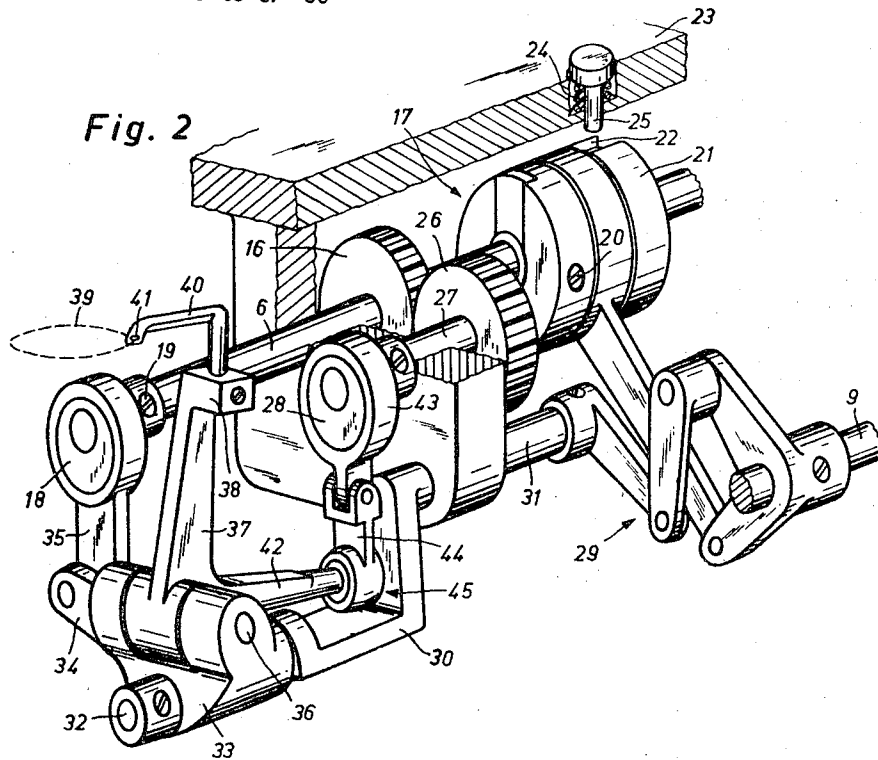
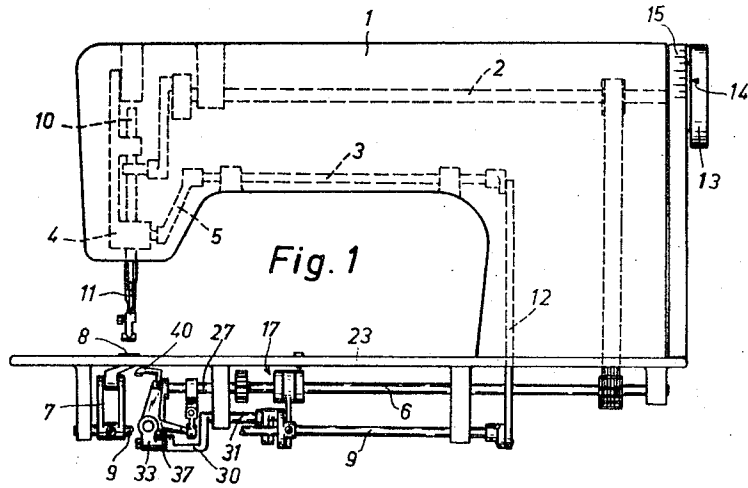

INVENTORS  
RUDOLF REEBER &  
HELMUT GROSS  
BY *W. H. 106*  
ATTORNEY

1

2

3,301,207  
**LOOPER DRIVE MECHANISM FOR CHAIN-STITCH SEWING MACHINES**

Rudolf Reeber, Neukeferloh uber Munich, and Helmut Gross, Kaiserslautern, Pfalz, Germany, assignors to G. M. Pfaff A.G., Kaiserslautern, Pfalz, Germany, a corporation of Germany

Filed Oct. 24, 1963, Ser. No. 318,612  
Claims priority, application Germany, Oct. 24, 1962,  
P 30,430  
6 Claims. (Cl. 112—200)

The present invention relates to improvements in double chainstitch sewing machines more particularly of the type including work feeding means preferably, though not limitatively, of the combined type comprising a lower feed dog and upper feed means in the form of at least one oscillating needle, said machines further comprising at least one chainstitch looper supported by a carrier being subjected to movements transverse to the feed direction and along a substantially elliptical path in synchronism with said feed means, said movements being comprised of a pair of geometrically combined oscillating components in line with the transverse to the feed direction, respectively. As an example, the first of said components may be produced by means of a first eccentric operably connected with the main drive shaft of the machine, to effect movements of the looper in one of the coordinate directions, and the second of said components may be similarly produced by means of a second eccentric connected with said shaft, to effect movements of the looper in the coordinate direction. One of the looper movements has a direction to effect a proper loop seizing and shedding action, while the other looper movement is in a direction to cause a needle avoid action, to ensure proper stitch formation and freedom from collision between the needle and looper, as well as from other defects well known. In order to enable operation with varying feed strokes or stitching lengths, it has furthermore been proposed to combine the needle avoid looper movement with a variable movement derived from a feed or stitch controller, to ensure safe and reliable stitch formation within a desired range of stitching length or feed stroke variation.

Thus, in a known machine of this type, as exemplified by U.S. Patent No. 2,950,695, the carrier supporting the looper is secured to a rockshaft which extends over the entire length of the cloth supporting arm of the machine within and at the end of which is disposed a feed dog of usual construction. During a sewing operation, the rockshaft is subjected to component movements both in the direction of and about its axis, in such a manner as to impart to said looper a movement in a direction transverse to the feed direction, on the one hand, as well as a variable movement being in line with the feed direction and determined by the feed stroke or stitch length adjustment, on the other hand. The transmission of the movements upon the rockshaft and upon the work feeding devices is effected through pull bars and rocking cranks operated by a single drive shaft, whereby the rocking crank for the constant movement may be journaled between the arms of the rocking crank for the variable feed movements, in such a manner that both said movements may be superposed in either additive or subtractive relation. The oscillating needle feed cooperating with the feed dog may also be derived from the main drive shaft through a further eccentric drive and operating mechanism.

It is furthermore known, as exemplified by U.S. Patent No. 2,884,883 to provide a looper in a flat bed machine operated in the direction transverse to the feed direction

and a needle operated at right angle to the longitudinal axis of the cloth plate of the sewing machine. In this case, the loop seizing and shedding movements of the looper are effected by way of a looper support or carrier which is journaled about a supporting pin secured to and being at right angle to the axis of a rockshaft driven from the main drive shaft of the machine. With such an arrangement it is necessary, upon variation of the feed stroke or stitching length, to adjust the engaging points of a plurality of pull bars by a system comprising three guide and slide block units and thereafter to conform the needle feed movement with a feed dog and looper movement.

Machines equipped with a looper mechanism of the foregoing type i.e. with the looper being operated in a direction transverse to the feed direction, have the advantage that auxiliary means in the form of a thread-spreading device or the like assisting the operation of the looper may be dispensed with, provided, however, that the feed stroke of the needle and feed dog, upon change of the stitching length, are adjusted by exactly equal amounts in an effort to ensure a proper cooperation between the looper, the oscillating needle and the feed dog or dogs, respectively. There is required for this purpose control mechanism of such size and bulk as to make it difficult or impossible to accommodate the same within the available mounting space of a conventional sewing machine.

Besides, with conventional machine designs a safe and satisfactory interlock between the upper and lower threads is possible only by the use of a needle having a predetermined diameter for which the machine has been especially designed and/or adjusted. Diameters differing from the normal needle diameter are liable to interfere with the proper stitch formation, whereby the result is failing stitches, collisions between the needle and the looper and other defects and drawbacks well known.

Finally, it is not possible with machines of known type, including those referred to herein, to adjust the looper for the sewing together of two work pieces arranged with their edges in register by a covering seam or stitch known as type 402 or the like according to the Federal Standards and utilizing two or more needles cooperating with a single looper.

Accordingly, among the objects of the present invention is the provision of a chainstitch sewing machine of the referred to type embodying improved looper operating mechanism which is substantially devoid of the above-mentioned as well as related defects and difficulties; which if equipped with needle feed means with or without a lower feed dog, will not require any adjustment or control of the cooperation between the needle, the feed dog and looper movements; which will enable a control of the elliptical looper path, such as to ensure efficient and satisfactory stitch forming conditions for varying needle diameters or during the sewing of different types of fabrics, respectively; which will readily enable the sewing of 402 type or the like stitches; and which is both simple in design and use, as well as efficient and reliable in operation.

The invention, both as to the foregoing and ancillary objects, as well as novel aspects, will be better understood from the following detailed description of a preferred practical embodiment, taken in conjunction with the accompanying drawing forming part of this specification and in which:

FIG. 1 is a front view of a chainstitch sewing machine equipped with looper operating and control mechanism according to the invention; and

FIG. 2 is a perspective detailed view more clearly illustrating the looper operating mechanism in relation to the cooperating elements of the machine shown in FIG. 1.

3

Like reference numerals denote like parts in both views of the drawing.

With the foregoing objects in view, the invention involves generally the provision in a double chainstitch sewing machine of the type having a rotary drive shaft, work feeding means in the form of an oscillating needle, and a thread-carrying looper arranged for coordinated loop seizing and shedding movements and for needle avoid movements along a substantially elliptical path, of improved mechanism to operate said feeding means and said looper, said mechanism comprising a stitch controller preferably of the eccentric type mounted upon said shaft, and first motion-transmitting means operably connecting said controller with said feeding means, to vary the feed stroke or stitching length.

There is further provided in accordance with the invention multiple drive mechanism between said stitch controller and drive shaft, on the one hand, and said looper, on the other hand, in the form of a Cardan-type suspension mechanism comprising an input member having a control shaft rotatable about a first and fixed axis, an output member supporting said looper and rotatively mounted upon said input member about an axis including a preferably right angle with said first axis. The drive shaft is connected with the input member of said mechanism through suitable second motion-transmitting means, such as an eccentric drive, to impart to said member a substantially constant rocking movement about said first axis and the drive shaft is further connected with the output member of said mechanism through third motion-transmitting means also preferably consisting of an eccentric drive, to impart to said output member motion about said second axis, whereby to operate said looper along the desired elliptical path in transverse to the feed direction and in synchronism with the needle feed movements.

Finally, there is provided in accordance with the improvements of the present invention motion-transmitting means operably connecting the first motion-transmitting means with the control shaft of said mechanism, to additively combine the constant oscillating motion of a member of said Cardan mechanism with a component varying in proportion to the feed stroke or stitching length adjustment.

In other words, the Cardan mechanism for the looper is arranged or utilized to function both as a geometric summation device in combining the input movements determining the elliptical operating path of the looper, on the one hand, and in arithmetically combining the constant and variable components of one of said movements determining the needle avoid action within the composite looper path or movement, said variable component being derived from the stitch controller and varying in proportion to the feed stroke or stitching length adjustment, in a manner as will become further apparent from the following detailed description in reference to the drawing.

Mounted in a known manner within the housing 1 of the machine are the main rotary drive shaft 2, the needle operating rockshaft 3 which terminates in a crank 5 engaging the needle oscillator or support 4, the looper drive shaft 6, and the rockshaft 9 operating a feed dog 8 by way of a support or carrier 7. As a consequence, the needle oscillator 4 within which is mounted the needle bar 10 carrying the needle 11 in axially reciprocating relation causes the needle to oscillate in the feed direction, in a manner well known in connection with needle feed type sewing machines. The needle rockshaft 3 may be driven from the rockshaft 9 operating the feed dog 8 through a link 12, shaft 6 being connected to shaft 9 through the stitch-controller 17 and suitably driven from the main drive shaft 2 of the machine by a belt or the like drive means, as shown in the drawing.

Mounted upon the main drive shaft 2 is a hand wheel 13 being provided with an index 14 arranged to cooperate

4

with a fixed scale 15 calibrated in stitching length and applied to the housing 1. Mounted upon the looper rockshaft 6 are a gear 16, FIG. 2, the eccentric drive and stitch controller 17 relatively angularly adjustable in a known manner in respect to said shaft, and a further eccentric 18, both said eccentrics being fixed by means of set screws 19 and 20 or the like securing means, respectively. The adjusting ring 21 of the stitch controller 17 has a peripheral notch or groove 22 arranged to be engaged by a pin 25 slidably mounted within the cloth plate 23 of the machine and being subject to the action of a return spring 24. Pin 25 serves to lock the ring 21 of the stitch controller for adjusting the stitching length in the manner well known in the operation of eccentric stitch-controllers of this type. Meshing with the gear 16 is a second gear 26 having a shaft 27 which carries a further adjustable eccentric 28.

With further reference to the eccentric drive and stitch-controller 17, this may be of the general type, as shown for instance by U.S. Patents 2,128,031, 2,161,579, 2,491,449 and 2,950,695, comprising essentially a first member fixedly mounted upon the shaft 6 (through set screw 20) and a second member 21 freely rotatable upon said shaft, within a limited angular range, relative to said first member. Supported in radially adjustable relation, via a cam and groove or the like connection, is the driving eccentric proper embraced by the eccentric rod connecting the controller with the motion-transmitting mechanism 29. As a consequence, arresting of the member 21 by the pin 25 and rotation of the first member, via the handwheel 13 and shaft 6, will result in the displacement of the eccentric relative to the shaft 6, whereby to vary its degree of eccentricity relative to the shaft 6 and, in turn, the amplitude of the reciprocating movement imparted to the mechanism 29, in a manner well known and described in further detail by Patent 2,950,695 referred to hereinabove.

The linkage mechanism 29 serves to apply oscillating movements to both the rockshaft 9 of the feed dog 8 and the needle 11 (via link 12), on the one hand, and to a further rotating shaft 31 terminating in the crank 30, on the other hand. Crank 30 has a pin or shaft 32 which serves as a rotary support for the input member 33 of the Cardan-type looper operating mechanism. Member 33 has a lateral extension 34 which is linked to the eccentric arm 35 having its free ring-shaped end embracing the eccentric 18. The member 33 is furthermore fitted with a shaft 36 being at right angle to the pin or shaft 32 and serving to rotatively support a carrier arm or output member 37 to which is connected the looper 40 having an eye 41 by way of an intermediate support or block 38. In place of a single looper as shown in the drawing, a plurality of loopers may be supported by the block 38 for cooperation with a corresponding number of needles for the production of special stitches or seams, in a manner well known to those skilled in the art.

Further connected to or extending from the output member 37 is an arm or lever 42 having its free end connected through a universal or ball joint 45 to the end of a link 44 being connected to the eccentric arm 43 embracing the eccentric 28, as shown and understood from the drawing.

The following is a description of the operation of the invention in reference to the drawing.

As pointed out, arresting of the member 21 of the stitch-controller 17 by depression of the pin 25 and rotation of shaft 6 via the handwheel 13, to adjust a desired stitching length, results in the angular displacement of the driving eccentric (not shown) of the stitch-controller, thereby in turn varying its eccentricity determining the amplitude of the reciprocating movement imparted to the rock shafts 9 and 31 via mechanism 29. As a consequence, the adjustment of the stitch-controller 17 is transferred to both feed devices, that is, the feed dog 8 (via shaft 9) and the oscillating needle 11 (via shaft 9 and link 12), on the one

hand, and to the looper drive mechanism (via shaft 31), on the other hand.

Referring to the operation of the looper drive mechanism, the eccentric 28 applies, via ring 43, pull rod 44, ball joint 45, lever 42, and carrier 31, loop-seizing and shedding movement to the looper 40 transverse to shaft 36, or to the work feeding direction, while the eccentric 18 acts to displace the looper 40, via pull rod 35, member 33 and member 37, through a constant needle-avoid oscillating movement in line with the feed direction, both said movements resulting in the elliptical operating path 39, in a manner well known from the operation of oscillating chain stitch loopers of this type.

Due to the mounting of the member 33 upon the pin 32, shaft 31 also acts to displace, via crank 30 and member 33, the looper 40 in line with the feed direction, that is, in addition to the constant needle-avoid feed movement produced by the eccentric 18. This additional displacement, being proportional to the feed stroke or stitching length, is automatically varied in accordance with the stitching length adjustment by the handwheel 13, in the manner described and understood.

There is superimposed in this manner upon the path 39 of the looper corresponding to zero feed stroke adjustment, an additional oscillating movement in the feed or needle-avoid direction corresponding to the feedstroke of the needle 11 and feed dog 8 set by the stitch-controller 17, to thereby secure a proper stitch-forming operation for any stitching length adjustment of the controller 17.

Upon exchange of the needle 11 by a needle of different diameter, the distance between the needle and looper 40, which during the penetration of the needle into the thread triangle should be practically equal to zero, may be simply re-adjusted by adjusting the angular position of the eccentric 18 relative to the position of the eccentric 28 by loosening the screw 19 and rotating eccentric 18, whereby the eccentric 28 retains its phase position relative to the remaining parts of the drive mechanism. As a result of the adjustment of the relative phase positions of the eccentrics 18 and 28, the elliptical looper path 39 will be slightly distorted without varying the respective absolute magnitudes of the loop seizing and needle-avoid movements. This distortion is sufficient to adapt the path of the looper 40 to varying needle diameters.

In the foregoing, the invention has been described in reference to a specific illustrative device. It will be evident, however, that variations and modifications, as well as the substitution of equivalent elements or devices for those shown and described herein for illustration, may be made without departing from the broader purview and spirit of the invention as set forth in the appended claims. The specification and drawings are accordingly to be regarded in an illustrative rather than in a restrictive sense.

We claim:

1. In a chainstitch sewing machine of the type including a rotating drive shaft, a needle having a needle holder and arranged for both reciprocation, to form stitches, and oscillation in line with the feed, to act as work feeding means, and an oscillating looper arranged for coordinate loop-seizing and shedding movement transverse to and for needle-avoiding movement in line with the feed, to result in a substantially elliptical operating path of said looper, operating mechanism comprising in combination:

(1) an adjustable stitch-controller driven by said shaft and adapted to produce variable-amplitude oscillating output movement,

(2) first motion-transmitting means connecting said stitch-controller with said needle holder, to impart oscillating feed movement to said needle,

(3) drive means for said looper comprising a first member rotatably mounted on a first shaft having a first axis, a second member supporting said looper and rotatively mounted upon said first member about a second axis substantially at right angle to said first axis a control shaft rotatable about a fixed axis paral-

lel to but spaced from said first shaft and operably connected thereto, to impart thereto an oscillating motion,

(4) second motion-transmitting means connecting said drive shaft with said first member, to impart thereto a substantially constant oscillating movement about said first axis in line with the feed,

(5) third motion-transmitting means connecting said drive shaft with said second member, to impart thereto a coordinate oscillating movement about said second axis substantially transverse to the feed, whereby to oscillate said looper along said elliptical path, and

(6) fourth motion-transmitting means operably connecting said stitch-controller with said control shaft, to superimpose a variable-amplitude oscillating motion proportional to the feed stroke upon the constant oscillating motion of said first member, thereby to control the needle-avoiding movement of said looper in dependence upon the feed stroke adjustment of said stitch-controller.

2. In looper operating mechanism for chainstitch sewing machines as claimed in claim 1, said stitch controller being of the eccentric type including an eccentric rod, and multiple linkage mechanism operably connecting said rod with both said needle holder and said control shaft, respectively.

3. In looper operating mechanism for chainstitch sewing machines as claimed in claim 1, each of said second and third motion-transmitting means being comprised of an eccentric having an eccentric rod and driven by said drive shaft and linkage means operably connecting said eccentric rods with said first and second members, respectively.

4. In looper operating mechanism for chainstitch sewing machines as claimed in claim 1, each of said second and third motion-transmitting means being comprised of an eccentric driven by said drive shaft and linkage means operably connecting said eccentrics with said first and second members, respectively, and said stitch controller being of the eccentric type also mounted upon said drive shaft and having an eccentric rod, and multiple linkage mechanism operably connecting said rod with said needle holder and said control shaft, respectively, to vary the stitching length and to control the varying motion superimposed upon the constant motion of said first member in dependence upon the feed stroke adjustment of said stitch-controller.

5. In looper operating mechanism for chainstitch sewing machines as claimed in claim 1, each of said second and third motion-transmitting means comprising an auxiliary eccentric driven by said shaft and linkage means connecting each of said auxiliary eccentrics with said first and second members, respectively, and means to adjust the angular position of the auxiliary eccentric driving said first member.

6. In looper operating mechanism for chain-stitch sewing machines as claimed in claim 1, including an additional feed dog with further motion-transmitting means connecting the same with said stitch-controller for operation in synchronism with the needle feed oscillations.

#### References Cited by the Examiner

##### UNITED STATES PATENTS

1,127,069	2/1915	Molyneux	112—200
1,450,456	4/1923	Seymour	112—213
1,510,633	10/1924	Seymour	112—213 X
3,482,079	9/1949	Zeier	112—199
2,884,883	5/1959	Reimer	112—200 X
2,950,695	8/1960	Benink et al.	112—200

JORDAN FRANKLIN, *Primary Examiner.*

R. J. SCANLAN, *Assistant Examiner.*