

(No Model.)

H. W. READE.
FILING CASE.

No. 329,676.

Patented Nov. 3, 1885.

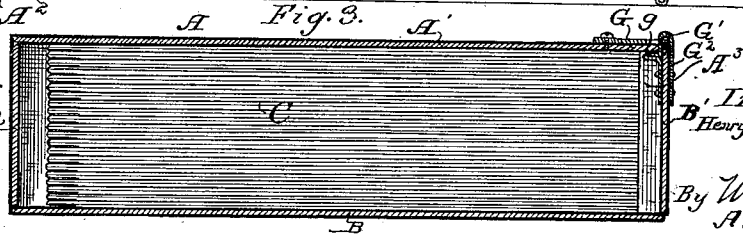
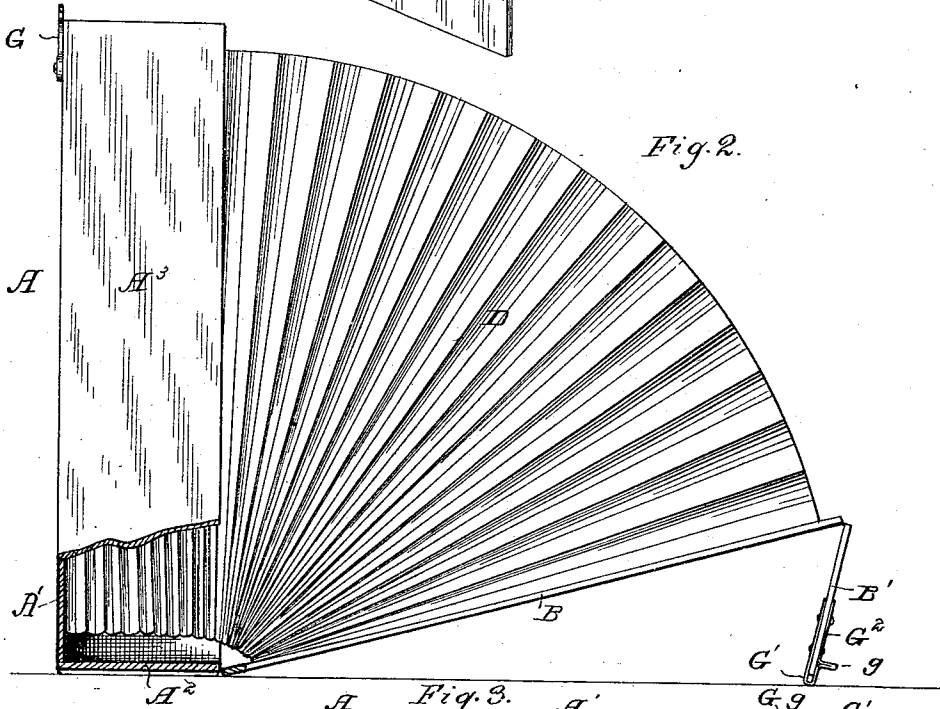
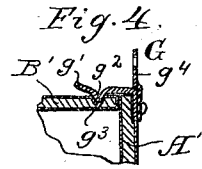
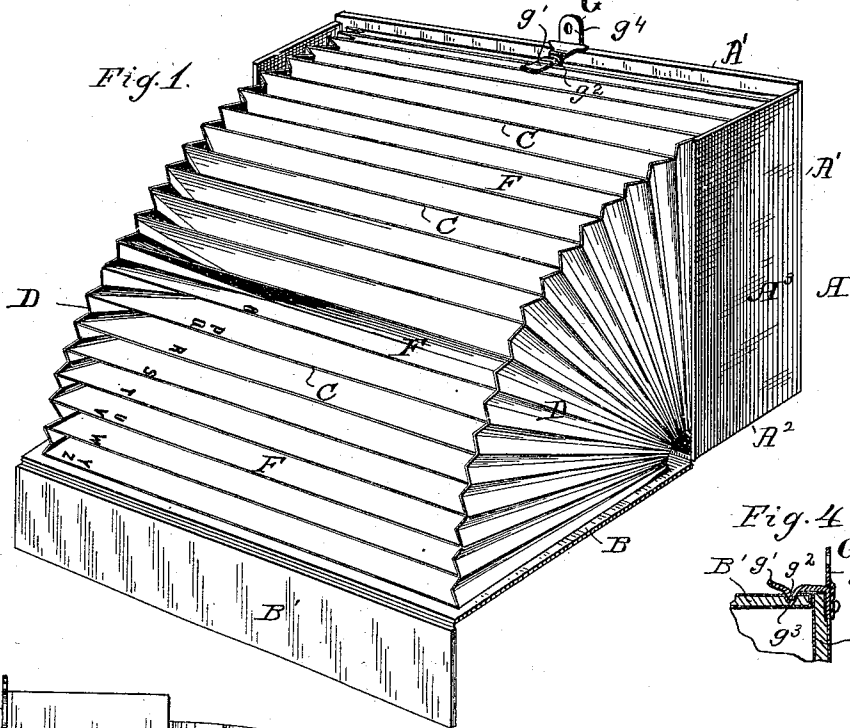

Witnesses:
G. Hugel, H²
C. C. Poole

Inventor
Henry W. Reade
By W. S. Dyer
Attorney.

UNITED STATES PATENT OFFICE.

HENRY W. READE, OF CHICAGO, ILLINOIS.

FILING-CASE.

SPECIFICATION forming part of Letters Patent No. 329,676, dated November 3, 1885.

Application filed September 15, 1884. Serial No. 143,167. (No model.)

To all whom it may concern:

Be it known that I, HENRY W. READE, of Chicago, in the county of Cook and State of Illinois, have invented certain new and useful Improvements in Filing-Cases; and I do hereby declare that the following is a full, clear, and exact description thereof, reference being had to the accompanying drawings, and to the letters of reference marked thereon, which form a part of this specification.

This invention relates to temporary files or filing-receptacles for letters and papers; and it consists in the matters hereinafter described, and pointed out in the claims.

The filing-receptacle herein illustrated as embodying my invention comprises a shallow rectangular box or receptacle having a hinged cover and a series of leaves attached at their side margins to folding side pieces or gussets secured at their edges to the bottom of the box and to the inner surface of the cover, so as to form a series of pockets adapted to contain the letters or papers to be filed, as will be hereinafter more particularly described.

In the accompanying drawings, Figure 1 is a perspective view of a filing-receptacle constructed in accordance with my invention, shown as suspended upon a vertical surface or wall with the hinged cover thereof open. Fig. 2 is a side view of the same when open and resting upon a horizontal surface. Fig. 3 is a vertical cross-section of the same, showing the cover closed. Fig. 4 is a detail view of the fastening device shown in Fig. 1.

A is the box or receptacle, which is composed of a bottom, A', a back piece, A², and two side pieces, A³ A³, and is provided with a cover, B, which is hinged at its rear edge to the upper edge of the back piece, A², and is provided at its front or free edge with a hinged flap, B', adapted to close the front of the receptacle when the top or cover is closed.

C C is a series of leaves, which are connected with each other at their inner margins, as shown, and are attached at their side edges to side pieces or gussets, D D, which are of flexible material, and folded in zigzag cross-sectional shape, so as to form in connection with the leaves C a series of folding-pockets, F, for receiving the papers to be filed. The side pieces, D, are secured at their end margins to the bottom A' of the receptacle,

near the sides A² thereof, and also to the cover B, so that when the cover is opened the several pockets will be opened out or spread so as to permit the papers to be filed to be readily inserted therein. The inner edges of the leaves C C, which are adjacent to the bottom A' and cover B, are also secured to the said bottom and cover, and the inner edges of all the said leaves preferably terminate and are united with each other at a point somewhat distant from the back piece, A², as shown in Figs. 2 and 3, so as to prevent the said leaves from striking or rubbing against the said back piece in the opening and closing of the receptacle. The cover B and flap B' thereon are preferably arranged to overlap the edges of the side pieces, A², of the receptacle, so as to rest upon said side pieces when the said cover is closed.

In the construction shown in Figs. 2 and 3 the flap B' upon the cover is extended over the edge of the bottom A' when the cover is closed, and the said cover is held in its closed position by means of a locking device consisting of a hook, G, pivoted to the bottom A', and adapted to engage a loop or eye, G', formed by a bent metal strip, G², secured upon the cover-flap B' by being bent over the said flap and held by rivets or otherwise. The metal strip G² is, as herein shown, bent to form a projection, g, adapted to engage the edge of the bottom A', and to thereby serve as a stop to hold the eye G' in position with reference to the edge of the bottom, so as to be properly engaged by the hook thereon.

The receptacle and cover will usually be made of pasteboard or other thin material that is to some degree flexible, and the stop or projection g is used in connection with the hook G or any other fastening device upon the bottom and flap to hold the middle part of the bottom from being pressed inwardly past the edge of the flap when the receptacle is closed.

In the form of the receptacle shown in Fig. 1, which is more particularly intended for hanging upon a vertical surface, the edge of the bottom A' is arranged to extend over the edge of the flap when the cover is closed, and a spring-catch, g', having a projection, g², adapted to engage a recess or depression, g³, in the flap B', is secured to the bottom A', as clearly shown in the detail sectional Fig. 4. As shown in Figs. 1 and 4, also, a loop or eye,

g', is secured to the upper edge of the bottom A' for engagement with a stud or nail in suspending the receptacle upon a wall or other vertical surface.

5 Neither of the particular forms of fastening devices herein shown for securing the flap B' to the bottom A' is essential in carrying out the invention, and any convenient or desirable device may be used for this purpose; or
10 any particular fastening device for connecting the flap with the receptacle may be dispensed with, and a tape or string or strings, either attached to the parts of the receptacle or separate therefrom, may be used for keeping the
15 receptacle closed.

The flap B' need not necessarily be attached to the cover B, as shown, but may be connected with the edge of the bottom A' with advantageous results. The construction shown is
20 preferred, however, for the reason that in case the cover B and flap B' are separately hinged to the receptacle the flap would rest over the pockets adjacent to the bottom A' when closed, and would have to be opened or thrown back as a separate operation in opening the recep-
25 tacle.

When the receptacle described is hung vertically, as shown in Fig. 1, and the cover is opened, the latter will fall forward, as shown,
30 and thereby retain the several pockets F open for the convenient insertion of letters. When the receptacle is placed upon a horizontal surface, the pockets may be also held open in the same manner by placing the receptacle
35 with its back A² horizontal and its bottom A' vertical, and allowing the free edge of the cover B to rest upon the surface of the table. In case the size of the side pieces or gussets, D, or the number of pockets is such that the
40 cover will not freely open so as to rest horizontally upon the table or other surface upon which the receptacle is supported, the free end of the said cover may be sustained by the flap B', as clearly shown in Fig. 2, and the
45 main portion A of the receptacle will thereby be held against any tendency to fall over upon the cover. When the cover B is sustained by the flap B' in the position last described, also, all of the pockets F are presented in a position
50 more favorable for the convenient insertion of the papers therein than would be the case were the pockets adjacent to the cover horizontal.

The leaves C, which divide the pockets, will usually be provided with suitable index letters or characters, which may be either
55 printed or stamped upon the outer margins of the covers themselves, as herein shown, or placed upon projecting pieces or tags secured to the said leaves in a well-known manner.
60

In index filing-cases as heretofore usually constructed it is necessary to shift or move index-leaves or other papers previously placed
65 in the file, in putting each paper in its proper place, and the operation of filing a number of papers thus becomes a tedious and lengthy operation. In the use of the receptacle con-

70 structured as herein described, however, the several index-leaves are held apart or separated by the action of the gussets D connected therewith, so that all of the pockets are held open to receive the papers or letters, where-
75 by the latter may be readily and quickly assorted and deposited under their appropriate letters or headings in the file.

Another advantage of the construction described is that when the receptacle is closed the several pockets are covered, and the pa-
80 pers therein are thereby protected from dust and dirt. The outer case or cover also gives the file or receptacle a neat and attractive appearance, and enables it to be readily handled without liability of displacing the papers therein.

The file when closed may obviously be
85 placed upon one end upon a shelf, like a book, or it may be arranged in a cabinet, or stacked up with other similar files, and the papers therein will in all cases be held properly in place and protected from access of dust.
90

The sides A³ and flap B' of the receptacle, while convenient for the purposes above stated, are obviously not concerned in the results of greater convenience and utility obtained by the presence of the pockets F, con-
95 nected with the case, as described, and my invention as set forth in the appended first claim is not therefore limited to the precise construction of the case herein shown.

It is to be understood also that the appended
100 claims cover the several parts set forth therein when the said parts are in form to obtain either, any, or all of the functions or advantages belonging to or obtained by the use of said parts in the particular form of the de-
105 vice shown.

I claim as my invention—

1. A filing-case comprising a box or re-
110 ceptacle, as A, provided with a wide back or bottom, A², and with a side or cover, B, hinged to said back or bottom, a series of index-sheets, and folding webs or gussets attached to the receptacle and cover and to the side margins of the sheets, operating to hold said leaves apart when the receptacle is open,
115 and forming with said leaves a series of pockets for containing the papers to be filed, substantially as described.

2. The combination, with the box or re-
120 ceptacle comprising a side wall, A', a back, A², and side pieces, A³, of a cover, B, hinged to the back A², and provided with a flap, B', and a series of index-sheets, C, and gussets D, forming pockets F, said gussets being attached to the wall A' and cover B,
125 substantially as described.

In testimony that I claim the foregoing as my invention I affix my signature in presence of two witnesses.

HENRY W. READE.

Witnesses:

C. CLARENCE POOLE,
OLIVER E. PAGIN.