

(19) (KR)  
(12) (A)

(51) 。 Int. Cl.7  
G11B 25/06  
G11B 23/07

(11)  
(43)

10-2004-0084886  
2004 10 06

(21) 10-2004-7001361

(22) 2004 01 30

2004 01 30

(86) PCT/EP2003/000751

(87)

WO 2003/071542

(86) 2003 01 24

(87)

2003 08 28

(30) 10/080,069 2002 02 21 (US)

(71) 10504

(72) 85749 . 3148

85750 . 8341

85750 . 4360

85641 . 11500

(74)

:

(54)

LTO 가 , LTO 가 LTO 가 LTO 가 LTO 가

l) (Magstar) (LTO) (library cel  
 (catridge loader),  
 가 (Media)  
 가 가  
 (ACL) (storage cell)  
 가 (magazine)  
 (automated pickers)  
 (gripper arms) / 가  
 (gripping notches)  
 가 LTO ECMA( )  
 , IBM 3590110  
 1 3 (10) (20) ( (14)  
 (12) (ridge)(16) 4 (22) (26)  
 가 (12) 가 (24) (2  
 8) (18) (16) (30) (32,34)  
 (10)가 ( ) 가 (38) (36)가  
 CMA) (12) (38) 30° ( ) (E  
 , IBM Ultrium/LTO 5 7 LTO (40)  
 (44,46) (42)  
 tible picker)(50) 8 LTO (compa  
 (56) (52,54) (finger)(58) (40)  
 (60,62) (64) (40)가 LTO (40)  
 가 ( ) (64) (66)가  
 (40) (70) V (68) 가  
 가 (42) 가 4.75mm 가 8.70

mm , (40) 14mm 20mm 6.00mm ± 0.25mm 가 .  
 (60) 가 5mm 3.00mm ± 0.08mm . ( )  
 60) 20.50mm ± 0.20mm 11.45mm ± 0.20mm .  
 (62) 가 5mm 4.8mm 3.00mm ± 0.08mm  
 (62) 20.50mm ± 0.20mm  
 (60) 86.15mm ± 0.25mm ( ) 7.80mm ) . V (68)  
 가 8.90mm 5.05mm 1.50mm  
 가 (68) V (68) 60 ° ± 1 °

(leader block)

, LTO

(leader pin)

가

LTO

LTO

LTO

LTO

LTO

LTO

가

, LT

O

LTO  
가

LTO

LTO

가

LTO

(library bins)

LTO

(spring-loaded retaining pin)

LTO

LTO

1

2 1

3

1

4

5 LTO .  
 6 5 .  
 7 5 .  
 8 , LTO  
 9 .  
 10 9 .  
 11 9 .  
 12 9 .  
 13 9 .  
 14 9 .  
 15 9 .  
 16 9 .  
 17 가 , 9 .  
 18 17 .

가 (30) LTO 가 (42) LTO 가 LTO 가 LTO  
 , 가 , LTO ECMA-196 ECMA-999  
 가 가 (tape ree  
 l) 가 가 가 가 가 가 가 가  
 0) (80) (82) (16) (80) (90) (80) (90) (80) (90)  
 dge)(86) 가 (84) (88) (80) (90)  
 LTO (88)  
 , 11 12 (80) (92) LTO  
 . , 9 (w1) 1.8mm (94,96)

109mm ± 0.32mm 105.4mm ± 0.30mm (98)  
 (92) 19.0mm LTO ( 1 )  
 30) (42) LTO ( 5 ) LTO ( )  
 (100) LTO (100) 가  
 4.75mm 가 8.70mm (80) (92) (100) 가  
 20mm 6.00mm ± 0.25mm (80) LTO 14mm ( 8 )  
 ) (52) (58)  
 (80) (98) , 가 LTO 가  
 (52) (98) , 가  
 (80)  
 13 (12) (w2) (12) (80) (92)  
 (12) (98)( ) (12)  
 (94,96) (98) (52)  
 (w2) ( 4 )  
 (12) (80)  
 LTO 67mm (w2) LTO  
 , 77mm가 (bezeled corner surface)(102) LTO  
 (80)  
 LTO LTO (80)( 13) (104) LTO  
 (60,62)  
 0.08 mm 가 (60) 가 5 mm (80)  
 3.00mm ± 0.08mm (62) 가 5mm (60) 20.50mm ± 0.20mm  
 (96) 9.60mm (60,62)가 (94) 4.8mm ,  
 가 LTO (98) 13.25mm  
 14 , LTO V (68)가 5.05mm  
 , V (68) 가 8.90mm (68) V  
 1.50mm (68,62) (68)  
 LTO 60° ± 1° (68) (62) (68)  
 4.20mm [ (96) 13.80mm (62) ]  
 , (60,62,68) (36) (80)가 LTO  
 가 (36) 51.00mm ,  
 55.70 mm 가 (80)  
 LTO (receiving slot)  
 LTO 3.6 mm 가 ,  
 ( 1 ) 가  
 (leader block assembly)  
 0) LTO (leader pin assembly) ( , ) (8  
 0924701 , 0924702 , 0924703 , 0926675 ,  
 0926676 ) . 17 18 (110)  
 (112) 가 (90) LTO  
 / LTO  
 가 가 (retaining notch)(114)  
 (96) (spring-loaded pin)



- 5 . ,
11. 5 . ,
12. 7 . ,
13. 7 . ,
14. 1 . , LTO 1 2 , V
- 1 가 5mm , 3.00mm ± 0.08mm , 20.50mm ± 0.20mm ,
- 2 가 5mm , 4.8mm , 3.0 0mm ± 0.08mm 86.15mm ± 0.25mm , 20.50mm ± 0.20mm 1
- V 가 가 8.90mm , 5.05mm 1.50mm , V 60° ± 1° .
15. 14 1 2 가, 9.60mm . 13.25mm
16. 14 , V 13.80mm .
17. 15 , V 13.80mm .
18. 15 , 51.00mm 55.70mm 가 , .
19. 17 , 51.00mm 55.70mm 가 , .
20. 14 , 가 1.8mm , , 가 8.70mm , 14mm 20mm 6.00mm , 가 4.75mm .

20 21.

21 22.

67mm

21 23.

14 24.

14 25.

19 26.

가

1.8mm

20mm 6.00mm 가

가

4.75mm

8.70mm

14mm

26 27.

27 28.

67mm

27 29.

29 30.

29 31.



1

(종래 기술)

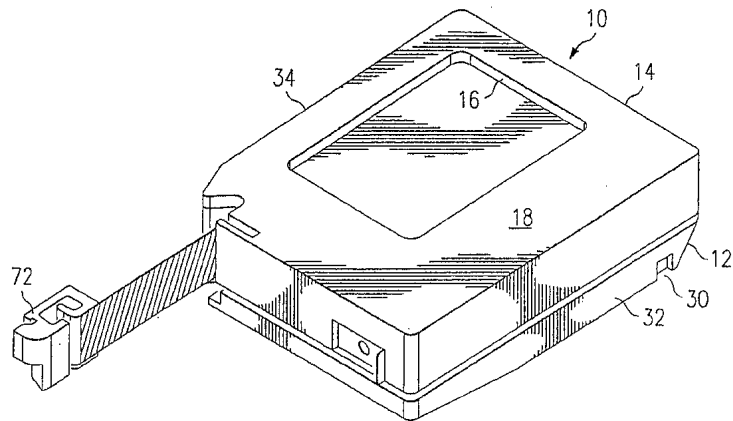

2

(종래 기술)

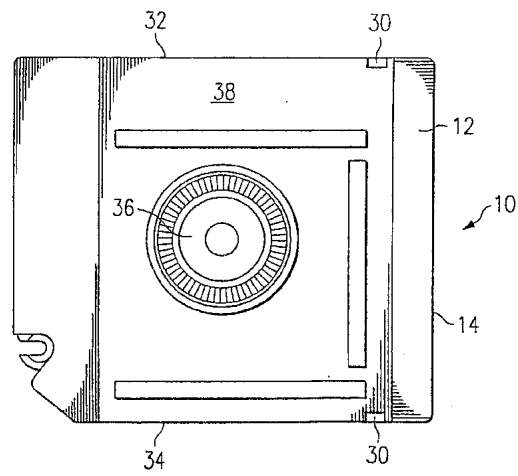

3

(종래 기술)

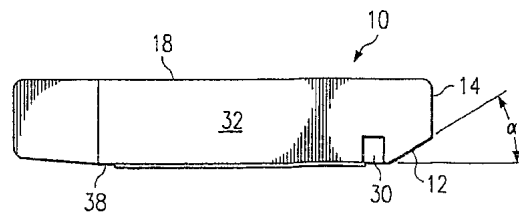

4

(종래 기술)

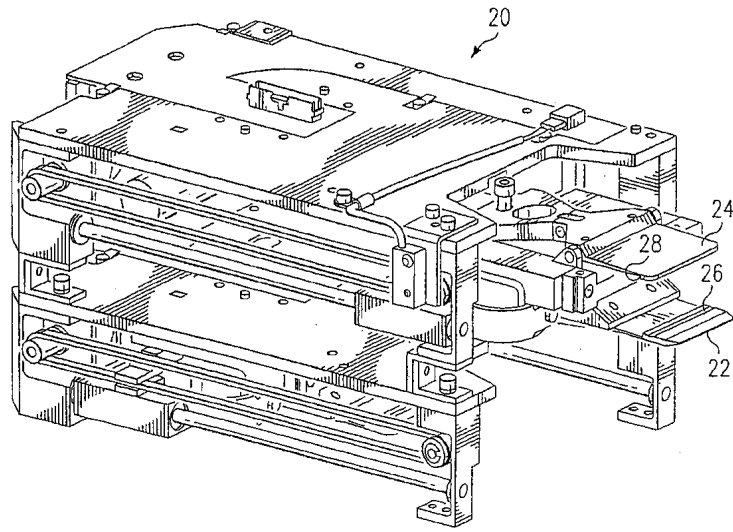

5

(종래 기술)

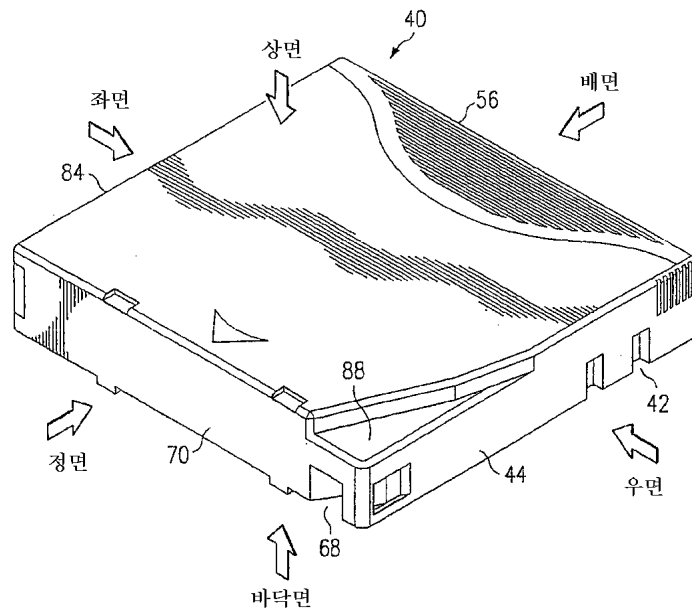

6

(종래 기술)

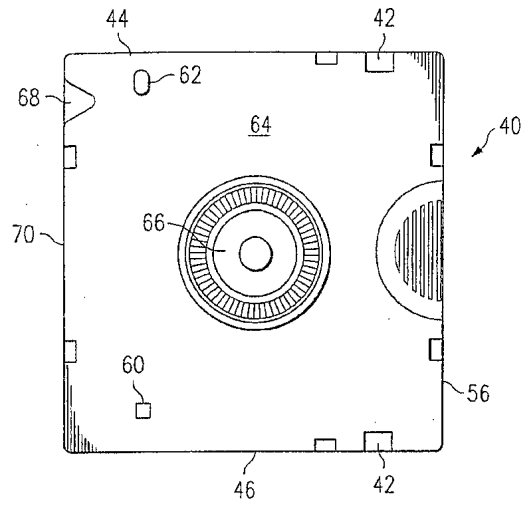

7

(종래 기술)

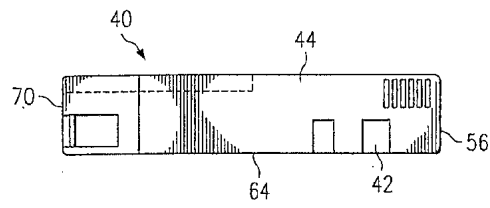

8

(종래 기술)

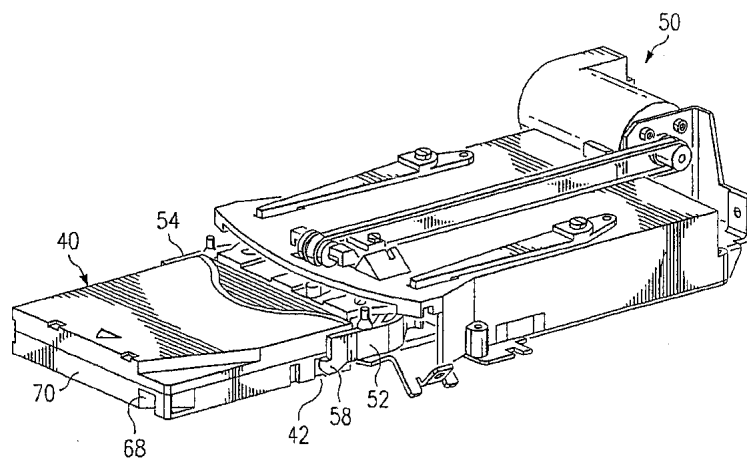

9

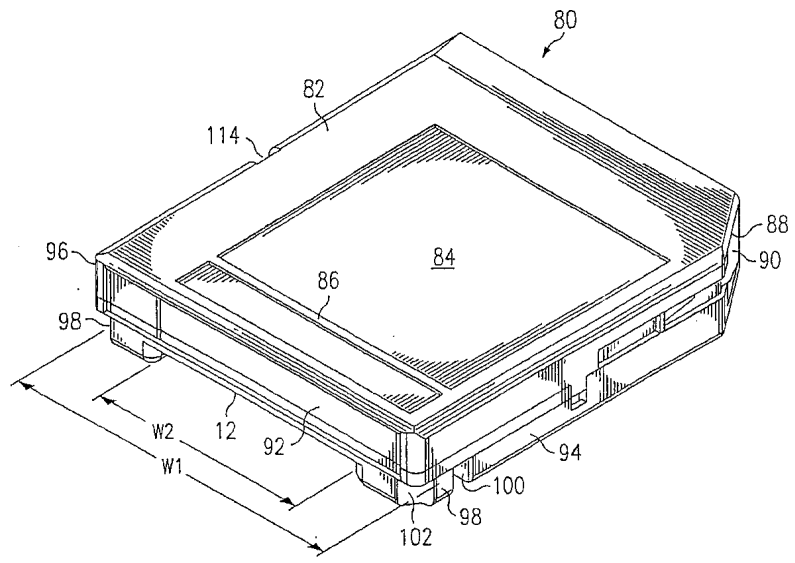

10

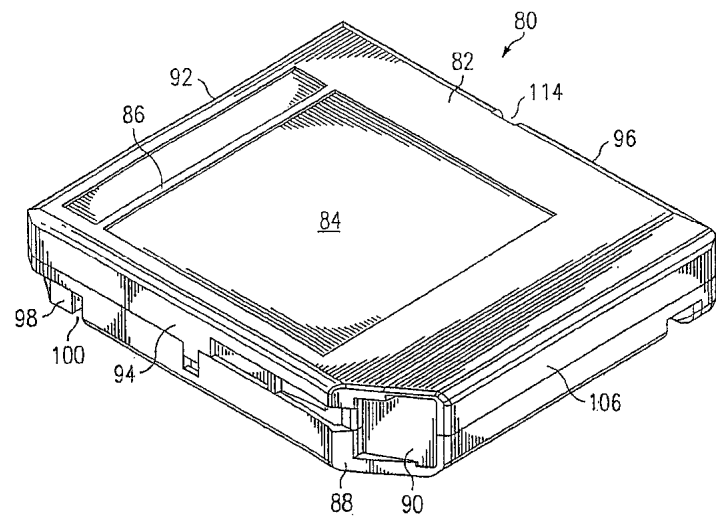

11

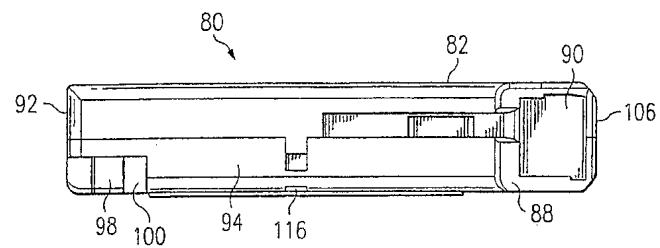

12

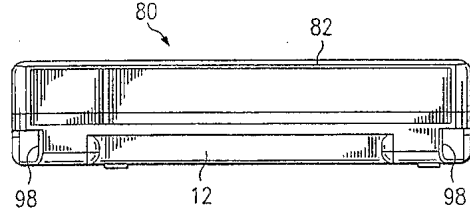

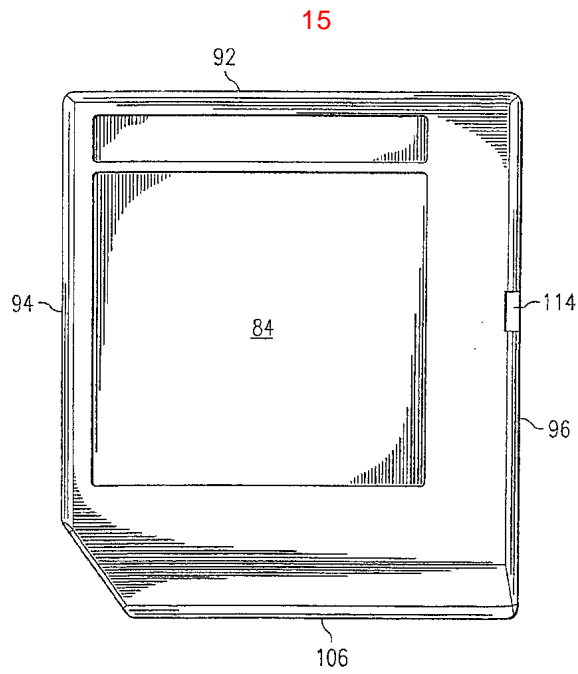
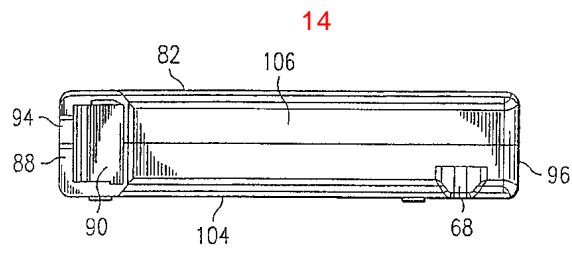
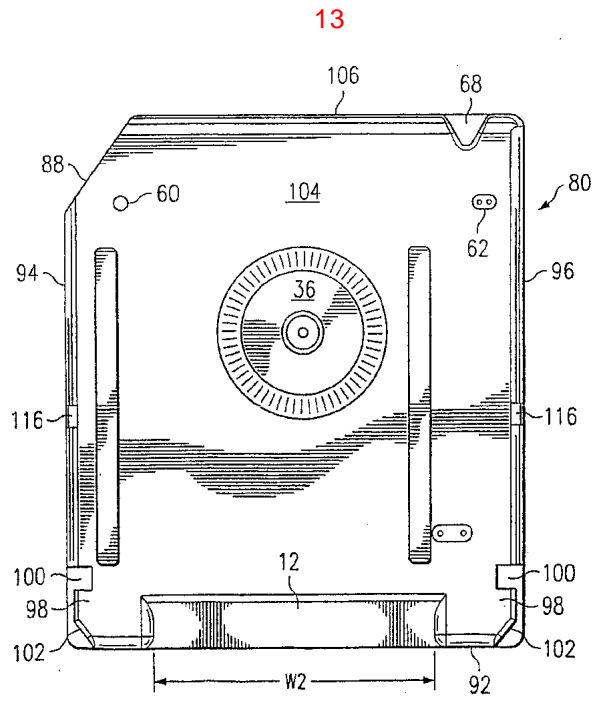

16

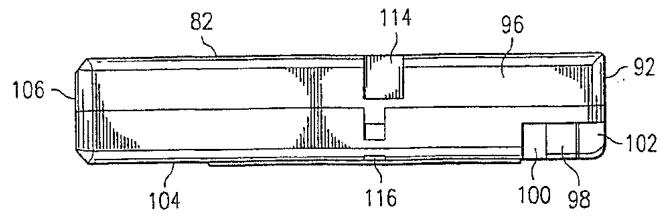

17

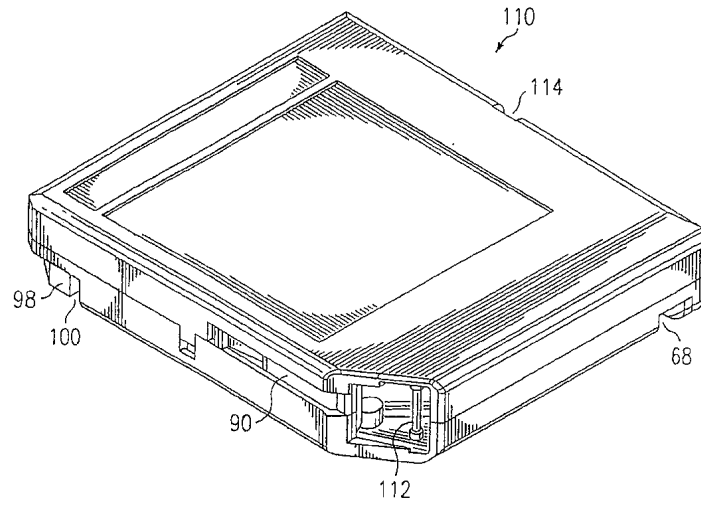

18

