

(19) World Intellectual Property Organization
International Bureau



(43) International Publication Date
30 March 2006 (30.03.2006)

PCT

(10) International Publication Number
WO 2006/034245 A2

(51) International Patent Classification:
A61B 17/00 (2006.01)

(21) International Application Number:

PCT/US2005/033593

(22) International Filing Date:

20 September 2005 (20.09.2005)

(25) Filing Language:

English

(26) Publication Language:

English

(30) Priority Data:

10/946,332 20 September 2004 (20.09.2004) US
10/945,855 20 September 2004 (20.09.2004) US

(71) Applicant (for all designated States except US): **CARDIAC DIMENSIONS, INC.** [US/US]; 5540 Lake Washington Blvd. NE, Kirkland, WA 98033 (US).

(72) Inventors; and

(75) Inventors/Applicants (for US only): **GORDON, Lucas, S.** [US/US]; 23420 Black Nuggett Road NE, # E201, Issaquah, WA 98029 (US). **MATHIS, Mark, L.** [US/US]; 44619 Parkmeadow Drive, Fremont, CA 94539 (US). **NIEMINEN, Gregory** [US/US]; 23017 - 12th Drive SE, Bothell, WA 98021 (US). **KOWALSKY, Leonard** [US/US]; 1403 243rd Place SE, Bothell, WA 98021 (US). **BRAXTON, Ryan** [US/US]; 7896 Maple Avenue SE, Snoquamine, WA 98065 (US). **DOLL, Brian, J.** [US/US]; 2216 - 226th Place NE, Sammamish, WA 98074 (US).

(74) Agents: **SKUBATCH, Maya** et al.; Wilson Sonsini Goodrich & Rosati, 650 Page Mill Road, Palo Alto, CA 94304-1050 (US).

(81) Designated States (unless otherwise indicated, for every kind of national protection available): AE, AG, AL, AM, AT, AU, AZ, BA, BB, BG, BR, BW, BY, BZ, CA, CH, CN, CO, CR, CU, CZ, DE, DK, DM, DZ, EC, EE, EG, ES, FI, GB, GD, GE, GH, GM, HR, HU, ID, IL, IN, IS, JP, KE, KG, KM, KP, KR, KZ, LC, LK, LR, LS, LT, LU, LV, LY, MA, MD, MG, MK, MN, MW, MX, MZ, NA, NG, NI, NO, NZ, OM, PG, PH, PL, PT, RO, RU, SC, SD, SE, SG, SK, SL, SM, SY, TJ, TM, TN, TR, TT, TZ, UA, UG, US, UZ, VC, VN, YU, ZA, ZM, ZW.

(84) Designated States (unless otherwise indicated, for every kind of regional protection available): ARIPO (BW, GH, GM, KE, LS, MW, MZ, NA, SD, SL, SZ, TZ, UG, ZM, ZW), Eurasian (AM, AZ, BY, KG, KZ, MD, RU, TJ, TM), European (AT, BE, BG, CH, CY, CZ, DE, DK, EE, ES, FI, FR, GB, GR, HU, IE, IS, IT, LT, LU, LV, MC, NL, PL, PT, RO, SE, SI, SK, TR), OAPI (BF, BJ, CF, CG, CI, CM, GA, GN, GQ, GW, ML, MR, NE, SN, TD, TG).

Published:

— without international search report and to be republished upon receipt of that report

For two-letter codes and other abbreviations, refer to the "Guidance Notes on Codes and Abbreviations" appearing at the beginning of each regular issue of the PCT Gazette.

(54) Title: PERCUTANEOUS MITRAL VALVE ANNULOPLASTY DELIVERY SYSTEM

(57) Abstract: The invention is a tissue shaping system, including a tissue shaping device with an expandable anchor and a lock; a delivery catheter; a delivery mechanism adapted to deliver the tissue shaping device from outside a patient to a target site within a lumen within the patient via the delivery catheter; and an actuator adapted to deliver an actuation force to the lock to lock the anchor in an expanded configuration. The invention is also a system adapted to percutaneously deliver and deploy a tissue shaping device at a target site within a lumen of a patient. The system includes: a handle; a delivery mechanism supported by the handle and adapted to deliver the tissue shaping device from outside the patient to the treatment site via a delivery catheter; and an actuator supported by the handle and adapted to deliver an actuation force to lock an anchor of the tissue shaping device in an expanded configuration.

WO 2006/034245 A2

PERCUTANEOUS MITRAL VALVE ANNULOPLASTY DELIVERY SYSTEM

BACKGROUND OF THE INVENTION

The invention relates generally to percutaneous delivery systems for tissue shaping devices intended to be delivered through a lumen to a site within a vessel of the patient to modify target tissue adjacent to the vessel. In particular, the invention relates to delivery systems for percutaneous mitral valve annuloplasty devices and methods for using the same.

Tissue shaping devices for treating mitral valve regurgitation have been described. See, e.g., U.S. Patent Appl. S.N. 10/142,637, "Body Lumen Device Anchor, Device and Assembly;" U.S. Patent Appl. S.N. 10/331,143, "System and Method to Effect the Mitral Valve Annulus of a Heart;" U.S. Patent Appl. S.N. 10/429,172, "Device and Method for Modifying the Shape of a Body Organ;" and U.S. Patent Appl. S.N. 10/742, 516, "Tissue Shaping Device With Conformable Anchors." These devices are intended to be delivered percutaneously to a site within a patient's coronary sinus and deployed to reshape the mitral valve annulus adjacent to the coronary sinus.

During deployment of such tissue shaping devices one or more anchors may need to be expanded and locked using actuation forces delivered from outside the patient. Thus, the percutaneous delivery and deployment of tissue shaping devices may require the physician to perform remote operations on the device and on the patient through the device. What is needed, therefore, is a delivery system that permits the physician to perform these tasks.

SUMMARY OF THE INVENTION

The present invention provides a tissue shaping delivery system and method. One aspect of the invention is a tissue shaping system including a tissue shaping device with an expandable anchor and a lock; a delivery catheter; a delivery mechanism (including, e.g., a pusher) adapted to deliver the tissue shaping device from outside a patient to a target site within a lumen within the patient via the delivery catheter; and an actuator adapted to deliver an actuation force to the lock to lock the anchor in an expanded configuration. In some embodiments, the invention includes a cartridge adapted to contain the tissue shaping device, the delivery mechanism being further adapted to deliver the tissue shaping device from the cartridge to the delivery catheter. The tissue shaping system may also include a dye port adapted to admit an imaging contrast agent to the lumen, such as during delivery and deployment of the tissue shaping device. The dye port may be part of a connector extending from a proximal end of the delivery catheter, with the connector also including a device port, the delivery mechanism being further adapted to delivery the tissue shaping device from outside the patient to the delivery catheter through the device port.

In some embodiments the tissue shaping system includes a handle associated with the delivery mechanism. The handle may be adapted to support the actuator. In embodiments in which the system includes a cartridge adapted to contain the tissue shaping device, the cartridge may be further adapted to engage the handle during delivery and/or deployment of the tissue shaping device.

In some embodiments of the tissue shaping system, the actuator is further adapted to operate the delivery mechanism to move the tissue shaping device with respect to the delivery catheter to, e.g., expose or recapture the anchor. In some embodiments, the actuator is a rotating nut.

In some embodiments of this aspect of the invention the actuator is adapted to move the delivery catheter distally to lock the anchor. In other embodiments the tissue shaping system may also include a locking sleeve, the actuator being further adapted to move the locking sleeve distally to lock the anchor.

In some embodiments the tissue shaping system includes an attachment mechanism adapted to attach the tissue shaping device to the delivery mechanism, such as a tether attached to the tissue shaping device. The attachment mechanism may be further adapted to release the tissue shaping device from the delivery mechanism, such as through the use of a hitch wire and a tether attached to the tissue shaping device. The attachment mechanism may also include a hitch wire actuator adapted to move the hitch wire to release the tether from the device and/or a device release interlock adapted to prevent release of the device prior to actuating the anchor lock actuator.

In some embodiments of the tissue shaping system, the tissue shaping device further includes a second anchor, the actuator being further adapted to deliver an actuation force to a second anchor lock to lock the second anchor in an expanded configuration. The system may alternatively have a second actuator, the second actuator being further adapted to deliver an actuation force to the second anchor lock to lock the second anchor in an expanded configuration. A handle may support the first and second actuators.

Another aspect of the invention provides a system adapted to percutaneously deliver and deploy a tissue shaping device at a target site within a lumen of a patient, including : a handle; a delivery mechanism (possibly including a pusher) supported by the handle and adapted to deliver the tissue shaping device from outside the patient to the treatment site via a delivery catheter; and an actuator supported by the handle and adapted to deliver an actuation force to lock an anchor of the tissue shaping device in an expanded configuration. In some embodiments the handle has a cartridge interface adapted to mate with a cartridge containing a tissue shaping device, and the delivery system may be further adapted to deliver the tissue shaping device from a delivery catheter to the target site when a tissue shaping device cartridge engages the cartridge interface. In some embodiments, the actuator may include the cartridge interface. In some embodiments the actuator may include a rotating member with threads adapted to mate with threads on a cartridge.

In some embodiments the system includes a locking sleeve, the actuator being further adapted to move the locking sleeve distally to lock the anchor. The handle may include a channel, with the actuator being disposed in the channel, and the actuator may include an actuator lock adapted to prevent movement of the actuator within the channel.

In some embodiments the system includes a device attachment mechanism supported by the handle and adapted to attach the tissue shaping device to the handle. The attachment mechanism may include a tether attached to the handle and/or a hitch wire attached to the handle. In embodiments with a hitch wire the attachment mechanism further may a hitch wire actuator adapted to move the hitch wire to release the device and possibly a device release interlock adapted to prevent operation of the hitch wire actuator prior to actuating the anchor lock actuator.

INCORPORATION BY REFERENCE

All publications and patent applications mentioned in this specification are herein incorporated by reference to the same extent as if each individual publication or patent application was specifically and individually indicated to be incorporated by reference.

BRIEF DESCRIPTION OF THE DRAWINGS

The novel features of the invention are set forth with particularity in the appended claims. A better understanding of the features and advantages of the present invention will be obtained by reference to the following detailed description that sets forth illustrative embodiments, in which the principles of the invention are utilized, and the accompanying drawings of which:

Figure 1 is a cross-sectional view of a human heart showing a tissue shaping device in the lumen of the coronary sinus.

Figure 2 is a schematic view of a tissue shaping device delivery system according to this invention.

Figure 3 is a cross-sectional view showing a step in the delivery and deployment of a tissue shaping device according to this invention.

Figure 4 is a cross-sectional view showing another step in the delivery and deployment of a tissue shaping device according to this invention.

Figure 5 is a cross-sectional view showing another step in the delivery and deployment of a tissue shaping device according to this invention.

Figure 6 is a cross-sectional view showing another step in the delivery and deployment of a tissue shaping device according to this invention.

Figure 7 is a cross-sectional view showing a step in the recapture of a tissue shaping device according to this invention.

Figure 8 is a cross-sectional view showing a step in the recapture of a tissue shaping device according to this invention.

Figure 9 shows an attachment mechanism for a tissue shaping device delivery system.

Figure 10 shows another attachment mechanism for a tissue shaping device delivery system.

Figure 11 shows yet another attachment mechanism for a tissue shaping device delivery system.

Figure 12 shows still another attachment mechanism for a tissue shaping device delivery system.

Figure 13 is a detail of the attachment mechanism of Figure 12 in a disengaged configuration.

Figure 14 is a perspective view of a tissue shaping device delivery system according to this invention.

Figure 15 is another perspective view of the tissue shaping device delivery system of Figure 14 showing a tissue shaping device without a cartridge.

Figure 16 is an exploded view of the tissue shaping device and delivery system of Figure 15.

Figure 17 is a partial cross-sectional view of certain portions of the tissue shaping device delivery system of Figure 15.

Figure 18 is a detailed cross-sectional view of a portion of the tissue shaping device shown in Figure 17.

Figure 19 is a perspective view of a cartridge for the tissue shaping device delivery system of Figure 14.

Figure 20 is a cross-sectional view of the cartridge of Figure 19.

Figure 21 is a cross-sectional view of a delivery catheter and connector for use with the tissue shaping device delivery system of Figures 14-20.

DETAILED DESCRIPTION OF THE INVENTION

While the invention relates to methods and devices for delivering tissue shaping devices generally, the invention will be described with respect to tissue shaping devices delivered to the coronary sinus of the heart to reshape the mitral valve annulus to treat mitral valve regurgitation. As used herein, "coronary sinus" includes the great cardiac vein as well as the coronary sinus of the heart.

Figure 1 shows a cross-section of a human heart 10 with the atria removed to show the mitral valve 12, the mitral valve annulus 14 and the coronary sinus 16. A tissue shaping device 20 in the form of a percutaneous mitral valve annuloplasty device is disposed within the coronary sinus to reshape the mitral valve annulus 14 to provide for improved coaptation of the mitral valve leaflets. As shown, tissue shaping device 20 has an expandable distal anchor 22, a distal anchor lock 24, an expandable proximal anchor 26, a proximal anchor lock 28, and a connector 30 extending between the distal and proximal anchors. Proximal anchor lock 28 has serves as a delivery system attachment mechanism, as explained below.

Figure 2 is a schematic drawing showing the general elements of a delivery system 40 adapted to delivering and deploying a tissue shaping device to a target site within the lumen of a vessel in or around a patient's heart 42. A delivery catheter 44 has been inserted through an opening 46 formed in the patient's jugular vein or other blood vessel and advanced into the heart. Delivery system 40 interacts with delivery catheter 44 to deliver and deploy the tissue shaping device at the target site within the patient.

Figures 3-6 show steps from the delivery and deployment of a tissue shaping device having at least one anchor similar to the anchors of device 20 of Figure 1. In Figure 3, a tissue shaping device 50 has been delivered to a target site within the lumen of a vessel 54 via a delivery catheter 56. Figure 3 shows an expandable anchor 52 of tissue shaping device 50 beginning to emerge from catheter 56. In this embodiment, this action is due to proximal movement of catheter 56 while device 50 is held stationary. In alternative embodiments, the device could be delivered from the distal end of the catheter by pushing the device distally while holding the catheter stationary or a combination of distal movement of the device and proximal movement of the catheter. Anchor 52 is shown in a collapsed, unexpanded configuration.

A delivery system 70 provides the mechanisms to deliver and deploy device 50 from outside the patient. Actuator 72 and delivery mechanism 74 associated with catheter 56 and device 50, respectively, provide for the relative movement between device 50 and catheter 56. For example, delivery mechanism 74 may be a pusher used to advance device 50 down catheter 56 to the target site shown in Figure 3, and actuator 72 can be used to pull catheter 56 proximally while delivery mechanism 74 holds device 50 stationary within vessel 54. Actuator 72 and delivery mechanism 74 may be supported by a handle or other housing 76.

In Figure 4, catheter 56 has been pulled further proximally by actuator 72 so that anchor 52 is completely outside of catheter 56 and has started to self-expand. In this embodiment, anchor 52 is formed from a shape memory material (such as Nitinol) and has been treated so as to expand upon emergence from the catheter.

Figures 5 and 6 show how the delivery system may be used to further expand and lock anchor 52. Formed in the proximal side 58 of anchor 52 is a loop 60 encircling a proximally extending connector 62. Connector 62 may connect with other elements at the proximal side of device 50, such as a second anchor, depending on device design. As shown in Figure 5, while delivery mechanism 74 holds device 50 stationary,

actuator 72 has moved delivery catheter 56 distally to engage the proximal side 58 of anchor 52 and to move it distally to further expand anchor 52.

As shown in Figure 6, further distal movement of delivery catheter 56 with respect to device 50 has pushed loop 60 distally over a lock bump 64. Lock bump 64 cams inward in response to the distal force of loop 60, then returns to its prior shape to hold loop 60 distal to lock bump 64. Delivery catheter may then be moved proximally to perform other functions or to be removed from the patient.

After deployment of a tissue shaping device, it may become necessary to reposition the device or to remove the device from the patient. Figures 7 and 8 demonstrate the recapture of tissue shaping device 50 back into delivery catheter 56 after delivery and deployment.

In Figure 7, delivery mechanism 74 holds device 50 stationary while delivery catheter 56 is advanced distally against anchor 52 by actuator 72. The actuation force against anchor 52 collapses the anchor, allowing delivery catheter to recapture the device as shown in Figure 8. The catheter and device can then be removed from the patient or moved to another target site.

Figure 9 shows an attachment mechanism between a tissue shaping device 80 and a delivery mechanism, such as pusher 82, within a delivery catheter 84. Pusher extends outside of the patient and is attached to a handle or other housing 86, such as through an actuator. Pusher 82 may be operated by an actuator or by the handle itself to advance device 80 distally through catheter 84 or to hold device 80 stationary against a proximal force exerted on device 80, such as when delivery catheter 84 is withdrawn proximally by an actuator 88.

Device 80 has an attachment eyelet 90. A tether 92 extending down pusher 82 has a loop 94 formed at its distal end. The proximal ends of tether 92 are preferably attached to handle 86. Loop 94 extends through eyelet 90, and a hitch wire 96 passes through loop 94 and into the proximal end of device 80 as shown, thereby preventing loop 94 from being withdrawn from eyelet 90. Tether 92 can be used to pull device 80 proximally or to hold device 80 stationary against a distal force exerted on device 80, such as during recapture. Tether 92 may also be used to hold device 80 tightly against pusher 82 during delivery and deployment of the device.

To release device 80 from the delivery mechanism, hitch wire 96 may be disengaged from device 80. In this embodiment, hitch wire 96 is disengaged by moving the hitch wire proximally through the action of a hitch wire actuator 98 while holding device 80 stationary with pusher 92. When hitch wire 96 is disengaged from device 80 and moved proximal to the loop of tether 92, proximal movement of tether 92 will pull the tether's loop out of eyelet 90.

Figure 10 shows another attachment mechanism for a tissue shaping device and its delivery mechanism. As in the embodiment of Figure 9, an eyelet 102 extends proximally from tissue shaping device 100 within delivery catheter 104. The distal end of pusher 106 has an eyelet 108 at its distal end that overlaps with device eyelet 102 to form an overlap opening 110. A hitch wire 112 extends through pusher 106 and overlap opening 110 into the proximal end of tissue shaping device 100.

As in the previous embodiment, catheter 104, pusher 106 and hitch wire 112 extend out of the patient to a handle or other housing 114. Pusher 106 may be operated by an actuator or by handle 114 to advance device 100 distally through catheter 104 or to hold device 100 stationary against a proximal force exerted on device 100, such as when delivery catheter 104 is withdrawn proximally by an actuator 116 supported by handle 114. Also, because the attachment mechanism of this embodiment holds pusher 106 against device 100, pusher

106 can be used to pull device 100 proximally or to hold device 100 stationary against a distal force exerted on device 100, such as during recapture.

To release device 100 from the delivery mechanism, hitch wire 112 may be disengaged from device 100. As in the embodiment of Figure 9, hitch wire 112 is disengaged by moving the hitch wire proximally through the action of a hitch wire actuator 118 while holding device 100 stationary with pusher 106. When hitch wire 112 is disengaged from device 100 and moved proximal to the overlap opening 110, device 100 is disengaged from the delivery mechanism.

Figure 11 shows an attachment mechanism that can be used to engage a tissue shaping device after initial deployment for possible recapture of the device. As in other embodiments, device 120 has a proximal eyelet 122. Retractor 124 has a cable 126 extending through it. Cable 126 has a loop 128 at its distal end and free ends 130 extending out of the patient, possibly to a handle or housing (not shown). To engage device 120, retractor 124 and looped cable 126 are advanced to device 120 with loop 128 arranged to be large enough to surround eyelet 122. When loop 128 passes over and around eyelet 122, one or both of the free ends of cable 126 are pulled proximally to pull loop 128 tightly about eyelet 122, as shown. Retractor 124 may then be used to pull device 120 proximally, such as for recapture into a catheter. Alternatively, retractor may be used as a pusher to apply a distally directed force on device 120, if needed.

Figures 12 and 13 show yet another attachment mechanism between a tissue shaping device and a delivery mechanism. Tissue shaping device 140 has a locking structure 142 at its proximal end designed to mate with a corresponding locking structure 144 at the distal end of a pusher 146 within catheter 148. A cover 150 is disposed over the interlocked locking structures to maintain the connection between device 140 and pusher 146. A tether 152 is connected to cover 150.

Catheter 148, pusher 146 and tether 152 extend out of the patient to a handle or other housing 154. Pusher 146 may be operated by an actuator or by handle 154 to advance device 140 distally through catheter 148 or to hold device 140 stationary against a proximal force exerted on device 140, such as when delivery catheter 148 is withdrawn proximally by an actuator 156 supported by handle 154. Also, because the attachment mechanism of this embodiment holds pusher 146 against device 140, pusher 146 can be used to pull device 140 proximally or to hold device 140 stationary against a distal force exerted on device 140, such as during recapture.

To release device 140 from the delivery mechanism, tether 152 may be pulled proximally to pull cover 150 off of the locking structures 142 and 144, such as by use of an actuator 158, while holding device 100 stationary with pusher 146. Locking structures 142 and 144 are preferably formed from a shape memory material. When cover 150 is removed from the locking structures, the locking structures assume an unstressed configuration such as that shown in Figure 13, thereby disengaging device 140 from pusher 146.

Figures 14-21 show a tissue shaping device delivery and deployment system according to one embodiment of this invention. The system includes a handle 200 supporting delivery, deployment and attachment mechanisms for a tissue shaping device 202 having distal and proximal expandable anchors 204 and 206, respectively. In Figure 14, the device is disposed in a compressed configuration within a cartridge 208. In this embodiment, the device will go directly from cartridge 208 into a delivery catheter for delivery and deployment in a patient.

As shown in Figure 15, a pusher 210 abuts the proximal end of tissue shaping device 202. Pusher 210 should be flexible and incompressible, and its properties may vary from section to section along its length. In one embodiment, pusher 210 is formed at its distal end from a coiled spring 212 (e.g., to facilitate bending) and thereafter from a stainless steel hypotube 214. Device 202 is attached to pusher 210 via a tether 216 and hitch wire 218 in an arrangement such as that described above with respect to Figure 9. The tether has to be strong enough to apply an appropriate proximally directed force during delivery, deployment and recapture; the hitch wire has to be stiff enough not to kink or pull through the eyelet when the tether is pulled proximally. For example, for use in a tissue shaping system intended to treat mitral valve regurgitation via the coronary sinus, the tether preferably can pull up to 18 pounds. In one embodiment, tether 216 is formed from .007 inch stainless steel with a full hard temper, and hitch wire is formed from .011 inch 304 stainless steel. Tether 216 and hitch wire 218 extend through the pusher's lumen. Pusher 210, tether 216 and hitch wire 218 are attached to and supported by handle 200, as discussed below with respect to Figures 17 and 18.

Surrounding pusher 210 is a locking sleeve 220 whose inner diameter is close to the outer diameter of pusher 210 in order to minimize backflow of blood or other fluids. The proximal end of locking sleeve 220 is supported by a slider (not shown) resting in a circular track formed by the handle housing. Actuator knobs 222 are threaded into holes formed in the sides of the slider, and the slider and actuator knobs are attached to the locking sleeve 220 by adhesive. One of the actuator knobs may be provided with an actuation interlock, such as a screw down portion 223 that screws against the handle housing to prevent movement of the actuator knobs and locking sleeve. As shown in Figure 16, actuator knobs 222 fit in tracks 224 formed in handle 200.

When assembling the delivery system, pusher 210 is placed within locking sleeve 220. Handle housing 226 has two parts, 228 and 230, which are placed and screwed together around the locking sleeve and pusher. As shown in Figure 18, assembly of the two halves of handle housing 226 attaches the proximal end of pusher 210 to handle 200 with a press fit connection (which may be supplemented with adhesive) in a pusher connection area 232 of handle housing 226. Locking sleeve actuator knobs 222 are in the tracks 224, as discussed above.

Hitch wire 218 and tether 216 are then threaded into the central lumen of pusher 210, and device 202 is attached by placing the looped end of tether 216 through an eyelet (not shown) on the proximal end of device 202. Hitch wire 218 passes through the looped end of tether 216 into the device's proximal anchor crimp tube 207. (Placement of the distal end of the hitch wire inside the crimp tube helps prevent injury to the patient's heart or blood vessels by the hitch wire.)

Tether 216 and hitch wire 218 extend proximally from the proximal end of pusher 210 through the proximal end of pusher connection area 232 and through holes formed in a disc 236 disposed proximal to pusher connection area 232 and jack nut 234. A crimp tube 238 or other connector attaches to the proximal end of tether 216 to prevent it from passing distally through disc 236; excess portions of tether 216 may be cut off. A jack nut 234 threaded around the outside of pusher connection area 232 may then be rotated about pusher connection area 232 to move jack nut 234, disc 236 and crimp tube 238 proximally with respect to the handle housing, thereby tightening tether 216 and pulling device 202 tight against pusher 210.

A release knob 240 is threaded onto handle housing 226 around pusher connection area 232 with track portions 242 lining up with handle tracks 224, as shown. Hitch wire 218 extends proximally through release knob 240 and a second disc 244, and the proximal end of hitch wire 218 is crimped with one or more crimp

tubes 246 to prevent distal movement of hitch wire 218 with respect to the handle. A cap 248 covers the distal end of hitch wire 218 to prevent injury to the user from the sharp wire end.

Prior to delivery and deployment, the eyelet of the proximal anchor 206 is pulled proximally over the pusher coil 212, and the eyelet of the distal anchor is pulled proximally over the connector between the two anchors. Device 202 is then compressed and loaded into cartridge 208 with the distal anchor 204 at the distal end of the cartridge and with the pusher, tether and hitch wire extending from the proximal end of cartridge 208 into handle 200. A loading tool, such as a two-piece funnel, may be used to assist in the compression and loading of the device into the cartridge. In a preferred embodiment, a control nut 250 is threaded onto the threaded exterior of cartridge 208, as shown in Figure 14.

Cartridge 208 is shown in more detail in Figures 19 and 20. Cartridge 208 has a central lumen 252 with a lubricious polymeric liner. The diameter of central lumen 252 may be substantially the same as the diameter of a delivery catheter to be used to deliver device 202. Alternatively, the diameter of central lumen 252 may be larger than the intended delivery catheter diameter to minimize stress on the tissue shaping device during sterilization, temperature changes during shipping, etc. Cartridge 208 has a male luer connector 254 at its distal end for mating with a corresponding female luer connector on the delivery catheter, as described below. The outside of the cartridge preferably has at least one flat side in order to prevent rotation of the cartridge with respect to the handle during deployment, as described below. In the embodiment shown in Figures 19 and 20, cartridge 208 has a hexagonal cross-section presenting six possible orientations for mating with a flat side formed on the inside of the handle during delivery and deployment of the tissue shaping device. An O-ring seal 255 at the proximal end of cartridge 208 seals around locking sleeve 220 to prevent backflow of blood or other fluids while still permitting relative movement between locking sleeve 220 and cartridge 208.

Figure 21 shows a delivery catheter 260 and connector 262 for use with the cartridge and handle of this invention. The length and diameter of catheter 260 depends on the application. For example, to deliver a tissue shaping device to the coronary sinus through the jugular vein to treat mitral valve regurgitation, catheter 260 may be a nine french diameter catheter at least 65 cm. long. Catheter 260 may also have a radiopaque marker on its distal end for visualization via fluoroscopy. When it needs to negotiate bends and turns to reach the target treatment site, catheter 260 may be more flexible at its distal tip than along its proximal end. Catheter 260 may also be braided to increase its compression strength, which aids in locking anchors, recapturing devices, etc., as described below.

Y-shaped connector 262 is attached to the proximal end of catheter 260 by adhesive and a shrink tube 264. Connector 262 has a main channel 266 with a female luer connection 268 adapted to mate with the luer connection of cartridge 208. A second channel 270 meets the main channel 266 proximal to the proximal end of delivery catheter 260. Second channel 270 also has a luer connection to permit it to be connected to a source of imaging contrast agent, such as dye. Second channel 270 enables a dye source to be connected and for dye to be injected even during use of the main channel to deliver and deploy the tissue shaping device. (The space between the inner diameter of the delivery catheter and the outer diameter of the locking sleeve permits contrast dye to flow distally to the target treatment site.) A cap 272 may be used to close off second channel 270 when not in use. The diameters of both channels transition down from the standard luer fitting size to the diameter of the delivery catheter.

A first step for using the tissue shaping system of this invention to treat mitral valve regurgitation is to access the coronary sinus of the patient's heart. One way of reaching the coronary sinus is to insert a sheath into the patient's jugular vein. A guide catheter with a precurved tip may then be inserted into the sheath and advanced to coronary sinus ostium within the right atrium of the heart. A guidewire may then be advanced through the guide catheter and into the coronary sinus, and the guide catheter may be removed from the patient, leaving the guidewire behind. The delivery catheter 260 may then be advanced along the guidewire, and the guidewire may be removed.

The anatomy of the heart varies from patient to patient. For example, the diameter and length of the coronary sinus are patient-dependent as well as the location of coronaries arteries that may pass between the coronary sinus and the heart. One optional method step, therefore, is to introduce dye or another imaging contrast agent into the coronary sinus through the delivery catheter (such as through the Y-shaped connector 262) to perform a venogram while performing an angiogram on the coronary arteries in a known manner. These images will identify the relative positions of the coronary sinus and coronary arteries and will give a relative indication of the length and diameter of the coronary sinus at the target treatment site.

In addition, in order to calibrate the venogram with the actual size of the imaged vessels, a marker catheter may be inserted into the coronary sinus through the delivery catheter during the venogram. The marker catheter has radiopaque markings a fixed distance apart. By measuring on the venogram the distance between markings on the marker catheter, a correction factor may be devised to correct the measured diameter and length of the coronary sinus. Alternatively, radiopaque markings may be added to the delivery catheter itself, thereby eliminating the need to insert a marker catheter to obtain the correction factor measurements. Dye may also be injected during delivery and deployment of the tissue shaping device for imaging purposes.

After removal of the marker catheter, the delivery system may be attached to the delivery catheter. Prior to the start of the procedure, locking sleeve 220 is in its proximal-most position so that locking sleeve actuator knobs 222 are in slots 242 of release knob 240, and screw down portion 223 is screwed against housing 226 to hold locking sleeve 220 in place. Pusher 210 and locking sleeve 220 extend from the distal end of handle 200 to the device 202 within cartridge 208. The lengths of pusher 210 and locking sleeve 220 correspond to the length of delivery catheter 260, as discussed below. Lengths of pusher 210 and locking sleeve 220 may be exposed between handle 200 and cartridge 208.

To begin delivering tissue shaping device 202 to the patient's coronary sinus, cartridge 208 (containing tissue shaping device 202) and delivery catheter 260 are then connected at luer connection 268 of the main channel of Y-connector 262. The distal tip of the delivery catheter is in place in the coronary sinus at the distal end of the target treatment site. To begin delivery of the device from cartridge 208 into delivery catheter 260, handle 200 is advanced distally toward cartridge 208 and delivery catheter 260. As the handle advances toward the cartridge and toward the patient, pusher 210 moves device 202 distally out of cartridge 208 into Y-connector 262 and then into delivery catheter 260. The structure of the point where the Y-connector's second channel 270 meets the main channel 266—specifically, reduced diameter portion 274 and tab 276—helps prevent the tissue shaping device from expanding and getting caught at the junction of the two channels.

In certain embodiments of the invention, the advancing handle 200 reaches cartridge 208 when or before device 202 reaches the distal end of delivery catheter 260. For example, in the embodiment shown in Figures 14-21, the relative lengths of device 202, pusher 210, handle 200 and delivery catheter 260 are such that

the distal end of handle 200 reaches the proximal end of cartridge 208 before device 202 reaches the distal end of delivery catheter 260. After this point, further advancement of handle 200 places handle housing 226 around cartridge 208 so that cartridge 208 moves inside the handle. A flat interior surface (not shown) formed in handle 200 mates with one of the flat sides of cartridge 208 to prevent relative rotation between the cartridge and the handle as control nut 250 rotates.

In one embodiment, rotating control nut 250 is threaded onto cartridge 208 prior to use of the system to treat a patient, as shown in Figure 14. The location of control nut 250 on cartridge 208 depends on the length of the device 202 within cartridge 208 as well as the relative lengths of the pusher and delivery catheter. In this embodiment, these elements are sized and configured so that control nut 250 engages with, and snaps to, the distal end of handle 200 at the point during device delivery when device 202 has reached the distal end of delivery catheter 260. This action engages cartridge 208 with handle 200 for controlled delivery and deployment of tissue shaping device 202. Alternatively, control nut 250 can be disposed on the distal end of handle 200 from the start. In this case, cartridge 208 engages handle 200 through control nut 250 as soon the proximal end of cartridge 208 reaches handle 200, which may be before device 202 has reached the distal end of delivery catheter 260.

After cartridge 208 engages handle 200 through control nut 250, all further relative movement between cartridge 208 and handle 200 is controlled by rotating control nut 208. When tissue shaping device 202 is at the distal end of catheter 260 at the distal end of the target treatment site (as determined fluoroscopically, e.g.) the physician ceases moving handle 200 toward the patient. Instead, handle 200 (and therefore device 202) is held stationary while cartridge 208 and delivery catheter 260 are pulled proximally by rotating control nut 250. This action exposes the device's distal anchor 204, which begins to self-expand. Control nut 250 is then rotated the other direction to advance delivery catheter 260 distally to apply a force to the proximal side of anchor 204 to further expand and lock the anchor, i.e., by advancing the anchor's lock loop over its lock bump, as described above. Thus, control nut 250 acts as an actuator for expanding and locking the device's distal anchor.

After locking the distal anchor, a proximal cinching force is applied to the device through tether 216 to reshape the mitral valve annulus by moving handle 200 proximally away from the patient, preferably while observing the status of the patient's mitral valve regurgitation and vital signs, such as described in U.S. Patent Appl. S.N. 10/366,585, "Method of Implanting a Mitral Valve Therapy Device." Contrast dye may be injected via connector 262 to visualize the anchor while cinching. When an appropriate amount of mitral valve regurgitation has been achieved, control nut 250 is rotated while holding handle 200 in place to pull delivery catheter 260 proximally with respect to tissue shaping device 202, thereby exposing proximal anchor 206, which begins to self-expand.

In one embodiment of the invention, locking sleeve 220 is used in place of the larger diameter delivery catheter to further expand and lock proximal anchor 206 in order to avoid inadvertent recapture of the proximal anchor by the delivery catheter. Screw down portion 223 of knobs 222 is loosened to permit knobs 222 to slide forward in tracks 224, thereby advancing locking sleeve 220 distally toward anchor 206. Locking sleeve 220 applies a distally directed force on the proximal side of anchor 206 to further expand and lock the anchor, i.e., by advancing the anchor's lock loop over its lock bump, as described above. Thus, knobs 222 act as an actuator for expanding and locking the device's proximal anchor. Expansion and locking of the proximal anchor

maintains the cinching action and, therefore, the reduction in mitral valve regurgitation caused by the device's reshaping of the mitral valve annulus.

Alternatively, the delivery catheter can be used to expand and lock the proximal anchor in the same manner as the distal anchor.

The delivery system of this embodiment enables the tissue shaping device to be fully deployed before it is detached from the delivery system. If the tissue shaping device's placement is satisfactory, the device is unhitched from the delivery system. To unhitch, release knob 240 is rotated to move release knob and the attached hitch wire 218 proximally with respect to device 202. This action pulls the distal end of hitch wire 218 out of the device's proximal anchor crimp 207 and releases the looped end of tether 216, thereby disengaging device 202 from the delivery system. The delivery catheter, tether and hitch wire may then be removed from the patient.

The slots 242 in release knob 240 prevent rotation of release knob 240 when locking sleeve 220 is in its proximal-most position. This device release interlock feature helps ensure that the locking sleeve has been used to lock the proximal anchor before the tissue shaping device is disengaged from the delivery system.

In certain instances, after initial deployment but before disengaging the hitch wire and tether the tissue shaping device may need to be recaptured and either removed from the patient or deployed at a different site. In that case, locking sleeve 220 is advanced distally to the proximal side of proximal anchor 206 by moving knobs 222 forward in tracks 224. While holding handle 200 stationary to hold device 202 against distal movement through the action of tether 216, control nut 250 is rotated to advance delivery catheter 260 distally over locking sleeve 220 to and over proximal anchor 206, deforming anchor 206 so that it fits back inside catheter 260. In this manner, control nut 250 is used as a recapture actuator; use of the control nut to apply the recapture force helps prevent a sudden inadvertent distal advancement of the catheter when the anchor collapses and enters the catheter. Once the proximal anchor has been recaptured into the delivery catheter, the catheter is then advanced further distally to recapture distal anchor 204 in the same way. Device 202 can then be moved or removed from the patient.

While preferred embodiments of the present invention have been shown and described herein, it will be obvious to those skilled in the art that such embodiments are provided by way of example only. Numerous variations, changes, and substitutions will now occur to those skilled in the art without departing from the invention. It should be understood that various alternatives to the embodiments of the invention described herein may be employed in practicing the invention. It is intended that the following claims define the scope of the invention and that methods and structures within the scope of these claims and their equivalents be covered thereby.

CLAIMS

WHAT IS CLAIMED IS:

1. A housing adapted for delivery of a medical device to a patient comprising:
a body having a central lumen and at least one flat side, wherein said housing is adapted to be coupled to a delivery apparatus for displacement of said medical device from said central lumen to a lumen in said patient.
2. The housing of claim 1 wherein said housing has a male luer connector at its distal end.
3. The housing of claim 1 wherein said body has at least one flat side.
4. The housing of claim 1 wherein said body has a hexagonal cross-section.
5. The housing of claim 1 further comprising a seal at the proximal end of said housing.
6. The housing of claim 1 wherein said delivery apparatus comprises a catheter.
7. The housing of claim 1 further comprising threads adapted to interact with said delivery apparatus.
8. The housing of claim 1 wherein said medical device is a mitral valve annuloplasty device.
9. The housing of claim 1 wherein said medical device comprises an anchor.
10. The housing of claim 1 wherein said medical device comprises a distal anchor and a proximal anchor.
11. The housing of claim 1 wherein said medical device is a tissue shaping device.
12. The housing of claim 1 wherein said medical device is adapted to being deployed within a lumen of a vessel.
13. The housing of claim 9 wherein said anchor is expandable.
14. The housing of claim 9 wherein said anchor is self-expandable.
15. The housing of claim 9 wherein said medical device further comprises a locking element adapted for reversibly locking said anchor in an expanded configuration.
16. The housing of claim 10 wherein said medical device further comprises a distal locking element adapted to reversibly lock said distal anchor and a proximal locking element adapted to lock said proximal anchor.
17. The housing of claim 1 wherein said housing is adapted to be coupled to the proximal end of said delivery apparatus.
18. A housing adapted for delivery of a medical device to a patient comprising:
a body having a central lumen, said body having a hexagonal cross-section and said lumen adapted for containing said medical device in a non-expanded configuration.
19. The housing of claim 18 wherein said medical device is a mitral valve annuloplasty device.
20. The housing of claim 18 wherein said medical device comprises an anchor.
21. The housing of claim 18 wherein said medical device comprises a proximal anchor and a distal anchor.

22. The housing of claim 18 wherein said medical device is a tissue shaping device.
23. The housing of claim 18 wherein said medical device is adapted to being deployed within a lumen of a vessel.
24. The housing of claim 20 wherein said anchor is expandable.
25. The housing of claim 20 wherein said anchor is self-expandable.
26. The housing of claim 20 wherein said medical device comprises a locking element adapted for reversibly locking said anchor in an expanded configuration.
27. The housing of claim 21 wherein said medical device comprises a distal locking element adapted to reversibly lock said distal anchor and a proximal locking element adapted to lock said proximal anchor.
28. A tissue shaping system comprising:
 - a tissue shaping device;
 - a delivery catheter adapted for delivering said tissue shaping device from outside a patient to a target site within a lumen of said patient; and
 - a dye port adapted to admit an imaging contrast agent to said lumen.
29. The tissue shaping system of claim 28 wherein said tissue shaping device is a mitral valve annuloplasty device.
30. The tissue shaping system of claim 28 wherein said tissue shaping device comprises an anchor.
31. The tissue shaping system of claim 28 wherein said tissue shaping device comprises a proximal anchor and a distal anchor.
32. The tissue shaping system of claim 28 wherein said tissue shaping device is adapted to being deployed within a lumen of a vessel.
33. The tissue shaping system of claim 28 wherein said delivery catheter is adapted to recapture after delivery of said tissue shaping device.
34. The tissue shaping system of claim 30 wherein said anchor is expandable.
35. The tissue shaping system of claim 30 wherein said anchor is self-expandable.
36. The tissue shaping system of claim 30 wherein said tissue shaping device comprises a locking element adapted for reversibly locking said anchor in an expanded configuration.
37. The tissue shaping system of claim 31 wherein said tissue shaping device comprises a distal locking element adapted to reversibly lock said distal anchor and a proximal locking element adapted to lock said proximal anchor.
38. The tissue shaping system of claim 28 wherein said dye port is adapted to admit said imaging control agent during delivery of said tissue shaping device.
39. A tissue shaping system comprising:
 - a tissue shaping device;
 - a delivery catheter adapted for delivering said tissue shaping device from outside a patient to a target side within a lumen of said patient; and

a connector extending from a proximal end of said delivery catheter, said connector comprising a dye port and a device port, said connector being further adapted for delivery of said tissue shaping device from outside said patient to said delivery catheter.

40. The tissue shaping system of claim 39 wherein said dye port is adapted for delivery of an imaging control agent during delivery of said tissue shaping device.
41. The tissue shaping system of claim 39 wherein said tissue shaping device is a mitral valve annuloplasty device.
42. The tissue shaping system of claim 41 wherein said tissue shaping device comprises an anchor.
43. The tissue shaping system of claim 41 wherein said tissue shaping device comprises a proximal anchor and a distal anchor.
44. The tissue shaping system of claim 41 wherein said tissue shaping device is adapted to being deployed within a lumen of a vessel.
45. The tissue shaping system of claim 39 wherein said delivery catheter is adapted to recapture said tissue shaping device after said tissue shaping device has been delivered.
46. The tissue shaping system of claim 42 wherein said anchor is expandable.
47. The tissue shaping system of claim 42 wherein said anchor is self-expandable.
48. The tissue shaping system of claim 42 wherein said tissue shaping device comprises a locking element adapted for reversibly locking said anchor in an expanded configuration.
49. The tissue shaping system of claim 43 wherein said tissue shaping device comprises a distal locking element adapted to reversibly lock said distal anchor and a proximal locking element adapted to lock said proximal anchor.
50. The tissue shaping system of claim 39 wherein said device port is adapted to be coupled with a housing adapted to contain said tissue shaping device in a non-expanded configuration.
51. The tissue shaping system of claim 50 wherein said housing is adapted for coupling with a delivery apparatus at its proximal end.
52. The tissue shaping system of claim 51 wherein said housing comprises threads adapted to interact with said delivery apparatus.
53. The tissue shaping system of claim 39 wherein said device port is adapted to be coupled with a housing, wherein said housing has at least one flat side.
54. The tissue shaping system of claim 39 wherein said device port is adapted to be coupled with a housing, wherein said housing has a hexagonal cross-section.
55. The tissue shaping system of claim 39 wherein said connector has a female luer connection element at its proximal end.
56. A system for delivery of a tissue shaping medical device to a lumen within a patient's body comprising:
 - a catheter with a proximal end having a first channel and a second channel,
 - said first channel is adapted to receive said tissue shaping medical device at its proximal end and deliver said medical device to said lumen distal to said catheter,
 - said second channel is adapted for receiving an imaging contrast agent and delivering said imaging contrast agent to a location within said patient, and

wherein said tissue shaping medical device is adapted for shaping tissue adjacent to the lumen within said patient.

57. The system of claim 56 wherein said second channel is adapted for delivering said imaging contrast agent during delivery of said tissue shaping medical device.
58. The system of claim 56 wherein said tissue shaping medical device is a mitral valve annuloplasty device.
59. The system of claim 56 wherein said tissue shaping medical device comprises at least two expandable anchors.
60. The system of claim 56 wherein said tissue shaping medical device has an expanded configuration and a non-expanded configuration.
61. The system of claim 60 wherein said first channel is adapted for coupling with a housing comprising said tissue shaping medical device in its non-expanded configuration.
62. The system of claim 61 wherein said housing comprises one flat side.
63. The system of claim 61 wherein said housing has a hexagonal cross-section.
64. The system of claim 61 wherein said housing is adapted for coupling with a delivery apparatus at its proximal end.
65. The system of claim 61 wherein said housing further comprises threads adapted to interact with said delivery apparatus.

1/14

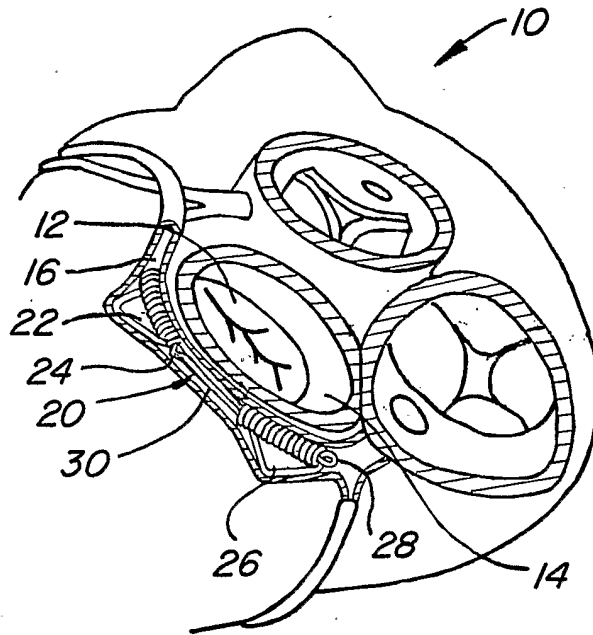

FIG. 1

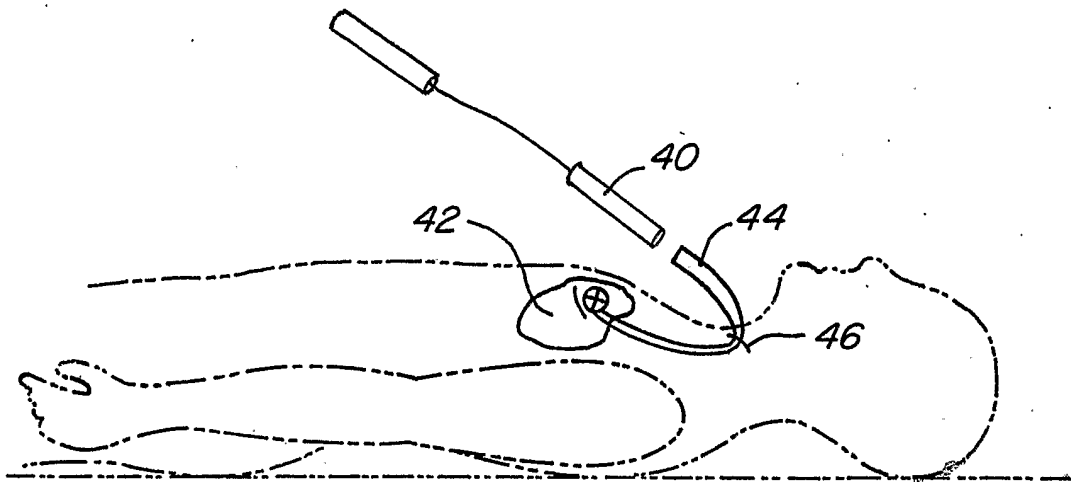

FIG. 2

2/14

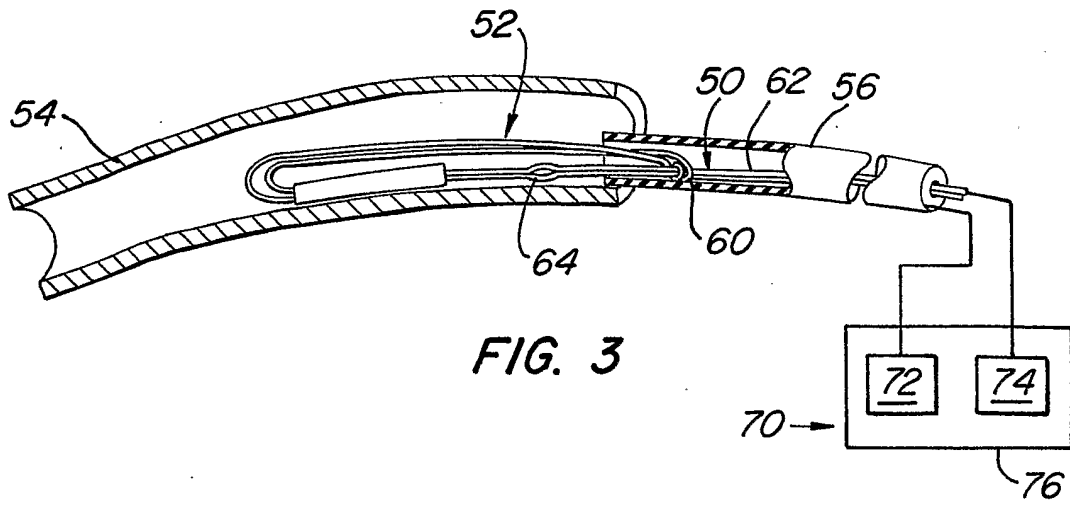

FIG. 3

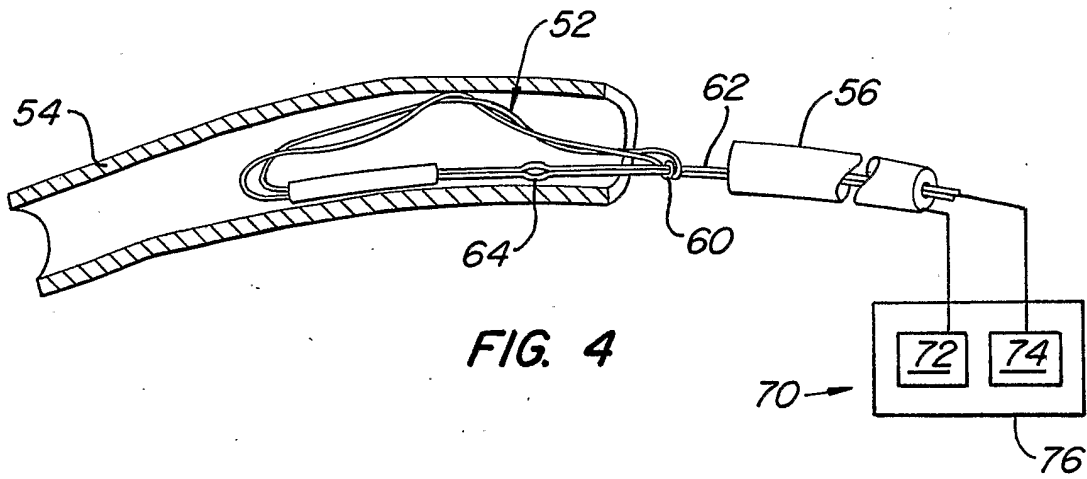

FIG. 4

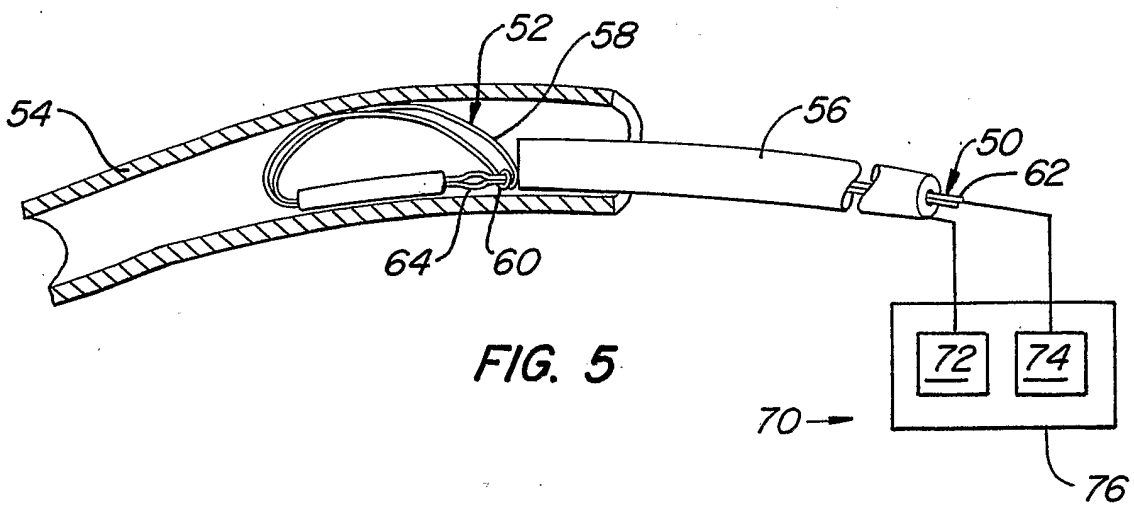
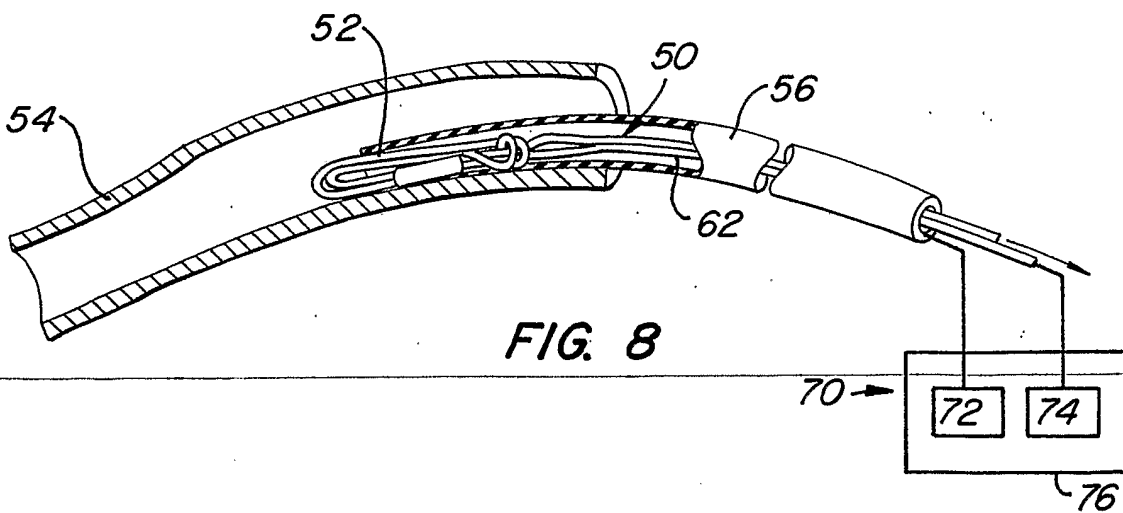
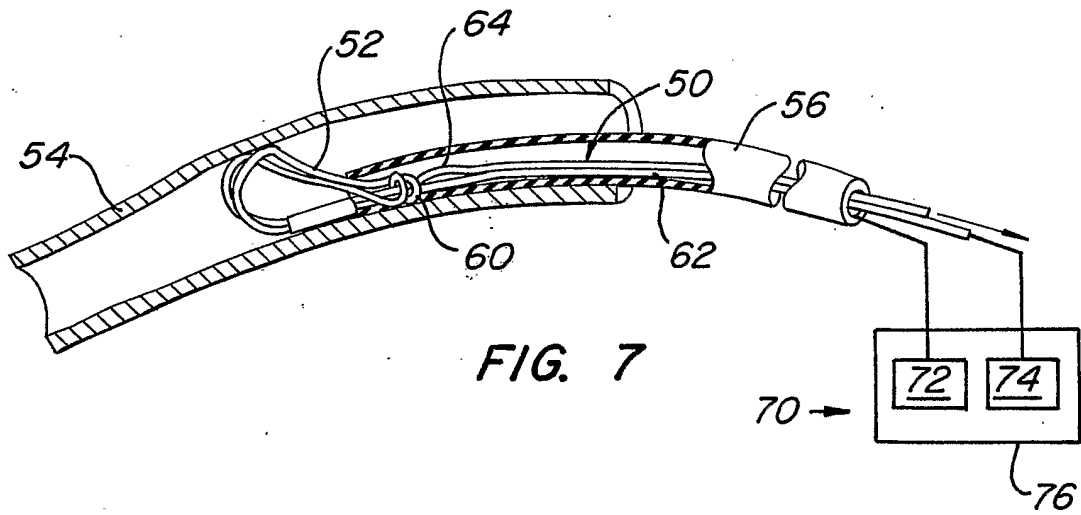
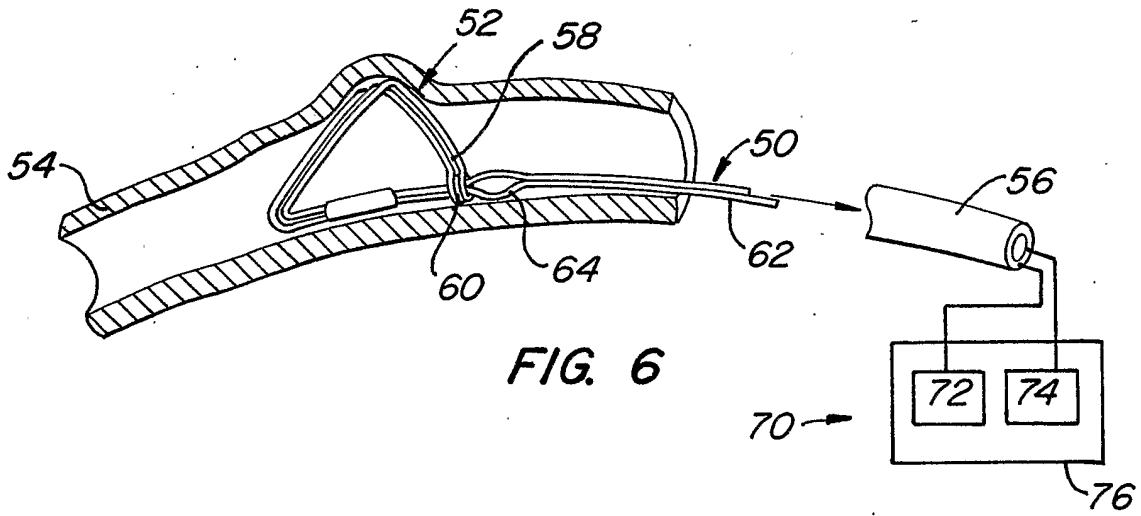

FIG. 5

3/14



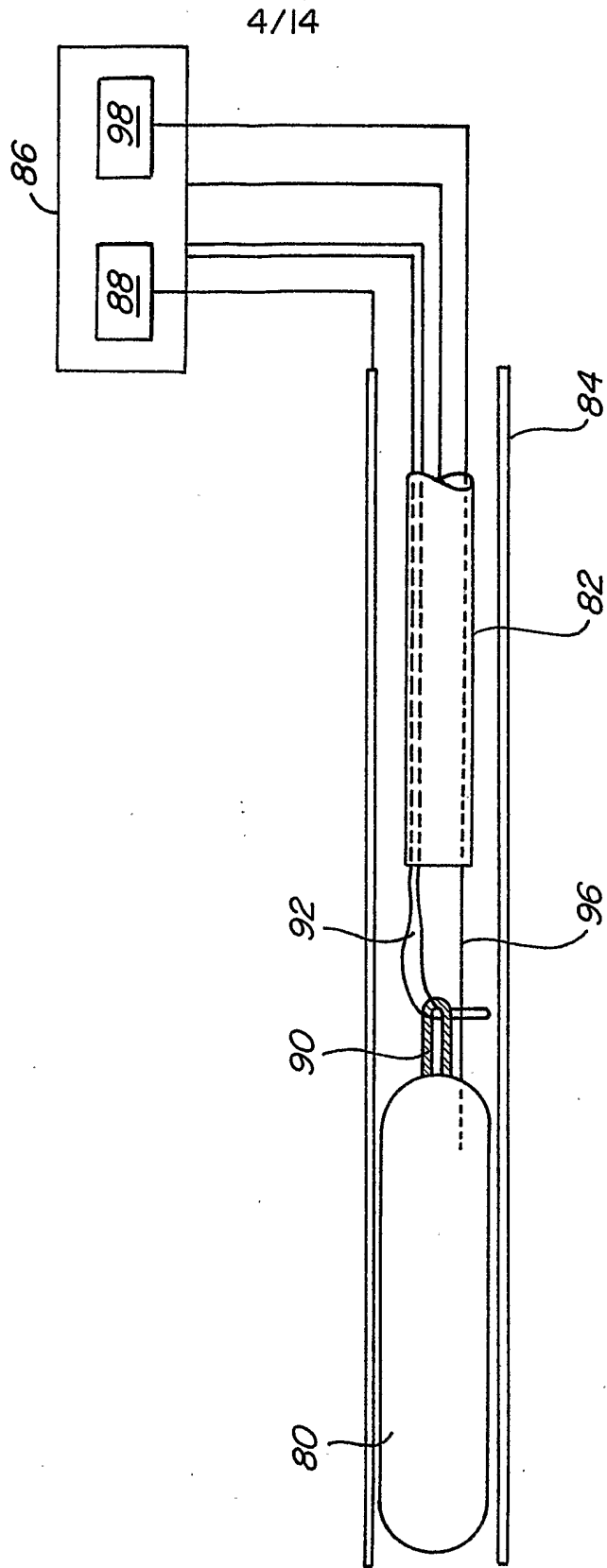

FIG. 9

5/14

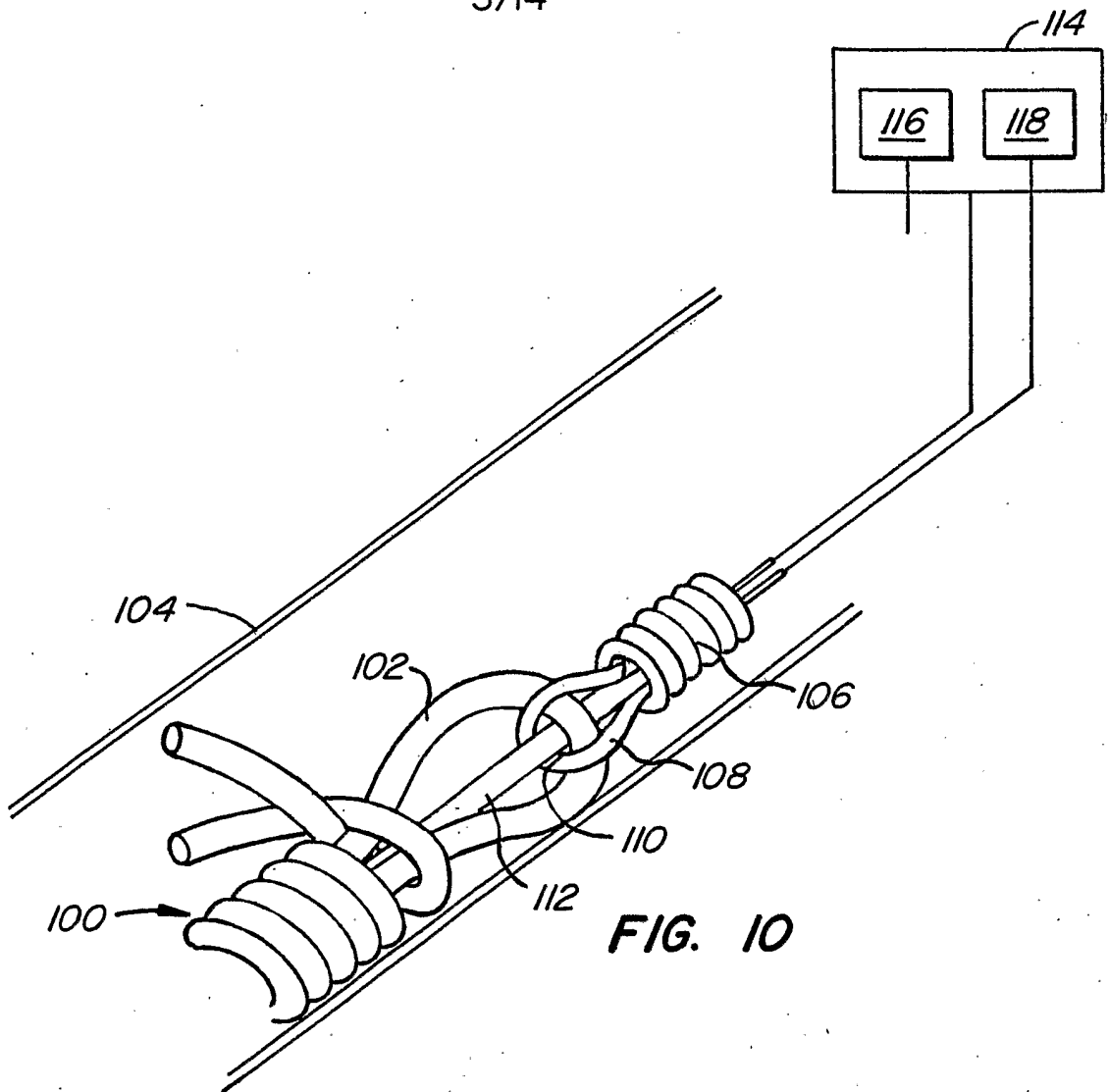

FIG. 10

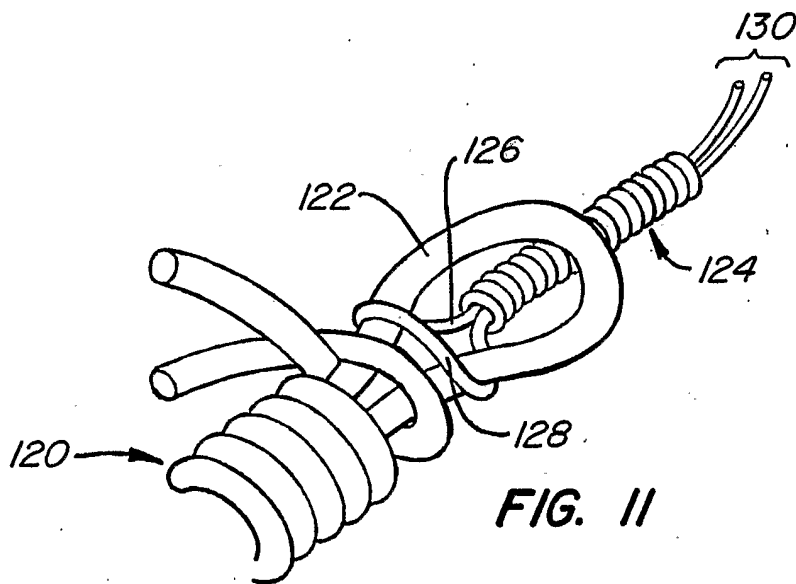

FIG. 11

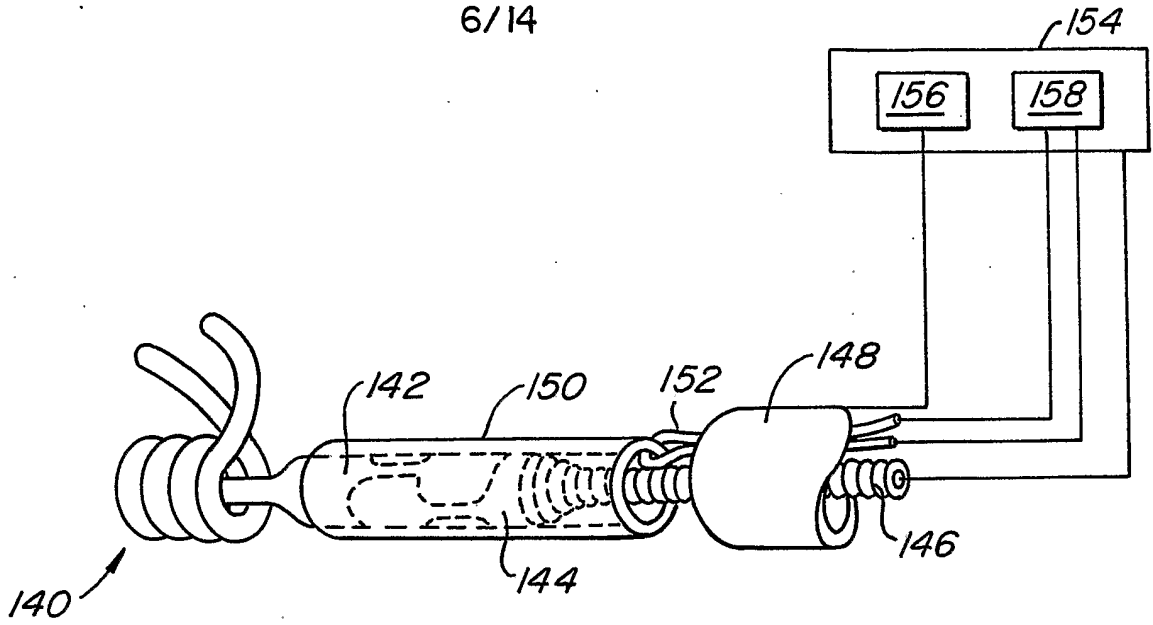

FIG. 12

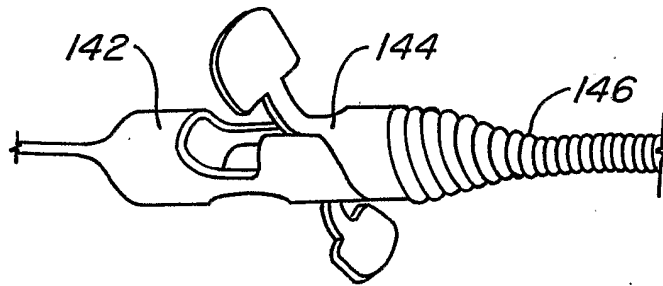

FIG. 13

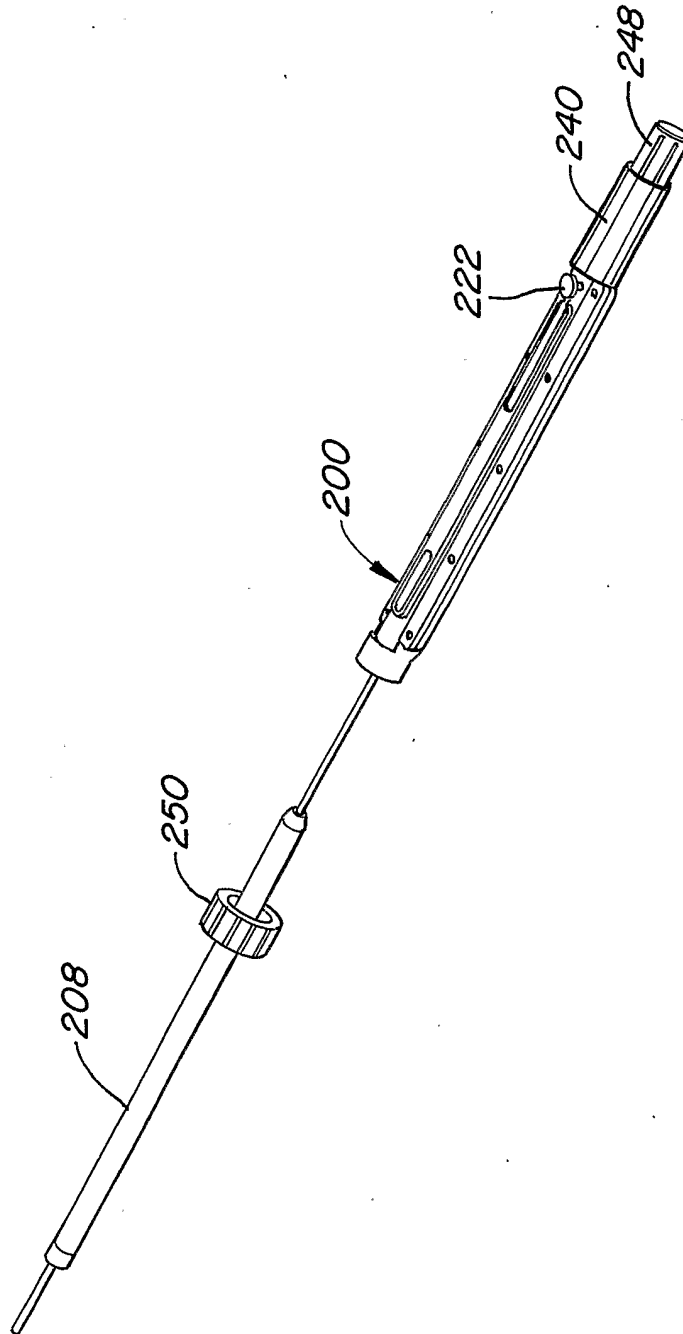

FIG. 14

8/14

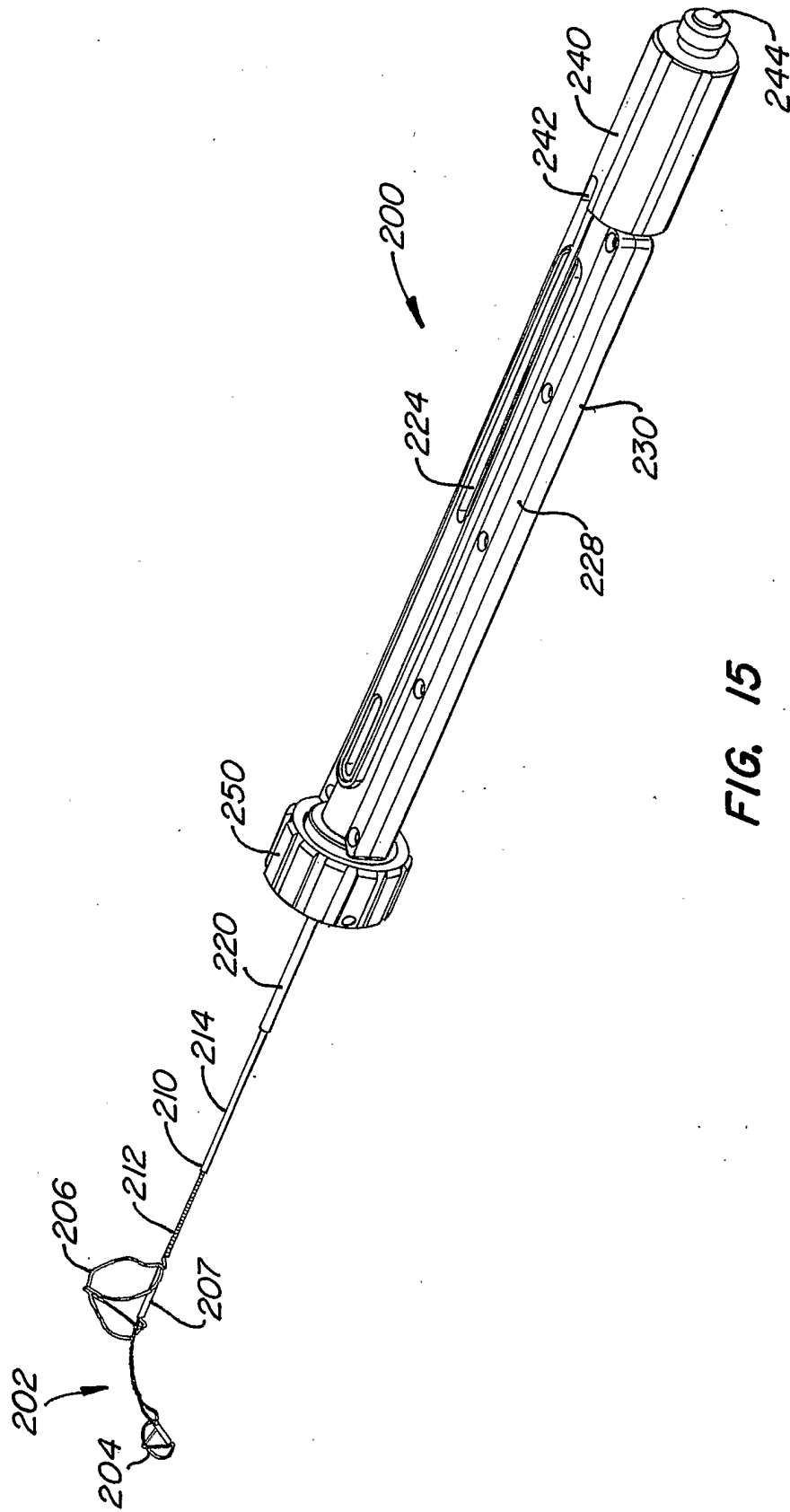

FIG. 15

9/14

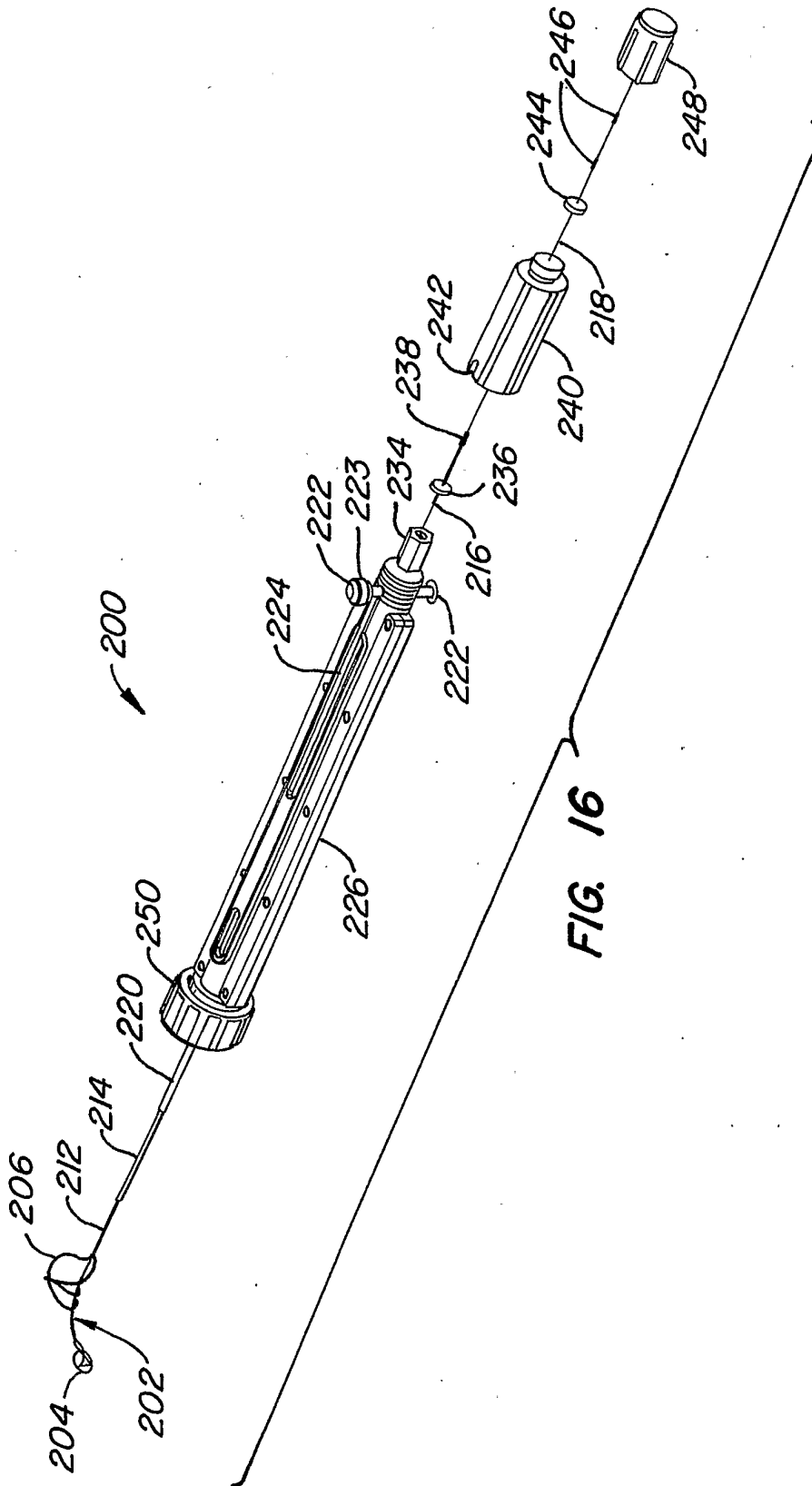

FIG. 16

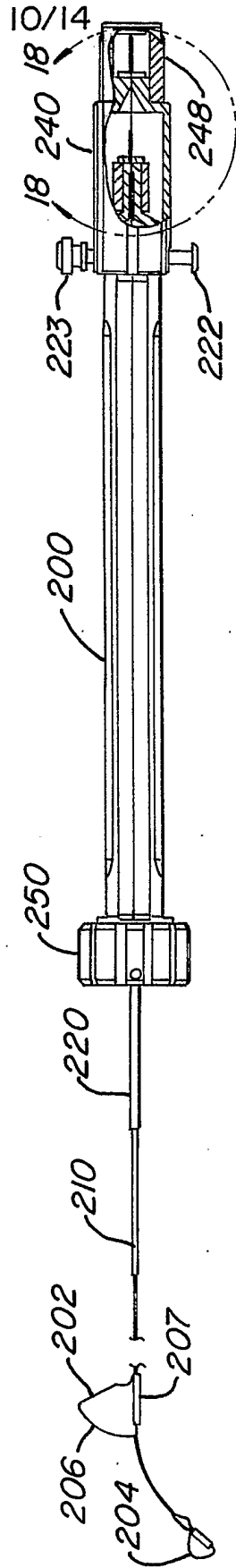

FIG. 17

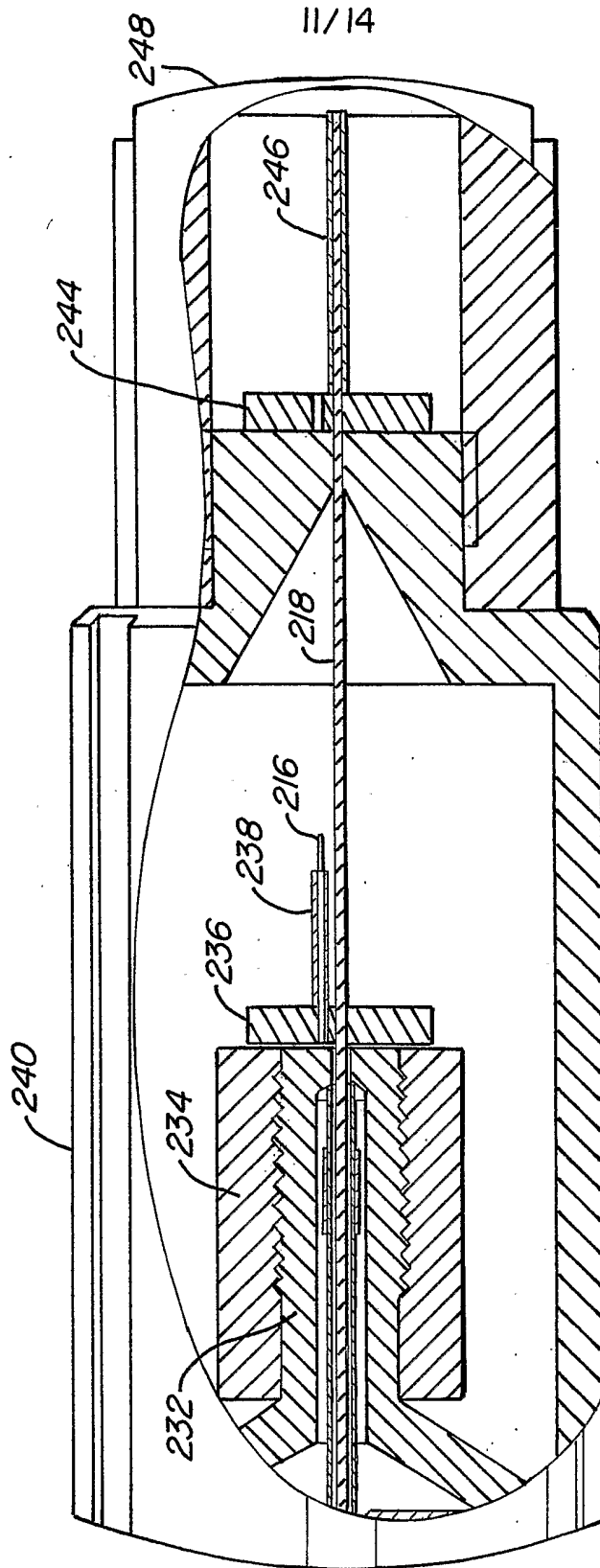
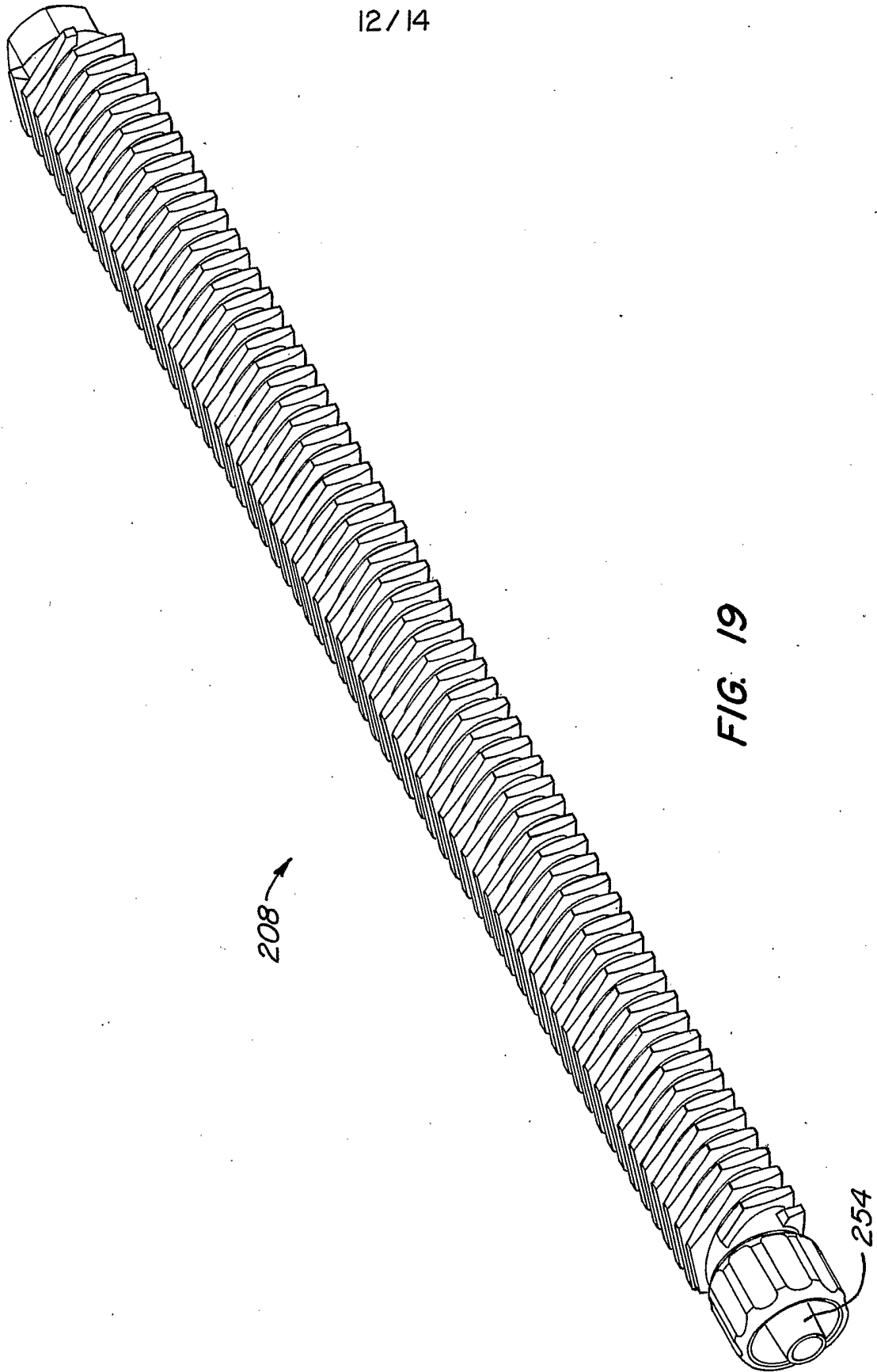

FIG. 18

12/14



13/14

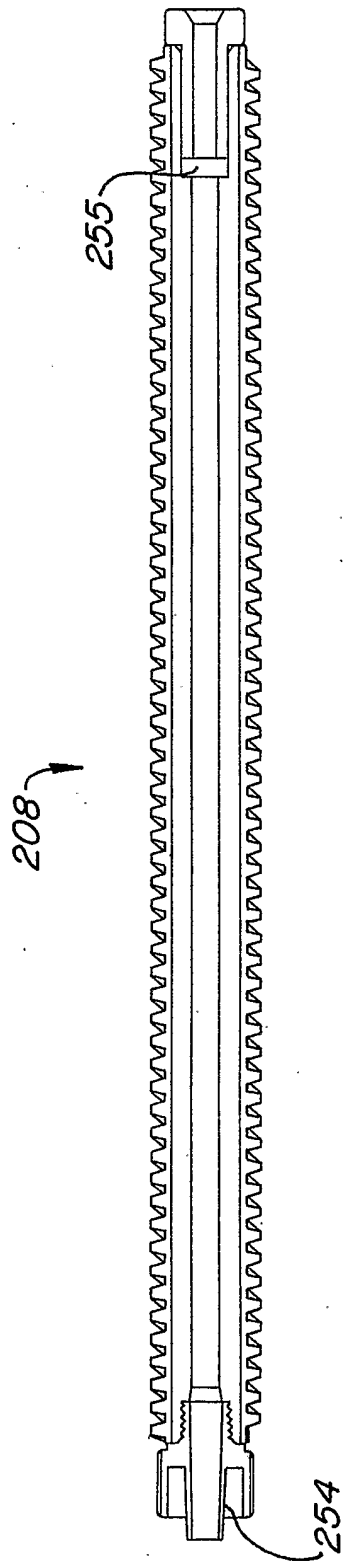

FIG. 20

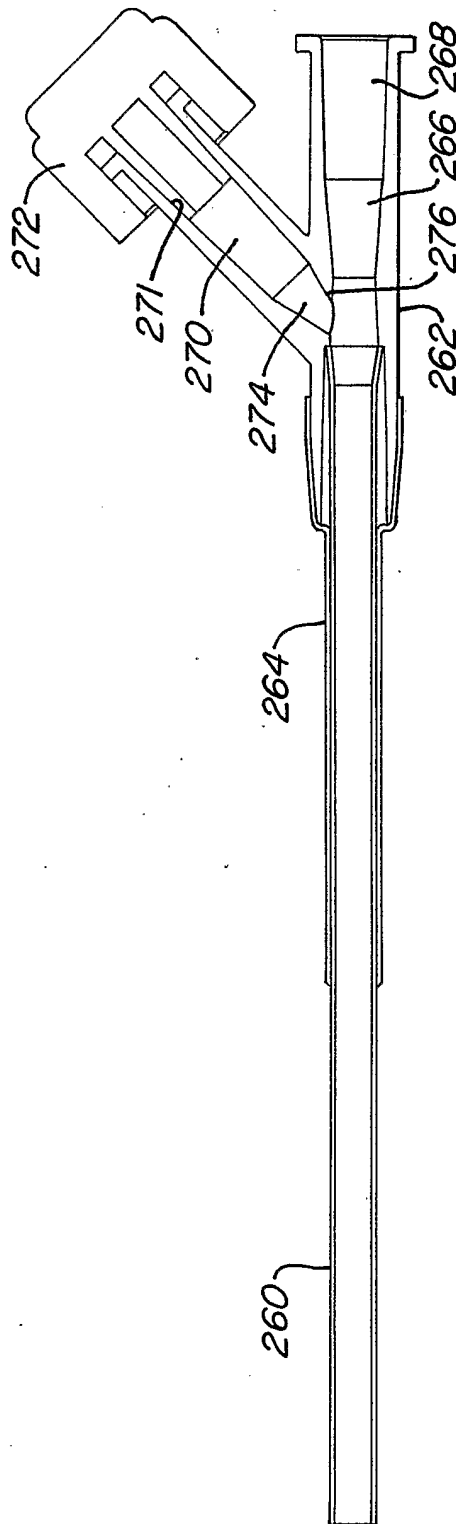

FIG. 21