

STANDABLE FLEXIBLE CONTAINER WITH STRAW

Filed April 29, 1970

2 Sheets-Sheet 1

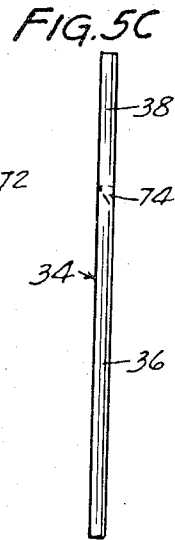
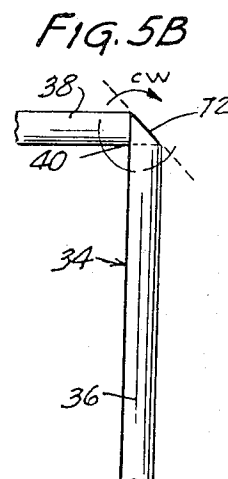
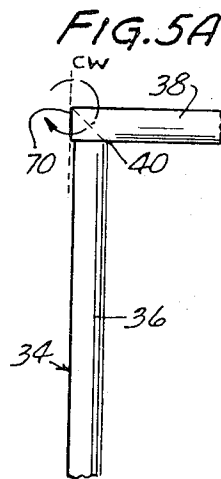
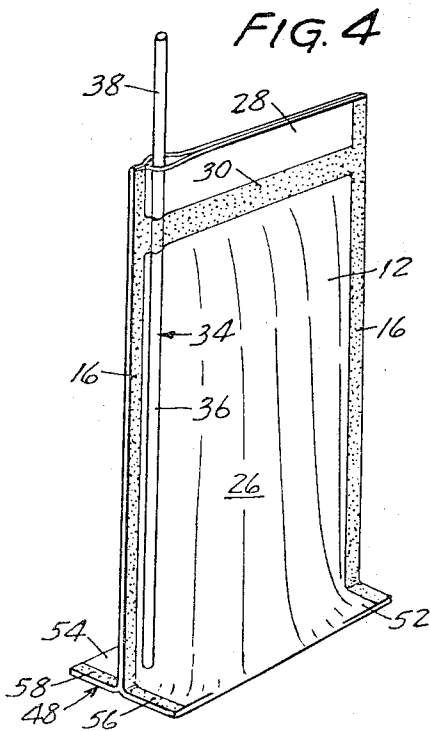
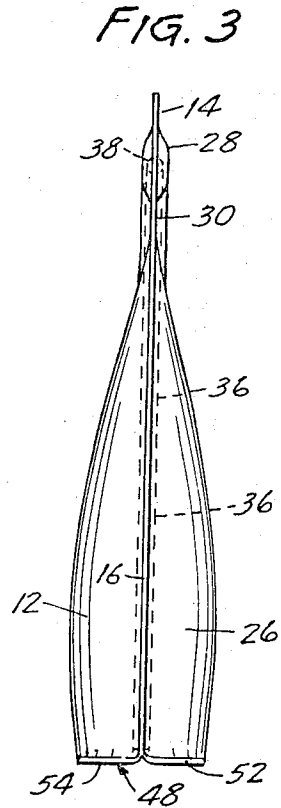
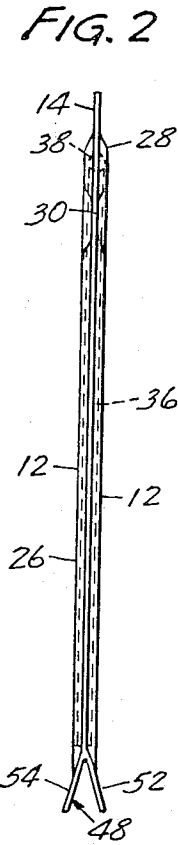
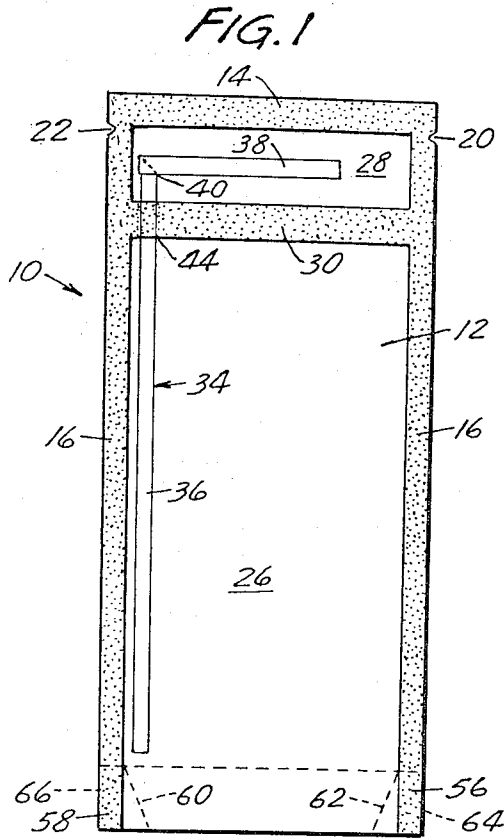

INVENTORS
JUSTIN M. SCHMIT
ROBERT D. CUSHMAN
 BY **HUME, CLEMENT,**
HUME & LEE
 ATTORNEYS

STANDABLE FLEXIBLE CONTAINER WITH STRAW

Filed April 29, 1970

2 Sheets-Sheet 2

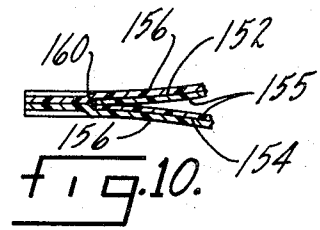
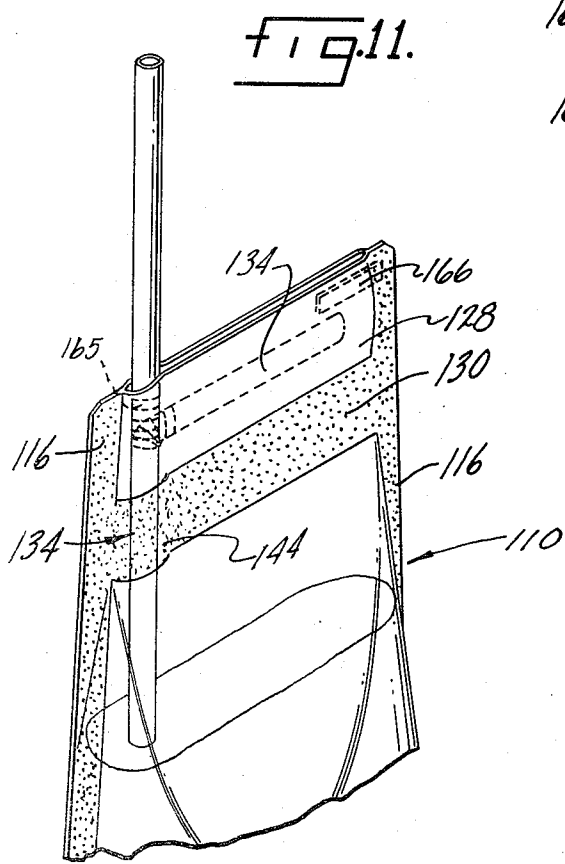
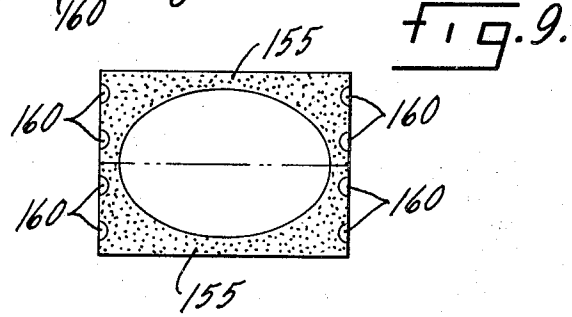
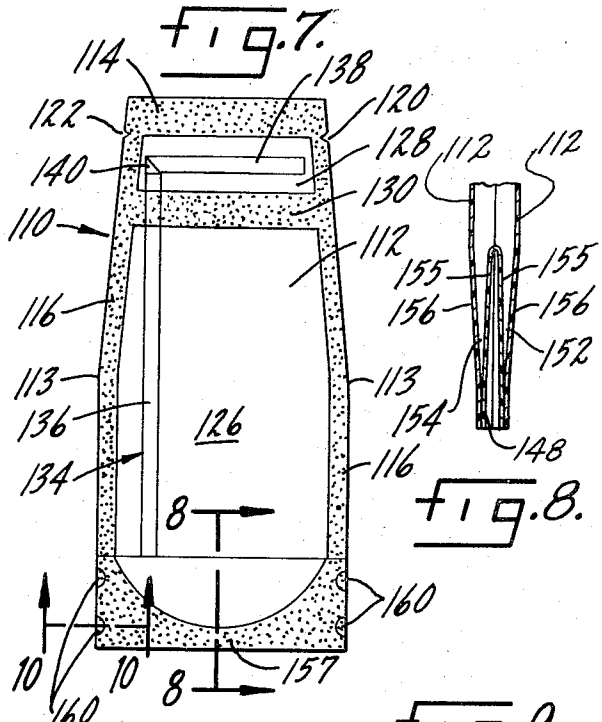
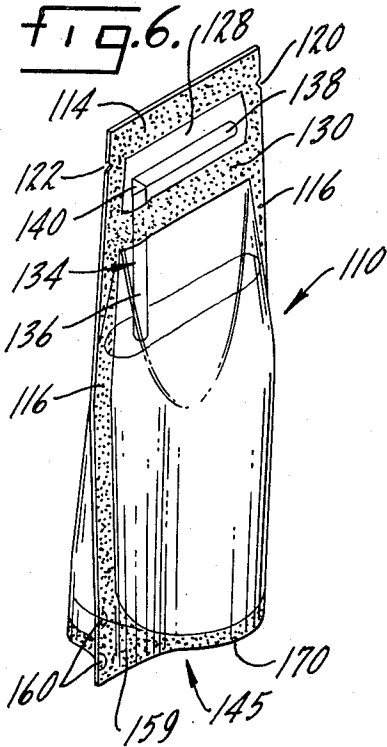

INVENTORS
 JUSTIN M. SCHMIT
 ROBERT D. CUSHMAN
 BY Hume, Clement, Hume & Lee
 Attorneys.

1

2

3,799,914

STANDABLE FLEXIBLE CONTAINER WITH STRAW

Justin M. Schmit, Pompano Beach, Fla., and Robert D. Cushman, Duluth, Minn., assignors to Jenos Inc., Duluth, Minn.

Continuation-in-part of application Ser. No. 19,951, Mar. 16, 1970, now Patent No. 222,237, dated Oct. 12, 1971. This application Apr. 29, 1970, Ser. No. 32,933 The portion of the term of the patent subsequent to Oct. 12, 1985, has been disclaimed

Int. Cl. B65d 47/06, 75/48

U.S. Cl. 426—85

13 Claims

ABSTRACT OF THE DISCLOSURE

A standable flexible container adapted for storing fluids and having side walls formed of a thin, preferably heat sealable, flexible sheet material. The container bottom is constructed so that when the container is filled, the bottom opens to form a broad base for supporting the container of fluid in a standing, upright position. An elongated dispensing member enclosed within the container extends between a lower fluid compartment and an upper, dispensing member storage compartment. The dispensing member has a folded, or foldable, top portion capable of being unfolded into a dispensing position, and a relatively straight bottom portion which extends into the lower compartment. The bottom portion of the dispensing member cooperates with the container side walls to form a fluid tight seal therewith and, in concert with a seal formed in the dispensing member, a hermetic seal is established which isolates stored fluid in the lower compartment.

BACKGROUND OF THE INVENTION

This application is a continuation-in-part of co-pending application, Ser. No. 19,951, filed Mar. 16, 1970, now Pat. No. D. 222,237, issued Oct. 12, 1971, entitled Standable Flexible Container With Straw and Method for Making Same.

Liquid containers with built in drinking straws are known in the prior art. Generally, the containers include either a rigid carton or a flexible pouch. Typical rigid carton containers with drinking straws are shown in U.S. Pats. No. 3,074,612 and No. 3,215,329. In such cartons, the container is formed from a fairly rigid material such as treated cardboard. The straw, in its entire extended length, is enclosed within the interior of the carton. Known flexible containers with straws are shown in U.S. Pats. No. 2,849,321, No. 2,992,118 and No. 3,134,680. Each of these pouch containers is formed from a thin flexible material and each encloses a drinking straw, in its entire extended length, within the liquid filled portion of the pouch. Unlike the rigid carton containers, the flexible pouch containers, when opened, must be held or rested against a fixed support in order to avoid spilling of their liquid contents.

One attempt to overcome the spilling disadvantage of the flexible pouch container is taught in U.S. Pat. No. 3,144,976. A rigid, generally rectangular frame member is used to provide support for the thin flexible material forming the pouch. In addition, the liquid filled pouch includes a main compartment for the liquid and a dispensing compartment for the straw. The lower portions of the two compartments are in communication through a small restricted aperture which restricts the flow of liquid into the dispensing compartment. Thus, when the flexible pouch is laid on its side, liquid must flow through the small restriction in order to spill out of the pouch. Notably, the frame member is not capable of being placed in a standable upright position and the exterior dimensions of

the frame and pouch are dictated by the extended length of the straw.

SUMMARY OF THE INVENTION

The container of the present invention overcomes many of the disadvantages of the prior art containers. The present invention discloses and teaches a standable, flexible container which is formed from a thin flexible material and is adapted for storing fluids. The container of the present invention is capable of enclosing an elongated dispensing member, such as a drinking straw, for example, in a position other than in its entire extended length.

The elongated dispensing member is folded at the top with the bottom portion thereof extending into a fluid compartment or chamber. The top of the fluid chamber is formed by sealing or bonding the side walls together and to the elongated dispensing member whereby a fluid tight seal is formed between the exterior of the bottom portion of the dispensing member and the interior of the side walls formed by the thin flexible material. The folded dispensing member and the fluid tight seal cooperate to form a hermetic seal isolating the fluid in the fluid chamber.

One advantage of the present invention is that a flexible pouch container having a fluid stored therein may be placed, unsupported, in an upright position. One other advantage of the present invention is that the standable flexible container includes, in its preferred form, a folded drinking straw which after opening of the pouch, can be unfolded into a drinking position.

A further advantage of the present invention is that the standable flexible pouch includes a fluid compartment adapted to contain a fluid and the bottom portion of a drinking straw and a separate storage compartment which is adapted to contain the folded top portion of the straw. The drinking straw and seal cooperate to form a hermetic seal isolating the fluid in the fluid chamber during storage. The top portion of the straw is, in turn, initially sealed in its storage compartment. Yet another advantage of the present invention is that a fluid filled, standable, flexible container can be partially collapsed for minimum storage space and immediately expanded for placement in a standing position.

BRIEF DESCRIPTION OF THE DRAWINGS

These and other advantages of the present invention will become readily apparent when considered in light of the detail description of the embodiments disclosed herein taken together with the drawing, wherein:

FIG. 1 is a front view of an empty flexible pouch container having a folded, elongated dispensing member therein and embodying features of one form of the present invention;

FIG. 2 is a side view of the flexible container of FIG. 1 showing a continuous bottom surface of the pouch in a folded position;

FIG. 3 is a side view similar to FIG. 2 with fluid stored in the container and showing the continuous bottom surface in extended position;

FIG. 4 is a perspective view of the opened, fluid filled flexible container of FIG. 3 in a standing position, with the dispensing member unfolded into dispensing position;

FIGS. 5A, 5B, and 5C are a series of views illustrating a folded drinking straw adapted to be enclosed within the flexible container and the sequence in which the straw is unfolded into drinking position;

FIG. 6 is a perspective view of a fluid filled, flexible container embodying features of another form of the present invention;

FIG. 7 is a front view of the empty flexible pouch container shown in FIG. 6;

FIG. 8 is a sectional view taken along line 8—8 of FIG. 7;

3

FIG. 9 is a bottom view of the empty container of FIG. 7, with bottom pleats extended for illustration;

FIG. 10 is a sectional view taken along line 10—10 of FIG. 7; and

FIG. 11 is an enlarged perspective view of a portion of the opened, fluid filled, flexible container of FIG. 6.

DESCRIPTION OF THE PREFERRED EMBODIMENTS

Referring to FIGS. 1-4, a first form of container embodying features of the present invention is illustrated. The container comprises side walls formed from thin flexible sheet material. The side walls are joined together on the top and sides thereof with the bottom portions of each side wall being actually continuous and formed into a continuous bottom surface. The continuous bottom surface is folded into two pleats with the side edges of each pleat being joined together. The continuous bottom surface is expanded when the pleats are opened forming a relatively planar bottom surface for supporting a container of fluid in an upright, standing position.

An elongated dispensing member is enclosed within the side walls. The top portion of the dispensing member is folded while the relatively straight bottom portion thereof extends between the side walls into the fluid. When the top of the flexible pouch is opened, the dispensing member can be unfolded into a dispensing position.

In order to further explain the present invention, reference is first made specifically to FIG. 1. Illustrated in front view, the standable flexible container 10 has two side walls 12 formed of a thin flexible material. For example, the thin flexible material may be a laminated plastic material fabricated of about a 0.25 inch (about .06 cm.) polyester film laminated onto .15 inch (about .4 cm.) polyethylene film. If desired, the container could be formed from Scotch Pak brand "type 5" laminated film sold by the 3M Company. The "type 5" laminated film is capable of being heat sealed with a heated pressure shoe, for example, at a temperature of about 350 degrees F. (about 177 degrees C.) and a pressure of about 60 pounds per square inch (10 lbs./sq. cm.), for a dwell time of 1½ seconds. The polyethylene side of the material is preferably used to form the interior side walls since it is the sealing medium.

The side walls 12 are sealed across a top edge strip 14 and along each side edge strip 16. Notches 20 and 22 are provided to enable removal of the sealed top edge strip 14 and permit access to the interior of the pouch 10. The notches 20 and 22 are V shaped and are cut about halfway into the sealed side edge strips 16.

In the example of FIG. 1, the pouch 10 has two separate compartments, a lower fluid compartment 26 and an upper storage compartment 28. A line or strip of heat sealing 30 separates the fluid compartment 26 from the storage compartment 28.

An elongated dispensing member, for example, a drinking straw 34, is enclosed within the pouch 10. The drinking straw 34 has a relatively straight bottom portion 36 and a foldable top portion 38. A fluid tight seal is formed at the juncture 40 where the straw is folded.

In this form of the invention, one acceptable drinking straw is fabricated of a polyethylene material having a thickness of about .02 inch (about .04 cm.). The straw has an overall circular cross-sectional diameter of about 3/16 inch (about .4 cm.) and an overall length of about 9 inches (about 23 cm.).

The line or strip of heat sealing 30 encircles the upper reaches of the bottom portion 36 of straw 34 to define an aperture 44 which permits the straw bottom portion 36 to be extended into the fluid chamber 26.

A liquid tight seal is formed between the straw 34 and pouch walls 12 in the vicinity of aperture 44 in one of several ways. For example, the interior of the side walls 12 may be fused to the exterior of the bottom

4

portion 36 of straw 34. This is accomplished by selecting the straw and thin flexible sheet of material having properties permitting fusion thereof under heat, such as polyethylene film. Another method is to use an adhesive such as THERMOGRIP brand, hot melt adhesive, type #1324, sold by USM Chemical Company Division of United Shoe Machinery, Middleton, Mass., or Manhattan brand type HM-2450 Hot Melt Adhesive, a thermoplastic synthetic polymer, sold by Manhattan Adhesive Corporation of Brooklyn, N.Y.

The line or strip of heat sealing 30, the seal with the straw 34 in the vicinity of aperture 44 and the folding seal at juncture 40 in the straw, cooperate to form a hermetic seal isolating fluid in the fluid chamber 26.

The bottom portions (below the horizontal dotted line in FIG. 1) of each side wall 12 are joined together in folded relationship to form a continuous bottom surface 48. In order to better explain the construction of the pouch 10 as it relates to the continuous bottom surface 48, reference is now made to the end view of an empty pouch illustrated in FIG. 2.

The continuous bottom surface 48 is folded inwardly and upwardly so as to form a first pleat 52 and a second pleat 54. The side edges of the side wall 12 portions forming the pleats 52 and 54 are joined together, as illustrated in FIG. 1, by sealing them along bottom edge strips 56 and 58.

In the embodiment of FIGS. 1 to 5, the bottom edge strips 56 and 58 are of substantially the same width as the sealed side edge strips 16. Alternatively, the outside edges of each pleat may be sealed in 45-degree triangular shaped gussets illustrated in dotted lines at 60 and 62. During the heat sealing process, the outside edge portion of the triangular shaped gusset seals 60 and 62 of each pleat may be further bonded together at outside edges 64 and 66, respectively, forming a rigid member which provides a more rigid support for the pouch container 10.

The pouch container 10, when filled with fluid, can be placed in a standing upright position, as illustrated by the end view of a fluid filled pouch 10 shown in FIG. 3 or the perspective view of an opened, filled pouch shown in FIG. 4. Referring to FIG. 3, the fluid in the compartment 26 urges the side walls 12 into a bulging position, as illustrated, while concurrently opening the pleats 52 and 54 and expanding the continuous bottom surface 48, thereby forming a relatively planar bottom surface.

When the top edge strip 14 is removed by shearing the side walls 12 between notches 20 and 22, as shown in FIG. 1, the top portion 38 of drinking straw 34 can then be unfolded into a drinking position, as illustrated in FIG. 4.

One method of folding the drinking straw 34 to form the desired hermetic seal is shown in FIG. 5A. It appears easier to understand the seal if the straw is first considered folded. The straw 34 may be unfolded into drinking position by first rotating the top portion 38 thereof, while holding the pouch stationary, in a clock-wise (CW) direction around a crease line 70 parallel to the axis of the lower portion 36 of the straw, as seen in FIG. 5A. Thereafter, the top portion 38 continues to be rotated in a clock-wise (CW) direction although now about a crease line axis 72, disposed at 45-degrees to the crease line 70 and the straw portion 36, as illustrated in FIG. 5A. After the top portion 38 of the straw 34 is unfolded in drinking position, as illustrated in FIG. 5C, it might be necessary to squeeze the straw in area 74 to insure that the straw cross-section is not restricted. The straw may be folded by reversing the above method and steps.

The fluids which may be stored and removed from the standable pouch are many and varied. If the standable pouch is to be used for storage of fluids which are to be poured or otherwise removed from the pouch 10, it is contemplated that the drinking straw 34 and line or strip of heat sealing 30 may be eliminated in a variation of

the first form of the invention. Thus, the fluid may be a liquid, semi-liquid or fine powdery or granular material.

Alternatively, after the straw 38 is in drinking or dispensing position, the fluid may be removed from the fluid compartment by drawing the same through straw 34 or by pouring or pressing the side walls 12 inwardly to force the fluid through the straw 34. Thus, a fluid is deemed to include liquids, semi-liquids or fine, powdery or granular material capable of passing through a straw or elongated dispensing member of a selected size and cross-section.

If desired, the fluid filled pouch 10 and straw may be sterilized using aseptic filling methods, or it may be treated by other processes which sterilize after filling. Alternatively, the fluid filled pouch could be refrigerated or frozen. The pouch or container 10 is well suited for purveying drinkable liquids such as milk or soft drinks or the like.

For purposes of more specifically describing a method of making a standable liquid container with a drinking straw, the following is set forth as an example:

A thin strip of flexible plastic material is selected as described. The plastic is folded and heat sealed along the outside edges to form a container. A typical pouch may be approximately 3.75 inches (about 9.5 cm.) in width and about 7.75 inches (about 20 cm.) in height with about a 1.25 inch (about 3 cm.) open gusset. The outside edges of the bag are sealed approximately 6 inches up from the closed bottom.

A piece of adhesive cellophane tape having a width of approximately .25 inch (about .7 cm.) is placed on both sides on the outside of the container approximately .75 inch (about 2 cm.) to about 1 inch (about 2.5 cm.) from the top. If a heat sealable adhesive is used as described herein, a $\frac{1}{16}$ inch bead (or about .2 cm.) of the thermo setting adhesive is placed around the outside surface of the straw approximately 5 inches (about 12.7 cm.) from the end thereof. A typical straw selected would have an overall length of about 9 inches (about 23 cm.). The drinking straw is inserted into the container such that a bottom portion of the straw is positioned approximately $\frac{5}{8}$ inch (about 1.6 cm.) from the bottom of the bag.

A liquid tight seal is formed between the outer surface of the straw and the inside surface of the container by heat sealing the flexible strip material with approximately a $\frac{1}{2}$ inch wide (about 1 cm.) line or strip of heat sealing horizontally across both sides of the bag and straw about $5\frac{1}{2}$ inches (about 14 cm.) from the bottom and substantially parallel to the bottom. To facilitate filling of the container, only one-half of the total seal strip is formed at this time to enable the filling of the liquid container with fluid through the unsealed portion during a subsequent step. The strip of heat sealing would be formed across the straw at a point approximately 5 inches (about 12.5 cm.) from its bottom end. If necessary, the straw can be manipulated into its normal cross-section to prevent any restrictions from forming as a result of the sealing operation.

Thereafter, the straw can be folded into position by using a folding technique to seal as described in FIGS. 5A and 5B. The bag or pouch can then be filled with liquid through the aforementioned unsealed portion of the bag. The next step is to complete the $\frac{1}{2}$ inch (about 1 cm.) wide seal strip extending across the pouch about $5\frac{1}{2}$ inches (about 14 cm.) to 6 inches (about 15 cm.) from the bottom. Thereafter, with the top portion of the straw twisted or folded into storing position, the upper side edges and top of the storage compartment are heat sealed. The bag is then notched to facilitate easy opening, as illustrated in FIG. 1.

Turning to FIGS. 6-11, a second form of the standable container pouch embodying features of the present invention is illustrated. This form of the container is similar in concept to the container 10 hereinbefore discussed,

but does incorporate several specific features which are different. One such feature is the profile or configuration of the container. In this second form of the container, an upward, inward taper of the side edges of the container is incorporated so that the container, in its filled, standing position, has a narrower upper profile and a lower center of gravity with, accordingly, enhanced stability. Another feature of this form of the invention is its modified base which also lends to increased stability.

Referring now to FIG. 7, a standable, flexible container embodying features of the second form of the invention is illustrated generally at 110. This view, similar to FIG. 1, is a front view of the empty container, which has two side walls 112 formed of a thin flexible material. The flexible material is, once again, preferably a plastic comprising a polyester film laminated with a polyethylene film. The polyethylene film laminations face each other in the main portion of the pouch container to afford heat sealing capabilities where desired.

The side walls 112 are, as illustrated, tapered from adjacent their mid-points, as at 113, upwardly. In a manner hereinafter described in relation to the filled container 110, this configuration is effective to lower the gravity of the filled container (see FIG. 6) and reduce the cross-sectional dimensions of the upper portion of the filled container.

In the container 110, the side walls 112 are once again sealed across a top edge strip 114 and along each side edge strip 116. Notches 120 and 122 are provided to enable removal of the top edge strip 114.

The pouch 110 has a lower fluid compartment 126 and an upper storage compartment 128. A line or strip of heat sealing 130 separates the fluid compartment 126 from the storage compartment 128.

Normally enclosed within the pouch 110 is a drinking straw 134, again preferably formed of polyethylene material. The lower portion 136 of the drinking straw extends into the lower compartment 126 of the container, while the folded, top portion of the straw 138 is disposed in the storage compartment 128.

The straw 134 extends through a suitably formed aperture 144 in the heat sealing strip 130 of the container 110. A liquid tight seal is formed at the aperture 144 with the straw 134, preferably by heat sealing between the compatible polyethylene materials. In the alternative, however, a suitable adhesive could be employed to assure a liquid tight seal between the upper and lower compartments 126 and 128, around the outside of the straw 134.

Above the heat sealing strip 130 within the compartment 128 the straw is folded in the manner hereinbefore described to define a fluid tight seal at its fold 140. This seal, together with the seal at the sealing strip 130 between the package side walls 112 and the exterior of the straw 134, forms a complete hermetic seal which isolates the fluid in the lower fluid compartment 126 until the straw 134 is unfolded, in the manner hereinbefore discussed.

The base 145 of the container 110 is formed in a manner generally similar to the manner in which the bottom 48 of the container 10 hereinbefore described was formed. However, certain modifications in construction make the base 145 support the container 110 somewhat more rigidly and, accordingly, the container 110 has slightly more vertical stability. Where this is desired, it will be recognized that this alternative form of container bottom might be employed.

In practice, as has been discussed in the description of construction and operation of the container 10, the side walls 112 of the container 110 are actually a continuous strip of laminar polyester-polyethylene film, with the polyethylene disposed inwardly of the container. The continuous bottom surface 148 of the container 110 is folded inwardly and upwardly into the interior of the

container so as to form two pleats, a first pleat 152 and a second pleat 154, as best seen in FIG. 8.

Each pleat 152 and 154 has an inner side 155 and an outer side 156, as seen in FIG. 8. The sides 155 and 156 of each pleat are heat sealed together along their entire outer peripheries, in an arcuate pattern, as shown at 157, to seal the lower portion of the container 110 in conjunction with the sealing strips 116. The opposed surfaces in each pleat comprise the polyethylene lamina of the film so they readily heat seal together. The sealed pleats 152 and 154 at this stage can spread out into a planar relationship as illustrated in FIG. 9.

Before the opposed sides 155, 156 of each pleat 152 and 154 are sealed together, however, a pair of semi-circular cut-outs 160 are made through the inner side edges. Then, when the pleats 152 and 154 are heat sealed together in one operation in sandwiched relationship, opposed polyethylene lamina come into face-to-face contact between the two pleats 152 and 154 only at the semi-circular cutouts 160. The side edges of the pleats 152 and 154 are thus joined to each other at the cut-outs 160, as seen in FIG. 10, while the main sealed portions 157 of the pleats remain separable.

As a result, when the container 110 is filled with liquid, as illustrated in FIG. 6, a generally semi-circular bottom is formed in the container in support of the contained fluid. At the same time, because the side edges of the pleats 152 and 154 are sealed together at the cut-outs 160, as illustrated in FIGS. 6 and 10, the lower edge 170 of the container 110 forms a generally elliptical base edge for the container. This relatively wide base edge 170 provides extremely stable footing for the filled container 110.

To use the contents of the container 110, the upper edge 114 is merely ripped off in the manner hereinbefore described in relation to the first form of the container 110, leaving the open container 110. The straw 134, which in this case is fabricated of plastic and, accordingly, has substantial plastic memory, immediately unfolds and tends to return to its straightened relationship. Fluid can then be withdrawn from the container through the straw.

If it is desirable to remove only a portion of the fluid contents of the container, this can be done and the straw refolded into the storage compartment 128, seen in FIG. 11. FIG. 11 illustrates the straw 134 which contains an accordion-like flexible section 165 which facilitates bending and rebending the straw into the dotted line position in compartment 128 wherein it is retained below a short, horizontal seal strip 166 formed immediately adjacent the tear strip upper edge 114. In this variation, the straw would not form a seal at the bend, of course.

It is envisioned that the liquid tight seal described in relation to the containers 10 and 110 is, in its preferred application, most adaptable for use in such a flexible liquid filled pouch. However, the combination of a foldable straw, liquid tight seal, storage compartment, and fluid compartment is also adapted for use with a semi-rigid or rigid container.

Furthermore, although the straws 34 and 134 are illustrated as long, relatively thin members, they might be relatively large in diameter and short enough to extend only a short distance into both the fluid compartment 26 or 126, and the storage compartment 38 or 128. This construction is best suited for viscous liquids, for example.

In addition, with the restorable variation of the straw illustrated in FIG. 11, it is contemplated that the compartment 126 might also be reclosed. This could be accomplished by providing a hood or flap (not shown) on one side wall 112 for slipping over the open top of the container 110.

We claim:

1. A flexible container containing liquid, comprising:

(a) two walls formed from thin, flexible sheet material,

(b) each of said walls having a pair of side edges and a top edge,

(c) corresponding side and top edges of said walls being sealed to each other,

(d) said walls also being sealed together substantially along the length of a seal line which separates the container into a larger compartment containing the liquid and a smaller compartment,

(e) a drinking straw between said walls extending through said seal line so that one end of said straw is open to said larger compartment and the other end of said straw is open to said smaller compartment,

(f) said thin, flexible sheet material and said drinking straw having mating surfaces formed of material capable of being heat sealed together to form a liquid tight seal therebetween at said seal line,

(g) said drinking straw being folded in said smaller compartment to form a fluid tight seal between a top portion of said straw and a bottom portion of said straw.

2. The container of claim 1 further characterized in that:

(a) two folds are formed in folding said top portion of said straw into substantially perpendicular relationship with the bottom portion of said straw,

(b) a first fold of said straw being made on a crease line extending at an angle of approximately 45° to the axis of said bottom portion of said straw, and

(c) a second fold of said straw being made on a crease line extending generally parallel to the axis of the bottom portion of said straw.

3. The container of claim 2 further characterized by and including:

(a) bottom means formed in said container between said walls,

(b) said bottom means being capable of supporting said container in an upright relationship.

4. A flexible container containing liquid comprising:

(a) two walls formed from thin, flexible sheet material,

(b) each of said walls having a pair of side edges and a top edge,

(c) corresponding side and top edges of said walls being sealed to each other,

(d) means sealing said walls together along a seal line which separates the container into a larger compartment containing the liquid and a smaller compartment,

(e) an elongated dispensing member between said walls extending through said seal line so that one end of said member is on one side of said seal line and the other end of said member is on the opposite side of said seal line, and

(f) means normally forming a fluid tight seal in said dispensing member between its ends to prevent the passage of the liquid from said larger compartment to said smaller compartment through said dispensing member until said fluid tight seal is broken.

5. The container of claim 4 further characterized in that:

(a) said drinking straw and said walls are sealed together at said seal line by means of a separate adhesive material.

6. The container of claim 4 further characterized by and including:

(a) bottom means formed in said container between said walls,

(b) said bottom means being capable of supporting said container in an upright relationship.

7. The container of claim 4 further characterized in that:

(a) said thin, flexible sheet material and said drinking straw have mating surfaces formed of material capable of being heat sealed together to form a liquid tight seal therebetween at said seal line.

8. The container of claim 7 further characterized in that:

(a) said thin, flexible sheet material is laminated polyester-polyethylene film, and

(b) said drinking straw is formed from polyethylene.

9. The container of claim 7 further characterized in that:

(a) said thin, flexible material is formed of laminated Mylar-polyethylene film.

10. The container of claim 4 further characterized in that:

(a) said dispensing member comprises a drinking straw,

(b) said drinking straw being folded in said smaller compartment to form said fluid tight seal between a top portion of said straw and a bottom portion of said straw.

11. The container of claim 10 further characterized in that:

(a) said top portion of said straw is folded into substantially perpendicular relationship with the bottom portion of said straw.

12. The container of claim 11 further characterized in that:

(a) two folds are formed in folding said top portion of said straw into substantially perpendicular relationship with the bottom portion of said straw.

13. The container of claim 12 further characterized in that:

(a) a first fold of said straw is made on a crease line extending at an angle of approximately 45° to the axis of said bottom portion of said straw, and

(b) a second fold of said straw is made on a crease line

extending generally parallel to the axis of said bottom portion of said straw.

References Cited

UNITED STATES PATENTS

3,326,695	6/1967	Neuhauser	99—171 B X
3,215,329	11/1965	Pugh, Sr.	229—7 S
2,805,809	9/1957	Pugh	99—171 B UX
2,689,076	9/1954	Jenkins	229—7 S
2,547,362	4/1951	Berry	229—7 S
3,380,646	4/1968	Doyen et al.	229—53 X
3,545,604	12/1970	Gunther, Jr.	229—7 S X
3,240,415	3/1966	Pugh, Sr.	229—7 S
3,486,679	12/1969	Pfahler	229—7 S
2,992,118	7/1961	Daline	99—171 B
3,144,976	8/1964	Freshour	229—7 S
3,303,984	2/1967	Jurena	229—7 S
3,387,701	6/1968	Schneider et al.	229—53 X
3,438,567	4/1969	Bell, Jr.	229—57
3,437,258	4/1969	Kugler	229—58
3,456,867	7/1969	Repko	229—66

OTHER REFERENCES

Design Pat. D. 222,237, Oct. 12, 1971.

FRANK W. LUTTER, Primary Examiner

S. L. WEINSTEIN, Assistant Examiner

U.S. Cl. X.R.

215—1A; 229—7 S; 426—115