



US00D784234S

(12) **United States Design Patent**
Houghton et al.

(10) **Patent No.:** **US D784,234 S**

(45) **Date of Patent:** **** Apr. 18, 2017**

(54) **VEHICLE WHEEL**

(71) Applicant: **Karma Automotive, LLC**, Costa Mesa, CA (US)

(72) Inventors: **Paul Houghton**, Long Beach, CA (US);
Nikola Kostov Stefanov, San Clemente, CA (US)

(73) Assignee: **Karma Automotive LLC**, Costa Mesa, CA (US)

(**) Term: **15 Years**

(21) Appl. No.: **29/573,222**

(22) Filed: **Aug. 3, 2016**

(51) **LOC (10) Cl.** **12-16**

(52) **U.S. Cl.**
USPC **D12/209**

(58) **Field of Classification Search**
USPC D12/204–213
CPC B60B 7/00; B60B 7/02; B60B 7/04; B60B 7/01; B60B 7/06; B60B 3/02; B60B 3/04; B60B 3/06; B60B 3/10; B60B 1/00; B60B 1/08; B60B 1/10; B60B 1/12
See application file for complete search history.

(56) **References Cited**

U.S. PATENT DOCUMENTS

D466,849 S * 12/2002 Lee D12/209
D489,307 S * 5/2004 Tirado D12/209

D510,899 S * 10/2005 Noriega D12/209
D515,999 S * 2/2006 Noriega D12/209
D522,438 S * 6/2006 Kern D12/209
D528,958 S * 9/2006 Kim D12/209
D565,490 S * 4/2008 Tirado D12/209
D627,700 S * 11/2010 Ectors D12/209
D680,488 S * 4/2013 Campbell D12/211
D743,865 S * 11/2015 Rueckheim D12/209
D755,697 S * 5/2016 Tirado D12/209
D766,153 S * 9/2016 Wheel D12/209

* cited by examiner

Primary Examiner — Stacia Cadmus

(74) *Attorney, Agent, or Firm* — Farjami & Farjami LLP

(57) **CLAIM**

The ornamental design for a vehicle wheel, as shown and described.

DESCRIPTION

FIG. 1 is a front view of a vehicle wheel, according to the design;
FIG. 2 is a left-side perspective view of the vehicle wheel, according to the design; and,
FIG. 3 is a right-side perspective view of the vehicle wheel, according to the design.

1 Claim, 3 Drawing Sheets

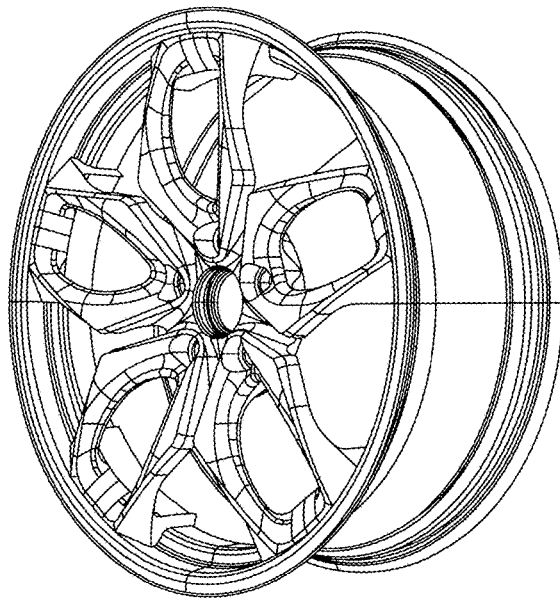
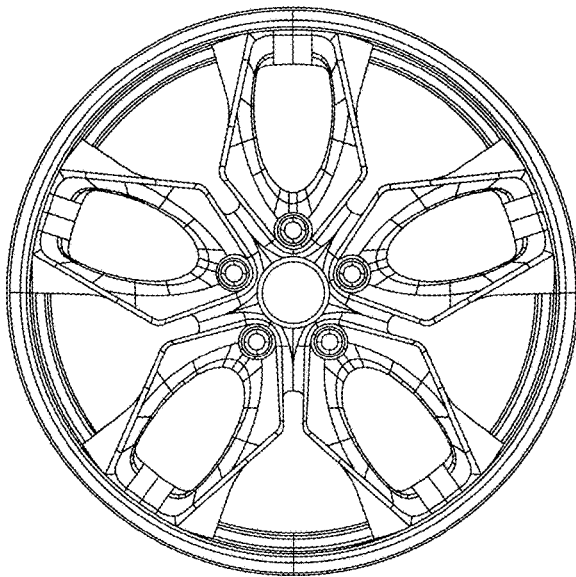

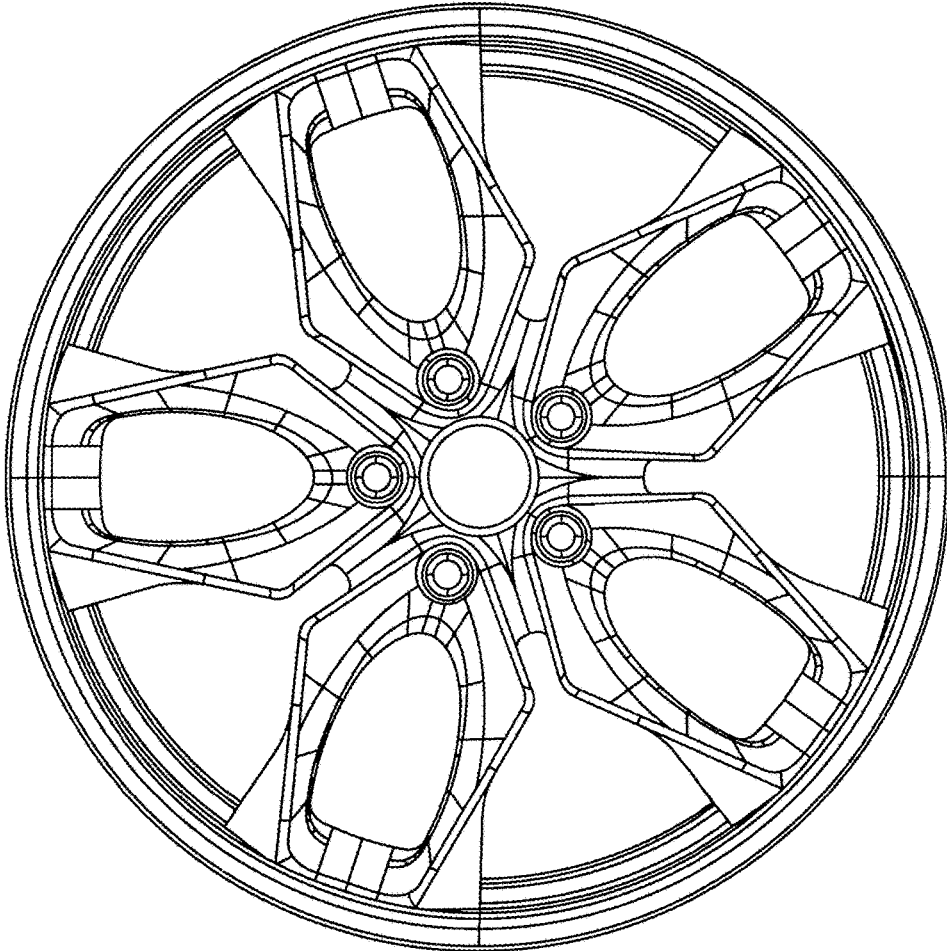

FIG. 1

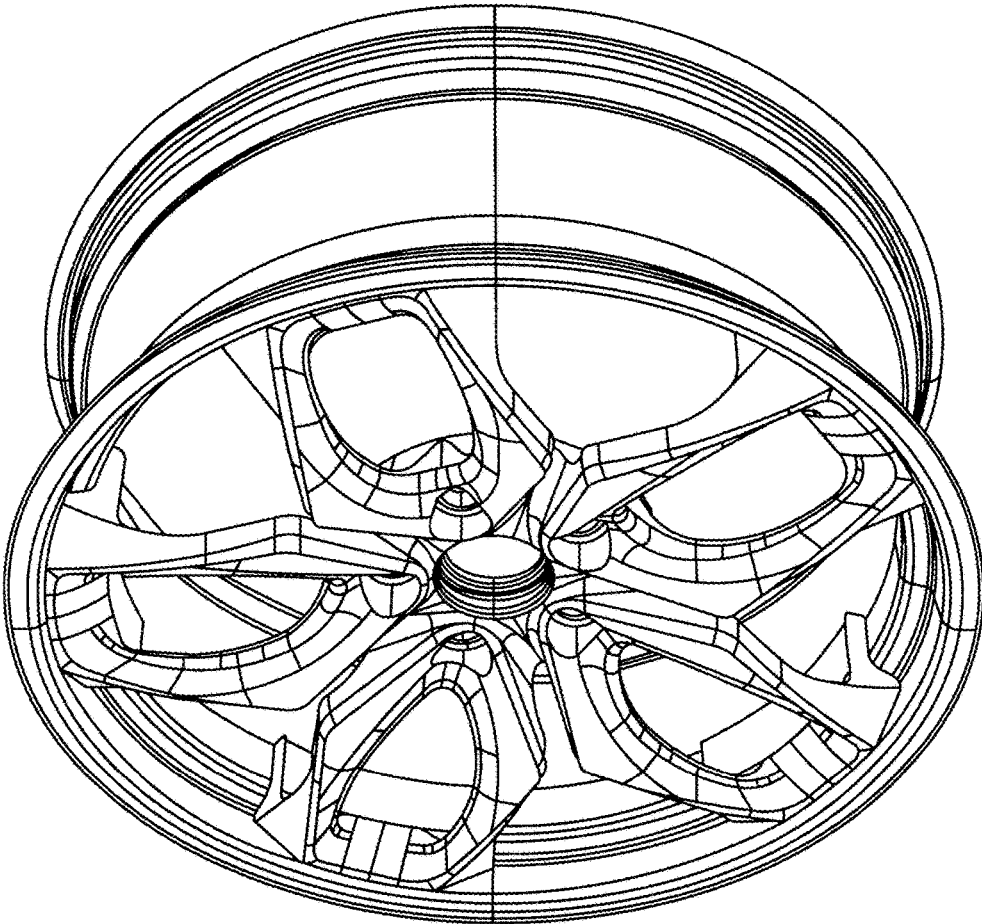

FIG. 2

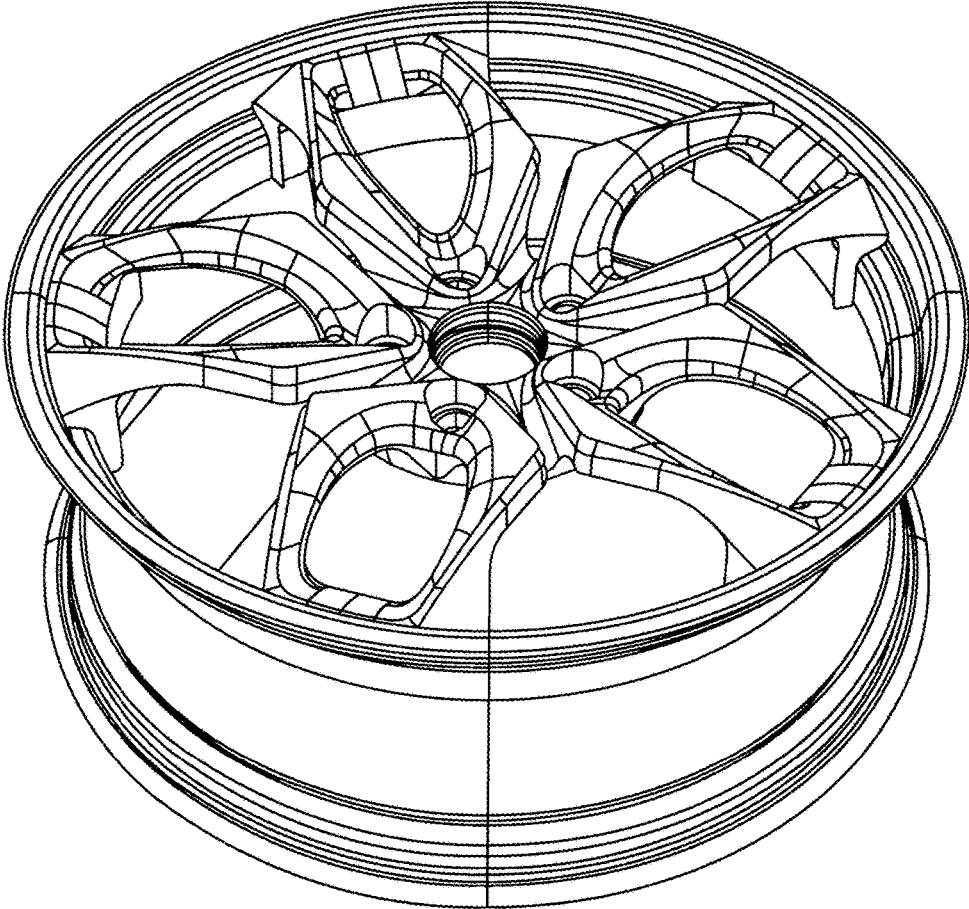

FIG. 3