

(19) World Intellectual Property Organization
International Bureau



(43) International Publication Date
6 October 2011 (06.10.2011)

(10) International Publication Number
WO 2011/123581 A1

- (51) **International Patent Classification:**
H04W 72/12 (2009.01) *H04W 16/14* (2009.01)
- (21) **International Application Number:**
PCT/US2011/030614
- (22) **International Filing Date:**
30 March 2011 (30.03.2011)
- (25) **Filing Language:** English
- (26) **Publication Language:** English
- (30) **Priority Data:**
61/319,100 30 March 2010 (30.03.2010) US
13/074,842 29 March 2011 (29.03.2011) US
- (71) **Applicant (for all designated States except US):** **QUALCOMM INCORPORATED** [US/US]; 5775 Morehouse Drive, San Diego, California 92121 (US).
- (72) **Inventors; and**
- (75) **Inventors/Applicants (for US only):** **KADOUS, Tamer A.** [EG/US]; 5775 Morehouse Drive, San Diego, California 92121 (US). **MANTRAVADI, Ashok** [US/US]; 5775 Morehouse Drive, San Diego, California 92121 (US). **SADEK, Ahmed K.** [EG/US]; 5775 Morehouse Drive, San Diego, California 92121 (US).
- (74) **Agent:** **PATEL, Rupit M.**; 5775 Morehouse Drive, San Diego, California 92121 (US).

- (81) **Designated States (unless otherwise indicated, for every kind of national protection available):** AE, AG, AL, AM, AO, AT, AU, AZ, BA, BB, BG, BH, BR, BW, BY, BZ, CA, CH, CL, CN, CO, CR, CU, CZ, DE, DK, DM, DO, DZ, EC, EE, EG, ES, FI, GB, GD, GE, GH, GM, GT, HN, HR, HU, ID, IL, IN, IS, JP, KE, KG, KM, KN, KP, KR, KZ, LA, LC, LK, LR, LS, LT, LU, LY, MA, MD, ME, MG, MK, MN, MW, MX, MY, MZ, NA, NG, NI, NO, NZ, OM, PE, PG, PH, PL, PT, RO, RS, RU, SC, SD, SE, SG, SK, SL, SM, ST, SV, SY, TH, TJ, TM, TN, TR, TT, TZ, UA, UG, US, UZ, VC, VN, ZA, ZM, ZW.
- (84) **Designated States (unless otherwise indicated, for every kind of regional protection available):** ARIPO (BW, GH, GM, KE, LR, LS, MW, MZ, NA, SD, SL, SZ, TZ, UG, ZM, ZW), Eurasian (AM, AZ, BY, KG, KZ, MD, RU, TJ, TM), European (AL, AT, BE, BG, CH, CY, CZ, DE, DK, EE, ES, FI, FR, GB, GR, HR, HU, IE, IS, IT, LT, LU, LV, MC, MK, MT, NL, NO, PL, PT, RO, RS, SE, SI, SK, SM, TR), OAPI (BF, BJ, CF, CG, CI, CM, GA, GN, GQ, GW, ML, MR, NE, SN, TD, TG).

Declarations under Rule 4.17:

- as to applicant's entitlement to apply for and be granted a patent (Rule 4.17(ii))
- as to the applicant's entitlement to claim the priority of the earlier application (Rule 4.17(iii))

[Continued on next page]

(54) **Title:** METHOD AND APPARATUS FOR MULTI - RADIO COEXISTENCE

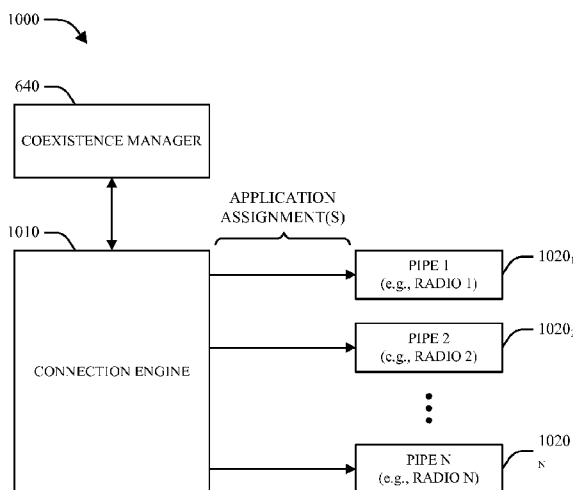

Fig. 10

(57) **Abstract:** A connection engine and coexistence manager are employed to manage radio resources in a user equipment. The connection engine defines desired performance metrics for sets of radio resources. The coexistence manager allocates potentially interfering radio resources to achieve desired performance metrics while accounting for resource capacity, potential collision rates, and other metrics.

WO 2011/123581 A1

Published:

— *with international search report (Art. 21(3))*

METHOD AND APPARATUS FOR MULTI - RADIO COEXISTENCE

CROSS REFERENCE TO RELATED APPLICATION

[0001] This application claims the benefit of U.S. Provisional Patent Application No. 61/319,100 entitled "CONNECTION ENGINE-COEXISTENCE MANAGER INTERFACE," filed March 30, 2010, the disclosure of which is expressly incorporated herein by reference in its entirety.

TECHNICAL FIELD

[0002] The present description is related, generally, to multi-radio techniques and, more specifically, to coexistence techniques for multi-radio devices.

BACKGROUND

[0003] Wireless communication systems are widely deployed to provide various types of communication content such as voice, data, and so on. These systems may be multiple-access systems capable of supporting communication with multiple users by sharing the available system resources (*e.g.*, bandwidth and transmit power). Examples of such multiple access systems include code division multiple access (CDMA) systems, time division multiple access (TDMA) systems, frequency division multiple access (FDMA) systems, 3GPP Long Term Evolution (LTE) systems, and orthogonal frequency division multiple access (OFDMA) systems.

[0004] Generally, a wireless multiple-access communication system can simultaneously support communication for multiple wireless terminals. Each terminal communicates with one or more base stations via transmissions on the forward and reverse links. The forward link (or downlink) refers to the communication link from the base stations to the terminals, and the reverse link (or uplink) refers to the communication link from the terminals to the base stations. This communication link may be established via a single-in-single-out, multiple-in-single-out or a multiple-in-multiple out (MIMO) system.

[0005] Some conventional advanced devices include multiple radios for transmitting/receiving using different Radio Access Technologies (RATs). Examples of RATs include, *e.g.*, Universal Mobile Telecommunications System (UMTS), Global

System for Mobile Communications (GSM), cdma2000, WiMAX, WLAN (e.g., WiFi), Bluetooth, LTE, and the like.

[0006] An example mobile device includes an LTE User Equipment (UE), such as a fourth generation (4G) mobile phone. Such 4G phone may include various radios to provide a variety of functions for the user. For purposes of this example, the 4G phone includes an LTE radio for voice and data, an IEEE 802.11 (WiFi) radio, a Global Positioning System (GPS) radio, and a Bluetooth radio, where two of the above or all four may operate simultaneously. While the different radios provide useful functionalities for the phone, their inclusion in a single device gives rise to coexistence issues. Specifically, operation of one radio may in some cases interfere with operation of another radio through radiative, conductive, resource collision, and/or other interference mechanisms. Coexistence issues include such interference.

[0007] This is especially true for the LTE uplink channel, which is adjacent to the Industrial Scientific and Medical (ISM) band and may cause interference therewith. It is noted that Bluetooth and some Wireless LAN (WLAN) channels fall within the ISM band. In some instances, a Bluetooth error rate can become unacceptable when LTE is active in some channels of Band 7 or even Band 40 for some Bluetooth channel conditions. Even though there is no significant degradation to LTE, simultaneous operation with Bluetooth can result in disruption in voice services terminating in a Bluetooth headset. Such disruption may be unacceptable to the consumer. A similar issue exists when LTE transmissions interfere with GPS. Currently, there is no mechanism that can solve this issue since LTE by itself does not experience any degradation.

[0008] With reference specifically to LTE, it is noted that a UE communicates with an evolved NodeB (eNB; e.g., a base station for a wireless communications network) to inform the eNB of interference seen by the UE on the downlink. Furthermore, the eNB may be able to estimate interference at the UE using a downlink error rate. In some instances, the eNB and the UE can cooperate to find a solution that reduces interference at the UE, even interference due to radios within the UE itself. However, in conventional LTE, the interference estimates regarding the downlink may not be adequate to comprehensively address interference.

[0009] In one instance, an LTE uplink signal interferes with a Bluetooth signal or WLAN signal. However, such interference is not reflected in the downlink

measurement reports at the eNB. As a result, unilateral action on the part of the UE (e.g., moving the uplink signal to a different channel) may be thwarted by the eNB, which is not aware of the uplink coexistence issue and seeks to undo the unilateral action. For instance, even if the UE re-establishes the connection on a different frequency channel, the network can still handover the UE back to the original frequency channel that was corrupted by the in-device interference. This is a likely scenario because the desired signal strength on the corrupted channel may sometimes be higher be reflected in the measurement reports of the new channel based on Reference Signal Received Power (RSRP) to the eNB. Hence, a ping-pong effect of being transferred back and forth between the corrupted channel and the desired channel can happen if the eNB uses RSRP reports to make handover decisions.

[0010] Other unilateral action on the part of the UE, such as simply stopping uplink communications without coordination of the eNB may cause power loop malfunctions at the eNB. Additional issues that exist in conventional LTE include a general lack of ability on the part of the UE to suggest desired configurations as an alternative to configurations that have coexistence issues. For at least these reasons, uplink coexistence issues at the UE may remain unresolved for a long time period, degrading performance and efficiency for other radios of the UE.

BRIEF SUMMARY

[0011] Additional features and advantages of the disclosure will be described below. It should be appreciated by those skilled in the art that this disclosure may be readily utilized as a basis for modifying or designing other structures for carrying out the same purposes of the present disclosure. It should also be realized by those skilled in the art that such equivalent constructions do not depart from the teachings of the disclosure as set forth in the appended claims. The novel features, which are believed to be characteristic of the disclosure, both as to its organization and method of operation, together with further objects and advantages, will be better understood from the following description when considered in connection with the accompanying figures. It is to be expressly understood, however, that each of the figures is provided for the purpose of illustration and description only and is not intended as a definition of the limits of the present disclosure.

[0012] A method of wireless communication is offered. The method includes identifying a first set of data with a first performance criteria to be supported on a first set of radio resources. The method also includes identifying a second set of data with a second performance criteria to be supported. The method further includes determining, based on an expected collision rate between the first set of radio resources and other radio resources, whether an allocation of radio resources to the first set of data and the second set of data exists to achieve the first performance criteria and second performance criteria.

[0013] An apparatus operable in a wireless communication system is offered. The apparatus includes means for identifying a first set of data with a first performance criteria to be supported on a first set of radio resources. The apparatus also includes means for identifying a second set of data with a second performance criteria to be supported. The apparatus further includes means for determining, based on an expected collision rate between the first set of radio resources and other radio resources, whether an allocation of radio resources to the first set of data and the second set of data exists to achieve the first performance criteria and second performance criteria.

[0014] A computer program product configured for wireless communication is offered. The computer program product includes a computer-readable medium having program code recorded thereon. The program code includes program code to identify a first set of data with a first performance criteria to be supported on a first set of radio resources. The program code also includes program code to identify a second set of data with a second performance criteria to be supported. The program code further includes program code to determine, based on an expected collision rate between the first set of radio resources and other radio resources, whether an allocation of radio resources to the first set of data and the second set of data exists to achieve the first performance criteria and second performance criteria.

[0015] An apparatus configured for operation in a wireless communication network is offered. The apparatus includes a memory and a processor(s) coupled to memory. The processor(s) is configured to identify a first set of data with a first performance criteria to be supported on a first set of radio resources. The processor(s) is also configured to identify a second set of data with a second performance criteria to be supported. The processor(s) is further configured to determine, based on an expected collision rate between the first set of radio resources

and other radio resources, whether an allocation of radio resources to the first set of data and the second set of data exists to achieve the first performance criteria and second performance criteria.

BRIEF DESCRIPTION OF THE DRAWINGS

[0016] The features, nature, and advantages of the present disclosure will become more apparent from the detailed description set forth below when taken in conjunction with the drawings in which like reference characters identify correspondingly throughout.

[0017] FIGURE 1 illustrates a multiple access wireless communication system according to one aspect.

[0018] FIGURE 2 is a block diagram of a communication system according to one aspect.

[0019] FIGURE 3 illustrates an exemplary frame structure in downlink Long Term Evolution (LTE) communications.

[0020] FIGURE 4 is a block diagram conceptually illustrating an exemplary frame structure in uplink Long Term Evolution (LTE) communications.

[0021] FIGURE 5 illustrates an example wireless communication environment.

[0022] FIGURE 6 is a block diagram of an example design for a multi-radio wireless device.

[0023] FIGURE 7 is graph showing respective potential collisions between seven example radios in a given decision period.

[0024] FIGURE 8 is a diagram showing operation of an example Coexistence Manager (CxM) over time.

[0025] FIGURE 9 is a block diagram of a system for providing support within a wireless communication environment for multi-radio coexistence management according to one aspect.

[0026] FIGURE 10 is a block diagram that illustrates an example connection engine/coexistence manager interface implementation.

[0027] FIGURE 11 illustrates an example throughput analysis that can be conducted to facilitate operation of a connection engine and coexistence manager in accordance with various aspects described herein.

[0028] FIGURE 12 illustrates techniques for decision unit design for a multi-radio coexistence manager platform according to one aspect of the present disclosure

DETAILED DESCRIPTION

[0029] Various aspects of the disclosure provide techniques to mitigate coexistence issues in multi-radio devices, where significant in-device coexistence problems can exist between, e.g., the LTE and Industrial Scientific and Medical (ISM) bands (e.g., for BT/WLAN). As explained above, some coexistence issues persist because an eNB is not aware of interference on the UE side that is experienced by other radios. According to one aspect, the UE declares a Radio Link Failure (RLF) and autonomously accesses a new channel or Radio Access Technology (RAT) if there is a coexistence issue on the present channel. The UE can declare a RLF in some examples for the following reasons: 1) UE reception is affected by interference due to coexistence, and 2) the UE transmitter is causing disruptive interference to another radio. The UE then sends a message indicating the coexistence issue to the eNB while reestablishing connection in the new channel or RAT. The eNB becomes aware of the coexistence issue by virtue of having received the message.

[0030] The techniques described herein can be used for various wireless communication networks such as Code Division Multiple Access (CDMA) networks, Time Division Multiple Access (TDMA) networks, Frequency Division Multiple Access (FDMA) networks, Orthogonal FDMA (OFDMA) networks, Single-Carrier FDMA (SC-FDMA) networks, etc. The terms “networks” and “systems” are often used interchangeably. A CDMA network can implement a radio technology such as Universal Terrestrial Radio Access (UTRA), cdma2000, etc. UTRA includes Wideband-CDMA (W-CDMA) and Low Chip Rate (LCR). cdma2000 covers IS-2000, IS-95 and IS-856 standards. A TDMA network can implement a radio technology such as Global System for Mobile Communications (GSM). An OFDMA network can implement a radio technology such as Evolved UTRA (E-UTRA), IEEE 802.11, IEEE

802.16, IEEE 802.20, Flash-OFDM[®], etc. UTRA, E-UTRA, and GSM are part of Universal Mobile Telecommunication System (UMTS). Long Term Evolution (LTE) is an upcoming release of UMTS that uses E-UTRA. UTRA, E-UTRA, GSM, UMTS and LTE are described in documents from an organization named “3rd Generation Partnership Project” (3GPP). cdma2000 is described in documents from an organization named “3rd Generation Partnership Project 2” (3GPP2). These various radio technologies and standards are known in the art. For clarity, certain aspects of the techniques are described below for LTE, and LTE terminology is used in portions of the description below.

[0031] Single carrier frequency division multiple access (SC-FDMA), which utilizes single carrier modulation and frequency domain equalization is a technique that can be utilized with various aspects described herein. SC-FDMA has similar performance and essentially the same overall complexity as those of an OFDMA system. SC-FDMA signal has lower peak-to-average power ratio (PAPR) because of its inherent single carrier structure. SC-FDMA has drawn great attention, especially in the uplink communications where lower PAPR greatly benefits the mobile terminal in terms of transmit power efficiency. It is currently a working assumption for an uplink multiple access scheme in 3GPP Long Term Evolution (LTE), or Evolved UTRA.

[0032] Referring to FIGURE 1, a multiple access wireless communication system according to one aspect is illustrated. An evolved Node B 100 (eNB) includes a computer 115 that has processing resources and memory resources to manage the LTE communications by allocating resources and parameters, granting/denying requests from user equipment, and/or the like. The eNB 100 also has multiple antenna groups, one group including antenna 104 and antenna 106, another group including antenna 108 and antenna 110, and an additional group including antenna 112 and antenna 114. In FIGURE 1, only two antennas are shown for each antenna group, however, more or fewer antennas can be utilized for each antenna group. A User Equipment (UE) 116 (also referred to as an Access Terminal (AT)) is in communication with antennas 112 and 114, while antennas 112 and 114 transmit information to the UE 116 over an uplink (UL) 188. The UE 122 is in communication with antennas 106 and 108, while antennas 106 and 108 transmit information to the UE 122 over a downlink (DL) 126 and receive information from the UE 122 over an uplink 124. In an FDD system, communication links 118, 120, 124 and 126 can use different

frequencies for communication. For example, the downlink 120 can use a different frequency than used by the uplink 118.

[0033] Each group of antennas and/or the area in which they are designed to communicate is often referred to as a sector of the eNB. In this aspect, respective antenna groups are designed to communicate to UEs in a sector of the areas covered by the eNB 100.

[0034] In communication over the downlinks 120 and 126, the transmitting antennas of the eNB 100 utilize beamforming to improve the signal-to-noise ratio of the uplinks for the different UEs 116 and 122. Also, an eNB using beamforming to transmit to UEs scattered randomly through its coverage causes less interference to UEs in neighboring cells than a UE transmitting through a single antenna to all its UEs.

[0035] An eNB can be a fixed station used for communicating with the terminals and can also be referred to as an access point, base station, or some other terminology. A UE can also be called an access terminal, a wireless communication device, terminal, or some other terminology.

[0036] FIGURE 2 is a block diagram of an aspect of a transmitter system 210 (also known as an eNB) and a receiver system 250 (also known as a UE) in a MIMO system 200. In some instances, both a UE and an eNB each have a transceiver that includes a transmitter system and a receiver system. At the transmitter system 210, traffic data for a number of data streams is provided from a data source 212 to a transmit (TX) data processor 214.

[0037] A MIMO system employs multiple (N_T) transmit antennas and multiple (N_R) receive antennas for data transmission. A MIMO channel formed by the N_T transmit and N_R receive antennas may be decomposed into N_S independent channels, which are also referred to as spatial channels, wherein $N_S \leq \min\{N_T, N_R\}$. Each of the N_S independent channels corresponds to a dimension. The MIMO system can provide improved performance (e.g., higher throughput and/or greater reliability) if the additional dimensionalities created by the multiple transmit and receive antennas are utilized.

[0038] A MIMO system supports time division duplex (TDD) and frequency division duplex (FDD) systems. In a TDD system, the uplink and downlink transmissions are on the same frequency region so that the reciprocity principle allows

the estimation of the downlink channel from the uplink channel. This enables the eNB to extract transmit beamforming gain on the downlink when multiple antennas are available at the eNB.

[0039] In an aspect, each data stream is transmitted over a respective transmit antenna. The TX data processor 214 formats, codes, and interleaves the traffic data for each data stream based on a particular coding scheme selected for that data stream to provide coded data.

[0040] The coded data for each data stream can be multiplexed with pilot data using OFDM techniques. The pilot data is a known data pattern processed in a known manner and can be used at the receiver system to estimate the channel response. The multiplexed pilot and coded data for each data stream is then modulated (*e.g.*, symbol mapped) based on a particular modulation scheme (*e.g.*, BPSK, QSPK, M-PSK, or M-QAM) selected for that data stream to provide modulation symbols. The data rate, coding, and modulation for each data stream can be determined by instructions performed by a processor 230 operating with a memory 232.

[0041] The modulation symbols for respective data streams are then provided to a TX MIMO processor 220, which can further process the modulation symbols (*e.g.*, for OFDM). The TX MIMO processor 220 then provides N_T modulation symbol streams to N_T transmitters (TMTR) 222a through 222t. In certain aspects, the TX MIMO processor 220 applies beamforming weights to the symbols of the data streams and to the antenna from which the symbol is being transmitted.

[0042] Each transmitter 222 receives and processes a respective symbol stream to provide one or more analog signals, and further conditions (*e.g.*, amplifies, filters, and upconverts) the analog signals to provide a modulated signal suitable for transmission over the MIMO channel. N_T modulated signals from the transmitters 222a through 222t are then transmitted from N_T antennas 224a through 224t, respectively.

[0043] At a receiver system 250, the transmitted modulated signals are received by N_R antennas 252a through 252r and the received signal from each antenna 252 is provided to a respective receiver (RCVR) 254a through 254r. Each receiver 254 conditions (*e.g.*, filters, amplifies, and downconverts) a respective received signal, digitizes the conditioned signal to provide samples, and further processes the samples to provide a corresponding "received" symbol stream.

[0044] An RX data processor 260 then receives and processes the N_R received symbol streams from N_R receivers 254 based on a particular receiver processing technique to provide N_R “detected” symbol streams. The RX data processor 260 then demodulates, deinterleaves, and decodes each detected symbol stream to recover the traffic data for the data stream. The processing by the RX data processor 260 is complementary to the processing performed by the TX MIMO processor 220 and the TX data processor 214 at the transmitter system 210.

[0045] A processor 270 (operating with a memory 272) periodically determines which pre-coding matrix to use (discussed below). The processor 270 formulates an uplink message having a matrix index portion and a rank value portion.

[0046] The uplink message can include various types of information regarding the communication link and/or the received data stream. The uplink message is then processed by a TX data processor 238, which also receives traffic data for a number of data streams from a data source 236, modulated by a modulator 280, conditioned by transmitters 254a through 254r, and transmitted back to the transmitter system 210.

[0047] At the transmitter system 210, the modulated signals from the receiver system 250 are received by antennas 224, conditioned by receivers 222, demodulated by a demodulator 240, and processed by an RX data processor 242 to extract the uplink message transmitted by the receiver system 250. The processor 230 then determines which pre-coding matrix to use for determining the beamforming weights, then processes the extracted message.

[0048] FIGURE 3 is a block diagram conceptually illustrating an exemplary frame structure in downlink Long Term Evolution (LTE) communications. The transmission timeline for the downlink may be partitioned into units of radio frames. Each radio frame may have a predetermined duration (*e.g.*, 10 milliseconds (ms)) and may be partitioned into 10 subframes with indices of 0 through 9. Each subframe may include two slots. Each radio frame may thus include 20 slots with indices of 0 through 19. Each slot may include L symbol periods, *e.g.*, 7 symbol periods for a normal cyclic prefix (as shown in FIGURE 3) or 6 symbol periods for an extended cyclic prefix. The $2L$ symbol periods in each subframe may be assigned indices of 0 through $2L-1$. The available time frequency resources may be partitioned

into resource blocks. Each resource block may cover N subcarriers (*e.g.*, 12 subcarriers) in one slot.

[0049] In LTE, an eNB may send a Primary Synchronization Signal (PSS) and a Secondary Synchronization Signal (SSS) for each cell in the eNB. The PSS and SSS may be sent in symbol periods 6 and 5, respectively, in each of subframes 0 and 5 of each radio frame with the normal cyclic prefix, as shown in FIGURE 3. The synchronization signals may be used by UEs for cell detection and acquisition. The eNB may send a Physical Broadcast Channel (PBCH) in symbol periods 0 to 3 in slot 1 of subframe 0. The PBCH may carry certain system information.

[0050] The eNB may send a Cell-specific Reference Signal (CRS) for each cell in the eNB. The CRS may be sent in symbols 0, 1, and 4 of each slot in case of the normal cyclic prefix, and in symbols 0, 1, and 3 of each slot in case of the extended cyclic prefix. The CRS may be used by UEs for coherent demodulation of physical channels, timing and frequency tracking, Radio Link Monitoring (RLM), Reference Signal Received Power (RSRP), and Reference Signal Received Quality (RSRQ) measurements, etc.

[0051] The eNB may send a Physical Control Format Indicator Channel (PCFICH) in the first symbol period of each subframe, as seen in FIGURE 3. The PCFICH may convey the number of symbol periods (M) used for control channels, where M may be equal to 1, 2 or 3 and may change from subframe to subframe. M may also be equal to 4 for a small system bandwidth, *e.g.*, with less than 10 resource blocks. In the example shown in FIGURE 3, $M=3$. The eNB may send a Physical HARQ Indicator Channel (PHICH) and a Physical Downlink Control Channel (PDCCH) in the first M symbol periods of each subframe. The PDCCH and PHICH are also included in the first three symbol periods in the example shown in FIGURE 3. The PHICH may carry information to support Hybrid Automatic Repeat Request (HARQ). The PDCCH may carry information on resource allocation for UEs and control information for downlink channels. The eNB may send a Physical Downlink Shared Channel (PDSCH) in the remaining symbol periods of each subframe. The PDSCH may carry data for UEs scheduled for data transmission on the downlink. The various signals and channels in LTE are described in 3GPP TS 36.211, entitled "Evolved Universal Terrestrial Radio Access (E-UTRA); Physical Channels and Modulation," which is publicly available.

[0052] The eNB may send the PSS, SSS and PBCH in the center 1.08 MHz of the system bandwidth used by the eNB. The eNB may send the PCFICH and PHICH across the entire system bandwidth in each symbol period in which these channels are sent. The eNB may send the PDCCH to groups of UEs in certain portions of the system bandwidth. The eNB may send the PDSCH to specific UEs in specific portions of the system bandwidth. The eNB may send the PSS, SSS, PBCH, PCFICH and PHICH in a broadcast manner to all UEs, may send the PDCCH in a unicast manner to specific UEs, and may also send the PDSCH in a unicast manner to specific UEs.

[0053] A number of resource elements may be available in each symbol period. Each resource element may cover one subcarrier in one symbol period and may be used to send one modulation symbol, which may be a real or complex value. Resource elements not used for a reference signal in each symbol period may be arranged into resource element groups (REGs). Each REG may include four resource elements in one symbol period. The PCFICH may occupy four REGs, which may be spaced approximately equally across frequency, in symbol period 0. The PHICH may occupy three REGs, which may be spread across frequency, in one or more configurable symbol periods. For example, the three REGs for the PHICH may all belong in symbol period 0 or may be spread in symbol periods 0, 1 and 2. The PDCCH may occupy 9, 18, 32 or 64 REGs, which may be selected from the available REGs, in the first M symbol periods. Only certain combinations of REGs may be allowed for the PDCCH.

[0054] A UE may know the specific REGs used for the PHICH and the PCFICH. The UE may search different combinations of REGs for the PDCCH. The number of combinations to search is typically less than the number of allowed combinations for the PDCCH. An eNB may send the PDCCH to the UE in any of the combinations that the UE will search.

[0055] FIGURE 4 is a block diagram conceptually illustrating an exemplary frame structure 300 in uplink Long Term Evolution (LTE) communications. The available Resource Blocks (RBs) for the uplink may be partitioned into a data section and a control section. The control section may be formed at the two edges of the system bandwidth and may have a configurable size. The resource blocks in the control section may be assigned to UEs for transmission of control information. The data section may include all resource blocks not included in the control section. The design

in FIGURE 4 results in the data section including contiguous subcarriers, which may allow a single UE to be assigned all of the contiguous subcarriers in the data section.

[0056] A UE may be assigned resource blocks in the control section to transmit control information to an eNB. The UE may also be assigned resource blocks in the data section to transmit data to the eNodeB. The UE may transmit control information in a Physical Uplink Control Channel (PUCCH) on the assigned resource blocks in the control section. The UE may transmit only data or both data and control information in a Physical Uplink Shared Channel (PUSCH) on the assigned resource blocks in the data section. An uplink transmission may span both slots of a subframe and may hop across frequency as shown in FIGURE 4.

[0057] The PSS, SSS, CRS, PBCH, PUCCH and PUSCH in LTE are described in 3GPP TS 36.211, entitled “Evolved Universal Terrestrial Radio Access (E-UTRA); Physical Channels and Modulation,” which is publicly available.

[0058] In an aspect, described herein are systems and methods for providing support within a wireless communication environment, such as a 3GPP LTE environment or the like, to facilitate multi-radio coexistence solutions.

[0059] Referring now to FIGURE 5, illustrated is an example wireless communication environment 500 in which various aspects described herein can function. The wireless communication environment 500 can include a wireless device 510, which can be capable of communicating with multiple communication systems. These systems can include, for example, one or more cellular systems 520 and/or 530, one or more WLAN systems 540 and/or 550, one or more wireless personal area network (WPAN) systems 560, one or more broadcast systems 570, one or more satellite positioning systems 580, other systems not shown in FIGURE 5, or any combination thereof. It should be appreciated that in the following description the terms “network” and “system” are often used interchangeably.

[0060] The cellular systems 520 and 530 can each be a CDMA, TDMA, FDMA, OFDMA, Single Carrier FDMA (SC-FDMA), or other suitable system. A CDMA system can implement a radio technology such as Universal Terrestrial Radio Access (UTRA), cdma2000, etc. UTRA includes Wideband CDMA (WCDMA) and other variants of CDMA. Moreover, cdma2000 covers IS-2000 (CDMA2000 1X), IS-95 and IS-856 (HRPD) standards. A TDMA system can implement a radio technology such as Global System for Mobile Communications (GSM), Digital Advanced Mobile

Phone System (D-AMPS), etc. An OFDMA system can implement a radio technology such as Evolved UTRA (E-UTRA), Ultra Mobile Broadband (UMB), IEEE 802.16 (WiMAX), IEEE 802.20, Flash-OFDM[®], etc. UTRA and E-UTRA are part of Universal Mobile Telecommunication System (UMTS). 3GPP Long Term Evolution (LTE) and LTE-Advanced (LTE-A) are new releases of UMTS that use E-UTRA. UTRA, E-UTRA, UMTS, LTE, LTE-A and GSM are described in documents from an organization named “3rd Generation Partnership Project” (3GPP). cdma2000 and UMB are described in documents from an organization named “3rd Generation Partnership Project 2” (3GPP2). In an aspect, the cellular system 520 can include a number of base stations 522, which can support bi-directional communication for wireless devices within their coverage. Similarly, the cellular system 530 can include a number of base stations 532 that can support bi-directional communication for wireless devices within their coverage.

[0061] WLAN systems 540 and 550 can respectively implement radio technologies such as IEEE 802.11 (WiFi), Hiperlan, etc. The WLAN system 540 can include one or more access points 542 that can support bi-directional communication. Similarly, the WLAN system 550 can include one or more access points 552 that can support bi-directional communication. The WPAN system 560 can implement a radio technology such as Bluetooth (BT), IEEE 802.15, etc. Further, the WPAN system 560 can support bi-directional communication for various devices such as wireless device 510, a headset 562, a computer 564, a mouse 566, or the like.

[0062] The broadcast system 570 can be a television (TV) broadcast system, a frequency modulation (FM) broadcast system, a digital broadcast system, etc. A digital broadcast system can implement a radio technology such as MediaFLO[™], Digital Video Broadcasting for Handhelds (DVB-H), Integrated Services Digital Broadcasting for Terrestrial Television Broadcasting (ISDB-T), or the like. Further, the broadcast system 570 can include one or more broadcast stations 572 that can support one-way communication.

[0063] The satellite positioning system 580 can be the United States Global Positioning System (GPS), the European Galileo system, the Russian GLONASS system, the Quasi-Zenith Satellite System (QZSS) over Japan, the Indian Regional Navigational Satellite System (IRNSS) over India, the Beidou system over

China, and/or any other suitable system. Further, the satellite positioning system 580 can include a number of satellites 582 that transmit signals for position determination.

[0064] In an aspect, the wireless device 510 can be stationary or mobile and can also be referred to as a user equipment (UE), a mobile station, a mobile equipment, a terminal, an access terminal, a subscriber unit, a station, etc. The wireless device 510 can be cellular phone, a personal digital assistance (PDA), a wireless modem, a handheld device, a laptop computer, a cordless phone, a wireless local loop (WLL) station, etc. In addition, a wireless device 510 can engage in two-way communication with the cellular system 520 and/or 530, the WLAN system 540 and/or 550, devices with the WPAN system 560, and/or any other suitable systems(s) and/or devices(s). The wireless device 510 can additionally or alternatively receive signals from the broadcast system 570 and/or satellite positioning system 580. In general, it can be appreciated that the wireless device 510 can communicate with any number of systems at any given moment. Also, the wireless device 510 may experience coexistence issues among various ones of its constituent radio devices that operate at the same time. Accordingly, device 510 includes a coexistence manager (CxM, not shown) that has a functional module to detect and mitigate coexistence issues, as explained further below.

[0065] Turning next to FIGURE 6, a block diagram is provided that illustrates an example design for a multi-radio wireless device 600 and may be used as an implementation of the radio 510 of FIGURE 5. As FIGURE 6 illustrates, the wireless device 600 can include N radios 620a through 620n, which can be coupled to N antennas 610a through 610n, respectively, where N can be any integer value. It should be appreciated, however, that respective radios 620 can be coupled to any number of antennas 610 and that multiple radios 620 can also share a given antenna 610.

[0066] In general, a radio 620 can be a unit that radiates or emits energy in an electromagnetic spectrum, receives energy in an electromagnetic spectrum, or generates energy that propagates via conductive means. By way of example, a radio 620 can be a unit that transmits a signal to a system or a device or a unit that receives signals from a system or device. Accordingly, it can be appreciated that a radio 620 can be utilized to support wireless communication. In another example, a radio 620 can also be a unit (*e.g.*, a screen on a computer, a circuit board, etc.) that emits noise, which can impact the performance of other radios. Accordingly, it can be further appreciated that

a radio 620 can also be a unit that emits noise and interference without supporting wireless communication.

[0067] In an aspect, respective radios 620 can support communication with one or more systems. Multiple radios 620 can additionally or alternatively be used for a given system, *e.g.*, to transmit or receive on different frequency bands (*e.g.*, cellular and PCS bands).

[0068] In another aspect, a digital processor 630 can be coupled to radios 620a through 620n and can perform various functions, such as processing for data being transmitted or received via the radios 620. The processing for each radio 620 can be dependent on the radio technology supported by that radio and can include encryption, encoding, modulation, etc., for a transmitter; demodulation, decoding, decryption, etc., for a receiver, or the like. In one example, the digital processor 630 can include a coexistence manager 640 that can control operation of the radios 620 in order to improve the performance of the wireless device 600 as generally described herein. The coexistence manager 640 can have access to a database 644, which can store information used to control the operation of the radios 620. As explained further below, the coexistence manager 640 can be adapted for a variety of techniques to decrease interference between the radios. In one example, the coexistence manager 640 requests a measurement gap pattern or DRX cycle that allows an ISM radio to communicate during periods of LTE inactivity.

[0069] For simplicity, digital processor 630 is shown in FIGURE 6 as a single processor. However, it should be appreciated that the digital processor 630 can include any number of processors, controllers, memories, etc. In one example, a controller/processor 650 can direct the operation of various units within the wireless device 600. Additionally or alternatively, a memory 652 can store program codes and data for the wireless device 600. The digital processor 630, controller/processor 650, and memory 652 can be implemented on one or more integrated circuits (ICs), application specific integrated circuits (ASICs), etc. By way of specific, non-limiting example, the digital processor 630 can be implemented on a Mobile Station Modem (MSM) ASIC.

[0070] In an aspect, the coexistence manager 640 can manage operation of respective radios 620 utilized by wireless device 600 in order to avoid interference and/or other performance degradation associated with collisions between respective

radios 620. The coexistence manager 640 may perform one or more processes, such as those illustrated in FIGURE 10. By way of further illustration, a graph 700 in FIGURE 7 represents respective potential collisions between seven example radios in a given decision period. In the example shown in graph 700, the seven radios include a WLAN transmitter (Tw), an LTE transmitter (Tl), an FM transmitter (Tf), a GSM/WCDMA transmitter (Tc/Tw), an LTE receiver (Rl), a Bluetooth receiver (Rb), and a GPS receiver (Rg). The four transmitters are represented by four nodes on the left side of the graph 700. The four receivers are represented by three nodes on the right side of the graph 700.

[0071] A potential collision between a transmitter and a receiver is represented on the graph 700 by a branch connecting the node for the transmitter and the node for the receiver. Accordingly, in the example shown in the graph 700, collisions may exist between (1) the WLAN transmitter (Tw) and the Bluetooth receiver (Rb); (2) the LTE transmitter (Tl) and the Bluetooth receiver (Rb); (3) the WLAN transmitter (Tw) and the LTE receiver (Rl); (4) the FM transmitter (Tf) and the GPS receiver (Rg); (5) a WLAN transmitter (Tw), a GSM/WCDMA transmitter (Tc/Tw), and a GPS receiver (Rg).

[0072] In one aspect, an example the coexistence manager 640 can operate in time in a manner such as that shown by diagram 800 in FIGURE 8. As diagram 800 illustrates, a timeline for coexistence manager operation can be divided into Decision Units (DUs), which can be any suitable uniform or non-uniform length (*e.g.*, 100 μ s) where notifications are processed, and a response phase (*e.g.*, 20 μ s) where commands are provided to various radios 620 and/or other operations are performed based on actions taken in the evaluation phase. In one example, the timeline shown in the diagram 800 can have a latency parameter defined by a worst case operation of the timeline, *e.g.*, the timing of a response in the case that a notification is obtained from a given radio immediately following termination of the notification phase in a given DU.

[0073] In-device coexistence problems can exist with respect to a UE between resources such as, for example, LTE and ISM bands (*e.g.*, for Bluetooth/WLAN). In current LTE implementations, any interference issues to LTE are reflected in the DL measurements (*e.g.*, Reference Signal Received Quality (RSRQ) metrics, etc.) reported by a UE and/or the DL error rate which the eNB can use to make

inter-frequency or inter-RAT handoff decisions to, *e.g.*, move LTE to a channel or RAT with no coexistence issues. However, it can be appreciated that these existing techniques will not work if, for example, the LTE UL is causing interference to Bluetooth/WLAN but the LTE DL does not see any interference from Bluetooth/WLAN. More particularly, even if the UE autonomously moves itself to another channel on the UL, the eNB can in some cases handover the UE back to the problematic channel for load balancing purposes. In any case, it can be appreciated that existing techniques do not facilitate use of the bandwidth of the problematic channel in the most efficient way.

[0074] Turning now to FIGURE 9, a block diagram of a system 900 for providing support within a wireless communication environment for multi-radio coexistence management is illustrated. In an aspect, the system 900 can include one or more UEs 910 and/or eNBs 940, which can engage in UL, DL, and/or any other suitable communication with each other and/or any other entities in the system 900. In one example, the UE 910 and/or eNB 940 can be operable to communicate using a variety of resources, including frequency channels and sub-bands, some of which can potentially be colliding with other radio resources (*e.g.*, a Bluetooth radio). Thus, the UE 910 can utilize various techniques for managing coexistence between multiple radios of the UE 910, as generally described herein.

[0075] To mitigate at least the above shortcomings, the UE 910 may utilize respective features described herein and illustrated by the system 900 to facilitate support for multi-radio coexistence within the UE 910. The channel monitoring module 912, resource coexistence analyzer 914, coexistence policy module 916, connection engine 1010, and resource allocation module 918, may, in some examples described below, be implemented as part of a coexistence manager such as the coexistence manager (CxM) 640 of FIGURE 6 or connection engine (CnE) 1010 of FIGURE 10 to implement the aspects discussed herein. The modules shown in FIGURE 9 may be used by the coexistence manager 640 to manage collisions between respective radios 620 by scheduling the respective radios 620 so as to reduce or minimize collisions to the extent possible.

[0076] Turning now to FIGURE 10, a block diagram of a system 1000 illustrates an example implementation of an interface between a connection engine (CnE) 1010 and a coexistence manager (CxM) 640. In an aspect, the connection engine

1010 may function as the responsible entity for assigning a given application to one or more sets of radio resources, herein referred to as pipe(s) 1020 or the like. As shown in system 1000, the pipes 1020 may correspond to respective radios and/or respective distinct resources of a common radio (e.g., frequencies in the case of FDM, subframes in the case of TDM, etc.). By way of specific, non-limiting example, an application assignment by the connection engine 1010 may include whether to place a file transfer on a WLAN radio or an LTE radio. The connection engine 1010 may also determine whether to activate a particular pipe, for example whether to turn on an LTE radio to operate in parallel with a Bluetooth or WLAN radio, etc. However, it should be appreciated that any suitable pipe assignment for any suitable application(s) may be performed as described herein.

[0077] In another aspect, the coexistence manager 640 may operate to allow two or more radios (e.g., associated with pipes 1020 or the like) to simultaneously operate in the presence of a collision possibility, as generally described above. Further, the coexistence manager 640 may additionally be utilized to manage pipe collisions. For example, as used herein, pipes P1 1020₁ and P2 1020₂ are considered in collision if a coexistence issue prevents at least a portion of transmission/reception events on pipes P1 and P2 from occurring simultaneously. The coexistence manager 640 may also communicate with the connection engine 1010 to inform the connection engine 1010 of potential coexistence issues between pipes.

[0078] In a further aspect, the coexistence manager 640 and the connection engine 1010 may cooperate to enhance performance of pipes 1020 by analyzing respective properties associated with the throughput of pipes 1020, based on which use of pipes 1020 can be monitored and/or otherwise managed. For example, respective entities in system 1000 can utilize instantaneous throughput $R = (R_1, R_2)$, which is the actual throughput attained at a given point for traffic T1 and T2, respectively. Further, target throughput $R_{tgt} = (R_{1,tgt}, R_{2,tgt})$ can be defined as the throughput desired for traffic T1 and T2, respectively. Target throughput may correspond to, for example, the arrival data throughput, and in some cases can be provided by the connection engine 1010. In addition, link capacity $C = (C_1, C_2)$ can be defined as the link capacity available on pipes P1 and P2, respectively.

[0079] By way of specific, non-limiting example, an application (Example) may desire a 1 Mbps throughput and be transmitted over WLAN, which has

a 54 Mbps link. Thus, based on the above definitions, the target throughput ($R_{\text{Example,tgt}}$) for the application is 1 Mbps and the capacity for the WLAN link (C_{WLAN}) is 54 Mbps. It should be appreciated, however, that capacity may in some cases drop from the full 54 Mbps due to multiple access, coexistence arbitration, etc.

[0080] By way of further example, available throughput $R_{\text{avlb}} = (R_{1,\text{avlb}}, R_{2,\text{avlb}})$ is defined as the throughput available on pipes P1 and P2 for traffic T1 and T2, respectively. In one example, available throughput may be less than capacity due to collisions on the respective pipes and/or other factors. In another example, respective collision parameters may be utilized by respective entities in system 1000. The probability of transmitting on a particular pipe is the target throughput divided by the link capacity. Thus, the probability of using the medium P1 is represented by $(R_{1,\text{tgt}} / C_1)$. Similarly, the probability of using the medium P2 is represented by $(R_{2,\text{tgt}} / C_2)$. These probabilities may determine potential collision between pipes P1 and P2. For example, α can represent the fraction of resources in collision, and can be expressed as $\alpha = (R_{1,\text{tgt}} / C_1) \cdot (R_{2,\text{tgt}} / C_2)$. Thus, the probability that the link capacity does not encounter resource collision is $1-\alpha$. Therefore, the link capacity C that operates free of collision is represented by $(1-\alpha) \cdot C$. The remaining link capacity $\alpha \cdot C$ experiences collision and thus the throughput for that link capacity is diminished by a certain percentage used to manage coexistence issues to prevent collision and achieve desired operability. Thus the throughput of pipe P1, T1, during times of no collision would be equal to $(1-\alpha) \cdot C_1$ and the throughput of of pipe P2, T2, during times of no collision would be equal to $(1-\alpha) \cdot C_2$.

[0081] During times of collision, a choice occurs as to which traffic to allow. Assuming a choice between one of two traffic streams, ξ and $(1 - \xi)$ can represent, respectively, the percentage of traffic T1 and T2 allowed in the case of a collision. The specific value of ξ may be chosen based on a desired coexistence policy. ξ may represent distribution of resources over time, power, etc. For example, if traffic T1 is given priority over traffic T2 at all instances during collision then $\xi = 1$; if traffic T2 is given priority over traffic T1 at all instances during collision then $\xi = 0$. Thus, for example, if traffic T1 operates at ξ percentage of the resources during collision, the throughput of traffic T1 during times of collision would be equal to $\xi \cdot \alpha \cdot C_1$. Similarly, if traffic T2 operates at $(1-\xi)$ percentage of the resources during collision, the throughput of traffic T2 during times of collision would be equal to $(1-\xi) \cdot \alpha \cdot C_2$. By

combining the throughput of traffic T1 at times of no collision with the throughput of traffic T1 during times of collision, the available through put of traffic T1 is determined by the equation $R_{1,avail} = ((1-\alpha) \cdot C_1) + (\xi \cdot \alpha \cdot C_1)$. Similarly, by combining the throughput of traffic T2 at times of no collision with the throughput of traffic T2 during times of collision, the available through put of traffic T2 is determined by the equation $R_{2,avail} = ((1-\alpha) \cdot C_2) + ((1-\xi) \cdot \alpha \cdot C_2)$.

[0082] Based on the above definitions, the coexistence manager 640 and the connection engine 1010 may cooperate to manage network traffic as follows. Initially, network traffic T1 can be identified, which runs over pipe P1. Subsequently, the desire to support a second set of network traffic T2 can be identified. Accordingly, the coexistence manager 640 and/or the connection engine 1010 may determine whether traffic T2 should also be supported by pipe P1, or instead if the connection engine 1010 should open a new available pipe P2 even if the connection engine 1010 has knowledge that pipes P1 and P2 collide. Subsequently, if the decision is made to open pipe P2, the coexistence manager 640 and/or the connection engine 1010 may determine how the coexistence manager 640 can manage the resources associated with pipes P1 and P2 through ξ and/or other suitable analyses to achieve target rates for traffic T1 and T2.

[0083] In an aspect, the connection engine 1010 and the coexistence manager 640 can leverage the attainable throughput region to aid in the above analysis, as illustrated by diagram 1100 in FIGURE 11. As shown in diagram 1100, it may be appreciated that based on ξ , there is a region of attainable throughput R that is less than the target throughput due to collisions. In one example, this region may be defined by the following:

[0084] $R_{1,avail} = (1 - \alpha)C_1 + \xi\alpha C_1$ (e.g., $R_{1,avail} \leq C_1$)

[0085] $R_{2,avail} = (1 - \alpha)C_2 + (1-\xi)\alpha C_2$ (e.g., $R_{2,avail} \leq C_2$)

[0086] Using the graph of FIGURE 11 as an example, if a connection engine 1010 is presented with a desired throughput that falls inside the shaded area of diagram 1100, then the connection engine 1010 knows that the throughput is supported with the given values of ξ and α . If the desired throughput falls outside the shaded area of diagram 1100, then the connection engine 1010 knows that the throughput is not-supported with the given values of ξ and α .

[0087] In another aspect, based on the above definitions and the attainable throughput region, the connection engine 1010 and/or the coexistence

manager 640 may determine whether activation of pipe P2 is desired. More particularly, based on knowledge of the target performance criteria (such as target throughput or data rates) and link capacities from the connection engine 1010 and knowledge of the collision rate from the coexistence manager 640, the possible rate contour can be drawn, based on which it can be determined whether the target rates correspond to an interior point.

[0088] In a further aspect, the coexistence manager 640 can adapt ξ and/or other suitable parameters to attain target rates for network traffic. For example, the coexistence manager 640 can initially utilize a moving window filter to estimate α . Subsequently, the coexistence manager can find the value of $\hat{\alpha}$ at each update, based on which the coexistence manager 640 can determine the value of ξ that attains a throughput as close as possible to R_{tgt} (e.g., to define an associated error function). By way of a specific, non-limiting example, such an adaptation can be performed by the coexistence manager 640 as shown below:

[0089] A cost function J is defined as $J(\xi) | \hat{\alpha} = \|R_{tgt} - R\|^2$, then

[0090] $\xi(n+1) = \xi(n) - \mu \frac{\delta(J(\xi(n)) | \hat{\alpha})}{\delta \xi}$; μ is the step size, that is:

[0091]
$$\xi(n+1) = \xi(n) - 2\mu \left[\frac{\hat{\alpha}}{(1 - (1 - \xi(n))\hat{\alpha})} (R_{1,tgt} - R_1(n))R_1(n) + \frac{\hat{\alpha}}{(1 - \xi(n)\hat{\alpha})} (R_{2,tgt} - R_2(n))R_2(n) \right]$$

[0092] Although examples above are provided using an example of two radios/traffic types, the teachings equally apply and are expandable for more than two radios/traffic types. Further, the teachings may be applied to a particular application that desires use of two (or more) pipes. The teachings above may applied for target rates on each pipe desired for use by the application.

[0093] FIGURE 12 illustrates techniques for decision unit design for a multi-radio coexistence manager platform according to one aspect of the present disclosure. As shown in block 1202, a user equipment identifies a first set of data with a first performance criteria to be supported on a first set of radio resources. As shown in block 1204, a user equipment identifies a second set of data with a second performance criteria to be supported. As shown in block 1206, a user equipment determines, based on an expected collision rate between the first set of radio resources and other radio

resources, whether an allocation of radio resources to the first set of data and the second set of data exists to achieve the first performance criteria and second performance criteria.

[0094] A UE may have means for identifying a first set of data with a first performance criteria to be supported on a first set of radio resources, means for identifying a second set of data with a second performance criteria to be supported, and means for determining, based on an expected collision rate between the first set of radio resources and other radio resources, whether an allocation of radio resources to the first set of data and the second set of data exists to achieve the first performance criteria and second performance criteria. The means may include components coexistence manager 640, connection engine 1010, coexistence policy module 916, resource allocation module 918, memory 272, processor 270, antenna 252a-r, Rx data processor 260, Tx data processor 238, data source 236, transceivers 254a-r, modulator 280, transmit data processor 238, antennas 252a-r, and/or receive data processor 260. In another aspect, the aforementioned means may be a module or any apparatus configured to perform the functions recited by the aforementioned means.

[0095] The examples above describe aspects implemented in an LTE system. However, the scope of the disclosure is not so limited. Various aspects may be adapted for use with other communication systems, such as those that employ any of a variety of communication protocols including, but not limited to, CDMA systems, TDMA systems, FDMA systems, and OFDMA systems.

[0096] It is understood that the specific order or hierarchy of steps in the processes disclosed is an example of exemplary approaches. Based upon design preferences, it is understood that the specific order or hierarchy of steps in the processes may be rearranged while remaining within the scope of the present disclosure. The accompanying method claims present elements of the various steps in a sample order, and are not meant to be limited to the specific order or hierarchy presented.

[0097] Those of skill in the art would understand that information and signals may be represented using any of a variety of different technologies and techniques. For example, data, instructions, commands, information, signals, bits, symbols, and chips that may be referenced throughout the above description may be represented by voltages, currents, electromagnetic waves, magnetic fields or particles, optical fields or particles, or any combination thereof.

[0098] Those of skill would further appreciate that the various illustrative logical blocks, modules, circuits, and algorithm steps described in connection with the aspects disclosed herein may be implemented as electronic hardware, computer software, or combinations of both. To clearly illustrate this interchangeability of hardware and software, various illustrative components, blocks, modules, circuits, and steps have been described above generally in terms of their functionality. Whether such functionality is implemented as hardware or software depends upon the particular application and design constraints imposed on the overall system. Skilled artisans may implement the described functionality in varying ways for each particular application, but such implementation decisions should not be interpreted as causing a departure from the scope of the present disclosure.

[0099] The various illustrative logical blocks, modules, and circuits described in connection with the aspects disclosed herein may be implemented or performed with a general purpose processor, a digital signal processor (DSP), an application specific integrated circuit (ASIC), a field programmable gate array (FPGA) or other programmable logic device, discrete gate or transistor logic, discrete hardware components, or any combination thereof designed to perform the functions described herein. A general purpose processor may be a microprocessor, but in the alternative, the processor may be any conventional processor, controller, microcontroller, or state machine. A processor may also be implemented as a combination of computing devices, *e.g.*, a combination of a DSP and a microprocessor, a plurality of microprocessors, one or more microprocessors in conjunction with a DSP core, or any other such configuration.

[00100] The steps of a method or algorithm described in connection with the aspects disclosed herein may be embodied directly in hardware, in a software module executed by a processor, or in a combination of the two. A software module may reside in RAM memory, flash memory, ROM memory, EPROM memory, EEPROM memory, registers, hard disk, a removable disk, a CD-ROM, or any other form of storage medium known in the art. An exemplary storage medium is coupled to the processor such the processor can read information from, and write information to, the storage medium. In the alternative, the storage medium may be integral to the processor. The processor and the storage medium may reside in an ASIC. The ASIC

may reside in a user terminal. In the alternative, the processor and the storage medium may reside as discrete components in a user terminal.

[00101] The previous description of the disclosed aspects is provided to enable any person skilled in the art to make or use the present disclosure. Various modifications to these aspects will be readily apparent to those skilled in the art, and the generic principles defined herein may be applied to other aspects without departing from the spirit or scope of the disclosure. Thus, the present disclosure is not intended to be limited to the aspects shown herein but is to be accorded the widest scope consistent with the principles and novel features disclosed herein.

CLAIMS

What is claimed is:

1. A method used in a wireless communication system, the method comprising:

identifying a first set of data with a first performance criteria to be supported on a first set of radio resources;

identifying a second set of data with a second performance criteria to be supported; and

determining, based on an expected collision rate between the first set of radio resources and other radio resources, whether an allocation of radio resources to the first set of data and the second set of data exists to achieve the first performance criteria and second performance criteria.

2. The method of claim 1 further comprising implementing the determined allocation of radio resources.

3. The method of claim 1 in which the first performance criteria and second performance criteria are target traffic rates.

4. The method of claim 1 in which the determining further comprises determining when an allocation of the first set of radio resources to the first set of data and the second set of data exists to achieve the first performance criteria and second performance criteria.

5. The method of claim 1 in which the determining further comprises determining when an allocation of more than one set of radio resources to the first set of data and the second set of data exists to achieve the first performance criteria and second performance criteria.

6. The method of claim 5 in which the determining is based on an assessment of a capacity region of the first set of radio resources, a capacity region of a second set of radio resources, the first performance criteria, and the second performance criteria.
7. The method of claim 5 further comprising activating a second set of radio resources to achieve the first performance criteria and second performance criteria.
8. The method of claim 1 in which the expected collision rate is based on at least one of a link capacity, performance criteria, and channel conditions of the first set of radio resources.
9. The method of claim 1 in which the expected collision rate is based on the first performance criteria and second performance criteria.
10. The method of claim 1 further comprising altering the allocation of radio resources based on a change in at least one of the expected collision rate, the first performance criteria and the second performance criteria, the altering achieving the first performance criteria, including when altered, and second performance criteria, including when altered.
11. The method of claim 1 in which the allocation is based on performance criteria for the radio resources to be allocated.
12. The method of claim 1 in which the first set of radio resources comprises at least one of a radio access technology, a set of frequencies, and a set of subframes.
13. The method of claim 1 in which identifying performance criteria of the first set of data and the identifying performance criteria of the second set of data are performed by a connection engine and the determining is performed by a coexistence manager.

14. An apparatus operable in a wireless communication system, the apparatus comprising:

means for identifying a first set of data with a first performance criteria to be supported on a first set of radio resources;

means for identifying a second set of data with a second performance criteria to be supported; and

means for determining, based on an expected collision rate between the first set of radio resources and other radio resources, whether an allocation of radio resources to the first set of data and the second set of data exists to achieve the first performance criteria and second performance criteria.

15. A computer program product configured for wireless communication, the computer program product comprising:

a computer-readable medium having non-transitory program code recorded thereon, the program code comprising:

program code to identify a first set of data with a first performance criteria to be supported on a first set of radio resources;

program code to identify a second set of data with a second performance criteria to be supported; and

program code to determine, based on an expected collision rate between the first set of radio resources and other radio resources, whether an allocation of radio resources to the first set of data and the second set of data exists to achieve the first performance criteria and second performance criteria.

16. An apparatus configured for operation in a wireless communication network, the apparatus comprising:

a memory; and

at least one processor coupled to the memory, the at least one processor being configured:

to identify a first set of data with a first performance criteria to be supported on a first set of radio resources;

to identify a second set of data with a second performance criteria to be supported; and

to determine, based on an expected collision rate between the first set of radio resources and other radio resources, whether an allocation of radio resources to the first set of data and the second set of data exists to achieve the first performance criteria and second performance criteria.

17. The apparatus of claim 16 in which the at least one processor is further configured to implement the determined allocation of radio resources.

18. The apparatus of claim 16 in which the first performance criteria and second performance criteria are target traffic rates.

19. The apparatus of claim 16 in which the at least one processor is further configured to determine by determining when an allocation of the first set of radio resources to the first set of data and the second set of data exists to achieve the first performance criteria and second performance criteria.

20. The apparatus of claim 16 in which the at least one processor is further configured to determine by determining when an allocation of more than one set of radio resources to the first set of data and the second set of data exists to achieve the first performance criteria and second performance criteria.

21. The apparatus of claim 20 in which the at least one processor being configured to determine is based on an assessment of a capacity region of the first set of radio resources, a capacity region of a second set of radio resources, the first performance criteria, and the second performance criteria.

22. The apparatus of claim 20 in which the at least one processor is further configured to activate a second set of radio resources to achieve the first performance criteria and second performance criteria.

23. The apparatus of claim 16 in which the expected collision rate is based on at least one of a link capacity, performance criteria, and channel conditions of the first set of radio resources.

24. The apparatus of claim 16 in which the expected collision rate is based on the first performance criteria and second performance criteria.

25. The apparatus of claim 16 in which the at least one processor is further configured to alter the allocation of radio resources based on a change in at least one of the expected collision rate, the first performance criteria and the second performance criteria, the altering achieving the first performance criteria, including when altered, and second performance criteria, including when altered.

26. The apparatus of claim 16 in which the allocation is based on performance criteria for the radio resources to be allocated.

27. The apparatus of claim 16 in which the first set of radio resources comprises at least one of a radio access technology, a set of frequencies, and a set of subframes.

28. The apparatus of claim 16 in which the at least one processor being configured to identify performance criteria of the first set of data and in which the at least one processor being configured to identify performance criteria of the second set of data within a connection engine and the at least one processor being configured to determine within a coexistence manager.

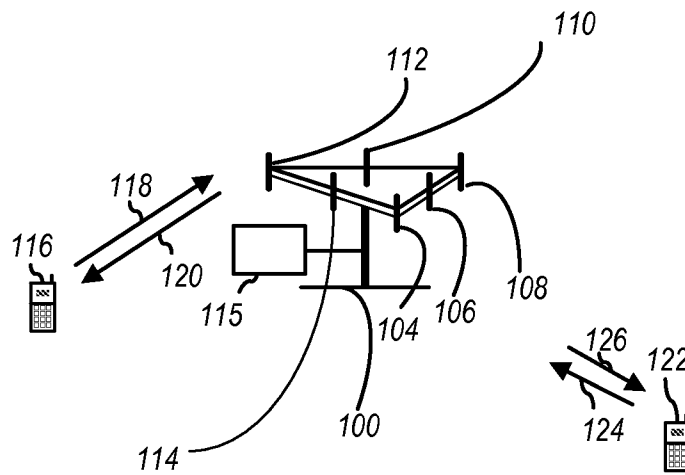

FIG. 1

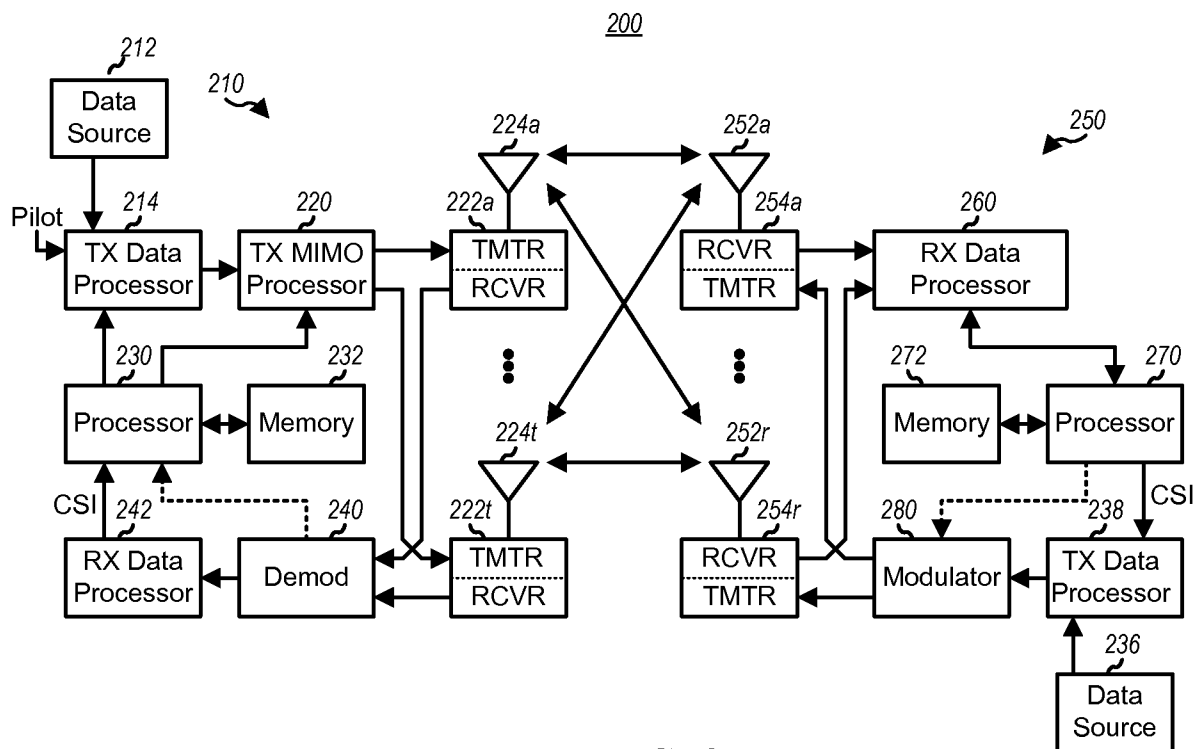

FIG. 2

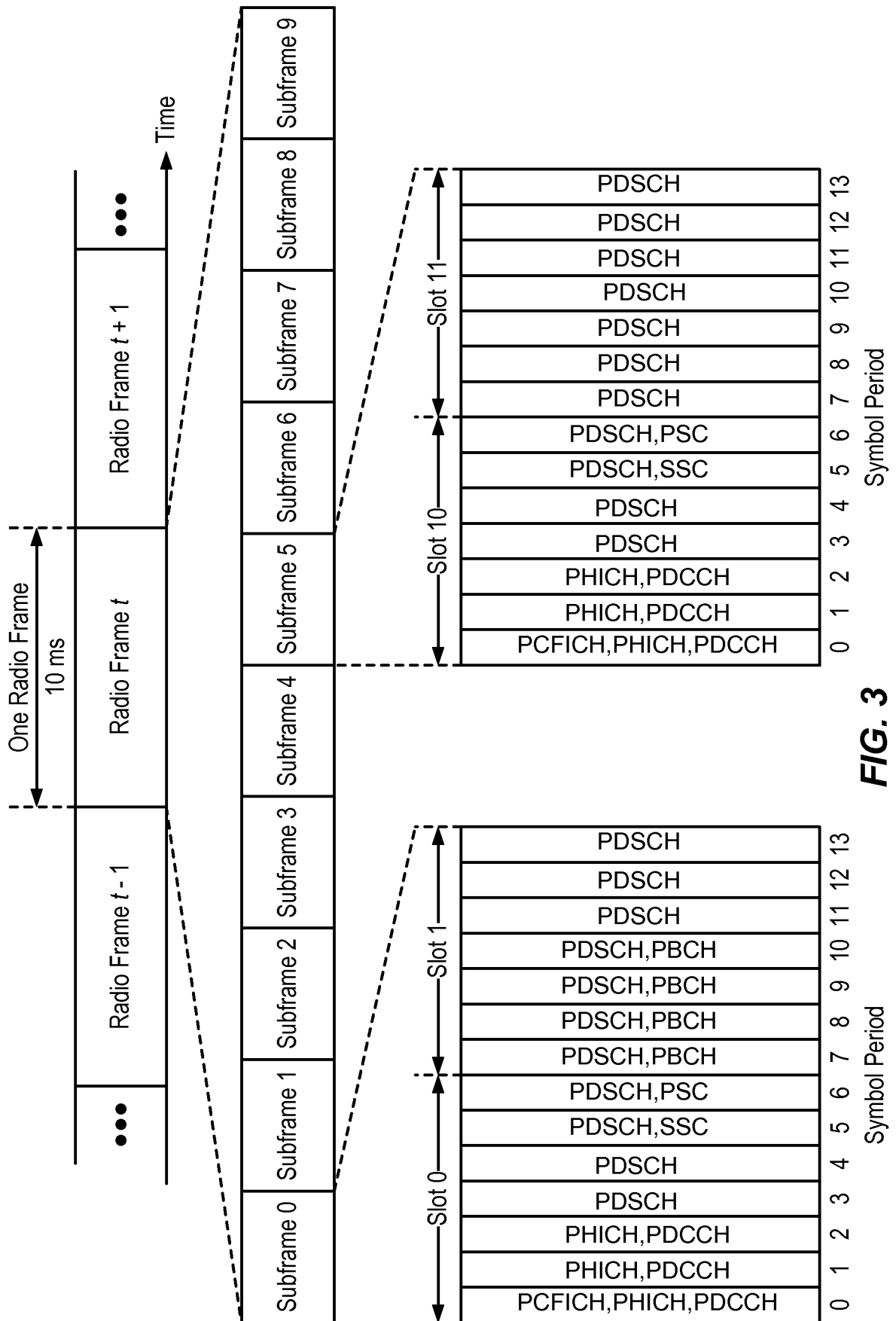

FIG. 3

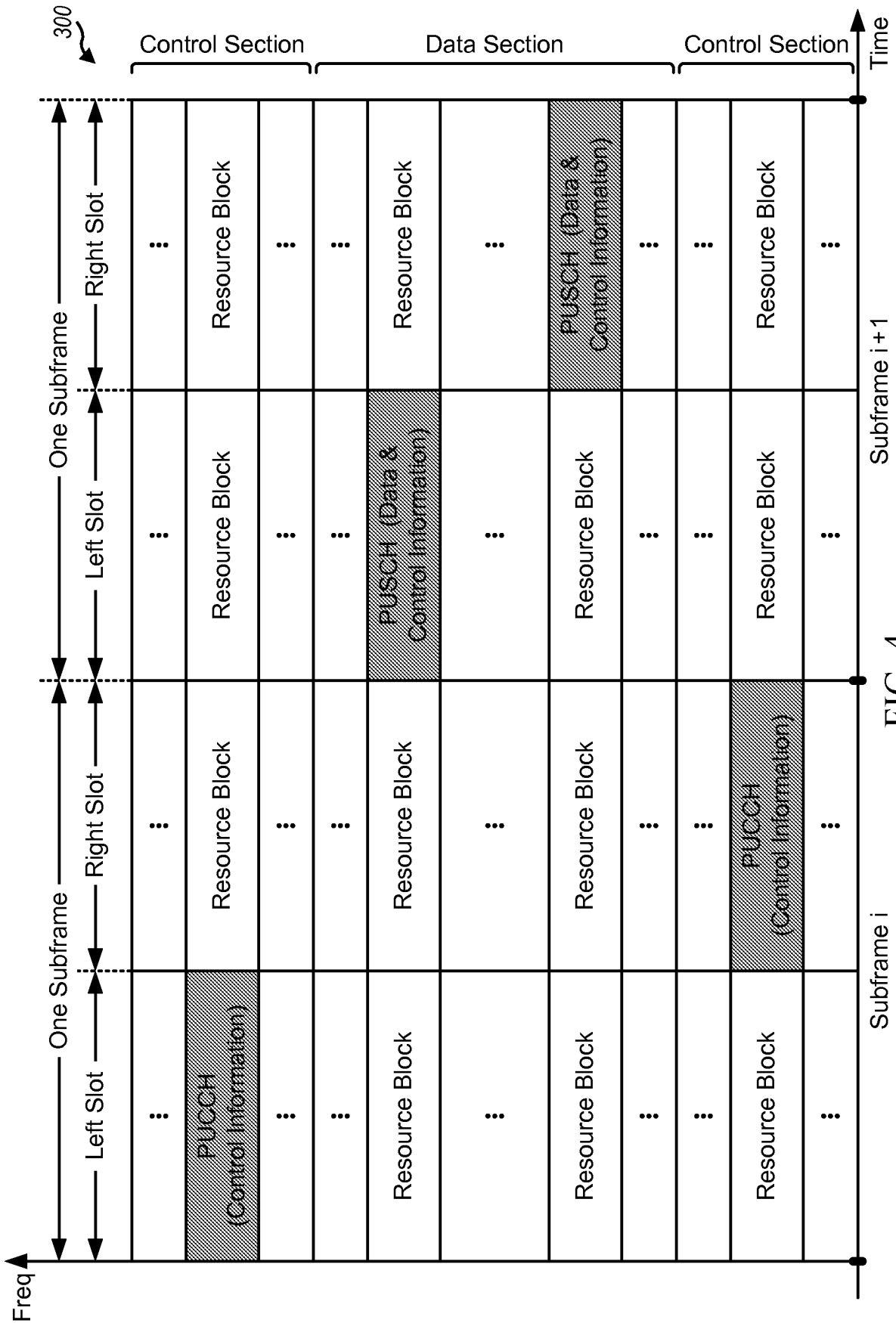

FIG. 4

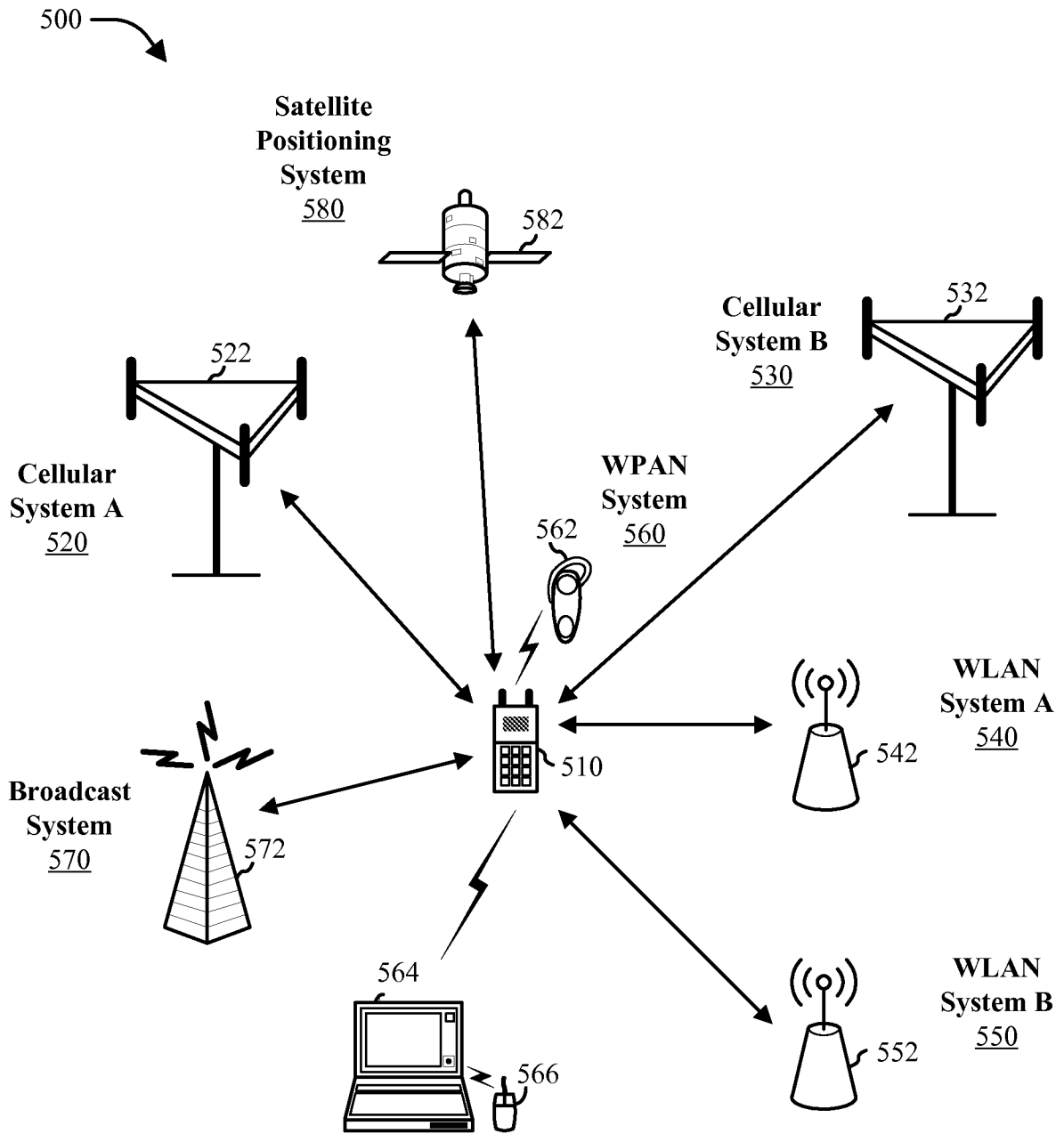

FIG. 5

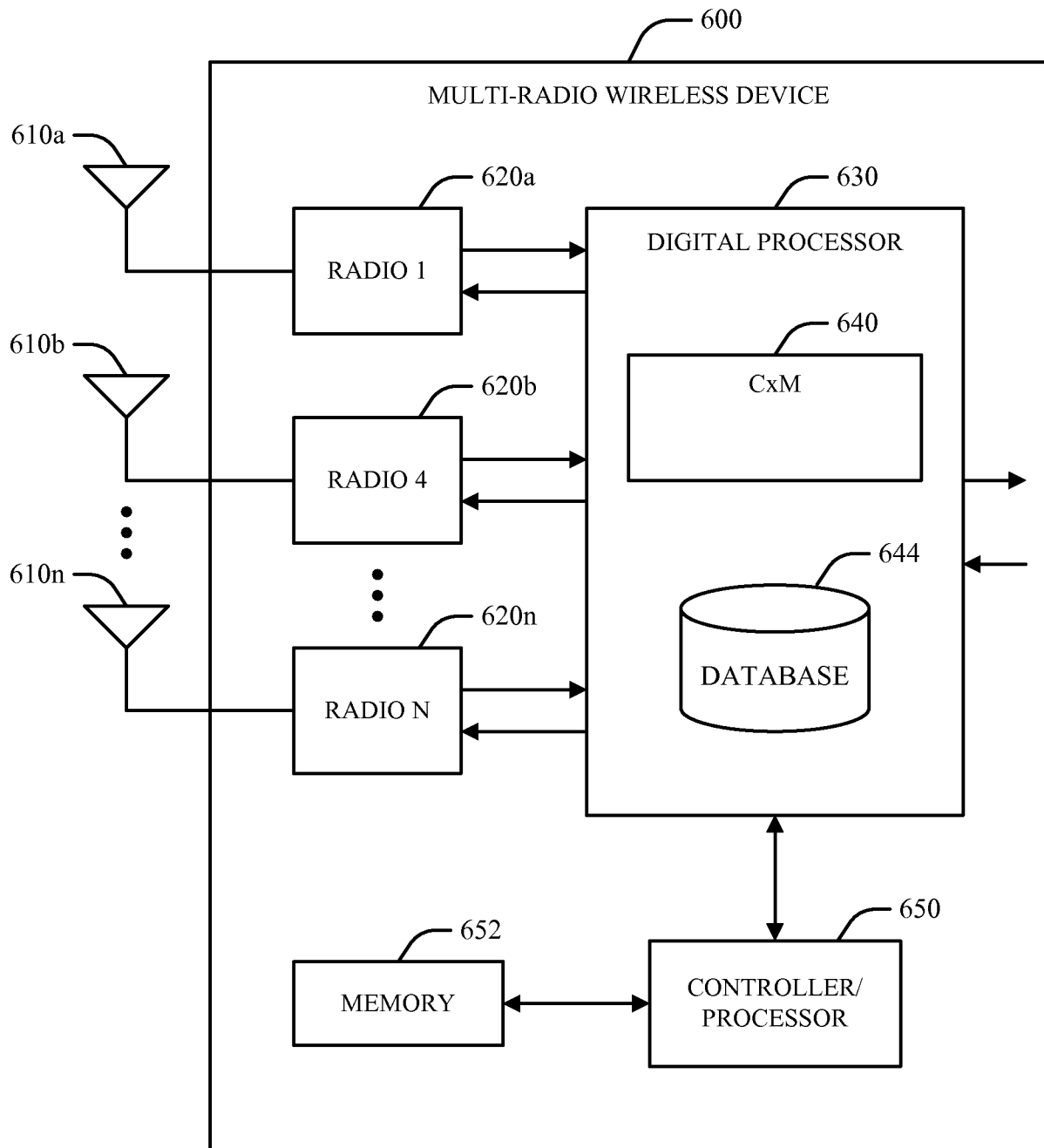

FIG. 6

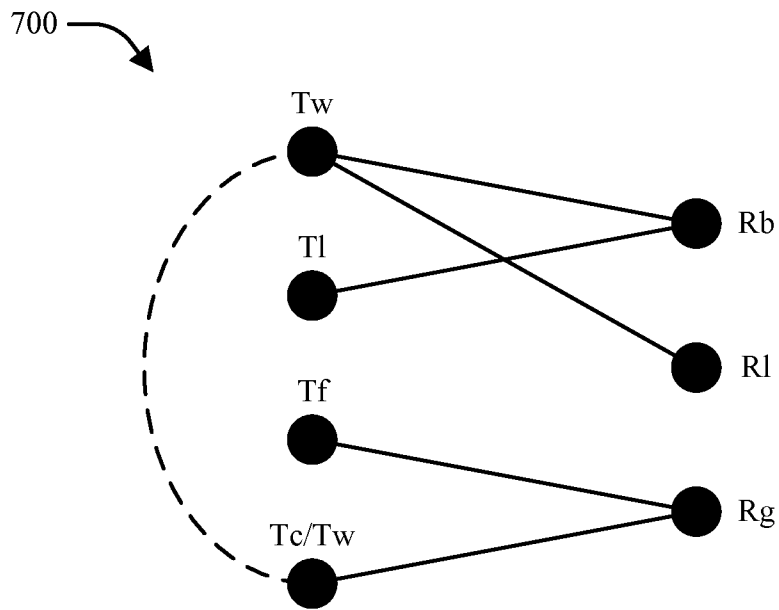

FIG. 7

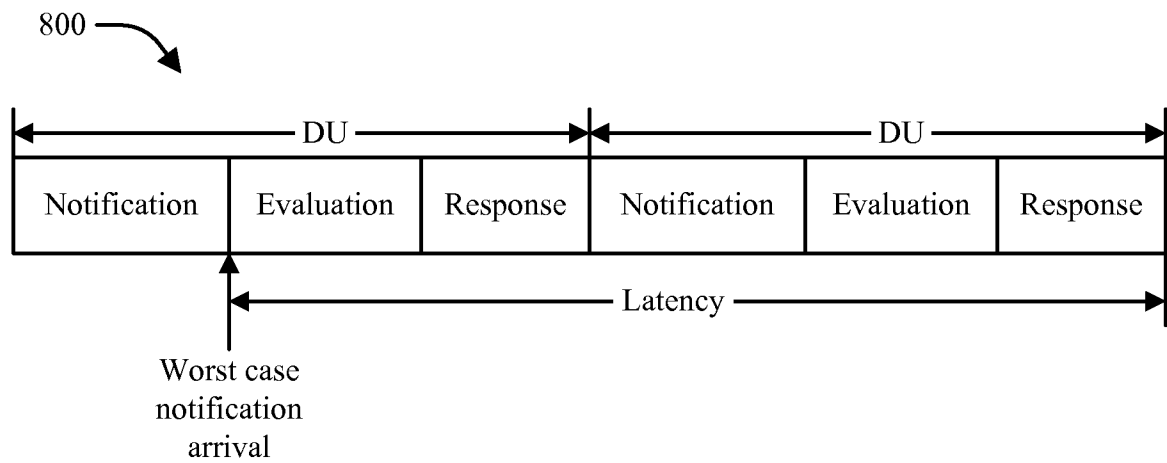

FIG. 8

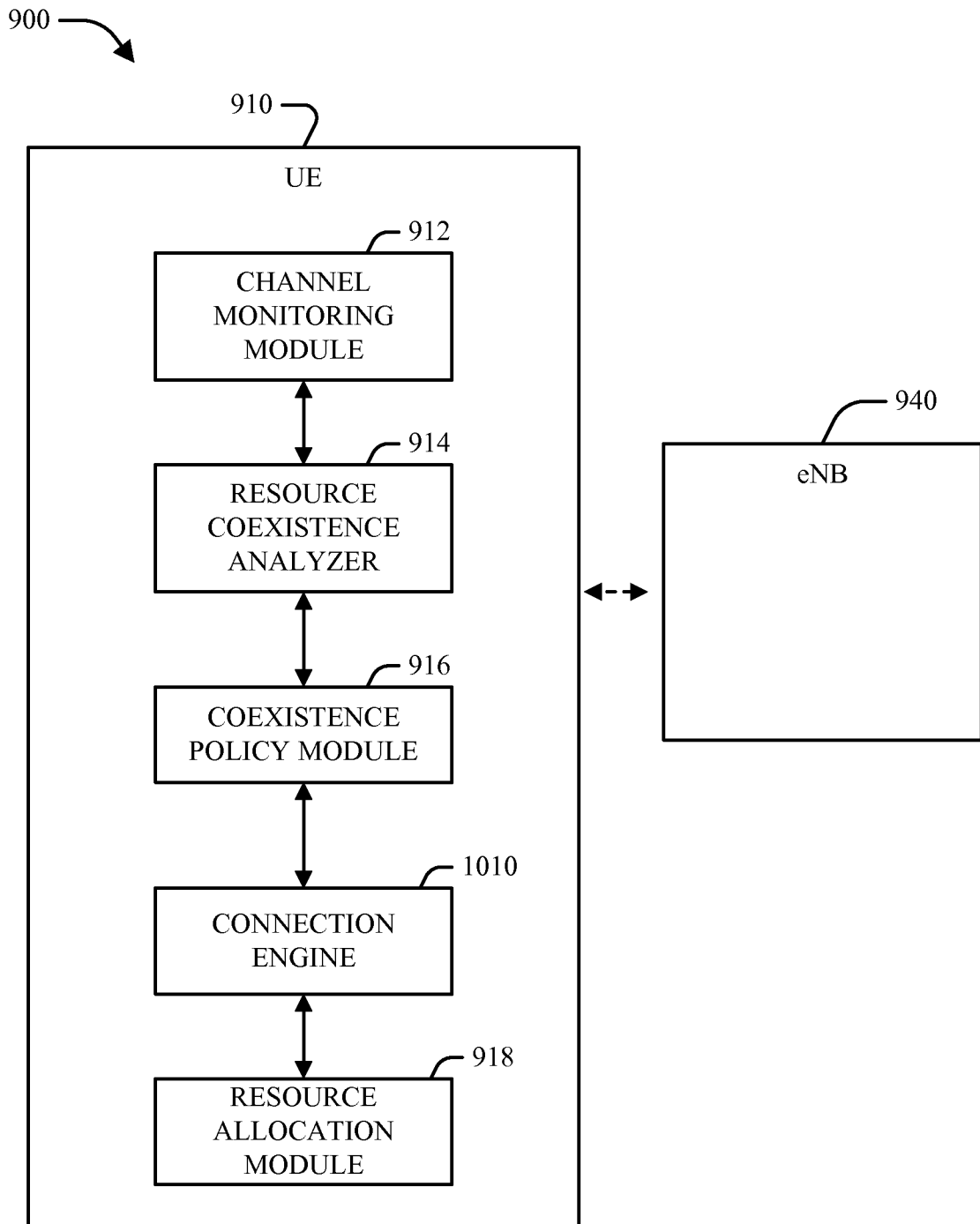

FIG. 9

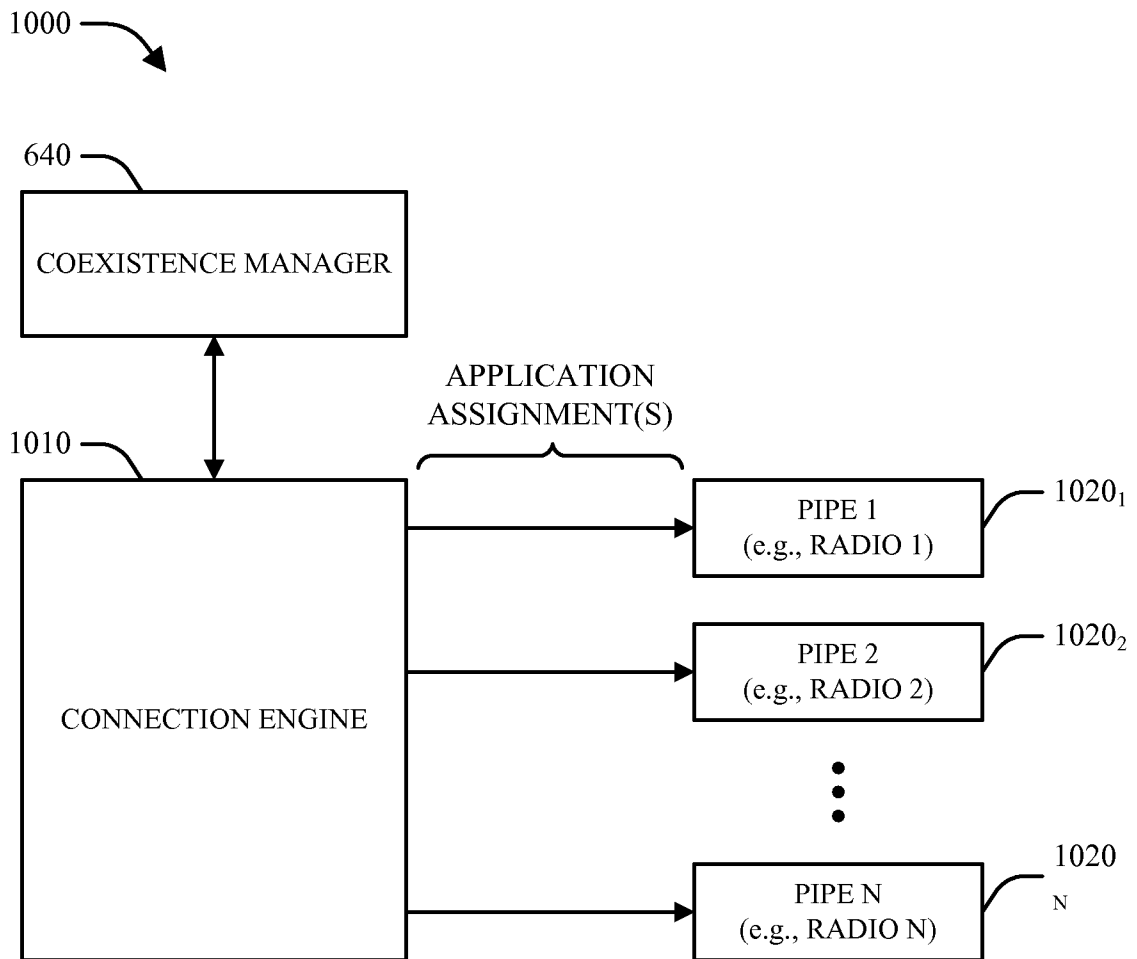

Fig. 10

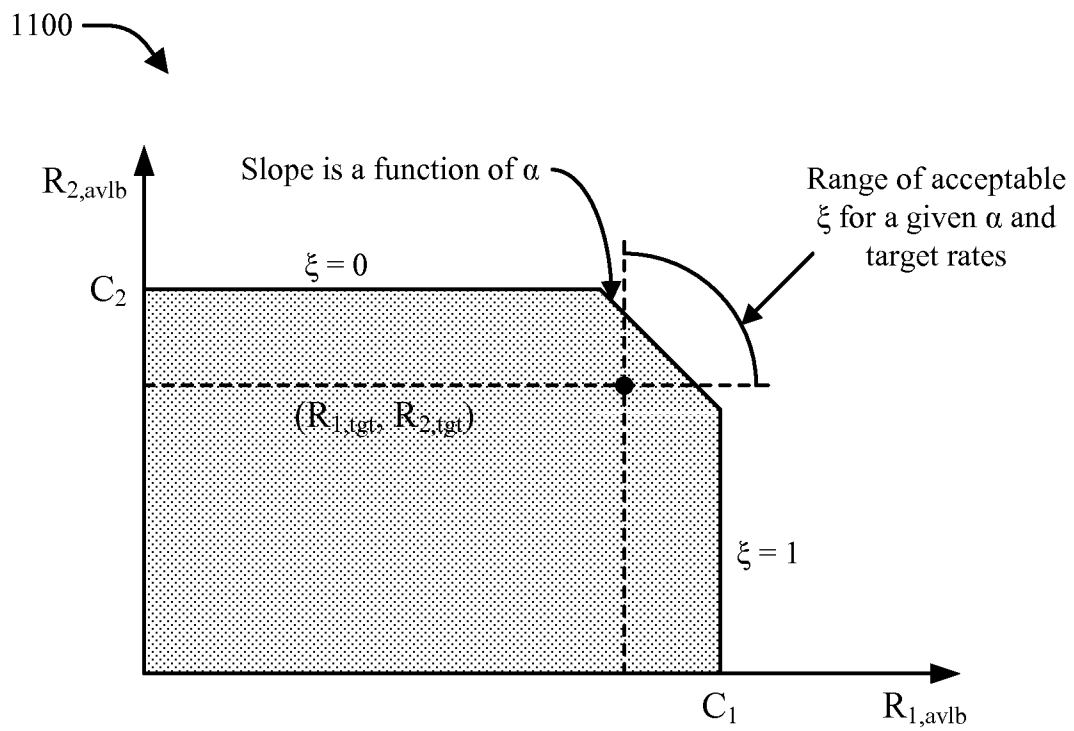

Fig. 11

10/10

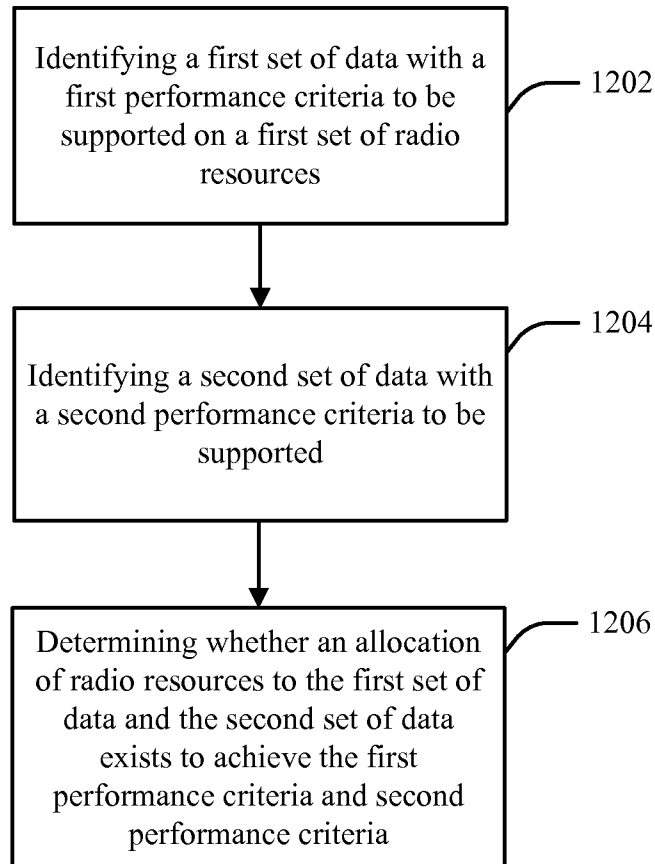

FIG. 12

INTERNATIONAL SEARCH REPORT

International application No
PCT/US2011/030614

A. CLASSIFICATION OF SUBJECT MATTER INV. H04W72/12 H04W16/14 ADD.		
According to International Patent Classification (IPC) or to both national classification and IPC		
B. FIELDS SEARCHED Minimum documentation searched (classification system followed by classification symbols) H04W		
Documentation searched other than minimum documentation to the extent that such documents are included in the fields searched		
Electronic data base consulted during the international search (name of data base and, where practical, search terms used) EPO-Internal, PAJ, WPI Data		
C. DOCUMENTS CONSIDERED TO BE RELEVANT		
Category*	Citation of document, with indication, where appropriate, of the relevant passages	Relevant to claim No.
X	US 2007/206631 A1 (PARTS ULO [FI] ET AL) 6 September 2007 (2007-09-06) page 4, paragraph 39 - paragraph 45 -----	1-28
X	EP 1 589 781 A2 (MICROSOFT CORP [US]) 26 October 2005 (2005-10-26) page 7, paragraph 31 - paragraph 33 page 8, paragraph 39 - page 9, paragraph 45 -----	1-28
X	US 2008/233875 A1 (DESAI PRASANNA [US] ET AL) 25 September 2008 (2008-09-25) page 1, paragraph 22 - page 2, paragraph 24 page 3, paragraphs 42,43 page 4, paragraph 47 page 6, paragraph 77 -----	1-28
	-/--	
<input checked="" type="checkbox"/> Further documents are listed in the continuation of Box C. <input checked="" type="checkbox"/> See patent family annex.		
* Special categories of cited documents : "A" document defining the general state of the art which is not considered to be of particular relevance "E" earlier document but published on or after the international filing date "L" document which may throw doubts on priority claim(s) or which is cited to establish the publication date of another citation or other special reason (as specified) "O" document referring to an oral disclosure, use, exhibition or other means "P" document published prior to the international filing date but later than the priority date claimed "T" later document published after the international filing date or priority date and not in conflict with the application but cited to understand the principle or theory underlying the invention "X" document of particular relevance; the claimed invention cannot be considered novel or cannot be considered to involve an inventive step when the document is taken alone "Y" document of particular relevance; the claimed invention cannot be considered to involve an inventive step when the document is combined with one or more other such documents, such combination being obvious to a person skilled in the art. "&" document member of the same patent family		
Date of the actual completion of the international search 7 July 2011		Date of mailing of the international search report 13/07/2011
Name and mailing address of the ISA/ European Patent Office, P.B. 5818 Patentlaan 2 NL - 2280 HV Rijswijk Tel. (+31-70) 340-2040, Fax: (+31-70) 340-3016		Authorized officer García, Montse

INTERNATIONAL SEARCH REPORT

International application No
PCT/US2011/030614

C(Continuation). DOCUMENTS CONSIDERED TO BE RELEVANT		
Category*	Citation of document, with indication, where appropriate, of the relevant passages	Relevant to claim No.
X	EP 1 489 788 A2 (MICROSOFT CORP [US]) 22 December 2004 (2004-12-22) abstract column 1, paragraph 4 - column 5, paragraph 17 -----	1-28

INTERNATIONAL SEARCH REPORT

Information on patent family members

International application No PCT/US2011/030614

Patent document cited in search report	Publication date	Patent family member(s)	Publication date
US 2007206631 A1	06-09-2007	EP 2087614 A1 WO 2008053082 A1	12-08-2009 08-05-2008
EP 1589781 A2	26-10-2005	CN 1716900 A JP 2005328520 A KR 20060047429 A US 2005239497 A1	04-01-2006 24-11-2005 18-05-2006 27-10-2005
US 2008233875 A1	25-09-2008	NONE	
EP 1489788 A2	22-12-2004	CN 1630294 A JP 4512426 B2 JP 2005012815 A KR 20040111157 A US 2004259589 A1	22-06-2005 28-07-2010 13-01-2005 31-12-2004 23-12-2004