

(21) Application No 9402326.4

(22) Date of Filing 07.02.1994

(30) Priority Data

(31) 9302469 (32) 09.02.1993 (33) GB

(71) Applicant(s)

Numatic International Limited

(Incorporated in the United Kingdom)

**Broadwindsor Road, BEAMINSTER, Dorset, DT8 3PR,
United Kingdom**

(72) Inventor(s)

**Christopher Robert Duncan
Michael Edward Gales**

(74) Agent and/or Address for Service

**F J Cleveland & Co
40-43 Chancery Lane, LONDON, WC2A 1JQ,
United Kingdom**

(51) INT CL⁵

A47L 11/30

(52) UK CL (Edition M)

**A4F FD12 FEA13 FEF12 FEX FFB101 FFB202 FFB203
FHC13**

(56) Documents Cited

EP 0185310 A US 4466155 A US 3996640 A

(58) Field of Search

**UK CL (Edition M) A4F
INT CL⁵ A47L 7/00 11/20 11/29 11/30
ONLINE DATABASES : WPI**

(54) Floor cleaning apparatus

(57) Floor cleaning apparatus in which water is deposited on the floor during scrubbing, and is sucked up by vacuum means attached to the machine comprises a dispensing reservoir 40 and one or more separate collection reservoirs 60 and arrangement returning liquid under the influence of gravity via valve means 75 and possibly a filter (275, Fig. 7) from the collection reservoir back into the dispensing reservoir so that water or cleaning fluid can be recycled. Single bin collection or multi-bin collection may be used; in the case of the latter, the weight of the collected water is sufficiently small to facilitate removal. There may be means of bias eg a spring loaded plunger (212, Fig. 8) controlling the workhead to ensure that the machine is readily moveable in a straight line and does not significantly deviate from side to side. Filling means may be provided (276, Fig. 7) to enable the lower dispensing container to be filled without removing the upper collecting container.

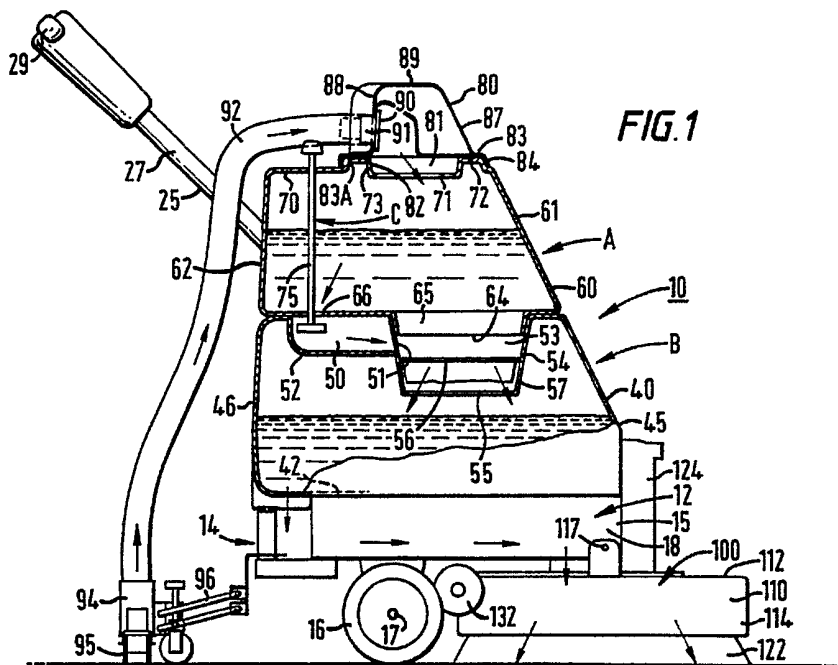

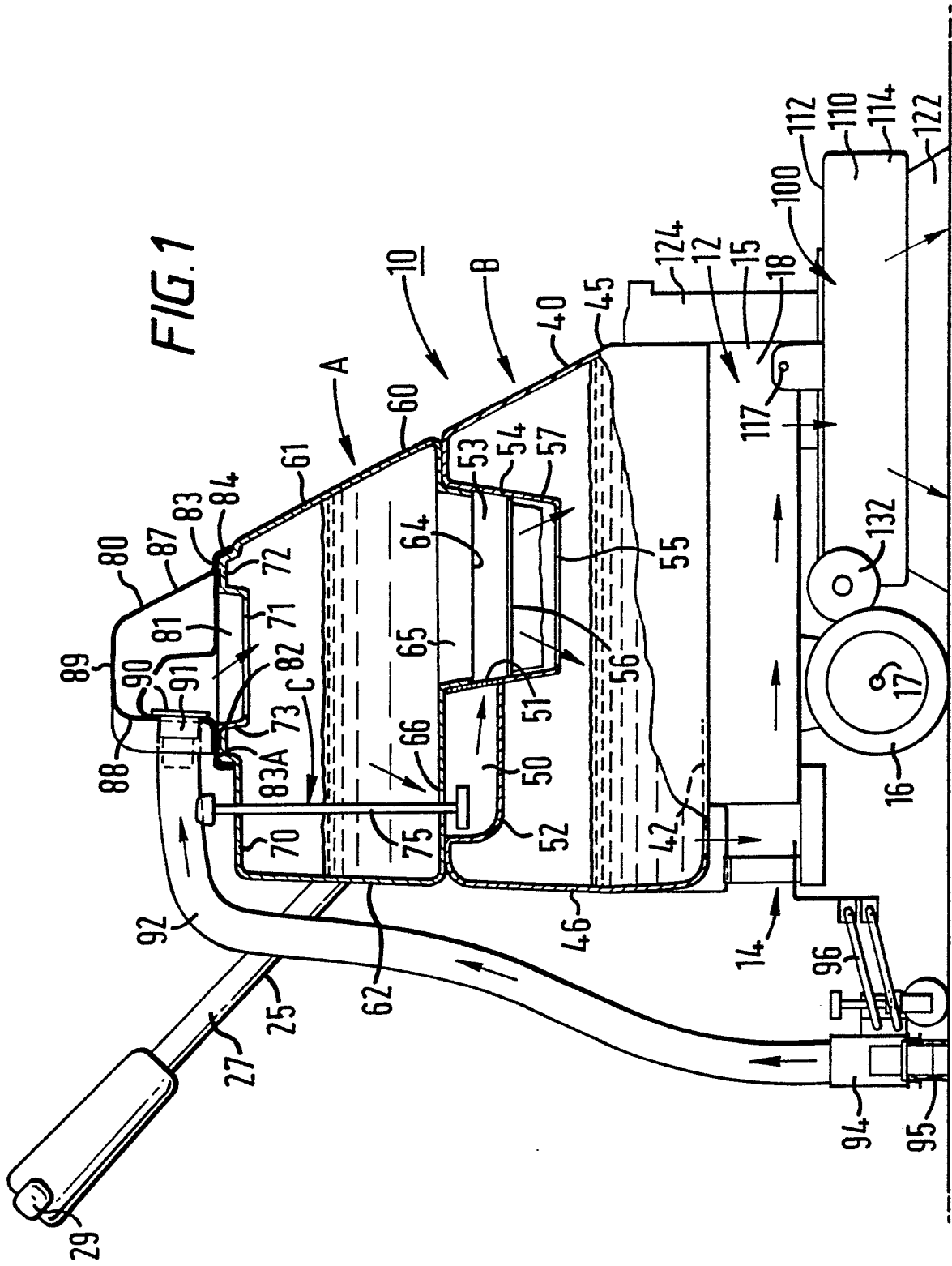

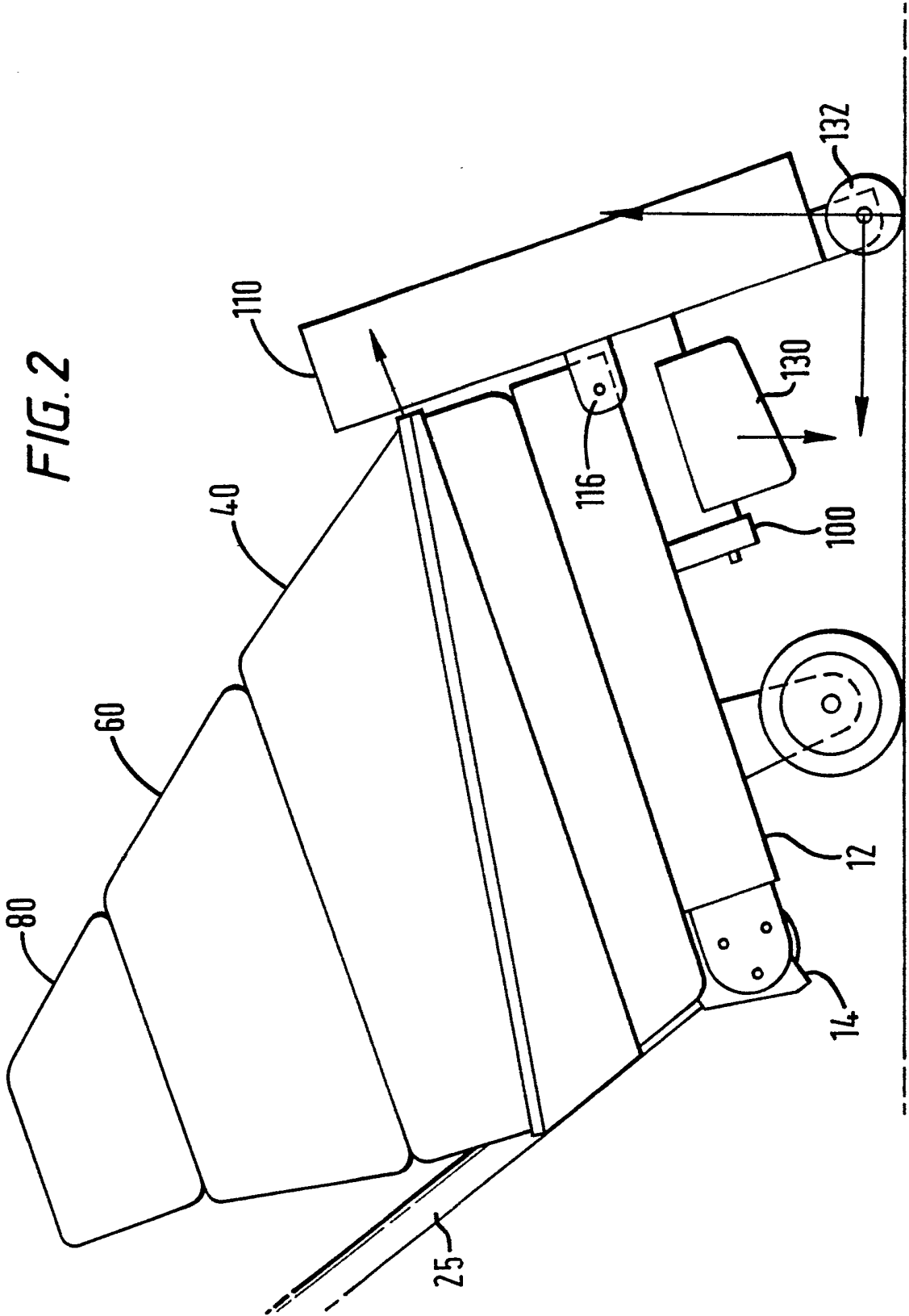

FIG. 3

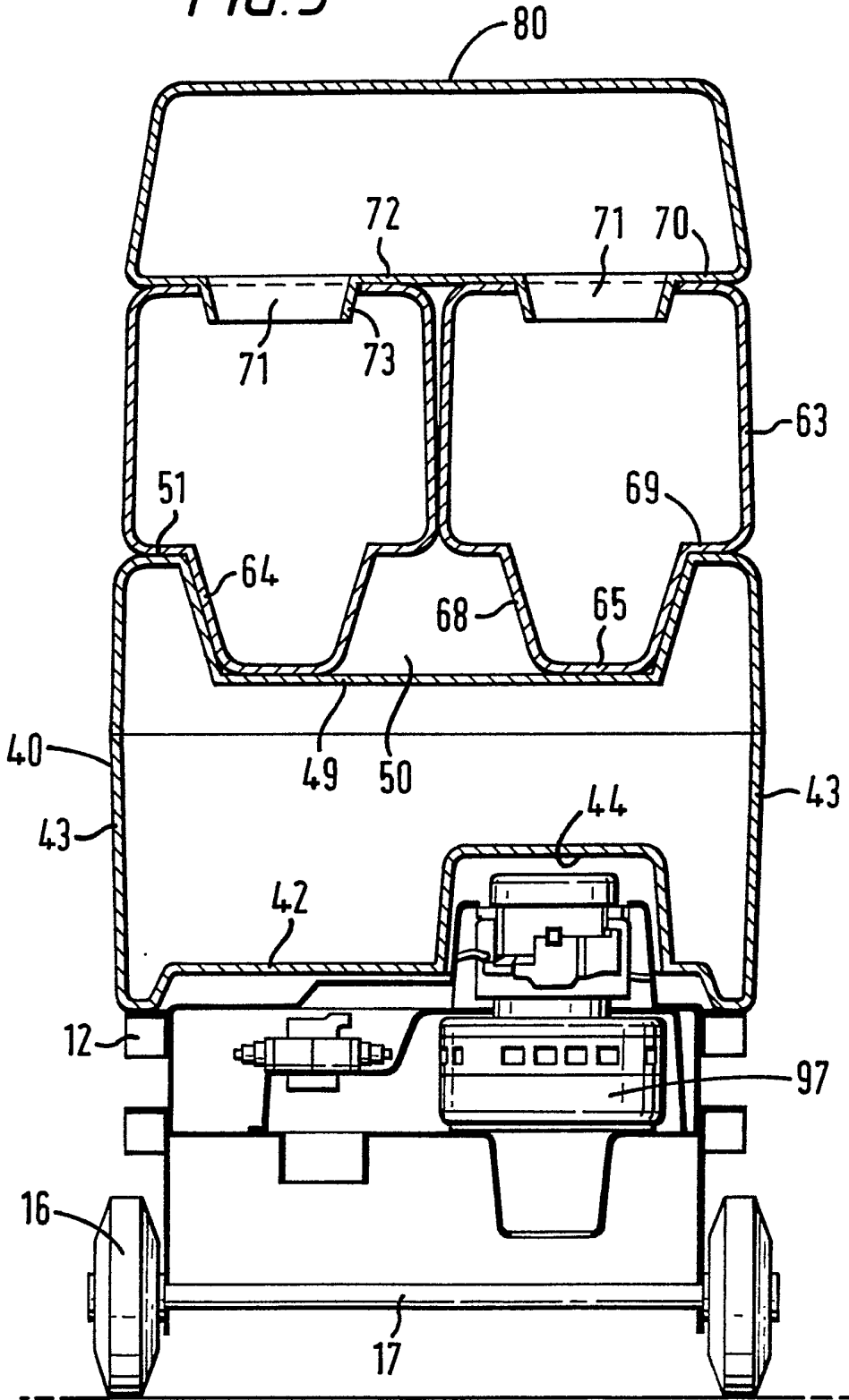

FIG. 4

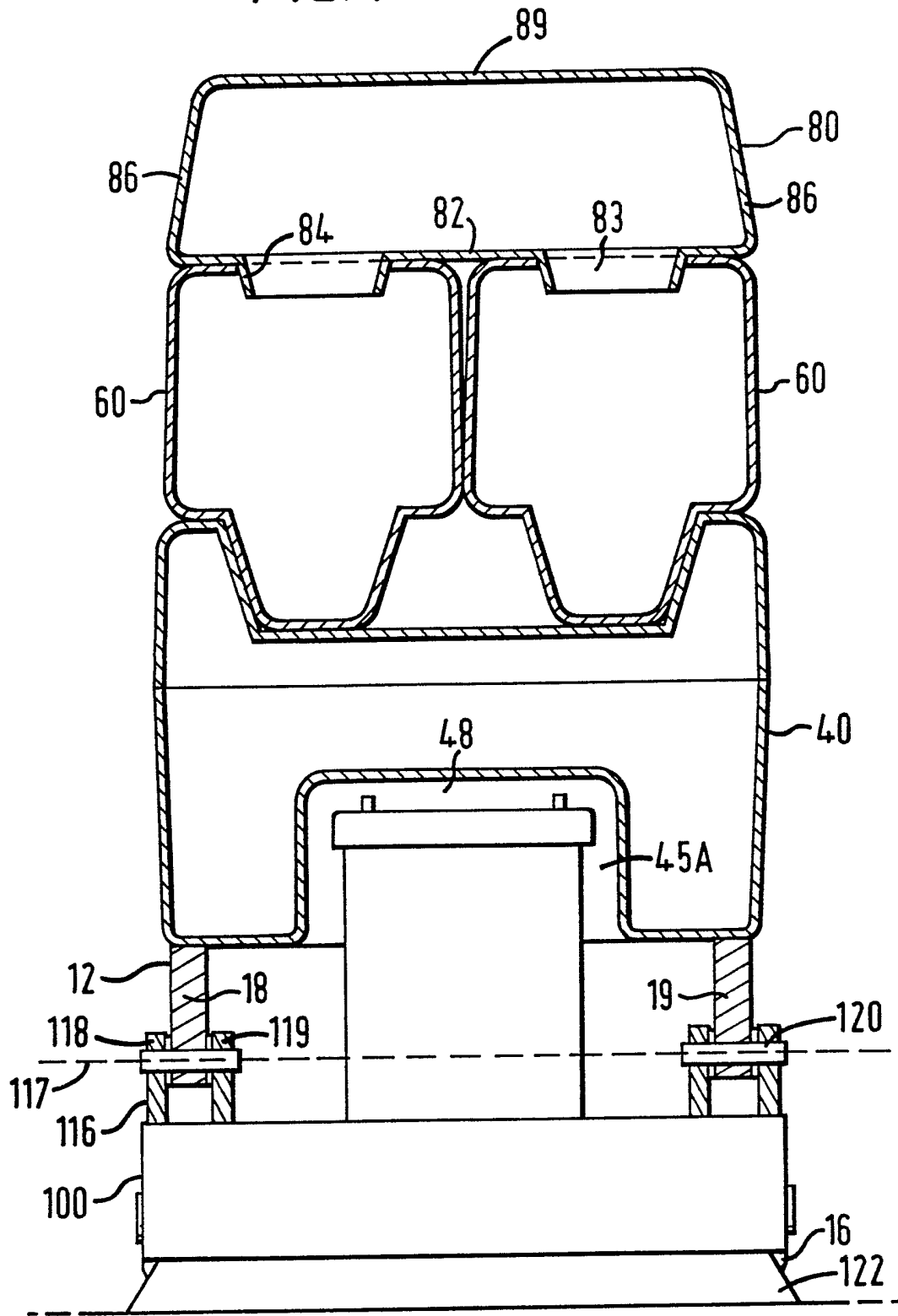

FIG. 6

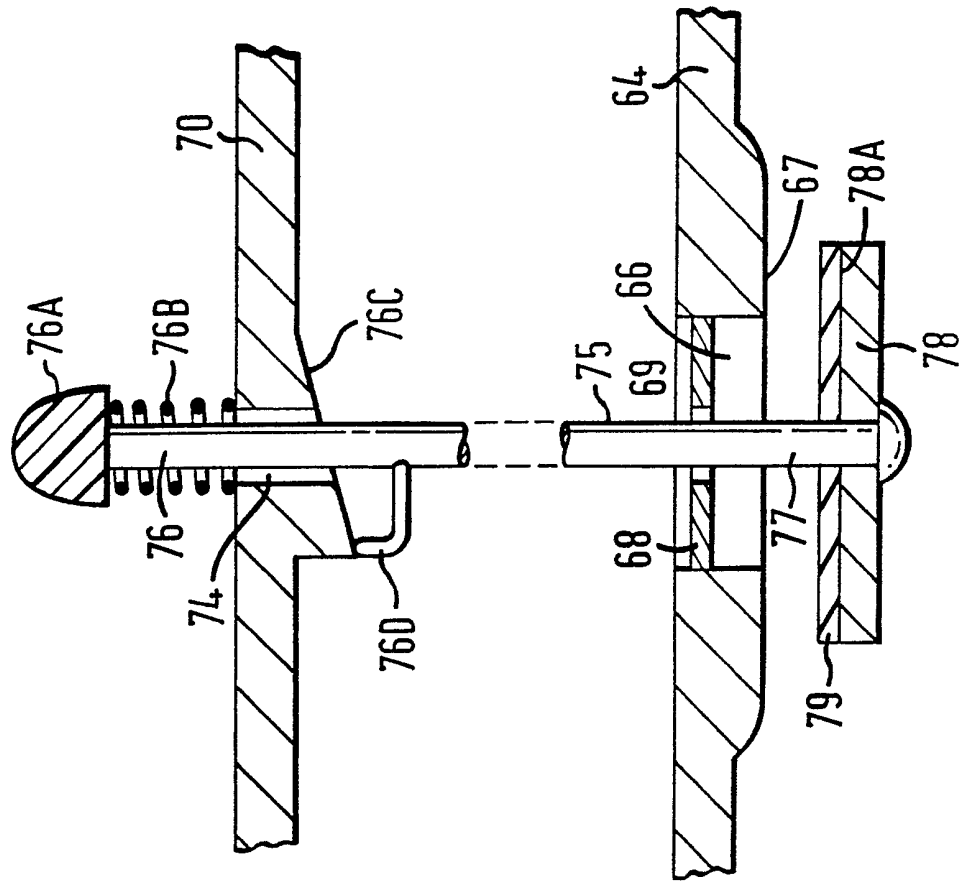

FIG. 5

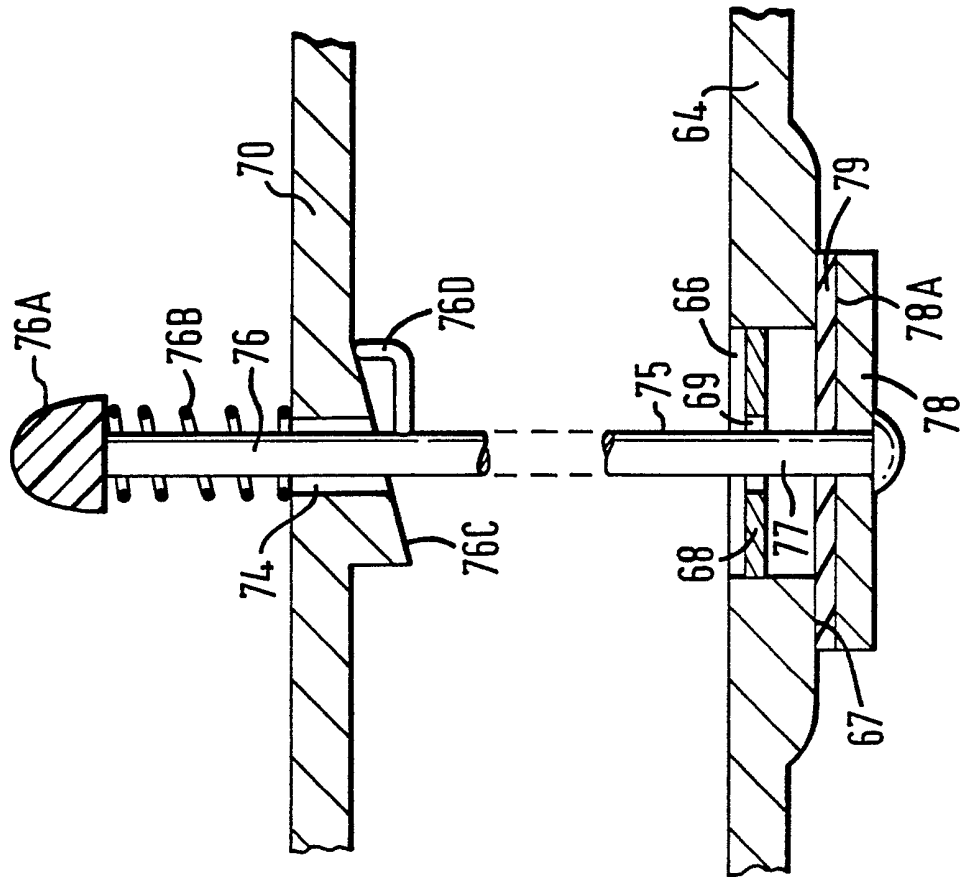

FIG. 7

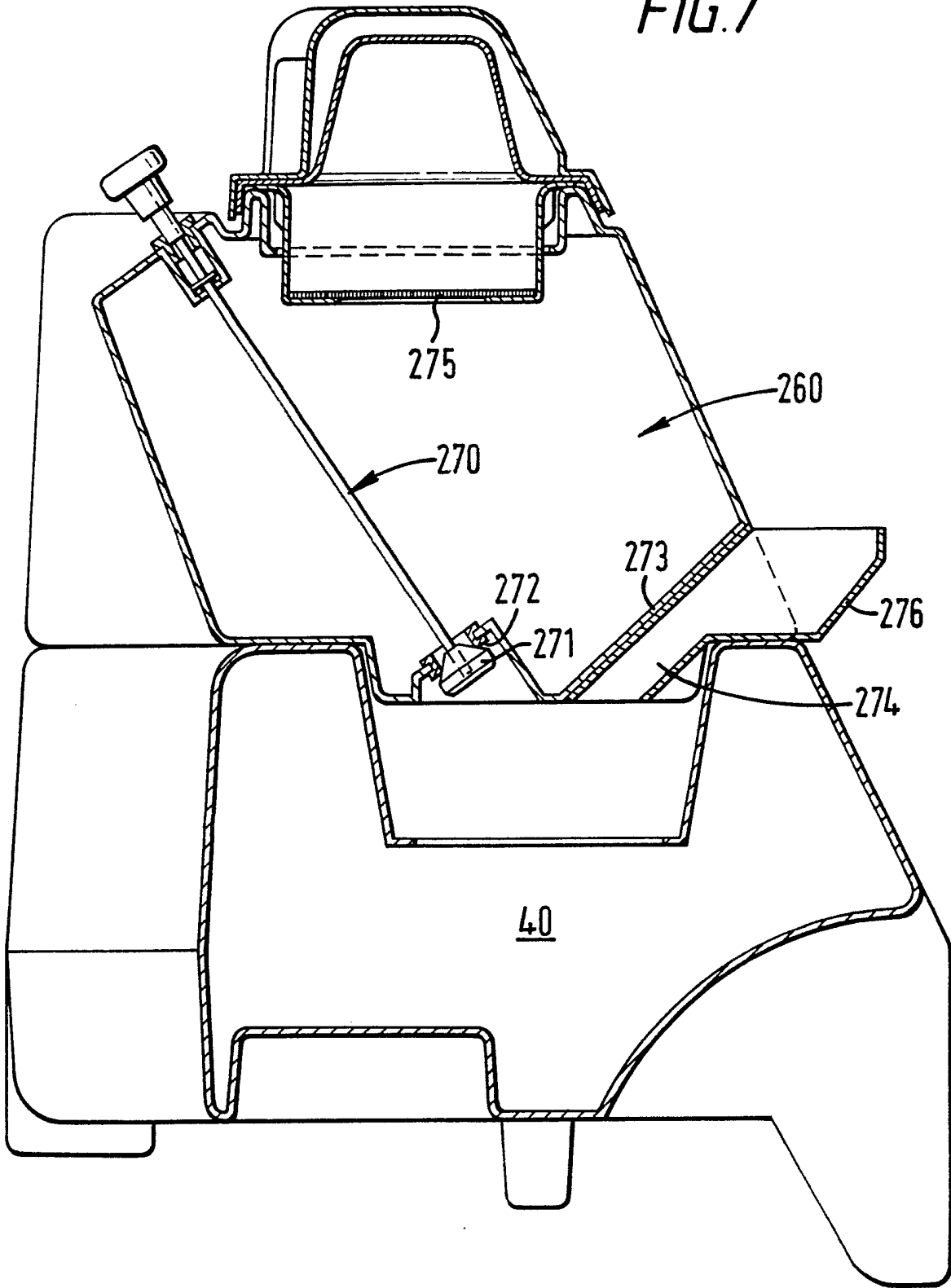
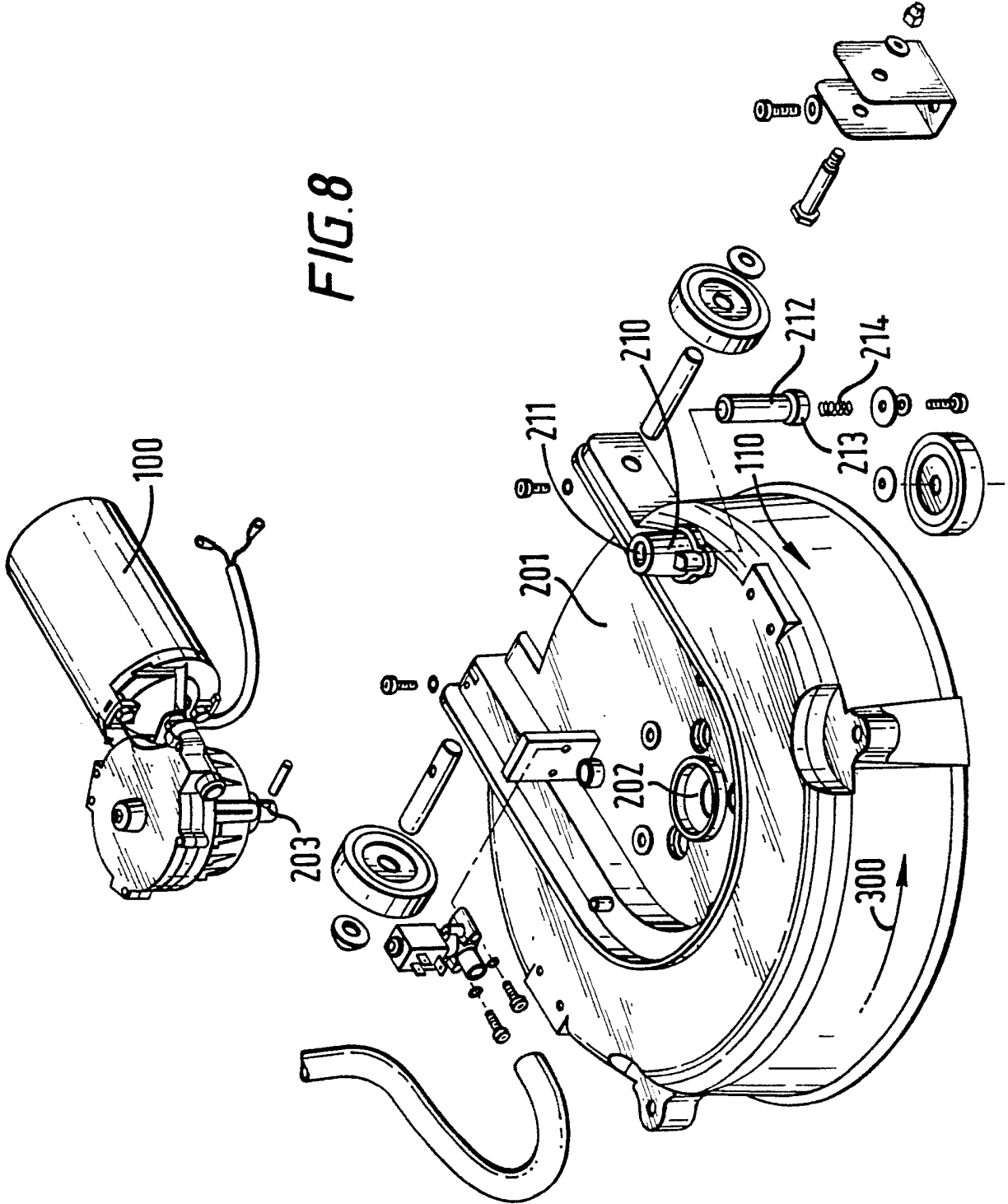

FIG. 8



- 1 -

IMPROVEMENTS IN AND RELATING TO MACHINES FOR
CLEANING FLOOR SURFACES

5

The present invention relates to improvements in and relating to machines for cleaning floor surfaces.

10

The applicants' co-pending international patent application no. PCT/GB93/00118, which is incorporated herein by reference, discloses a machine for floor cleaning which includes means for collecting liquid such, for example, as aqueous detergent or liquid polish from a floor surface. This machine comprises

15 a receptacle for receiving the liquid collected from the floor surface, a vacuum chamber communicating with the receptacle and means for lowering the pressure in the vacuum chamber and receptacle; a conduit is provided which is connected at one end to

20 the chamber; the other end of the conduit is disposed juxtaposed the floor surface. On lowering the pressure within the chamber and receptacle, any

liquid on the floor surface juxtaposed the other end
of the conduit is caused to enter into the conduit
and travel therealong to enter into the vacuum
chamber; the liquid then falls under gravity into the
5 receptacle where it is contained for subsequent
disposal.

In accordance with PCT/GB93/00118 the machine
typically also includes a reservoir for containing
10 liquid to be applied to the floor surface. The
specific embodiment described in PCT/GB93/00118
comprehends such a machine wherein the reservoir,
receptacle and vacuum chamber are stacked with the
reservoir at the bottom, the receptacle in the middle
15 and the vacuum chamber at the top; in use liquid is
continuously dispensed from the reservoir to the
floor surface where it is employed in cleaning the
surface; contemporaneously the liquid is collected
from the floor surface under reduced pressure via the
20 conduit and vacuum chamber assembly and is received
in the receptacle. When all the liquid initially
contained in the reservoir has been applied to the
floor surface, the reservoir must be replenished with
fresh liquid before floor cleaning can be continued.

Similarly, when the receptacle is full of liquid collected from the floor surface, the receptacle must be emptied before any more liquid can be collected. PCT/GB93/00118 specifies that the receptacle may have
5 a capacity of the order of tens of litres; thus removal of the receptacle, when full, may be quite hard work. For this reason, one aspect of the invention forming the subject of PCT/GB93/00118 provides that two smaller receptacles may be
10 provided, each communicating with the vacuum chamber so that the liquid collected from the floor surface is received in two substantially equal portions which can be removed separately from the machine for subsequent disposal.

15

The applicants have now appreciated however that in some instances it may be desirable to re-use the liquid collected in the receptacle(s). For example, where an aqueous solution of detergent is used in
20 cleaning a floor surface which is only lightly soiled, the solution collected from the floor surface after one application may be only slightly dirty and thus perfectly acceptable for at least one further application to the floor. In such case, not only does

re-use of the liquid delay the requirement for disposal of the same and replenishment of the reservoir with fresh liquid, but also such re-use is desirable on environmental grounds because it reduces the total volume of liquid used and subsequently released, after use, into the environment.

According to one aspect of the present invention, therefore, there is provided apparatus for floor cleaning, which apparatus is adapted for translational movement on a floor surface and comprises:

means for applying liquid to a floor surface as the apparatus moves thereon;

first reservoir means adapted to contain liquid for delivery to said floor surface;

liquid collecting means for collecting liquid from said floor surface;

second reservoir means for containing the liquid
so collected; and

communicating means, including selectively
5 operable valve means, between said first and
second reservoir means;

the arrangement being such that on opening said valve
means, liquid is permitted to flow from said second
10 reservoir means to said first reservoir means under
the influence of gravity.

Typically, said second reservoir means may be
disposed above said first reservoir means such that
15 on opening said valve means, liquid in the second
reservoir means is permitted to fall under gravity
into the first reservoir means.

The present invention therefore provides that liquid
20 collected from a floor surface can, at the option of
the user, be re-applied to the floor surface by
emptying some or all of the collected liquid into the
first reservoir means for subsequent delivery to the
floor surface. Thus, where the floor surface is only

lightly soiled, the liquid used for cleaning the floor surface can be re-applied one or more times by recycling the liquid between the first reservoir means and the second reservoir means. Eventually, after a number of successive applications, the liquid will be too dirty for any further re-use, and at this stage, the collected liquid may be thrown away, and the first reservoir means replenished with fresh liquid for continued use of the apparatus.

5

In accordance with the present invention, it will be appreciated that the term "liquid" comprehends any liquid material which is suitable for use in cleaning or polishing a floor surface; "liquid" should therefore be taken to include water, aqueous solutions of detergent or disinfectant and liquid polish.

10

Typically the means for applying liquid to the floor surface may include means for cleaning the floor surface such, for example, as scrubbing means. Said scrubbing means may comprise a work-head comprising one or more brushes or pads, typically circular

20

brushes or pads, adapted for brushing or "buffing"
the floor surface.

Where the workhead comprises a single circular brush,
5 bias means may be provided between the workhead and
carriage means permitting translational movement over
a floor surface, said bias means serving to impart a
loading to said brush means to prevent significant
deviation of the apparatus from the fore-aft line of
10 the machine during translational movement on a floor
surface.

Said bias means may comprise a plunger spring loaded
against said workhead which plunger bears against a
15 chassis part of the apparatus. The spring may be a
compression spring and the bias imparted may be
varied by replacing the spring means with a spring of
a different loading or tension.

20 Said liquid collecting means may comprise means for
collecting said liquid from the floor surface under
reduced pressure; said liquid collecting means may
comprise a vacuum chamber communicating with said
second reservoir means, means for lowering the

pressure in said vacuum chamber, and a conduit
connected at one end to the vacuum chamber, the other
end of the conduit being disposed, in use, in
juxtaposition the floor surface, the arrangement
5 being such that on lowering the pressure in the
vacuum chamber any liquid on the floor surface
juxtaposed said other end of the conduit is caused to
enter into the conduit and travel therealong to the
vacuum chamber where it falls under gravity into the
10 second reservoir means. Said means for lowering the
pressure in said vacuum chamber may comprise a
suction pump having an inlet communicating with said
vacuum chamber. Said inlet may be connected to the
vacuum chamber via a suction line.

15

Said communicating means may comprise conduit means
between said first and second reservoir means. Said
first reservoir means and/or said second reservoir
means may be shaped to define said conduit means
20 therebetween. In one aspect of the invention, said
communicating means may comprise filter means for
filtering said liquid as it flows from said second
reservoir means to said first reservoir means. The

filter means may be disposed in an aperture formed in the top of said first reservoir means.

5 In a further aspect of the invention, filter means may be provided in the vacuum chamber or the second reservoir to filter the collected liquid as it is received within said second reservoir and prior to collection therein.

10 Said valve means may comprise a valve seat, juxtaposed an aperture formed in the bottom of said second reservoir means, and a valve body movable between a first closed position in which said valve body obturates said aperture and a second open
15 position in which liquid is permitted to flow through said aperture. Said valve seat may be formed on an outer surface of the second reservoir means. In such case, it will be appreciated that where said liquid collecting means comprises means for collecting said
20 liquid under reduced pressure, the reduced pressure in the second reservoir means may act at least to assist in retaining said valve body in its first closed position.

Typically, said valve body may be biased in said first closed position; the valve body may be carried by or formed on a push-rod. Said push rod may be sprung-loaded so as to bias the valve body in the first closed position. The push-rod may carry a spring which acts between the push-rod and the second reservoir means; said spring may be a helical spring.

In some embodiments, mechanical advantage means may be provided, said mechanical advantage means being arranged to act between the push-rod and the second reservoir means such that operation of said mechanical advantage means causes or allows said push-rod to move against the influence of said spring-loading so as to cause the valve body to move from said first closed position to said second open position. Said mechanical advantage means may comprise cam means arranged such that rotation of said push-rod causes said push-rod to move longitudinally against the spring-loading. Said cam means may comprise a cam surface formed on or carried by one of said push-rod and said second reservoir means and a cooperating part formed on the other,

said spring-loading may act to urge the cam surface and the cooperating part into mutual engagement.

5 Said cam surface may be defined by a part of said second reservoir means, and said cooperating part may be an abutment on said push-rod, typically a peg.

10 In a further aspect of the present invention, the second reservoir means is adapted to 'nest' with the first reservoir means. The faces of one side of the reservoirs may be contoured to provide an opening through which the lower, first reservoir may be filled with liquid. The opening may be elongate: it may be adapted to receive funnel means to assist
15 filling. The funnel means may be elongate and contoured to be received within said opening, the arrangement being such that the first reservoir means may be filled without removing the second reservoir means therefrom.

20

Following is a description by way of example only and with reference to the accompanying drawings of methods of carrying the present invention into effect:-

IN THE DRAWINGS:

5 Figure 1 is a schematic side view (partly in section) of a machine in accordance with the present invention.

 Figure 2 is a second side view of the machine of Figure 1.

10 Figure 3 is a schematic rear view of the machine of Figure 1.

 Figure 4 is a section on the line IV-IV of Figure 1.

15 Figure 5 is an enlarged sectional side view of part of the machine of Figure 1.

20 Figure 6 is another sectional side view of part of the machine of Figure 1.

Referring to Figure 1, a machine (10) for cleaning a floor surface includes a carriage (12) which

comprises two horizontally spaced, forwardly directed chassis members (18, 19).

5 The carriage (12) is supported towards its rear end (14) on two spaced transit wheels (16), each of which is mounted for rotation on an axle (17) which latter extends transversely of the members (18, 19). Said carriage (12), at its front end (15), carries a workhead assembly (100) which is pivotably mounted
10 between said members (18, 19) about a horizontal axis (117) which is arranged substantially at right angles to the fore-aft direction of the carriage (12).

15 Assembly (100) includes a brush housing (110) which comprises an annulus (112) having a depending cylindrical skirt (114); annulus (112) carries a motor (124), the housing of which is secured to the upper surface of said annulus (112) so that the output shaft of the motor (not shown) extends
20 coaxially downwardly through the central hole of annulus (112). The output shaft is fitted at its lower end with a discoidal pad carrier (also not shown) which is arranged to rotate coaxially within said housing (110). The pad carrier has a generally

circular bottom surface which is provided with means
for releasably fastening thereto a circular brush or
pad unit (122) such that the lower end of said brush
(122) extends downwardly from the housing (110) and,
5 as shown in Figure 1, into working contact with the
surface on which the machine stands.

Motor (124) carries a counterweight (130) (see Figure
2) which is attached to the outer surface of the
10 motor housing and extends rearwardly thereof such
that, in a first position as shown in Figure 1, the
weight of the workhead assembly (100) is disposed
asymmetrically of the pivot axis (117).

15 Brush housing (110) carries two horizontally spaced
wheels or castors (132) which are fastened to a rearwardly
facing part of the external surface of the housing
(110) such that said wheels or castors are disposed on the same
side of the pivot axis (117) as the said
20 counterweight (130).

With reference to Figure 4, annulus (112) is also
provided with two mounting brackets (116) for
mounting the workhead assembly (100) to the said

members (18, 19). Each bracket (116) includes two horizontally spaced upstanding plates (118, 119); each plate having a hole (121) formed therein towards its upper end. The said brackets (116) are
5 positioned diametrically opposite one another on the periphery of said annulus (112) and each is attached to a respective one of the said members (18, 19). A portion of each member (18, 19) passes between the plates (118, 119) of its associated bracket (116),
10 and a pivot pin (120) extends through the said holes (121) of the bracket (116) and through a hole formed in the members (118, 119), thereby to allow pivotal movement of the workhead assembly (100) about the pivot axis (117).

15

In Figure 2, the workhead assembly (110) is shown in a second position in which the workhead assembly (110) is pivotted rearwardly through an angle of about 90° from the first position such that the
20 brush housing (110) is disposed forwardly of front end (15) of carriage (12), and the motor housing (124) is disposed between the said members (18, 19). The workhead assembly (110) is supported on the said wheels or castors (132) which rest on the floor surface

forwardly of the pivot axis (117), such that the weight of the machine and the reaction at the wheels or castors each act about the pivot to retain the workhead assembly in the second or rest position.

5

Carriage (12) has a handle (25) attached at the rear end (15) of the former, which handle (25) includes an upwardly and rearwardly extending elongate shaft (27) which has an handle-bar (29) fastened to its

10

upper-end. The shaft (27) can be fixed relative to the carriage (12) so that an operator of the machine can use the handle to rock the carriage (12)

backwards on its rear wheels (16) with respect to the floor surface, thereby to raise the front end (15) of

15

the carriage, and to lift the workhead assembly (100) away therefrom. As the machine is so rocked the torque exerted by the weight of the workhead assembly (110) about the pivot axis (117) causes the assembly (100) to rotate towards its second position. In the

20

second position, the wheels or castors (132) are disposed forwardly of the pivot axis (117) underneath the brush housing (110), and the front end (15) of the machine is supported thereon.

It will be appreciated that when the workhead assembly of the machine as described herein is positioned in its second rest position the pad or brush unit fastened to the pad holder on the motor shaft is exposed to facilitate maintenance and/or removal and replacement thereof. Moreover, the machine is supported in its second position on the rear wheels and casters thereby to permit easy transit of the machine to and away from the floor to be scrubbed or finished.

In particular, it will be appreciated that when the machine as described herein has the workhead assembly in its second rest position, the brush housing extends upwardly and rearwardly from the point of contact between the floor and the said wheels or castors. The upwardly directed reaction exerted on the wheels or castors, therefore, exerts a torque about pivot axis (117) which acts to retain the workhead assembly in its rest position as the machine is moved over the floor.

However, the pivot between the workhead assembly and the carriage means may be modified in any manner known to a person skilled in the art to provide a locking or detent means whereby the said assembly is
5 releasably secured in the second rest position.

In a particular embodiment of the present invention the workhead assembly (110) comprises a brush housing (201), having a central opening (202) adapted to
10 accomodate the drive spindle (203) of electric motor (100). Spindle (203) is adapted to carry a circular brush (not shown) which in use is adapted to be driven within housing (201), said brush, in service, being in 'brushing' or 'scrubbing' contact with the
15 floor.

The housing is provided on an upper surface and toward a side thereof with an upstanding cylinder (210), said cylinder having at its upper internal edge an
20 inwardly directed annular flange (211). Cylinder (210) accomodates a cylindrical plunger (212) for sliding movement therein. Plunger (212) has a radially projecting annular rib (213), at its lower end, and is biased upwardly by means of spring (214),

acting between the upper surface of housing (201) and the lower end of plunger (212) the upward movement of plunger (212) being limited by the interengagement of rib (213) with flange (211).

5

With the workhead assembly (110) in the operative position as shown in Figure 1, the upper end of plunger (212) bears against a chassis part of the apparatus and imparts a downward bias on the housing (201) and hence on the brush herein so that the contact force between the brush and the floor is greater in juxtaposition the cylinder (210) than over the rest of the brush contact area with the floor.

10

When the brush is rotating the friction between the brush and the floor surface is greatest in the area juxtaposed cylinder (210). Thus if the brush is rotating in the direction shown at (300), the resultant component of friction will impart a forward drive to the apparatus, thus assisting forward motion of the machine while substantially preventing occasional transverse fictional contact between brush and floor.

15

20

The floor maintenance machine (10) in accordance with the invention comprises fluid handling apparatus for supplying a cleaning solution or polish to the floor to be treated with the pad or brush unit (122).

5

Said fluid handling apparatus includes a first receptacle (40) which is mounted on said carriage (12) generally over said rear wheels (16). Said first receptacle includes a generally rectangular bottom wall (42) which is shaped towards one side of the machine to define an upwardly directed recess (44) (see Figure 3).

15

Bottom wall (42) is integrally moulded with two upstanding side walls (43), a generally rectangular rear wall (46), a front wall (45) and a top wall (49); said front wall (45) is shaped in its lower half to define a rearwardly directed recess (48) (see Figure 4) which partially accommodates the motor (124) of the workhead assembly (100) when the latter is in its first working position. Said recess (48) has a rear wall (45A) of arcuate cross-section which is shaped to allow unhindered rotation of the workhead assembly (100) about its pivot axis (117).

20

Said top wall (49) is substantially planar and has a generally rectangular aperture (53) formed therein at a point intermediate said front wall (45) and said rear wall (46); said aperture (53) extends
5 longitudinally between said side walls (43) across the fore-aft direction of the machine. Said top wall (49) extends downwardly from the edge of said aperture (53) to form a depending, peripheral sleeve (54) around the aperture, which sleeve (54)
10 terminates in the interior of the first receptacle in a bottom edge (55).

Intermediate said aperture (53) and said rear wall (46), the top wall (49) is configured to define two
15 parallel spaced elongate channels (50) each channel is U-shaped in cross-section; extends longitudinally in the fore-aft direction of the machine to communicate at a front end (51) with said aperture (53) intermediate the bottom edge (55) of the sleeve
20 (54) and terminates at a rear end (52) just forwards of said rear wall (46); each channel (50) shelves gently downwardly from said rear end (52) as far as the front end (51).

Just below the front end (51) of each of said channels (50), said sleeve (54) carries a filter element (51) which extends across the aperture (53) and is disposed contiguous the inner surface (57) thereof.

5
First receptacle (40) also comprises an outlet (52) which is formed in said bottom wall (42) at its lowest point. Said outlet (52) is connected to one end of a conduit (not shown) which is disposed underneath the first reservoir and terminates at its other end inside brush housing (110) adjacent the pad carrier.

10
15 Said fluid handling apparatus of machine (10) also comprises two second liquid-collecting receptacles (60) which are similar one to the other and are supported side-by-side on the top of said first receptacle (40). Each second receptacle (60) includes a front wall (61), a rear wall (62), two side walls (63), a top wall (70) and a substantially planar bottom wall (64) which rests contiguous the top wall (49) of the first receptacle (40); said bottom wall is shaped to define a downwardly

extending, rectilinear recess (65) of generally rectangular cross-section, which recess (65) extends longitudinally between the side walls (63) of the second receptacle, across the fore-aft direction thereof, and downwardly into the aperture (53) to a point intermediate the bottom of said channels (50) such that said bottom wall (64) forms a tight fit with the inner surface (57) of said sleeve (54).

Intermediate said recess (65) and said rear wall (62), said bottom wall (64) has a circular aperture (66) formed therein, which aperture (66) communicates with a respective one of said channels (50). The outer surface of the bottom wall (64), see Figure 5, is raised slightly circumjacent said aperture (66) to form an annular valve seat (57); aperture (66) accommodates a spider (68) which has a central hole (69) formed therein.

Top wall (70) is substantially planar and has a generally rectangular opening (71) formed therein towards said front wall (61); juxtaposed said opening (71) the top wall (70) is raised slightly to form a peripheral flat-topped rim (72) around the opening,

and the top wall (70) extends downwardly from the edge of the opening into the interior of the second receptacle to form a short depending sleeve (73).

5 Intermediate said opening (71) and said rear wall (62), the top wall (70) has a circular opening (74) formed therein (see Fig. 5); said circular opening (74) is disposed coaxially with the circular aperture (66) formed in said bottom wall and accommodates one
10 end (76) of an elongate push-rod (75), the other end (77) of the push-rod (75) extends through the central hole (69) of said spider (68) and carries a discoidal valve body (78) disposed in said respective channel (50). Said valve body (78) has a circular upper
15 surface (78A) which is provided with a circular compressible wad (79) thereon.

Said one end (76) of the push-rod carries a knob (76A) and a helical spring (76B) which acts between
20 the knob (76A) and the upper surface of said top wall (70); said helical spring urges the push-rod in an upwards longitudinal direction so that said valve body (78) is urged against the valve seat (67) to

compress said compressible wad (79) therebetween to form a substantially liquid-tight seal.

5 The inner surface of said top wall (70) is configured circumjacent the circular opening (74) to define a planar surface which is skewed with respect to the longitudinal direction of the elongate push-rod to provide a cam surface (78C); said push-rod (75) is provided with a radially extending peg (78D) which
10 abuts on said cam surface. When the valve body is disposed on the valve seat so as to obturate said aperture (66) as shown in Figure 5, the peg (76D) is positioned at the upper extent of the cam surface; rotation of the push-rod (75) through 180° by
15 manipulation of the knob (76A) causes said peg (76D) to slide progressively over the cam surface (76C) towards the lower extent of the same as shown in Figure 6 , thereby causing the push-rod to move longitudinally downwardly against the action of said
20 helical spring (76B) to remove the valve body (78) from said valve seat (67) so that the interior of the second receptacle (60) communicates with said respective channel (51) via said circular aperture (66).

Said second receptacles (60) together support a vacuum chamber (80) comprising a bottom wall (82), a front wall (87), a rear wall (88), a top wall (89) and side walls (86); said bottom wall (82) has two spaced apertures (81) formed therein, each aperture (81) being positioned juxtaposed the rectangular opening (71) formed in a respective one of said second receptacles (60) for communication therewith. Said bottom wall extends outwardly of said front, rear and side walls to provide a peripheral flange (83) having a substantially planar bottom surface (83A); the flange (83) is turned downwardly at its extremity to define a peripheral shoulder portion (84). The vacuum chamber (80) is supported on the second receptacles (60) such that the shoulder portion (84) is seated contiguous the peripheral rim (72) formed around each opening (71); a wad of compressible material (not shown) is interposed between the bottom wall (82) of the vacuum chamber (80) and the flat upper surface of each peripheral rim (72) so as to form a substantially air-tight seal between the second receptacle (60) and the vacuum chamber (80) around each of said rectangular openings (71).

Said rear wall (88) has an aperture (90) formed therein, which aperture (90) has a boss (91) fastened thereon. Boss (91) is connected to two flexible vacuum conduits (92) and (93) (not shown).

5

One of the said conduits (92), which is shown in Figure 1, extends downwardly from said boss (91) and carries at its lower end an elongate nozzle assembly (94) which is oriented transversely of the carriage (12). Said nozzle (94) comprises a depending peripheral skirt (95) which is formed of a plurality of flexible bristles. The nozzle assembly (94) is secured in vertical spaced relationship with the floor by a retainer bar (96) which is fastened at one end to the nozzle (94) and at its other end to the rear end (14) of carriage (12), the arrangement being such that the lower ends of the bristles (95) are drawn across the floor as the machine (10) is moved thereover.

10

15

20

Said other conduit (93) is connected at its other end to an electrically operated suction pump (97) (see Figure 3) which is mounted on the carriage (12) above

the rear wheels (16) in the recess (44) formed in the bottom of the first receptacle (40).

5 In use, the push-rod (75) on each second receptacle (60) is initially oriented such that said peg (76D) abuts on the cam surface (76C) at the upper extent of the latter (Figure 5) whereby said valve body (78) obturates said circular aperture (66). The first
10 receptacle (40) is filled with liquid polish or aqueous detergent solution, and the machine (10) is moved over the floor with the workhead assembly (100) in its first working position such that the brush or pad is held in working contact with the floor surface. The liquid is dispensed at a predetermined
15 rate from said first receptacle (40) to the floor through its outlet conduit, and the pad or brush unit (122) is driven by the said motor (124) to rotate on the floor thereby to effect polishing or scrubbing thereof.

20

Suction pump (97) effects a reduced pressure in said chamber (80) and each of said second receptacles (60), which reduction in pressure causes air, liquid and dirt and other dust and detritus at the floor to

enter into said conduit (92) at nozzle assembly (94).
The liquid slurry is sucked into the nozzle (94) and
travels up conduit (92) until it reaches boss (91).
The liquid portion and any relatively massive
5 particulate matter then falls under gravity through
the chamber (80) and said rectangular openings (71)
into the said second liquid collecting receptacles
(60). The air and any relatively less massive
detritus entrained therein passes along conduit (95)
10 to the suction pump (97) where it is expelled into
the surroundings. The pressure reduction in the said
chamber (80) and second receptacles (60) as compared
with atmospheric pressure has the advantageous
ancillary effect of effecting a mutual attractive
15 force therebetween, which force urges the bottom wall
(82) of the former against the top walls (70) of the
latter to compress the wad between the rim and the
vacuum chamber (80) to reinforce the air-tight seal
therebetween.

20

When the liquid collecting second receptacles (60)
are full or nearly full, the suction pump (97) is
switched off thereby releasing the attractive force

between the chamber (80) and the said second receptacles (60).

Vacuum chamber (60) can then be removed, and the
5 second receptacles (60) removed separately from the
first receptacle (40) for emptying and replenishment
of the latter; alternatively, if the user of the
machine decides that the liquid collected in the
second receptacles is not too dirty to be re-used,
10 the push-rod (75) associated with each second
receptacle (60) may be rotated by manipulation of the
knob (76A). The peg (76D) is thereby caused to slide
over the cam surface (76C) towards the lower extent
of the latter (Figure 6) thus causing said push-rod
15 (75) to move longitudinally downwards against the
action of helical spring (76B), thereby removing the
valve body (78) from said valve seat (67); liquid in
each second receptacle is thus permitted to flow into
a respective one of said channels (50) into said
20 first receptacle (40) via said filter element (56) in
said aperture (53).

When some or all the liquid (at the option of the user) in the second receptacles (60) has drained into the first receptacle (40), the valve body (78) associated with each second receptacle is returned to its closed position (Figure 5) in which it obturates said aperture (66) by rotation of the push-rod (75); the machine is then ready for continued use.

It will be appreciated that, in a variant of the present invention as described herein, a single liquid collecting second receptacle (60) may be substituted for the two separately mounted second receptacles (60), although the latter arrangement described above, by way of example, facilitates the emptying operation since each receptacle will contain only about half the total weight of collected liquid.

In an alternative embodiment as shown in Figure 7, the second receptacles (60) are replaced by a single second receptacle (260). In this embodiment a single liquid release (270) may be provided. The upper part of the receptacle (260) may be provided with a filter (275) adapted to remove particulate debris as liquid enters the receptacle (260). The liquid release

means (270) is generally as described with reference to Figure 5. The valve element (271) is generally frustoconical to provide improved seating against valve seat (272).

5

The forward lower part (273) of receptacle (260) is inclined upwardly to define a laterally elongate opening (274). Opening (274) accommodates a hopper (276; as shown in Figure 7, for filling the lower first receptacle (40) without removing the upper
10 second receptacle (260).

CLAIMS

1. Apparatus for floor cleaning which apparatus comprises means enabling translational movement over a floor surface, means for applying liquid to a floor surface as
5 the apparatus moves thereon, first reservoir means adapted to contain liquid for delivery to said floor surface, liquid collecting means for collecting liquid from said floor surface, second reservoir means for
10 containing the liquid so collected and communicating means including selectively operable valve means between said first and second reservoir means, the arrangement being such that on operating said valve means liquid is permitted to flow from said second reservoir means to
15 said first reservoir means under the influence of gravity.

2. Apparatus as claimed in Claim 1 wherein the second reservoir means is disposed above said first reservoir
20 means such that liquid in the second reservoir means is permitted to fall under gravity into the first reservoir means.

3. Apparatus as claimed in either of the preceding claims
25 wherein the means for applying the liquid to the floor includes means for cleaning the floor surface.

4. Apparatus as claimed in Claim 3 wherein the means for cleaning the floor surface comprises a rotating workhead consisting of one or more brushes or pads.
- 5 5. Apparatus as claimed in any one of the preceding claims wherein the liquid collecting means comprises means for collecting liquid from the floor surface under reduced pressure, said liquid collecting means comprising a vacuum chamber communicating with said second reservoir means, means for lowering the pressure in said vacuum chamber and a conduit connected at one end to the vacuum chamber the other end of the conduit being disposed in use in juxtaposition of the floor surface, the arrangement being such that on lowering the pressure in the vacuum chamber any liquid on the floor surface juxtaposed the other end of the conduit is caused to enter the conduit and travel therealong to the vacuum chamber where it falls under gravity into said second reservoir means.
- 10
- 15
- 20
- 25 6. Apparatus as claimed in Claim 5 wherein said means for lowering the pressure in said vacuum chamber comprises a suction pump having an inlet communicating with the vacuum chamber.

7. Apparatus as claimed in Claim 6 wherein said inlet may be connected to the vacuum line via a suction line.
- 5 8. Apparatus as claimed in any one of Claims 5 to 7 wherein said communicating means comprises conduit means between said first and second reservoir means.
- 10 9. Apparatus as claimed in any preceding claim wherein said first reservoir means and said second reservoir means is shaped to define said conduit means there between.
- 15 10. Apparatus as claimed in any preceding claim wherein the communicating means includes filter means for filtering said liquid as it flows from said second reservoir means to said first reservoir means.
- 20 11. Apparatus as claimed in Claim 10 wherein the filter means is disposed in an aperture formed in the top of said first reservoir means.
- 25 12. Apparatus as claimed in any preceding claim wherein a filter is provided for the second reservoir means thereby to filter collected liquid as it is received within said second reservoir means and

prior to collection therein.

13. Apparatus as claimed in any preceding claim wherein
said valve means comprises a valve seat juxtaposed
5 an aperture formed in the bottom of said second
reservoir means and a valve body moveable between
a closed position in which said valve obturates
said aperture and an open position in which liquid
is permitted to flow through said aperture.
- 10
14. Apparatus as claimed in Claim 13 wherein said valve
seat may be formed on the outer surface of the
second reservoir means.
- 15
15. Apparatus as claimed in any one of Claims 12 to 14
wherein the valve body is substantially
frustoconical and is arranged to be biased to a
closed position whereby the vacuum applied to the
second reservoir means assists the maintenance of
20 said valve member in the closed position.
16. Apparatus as claimed in any one of Claims 12 to 15
wherein the valve body is actuated by means of a
push rod which is spring loaded to bias the body to
25 the closed position.
17. Apparatus as claimed in Claim 16 wherein the spring

loading of the push rod acts between the push rod and the second reservoir means; said spring loading comprising a helical compression spring.

5 18. Apparatus as claimed in any preceding claim wherein the second reservoir means is adapted to nest with the upper part of the first reservoir means and the faces of one side of each of the reservoirs is contoured to provide an opening through which the
10 lower first reservoir means may be filled.

19. Apparatus as claimed in Claim 18 wherein the opening adapted to receive funnel means to assist said filling, the arrangement being such that the
15 first reservoir means may be filled without removing the second reservoir means therefrom.

20. Apparatus as claimed in any preceding claim wherein the workhead comprises a singular circular brush
20 adapted for rotation about an axis.

21. Apparatus as claimed in Claim 20 wherein bias means is provided between the workhead and the carriage means, said bias means serving to impart a loading
25 to said brush means to prevent significant deviation of the apparatus from a fore aft line of the machine during translational movement on the

floor surface.

22. Apparatus as claimed in Claim 21 wherein said bias means comprises a plunger spring loaded against said workhead, which plunger bears against the chassis part of said carriage.
23. Apparatus as claimed in Claim 22 wherein the spring means may be a compression spring and the bias imparted may be varied by replacing the spring means with a spring of a different loading or tension.
24. Apparatus as claimed in Claim 1 and substantially as herein described with reference to and as illustrated in Figures 1 to 8 of the accompanying drawings.

Patents Act 1977
 Examiner's report to the Comptroller under Section 17
 (The Search report)

39

Application number
 GB 9402326.4

Relevant Technical Fields

- (i) UK Cl (Ed.M) A4F
- (ii) Int Cl (Ed.5) A47L 7/00, 11/20, 11/29, 11/30

Search Examiner
 A C HOWARD

Date of completion of Search
 16 MARCH 1994

Databases (see below)

(i) UK Patent Office collections of GB, EP, WO and US patent specifications.

Documents considered relevant following a search in respect of Claims :-
 1-23

(ii) ONLINE DATABASE: WPI

Categories of documents

- X:** Document indicating lack of novelty or of inventive step. **P:** Document published on or after the declared priority date but before the filing date of the present application.
- Y:** Document indicating lack of inventive step if combined with one or more other documents of the same category. **E:** Patent document published on or after, but with priority date earlier than, the filing date of the present application.
- A:** Document indicating technological background and/or state of the art. **&:** Member of the same patent family; corresponding document.

Category	Identity of document and relevant passages	Relevant to claim(s)
A	EP 0185310 (TENNANT) Whole document	
A	US 4466155 (GRAVE) Whole document	
X	US 3996640 (BLUE ET AL) See column 2 line 36 - column 3 line 3 and column 4 line 63	1-8, 10

Databases: The UK Patent Office database comprises classified collections of GB, EP, WO and US patent specifications as outlined periodically in the Official Journal (Patents). The on-line databases considered for search are also listed periodically in the Official Journal (Patents).