

(12) UK Patent Application (19) GB (11) 2 354 271 (13) A

(43) Date of A Publication 21.03.2001

(21) Application No 0022646.4

(22) Date of Filing 14.09.2000

(30) Priority Data

(31) 9921557 (32) 14.09.1999 (33) GB

(71) Applicant(s)

Weatherford/Lamb, Inc.
(Incorporated in USA - Delaware)
1013 Centre Road, Wilmington, Delaware 19805,
United States of America

(72) Inventor(s)

Paul David Metcalfe

(74) Agent and/or Address for Service

Cruikshank & Fairweather
19 Royal Exchange Square, GLASGOW, G1 3AE,
United Kingdom

(51) INT CL⁷
E21B 43/10

(52) UK CL (Edition S)
E1F FAC FAC9 FJF

(56) Documents Cited

EP 0952305 A1 WO 99/23354 A1 WO 98/49423 A1
FR 002326229 A FR 000721430 A

(58) Field of Search

UK CL (Edition R) E1F FAC FJF
INT CL⁷ E21B 43/08 43/10
EPODOC WPI JAPIO

(54) Abstract Title

Expandible tubing with filter media

(57) Expandible tubing (10) (contracted fig 1, expanded fig 2) is formed from a number of deformable tubular structures (14), where some of the tubular structures have permeable walls containing filter media (28, fig 3), thereby allowing fluid to flow through the tubular structures (14), the filter media (28) and thus through the tubing wall. The tubing (10) can be formed from sintered ductile material and prevent particulate flow through the tubing wall. The tubular structures (14) may be configured in a number of ways. The expandible tubing (10) may have porous walls which are initially filled with a non-porous material that can be dissolved to allow fluid flow to take place.

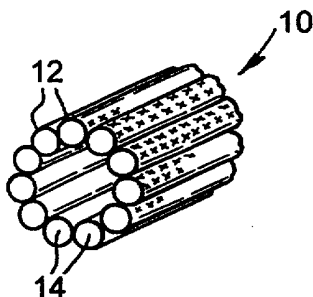

Fig.1

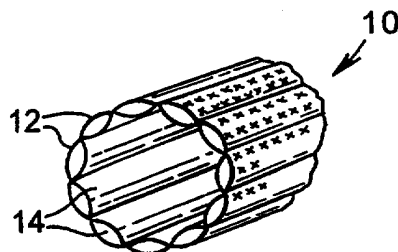

Fig.2

At least one drawing originally filed was informal and the print reproduced here is taken from a later filed formal copy.

This print takes account of replacement documents submitted after the date of filing to enable the application to comply with the formal requirements of the Patents Rules 1995

GB 2 354 271 A

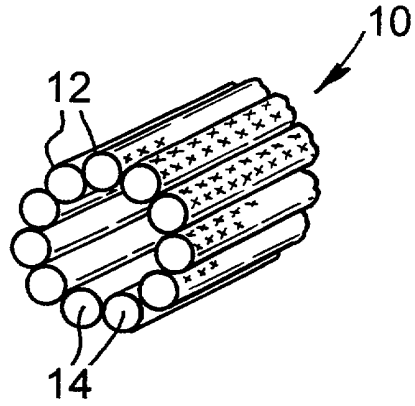

Fig.1

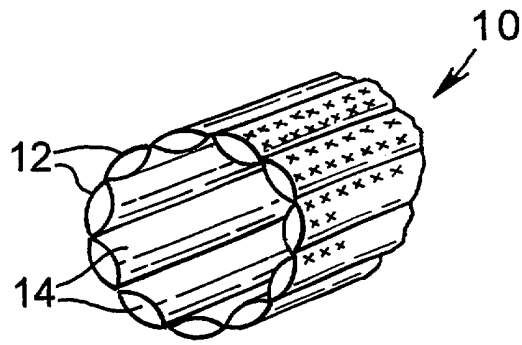

Fig.2

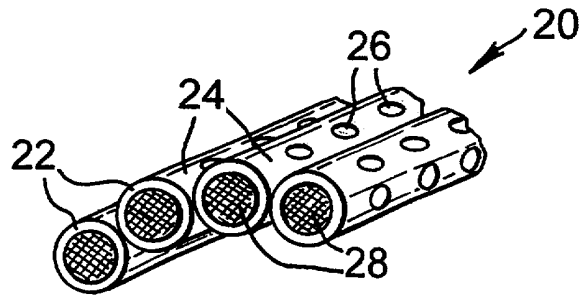

Fig.3

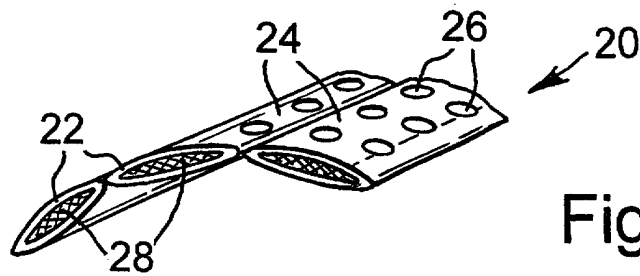

Fig.4

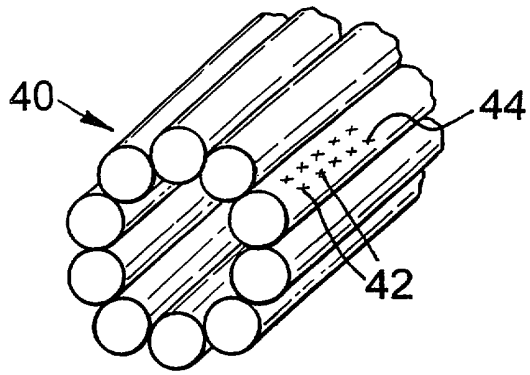

Fig. 5

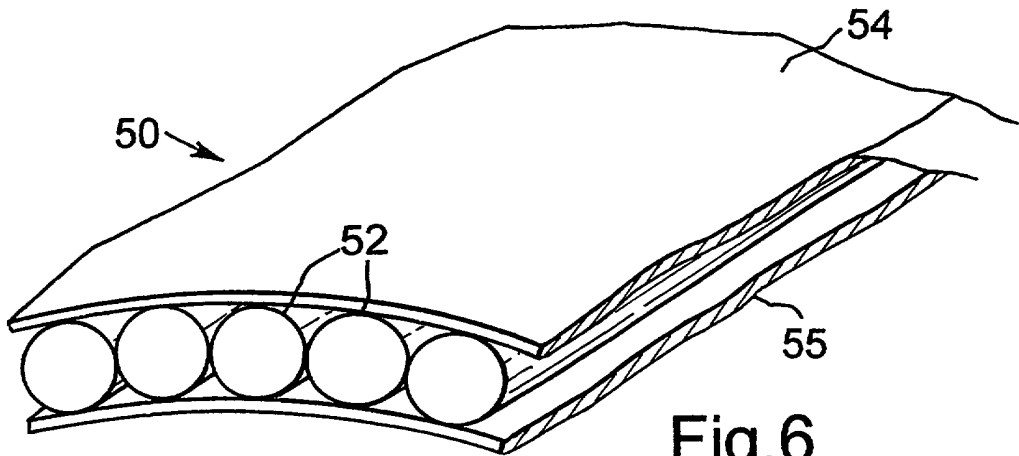

Fig. 6

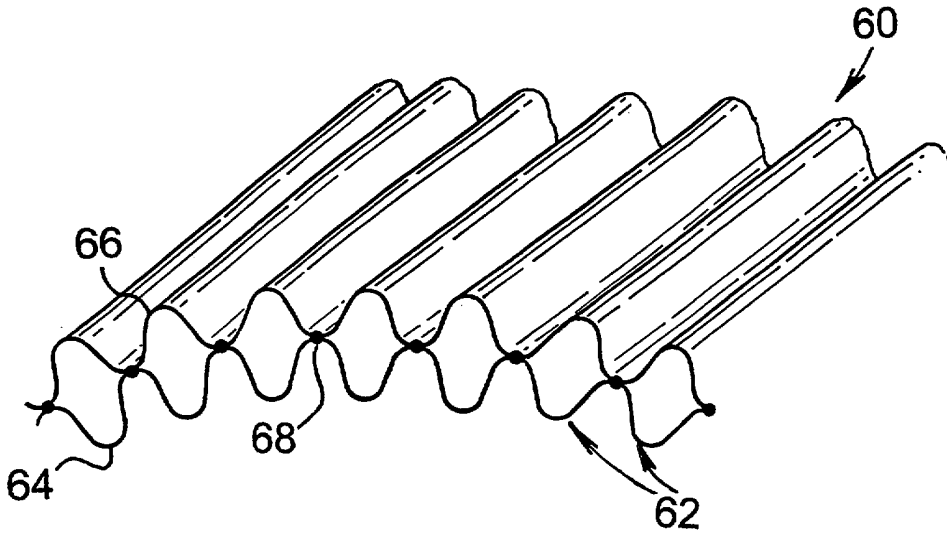

Fig. 7

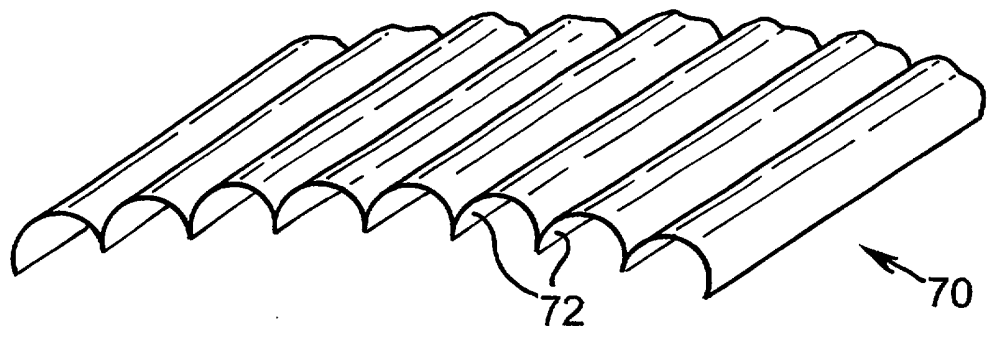

Fig. 8

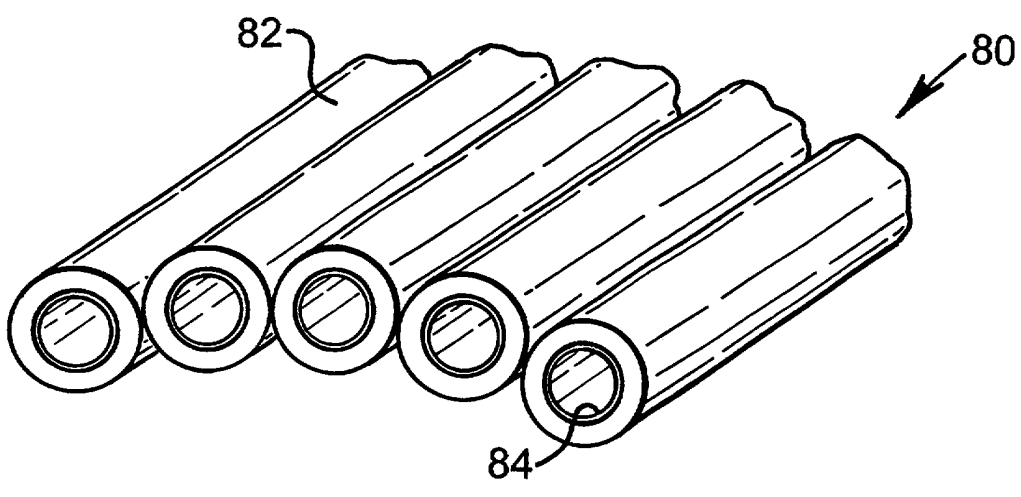

Fig. 9

DOWNHOLE APPARATUS

This invention relates to a downhole apparatus, and in particular but not exclusively to forms of expandable tubing and to forms of expandable filters and filter supports.

5 WO93/25800 (Shell Internationale Research Maatschappij B.V.) describes a method of completing an uncased section of borehole. A slotted liner provided with overlapping longitudinal slots is fixed in the borehole and a tapering expansion mandrel is pushed or pulled through the liner.
10 The liner is expanded by the mandrel to support the adjacent borehole wall.

 WO97/17524 (Shell Internationale Research Maatschappij B.V.) describes a deformable well screen and method for its installation utilising two sections of concentric slotted
15 tubing, such as described in WO 93/25800, with a series of circumferentially scaled filter segments therebetween. The screen is expanded by pushing or pulling an expansion mandrel through the screen.

 The expansion mechanism of these arrangements is such
20 that there is an axial retraction of the tubing on radial expansion. This not only creates difficulties in accurately locating and securing the ends of the tubing in a bore relative to adjacent tubing sections, but also may

result in undesirable relative axial movement between the tubing and other elements mounted thereon, such as filter segments. Further, in such a filter arrangement, the radial expansion forces which must be applied to the outer section of expandable tubing are transferred via the filter medium or media located between the tubing sections; this limits the range of media which may be utilised in such arrangements to filter materials and configurations which will withstand significant compressive forces, in addition to the significant shear forces which the filter material will experience during expansion of the tubing sections.

It is among the objectives of embodiments of aspects of the invention to provide alternative expandable tubing forms, including expandable filters and filter supports, which overcome such disadvantages.

According to the present invention there is provided expandable tubing having a tubing wall comprising a plurality of deformable tubular structures, at least some of the structures having permeable walls and containing a filter medium such that fluid may flow through the structures and thus through the tubing wall.

This aspect of the invention is useful as a downhole filter or sand screen, the deformable tubular structures forming the wall of the tubing facilitating expansion of the tubing, and the tubular structures potentially serving as filter elements and also accommodating a selected filter

medium or media. Also, the use of the tubular structures to accommodate or facilitate expansion assists in avoiding the longitudinal contraction which tends to occur on radial expansion of tubing defining overlapping longitudinally extending slots.

The tubular structures may extend longitudinally, helically, or in be positioned in any appropriate orientation. A substantially axial orientation may offer more straightforward assembly and resistance to bending, however for other applications a helical arrangement may offer greater flexibility and resistance to radial compressive forces.

The tubular structures may be of any material, structure or form which provides the desired degree of deformability, permeability and the desired degree of structural strength. In one embodiment, the tubular structures are of sintered ductile metal, while in other embodiments drilled or slotted tubes may be utilised. If sintered metal, or some other porous material of similar structure, is utilised to form the tubular structures, the pores of the material may be initially filled or occupied by another material to create an impermeable structure. This filling material may be subsequently removed, for example by application of an appropriate solvent, which may be produced fluid, or exposure to elevated temperature as experienced in deeper bores.

The tubular structures may be connected to one another by any appropriate method, for example metal structures may be welded or brazed to one another, or the structures may be retained between two expandable sleeves or tubes.

5 In other embodiments, the tubular structures may be defined by appropriately shaped sheets or elements, or unitary structures, for example two corrugated sheets or tubes which have been welded or otherwise secured together, or by extruding or otherwise forming the tubing wall in a
10 form which incorporates tubular structures. These embodiments may form other aspects of the invention, in which the tubular structures are impermeable, that is fluid is prevented from flowing through the tubing wall, in one or both of the unexpanded and expanded configurations.

15 The tubular structures may feature substantially continuous walls, or may have discontinuities therein, for example the tubular structures may be substantially C-shaped.

The tubular structures may accommodate a filter medium
20 of media, such as woven wire, porous foam, wire mesh or wire wool, or indeed any medium presently utilised as a filter and which could be located within a tubular structure and withstand the change in shape experienced by the tubular structures during expansion. Alternatively or
25 in addition, the tubular structures may be lined with a filter media in the form of a flexible or deformable porous

material.

The aperture or pore size defined by the tubular structures or the filter media therein may be selected as appropriate, depending on the intended application of the tubing: the tubing may provide a relatively coarse filter, for preventing passage of relatively large solids, or may be such that passage of liquid or very fine solids is prevented or restricted, and only passage of gas is permitted, by use of a tubular structure-lining material such an expanded PTFE, as produced under the Gore-Tex trade mark by W.L. Gore & Associates.

These and other aspects of the present invention will now be described, by way of example, with reference to the accompanying drawings, in which:

Figure 1 is a diagrammatic representation of an expandable tubing in accordance with an aspect of the present invention;

Figure 2 shows the tubing of Figure 1 following expansion;

Figure 3 is a diagrammatic representation of part of a wall of an expandable tubing in accordance with a further aspect of the present invention;

Figure 4 shows the tubing of Figure 3 following expansion;

Figure 5 illustrates an expandable tubing in accordance with a still further aspect of the present

invention; and

Figures 6 to 9 are diagrammatic representations of walls of expandable tubings in accordance with further aspects of the present invention.

5 Reference is first made to Figures 1 and 2 of the drawings, which illustrate a form of expandable tubing 10, in accordance with an aspect of the present invention, and which may be utilised as or as part of a sand screen or other downhole filter arrangement. Typically, the tubing
10 will be run into a bore in the "unexpanded" form as illustrated in Figure 1, anchored in the bore, and then expanded to the larger diameter expanded form as illustrated in Figure 2, with a degree of expansion in excess of 30% being achievable.

15 The tubing wall 12 comprises a plurality of axially extending tubular structures in the form of small diameter tubes 14 formed of sintered metal. The tubes 14 provide a porous sand filtering media.

Expansion of the tubing 10 is primarily accommodated
20 by a flattening of the tubes 14, and the expanded tubing is shown in Figure 2 of the drawings. This expansion may be achieved by means of a conventional expanding cone or mandrel, which is pushed or pulled through the tubing 10. As the tubes 14 deform there will also be some deformation
25 and variation in the sizes of the pores, apertures and passages in the walls of the tubes, however pore size

variation may be predicted to some extent, and in any event it is difficult to form a porous sintered metal product with closely controlled pore size.

Reference is now made to Figures 3 and 4 of the drawings, which illustrate part of an alternative expandable tubing 20, in which the tubing wall 22 comprises a plurality of solid tubes 24 having holes 26 drilled therein. The tubes 24 accommodate filter media 28 which may be in the form of deformable woven wire, porous foam, wire mesh or wire wool. On expansion of the tubing, to the form illustrated in Figure 4, the aperture or pore size of the filter media 28 will not tend to change (although the filter media may be subject to some compaction), providing a greater degree of predictability than the tubing 10 described above.

Reference is now made to Figure 5 which illustrates a similar form of expandable tubing 40 to that shown in Figure 1, except that the pores 42 of the material forming the tube walls are initially filled by another removable material 44 thus (temporarily) creating an impermeable structure. This filling material 44 may be subsequently dissolved, or removed by exposure to elevated temperatures.

Figure 6 illustrates a further alternative embodiment of the present invention in which the tubular structures 52 are retained between two expandable sleeves 54, 55

Figure 7 illustrates a wall section 60 of tubing 60 of

a further embodiment of the present invention wherein the tubular structures 62 are defined by inner and outer corrugated sheets 64, 66. These sheets 64, 66 are welded together at 68.

5 Reference is now made to Figure 8, which shows a wall section of tubing 70 of another embodiment of the invention, which tubing features an alternative form of tubular structures 72 to define the bounding walls of the expandable tubing 70. In this particular example, the
10 tubular structures 72 do not have continuous walls, being substantially C-shaped.

 Figure 9 illustrates a wall section of tubing 80 of a further embodiment of the invention. In this embodiment, the porous tubular structures 82 are lined with a filter
15 membrane 84. In this example the membrane 84 is a flexible porous material, in particular expanded PTFE, as sold under the GORE-TEX trade mark, and is impervious to selected liquids, and only permits passage of gas therethrough.

 It will be apparent to those of the skill in the art
20 that the above-described embodiments are merely exemplary of the various aspects of the present invention, and that various modifications and improvements may be made thereto without departing from the scope of the present invention.

CLAIMS

1. Expandable tubing having a tubing wall comprising a plurality of deformable tubular structures, at least some of the structures having permeable walls and containing a filter medium such that fluid may flow through the structures and the filter medium and thus through the tubing wall.
2. The tubing of claim 1, wherein the tubing is adapted to prevent flow of particulates through the tubing wall.
3. The tubing of claim 1 or 2, wherein the tubular structures extend longitudinally of the tubing.
4. The tubing of any of the preceding claims, wherein the tubular structures are of sintered ductile metal.
5. The tubing of any of the preceding claims, wherein the tubular structures are of porous material and the pores of the material are initially filled by another removable material to create an initially impermeable structure.
6. The tubing of any of claims 1, 2 or 3, wherein the tubular structures are apertured tubes.

7. The tubing of any of the preceding claims, wherein the tubular structures are retained between two expandable sleeves.

5 8. The tubing of any of claims 1 to 6, wherein the tubular structures are defined by corrugated members.

9. The tubing of any of the preceding claims, wherein the tubular structures have substantially continuous walls.

10 10. The tubing of any of claim 1 to 8, wherein the tubular structures have discontinuities therein.

11. The tubing of claim 10, wherein the tubular structures are substantially C-shaped.

12. The tubing of any of the preceding claims, wherein the tubular structures are lined with a filter medium.

15 13. The tubing of claim 12, wherein the filter medium lining is a flexible porous material.

14. The tubing of claim 13, wherein the flexible porous material is adapted to prevent passage of selected liquids therethrough but to permit passage of gas therethrough.

15. Expandable tubing having a tubing wall comprising a plurality of deformable tubular structures, at least some of the structures having porous walls of sintered ductile material such that fluid may flow through the structures
5 and through the tubing wall.

16. Expandable tubing having a tubing wall comprising a plurality of deformable tubular structures, at least some of the structures having walls of porous material initially filled by another removable material to create an initially
10 impermeable structure, such that upon removal of said removable material fluid may flow through the structures and thus through the tubing wall.

17. Expandable downhole tubing having a tubing wall comprising a plurality of deformable tubular structures
15 retained between two expandable sleeves.

18. Expandable downhole tubing having a tubing wall comprising a plurality of deformable tubular structures defined by a plurality of corrugated members.

19. The tubing of claim 18, wherein at least some of the
20 structures have permeable walls such that fluid may flow through the structures and thus through the tubing wall.

20. Expandable downhole tubing having a tubing wall comprising a plurality of deformable tubular structures, the tubular structures having discontinuities therein.

5 21. The tubing of claim 20, wherein at least some of the structures have permeable walls such that fluid may flow through the structures and thus through the tubing wall.

22. The tubing of claim 20 or 21, wherein the tubular structures are substantially C-shaped.

10 23. Expandable tubing having a tubing wall comprising a plurality of deformable tubular structures, at least some of the structures having permeable walls lined with a filter medium such that fluid may flow through the structures and the filter medium and thus through the tubing wall.

15 24. The tubing of claim 23, wherein the filter medium lining is a flexible porous material.

25. The tubing of claim 24, wherein the flexible porous material is a membrane adapted to prevent passage of selected liquids and permit passage of gas therethrough.



INVESTOR IN PEOPLE

Application No: GB 0022646.4
Claims searched: 1-16, 23-25

Examiner: Dr. Lyndon Ellis
Date of search: 5 January 2001

Patents Act 1977 Search Report under Section 17

Databases searched:

UK Patent Office collections, including GB, EP, WO & US patent specifications, in:

UK CI (Ed.S): E1F FAC, FJF

Int CI (Ed.7): E21B

Other: Online: EPODOC, WPI, JAPIO

Documents considered to be relevant:

Category	Identity of document and relevant passage	Relevant to claims
A, P	EP 0952305 A1 (Shell) Whole document, noting column 6, lines 22-32	-
A	WO 99/23354 A1 (Petroline)	-
A	WO 98/49423 A1 (Shell)	-
A	FR 2326229 (Grihangne)	-
A	FR 721430 (Kapferer) Fig 3 in particular	-

X	Document indicating lack of novelty or inventive step	A	Document indicating technological background and/or state of the art.
Y	Document indicating lack of inventive step if combined with one or more other documents of same category.	P	Document published on or after the declared priority date but before the filing date of this invention.
&	Member of the same patent family	E	Patent document published on or after, but with priority date earlier than, the filing date of this application.