

(12) INTERNATIONAL APPLICATION PUBLISHED UNDER THE PATENT COOPERATION TREATY (PCT)

(19) World Intellectual Property Organization
International Bureau



(43) International Publication Date
30 August 2001 (30.08.2001)

PCT

(10) International Publication Number
WO 01/62134 A2

- (51) International Patent Classification⁷: **A61B**
- (21) International Application Number: PCT/IL01/00177
- (22) International Filing Date: 25 February 2001 (25.02.2001)
- (25) Filing Language: English
- (26) Publication Language: English
- (30) Priority Data:
09/512,294 24 February 2000 (24.02.2000) US
- (71) Applicant (for all designated States except US): **V-TARGET LTD.** [IL/IL]; 3 Ha'etgar Street, 39120 Tirat Hacarmel (IL).
- (72) Inventors; and
- (75) Inventors/Applicants (for US only): **FRONT, Yaron** [IL/IL]; 11/24 Mendel Zinger Street, 34984 Haifa (IL). **BEN DAVID, Gal** [IL/IL]; 238 Hazait Street, 17940 Mitzpe Adi (IL).
- (74) Agent: **G. E. EHRLICH (1995) LTD.**; 28 Bezalel Street, 52521 Ramat Gan (IL).
- (81) Designated States (national): AE, AG, AL, AM, AT, AU, AZ, BA, BB, BG, BR, BY, BZ, CA, CH, CN, CR, CU, CZ, DE, DK, DM, DZ, EE, ES, FI, GB, GD, GE, GH, GM, HR, HU, ID, IL, IN, IS, JP, KE, KG, KP, KR, KZ, LC, LK, LR, LS, LT, LU, LV, MA, MD, MG, MK, MN, MW, MX, MZ, NO, NZ, PL, PT, RO, RU, SD, SE, SG, SI, SK, SL, TJ, TM, TR, TT, TZ, UA, UG, US, UZ, VN, YU, ZA, ZW.
- (84) Designated States (regional): ARIPO patent (GH, GM, KE, LS, MW, MZ, SD, SL, SZ, TZ, UG, ZW), Eurasian patent (AM, AZ, BY, KG, KZ, MD, RU, TJ, TM), European patent (AT, BE, CH, CY, DE, DK, ES, FI, FR, GB, GR, IE, IT, LU, MC, NL, PT, SE, TR), OAPI patent (BF, BJ, CF, CG, CI, CM, GA, GN, GW, ML, MR, NE, SN, TD, TG).
- Published:**
— without international search report and to be republished upon receipt of that report
- For two-letter codes and other abbreviations, refer to the "Guidance Notes on Codes and Abbreviations" appearing at the beginning of each regular issue of the PCT Gazette.



WO 01/62134 A2

(54) Title: A METHOD AND SYSTEM FOR GUIDING A DIAGNOSTIC OR THERAPEUTIC INSTRUMENT TOWARDS A TARGET REGION INSIDE THE PATIENT'S BODY

(57) Abstract: Method and system are presented for guiding a diagnostic or therapeutic instrument towards a correct target inside the patient's body. A combined image obtained by registering structural and functional images of at least a portion of the patient's body including the target is used together with a guiding device. The guiding device has an indicator associated with the instrument, and is operable for presenting data indicative of a position of a location on the instrument relative to any other point in the at least portion of the patient's body. The guiding device is connectable to a computer device displaying the combined image and operable thereby for guiding the instrument towards the target.

- 1 -

A Method and System for Guiding a Diagnostic or Therapeutic Instrument Towards a Target Region Inside the Patient's Body

FIELD OF THE INVENTION

The present invention is generally in the field of the diagnosis and treatment of ailments such as cancer, and relates to a method and system for guiding a diagnostic or therapeutic instrument towards a target region inside the patient's
5 body.

BACKGROUND OF THE INVENTION

Diagnostic and therapeutic techniques aimed at diagnosing and treating cancerous tumors are known and widely used. Some of them involve the insertion of an instrument such as a needle, from outside the patient into a tumor that is
10 suspected of being cancerous. For example, a biopsy needle commonly is inserted into a tumor to withdraw a tissue sample for biopsy. In brachytherapy, a radioisotope is placed at the tip of a needle, and the tip of the needle is inserted into the tumor to deliver radiation to the tumor with minimal irradiation of the surrounding healthy tissue. Although not common in medical practice,
15 chemotherapeutic agents also may be injected into the tumor using a needle. Such needles are often inserted into the patient utilizing a series of structural images of the patient, such as ultrasound images, images obtained with Magnetic Resonance Imaging (MRI) or Computed Tomography (CT) techniques. These images are acquired before and during the insertion of the instrument, to verify that the
20 instrument is being directed towards the correct target and is bypassing organs such as blood vessels, which should not be penetrated by the instrument.

Since a tumor may include both cancerous tissue and non-cancerous tissue, it is important to be able to direct an instrument specifically to a cancerous portion of a tumor, and to avoid misdiagnosis from the non-cancerous portion of a tumor. In the case of a biopsy, the needle should be directed towards the portion of the tumor that is most likely to be cancerous. In the case of brachytherapy, the needle should be directed towards the cancerous portion of the tumor. Structural imaging modalities, such as CT and MRI, that have enough spatial accuracy and resolution to distinguish and resolve tumors, are nevertheless unable to differentiate cancerous tissue from non-cancerous tissue. Functional imaging modalities, including tomographic nuclear imaging modalities, such as Single Photon Emission Computed Tomography (SPECT) and Positron Emission Tomography (PET), can distinguish cancerous tissue from non-cancerous tissue, but lack the spatial accuracy and resolution that is needed for the accurate positioning of instruments such as biopsy needles and brachytherapy needles.

Techniques for registering a functional image with a structural image to produce a combined image have been developed, and are disclosed, for example in the following publications: M. W. Vannier and D. E. Gayou, "Automated registration of multimodality images", *Radiology*, vol. 169 pp. 860-861 (1988); J. A. Correia, "Registration of nuclear medicine images", *J. Nucl. Med.*, vol. 31 pp. 1227-1229 (1990); J-C Liehn, A. Loboguerrero, C. Perault and L. Demange, "superposition of computed tomography and single photon emission tomography immunoscintigraphic images in the pelvis: validation in patients with colorectal or ovarian carcinoma recurrence", *Eur. J. Nucl. Med.*, vol. 19 pp. 186-194 (1992); F. Thomas et al., "Description of a prototype emission transmission computed tomography imaging system", *J. Nucl. Med.*, vol. 33 pp. 1881-1887 (1992); D. A. Weber and M. Ivanovic, "Correlative image registration", *Sem. Nucl. Med.*, vol. 24 pp. 311-323 (1994); and Hasegawa et al., US Patent No. 5,376,795. All six of these prior art documents are incorporated herein by reference for all purposes as if fully set forth herein. In principle, a sequence of such combined images could be used to direct an instrument to the cancerous portion of a tumor. In practice, the multiple

- 3 -

imaging sessions and registrations that this would require make this solution impractical and possibly dangerous.

Stereotaxis is a known technique for localizing a region inside the body of a patient from outside the body of the patient, and for directing an instrument such as a needle, or a narrow beam of therapeutic radiation, to the target region. The degree of accuracy obtained from stereotaxis is relatively high, so this technique has been considered useful mainly on the brain and the breast. In stereotactic surgery of the brain, a CT localization frame is attached rigidly to the head of a patient and a CT image of the patient's brain is acquired with the CT localization frame in place. The position of the CT localization frame in the CT image is used to position the patient with respect to a surgical instrument utilizing a source of radiation so that the beam or beams of radiation intersects the desired target. Note that the CT localization frame is removed from the patient's head before the therapeutic irradiation commences.

Additionally, in order to access a correct location inside a patient's body with a diagnostic or therapeutic instrument, it is desirable to have exact information on the physical dimensions of the instrument. Using existing tools, such information can be obtained by one of the following means: prompting the user to enter all relevant physical dimensions; keeping a software library of known instruments and prompting the user for a specific model type; or prompting the user to perform a series of actions with a calibration device. Needless to say, these are cumbersome and time-consuming procedures, and require caregiver assistance.

SUMMARY OF THE INVENTION

There is accordingly a need in the art to facilitate the technique of accessing a correct target region inside the patient's body with a diagnostic or therapeutic instrument, aimed at diagnosis and therapy purposes, by providing a novel method and system for guiding the instrument towards the target region, which is not necessarily located in the head or breast.

It is a major feature of the present invention to provide such a method that utilizes a combined image of at least a portion of the patient's body including a target region, which image is obtained by registering a high-resolution structural image and a relatively low-resolution functional image of this portion of the patient's body.

It is a further feature of the present invention to provide such a system that utilizes a guiding device having an indicator associated with a diagnostic or therapeutic instrument for presenting data indicative of a position of the indicator relative to any other point in the chosen portion of the patient's body.

The main idea of the present invention consists of the utilization of a combined image, obtained by registering structural and functional images of at least a portion of the patient's body including a target region, for guiding an instrument (diagnostic or therapeutic) towards the target. The structural and functional images are obtained using, respectively, structural and functional modalities, namely suitable known techniques, and the combined image is obtained by using any known suitable technique, for example, those disclosed in the above publications.

As used herein, the term "*target*" refers to a structurally discrete portion in the patient's body, such as an organ or a tumor, that is suspected of containing diseas (e.g., cancerous tissue). This diseased tissue (target) is surrounded by healthy tissues (e.g., non-cancerous tissue).

As used herein, the term "*instrument*" refers to a diagnostic or treatment instrument that can access and, if desired, be inserted into the target from outside the patient for the purpose of either diagnosis or treatment of a disease. Typical examples of such instruments include biopsy needles and needles for brachytherapy and chemotherapy.

According to one broad aspect of the present invention, there is provided a method for guiding an instrument towards a correct target inside the patient's body, the method comprising the steps of:

- (i) providing an image of at least a portion of the patient's body including said target, wherein said image presents a combined image

– 5 –

of registered structural and functional images of said at least portion of the patient's body;

- (ii) providing data indicative of a position of a location on the instrument relative to any other point in said at least portion of the patient's body; and
- (iii) directing the instrument to said target.

To provide the combined image, the structural and functional images are obtained with, respectively, structural and functional modalities and registered. While directing the instrument towards the target, at least one additional image of the at least portion of the patient's body is preferably acquired with at least one of structural or functional modalities, for obtaining at least one additional combined image. Several additional images may be periodically or continuously acquired, and consequently, several additional combined images be obtained.

The structural and functional images used for obtaining the combined image may be, respectively, high-resolution and relatively low resolution. The resolution of 3-5mm pixel size is considered to be low, and that of less than 1mm pixel size is considered to be high resolution. In this case, the at least one additional image may be a low-resolution functional image or relatively higher resolution structural images (the so-called "medium-resolution" structural image). Alternatively, the structural and functional images used for obtaining the combined image may each be of a low resolution, in which case the at least one additional image is acquired with high-resolution structural modality.

To provide the data indicative of the relative position of the instrument, a guiding device is used having an indicator associated with the instrument.

The guiding device may comprise a frame attachable to the patient's body and a stereotactic guide. The indicator is in the form of at least three markers on the frame. In this case, to provide the combined image, the following steps are performed. The frame is rigidly secured to the patient, and then the high-resolution structural image is acquired using a high-resolution structural imaging modality, such as CT or MRI. This high-resolution structural image includes at least the

- 6 -

portion of the patient's body. The markers are used by taking a series of structural images that covers all of them, since they are located in different planes. To acquire the functional image to be registered with the so-obtained high-resolution structural image, a suitable radiopharmaceutical, that is taken up preferentially by cancerous tissue (i.e., target), is injected into the patient, and the portion of the patient's body that was imaged with the structural modality is again imaged using a lower-resolution functional imaging modality that records radiation emitted by the radiopharmaceutical to acquire an image of the target. The structural image and the functional image are then registered to provide the combined image that shows the relative location of the target relative to other elements in the combined image. In other words, the combined image shows which part of a tumor mass seen in the structural image contains cancer, and where the cancerous areas are located on the high-resolution structural image.

Prior to performing step (iii), the stereotactic guide is rigidly attached to the frame. Since the position of the target (e.g., cancerous tissue) relative to the frame is known, the position of the target relative to the stereotactic guide is also known. The stereotactic guide then is used, under computer control, to guide the instrument, such as a biopsy needle or a brachytherapy needle, to the target, with reference to the pixels of the combined image that represent the markers and the target. The trajectory of the instrument is programmed in advance so that the instrument does not penetrate organs, such as vascular structures, that should not be penetrated.

According to another broad aspect of the invention, there is provided a method for accessing a target in a patient's body with an instrument, the method comprising the steps of:

- (a) providing a guiding device having a frame to be secured to the patient and a stereotactic guide assembly, wherein the frame carries an indicator in the form of at least three markers;
- (b) rigidly securing said frame to the patient;

- 7 -

- (c) imaging at least a portion of the patient's body including the target, using a structural imaging modality, to produce a structural image of the at least portion of the patient's body and at least one of the markers, and acquiring a series of images to image all the markers and estimate their location in said structural image;
- 5
- (d) imaging the at least portion of the patient's body using a functional imaging modality to produce a functional image of the at least portion of the patient's body; and
- (e) registering the functional image with the structural image to produce a combined image,
- 10
- (f) rigidly attaching said stereotactic guide assembly to said frame, and
- (g) directing the instrument to the target, using the stereotactic guide, with reference to said markers as imaged in the combined image.

According to another embodiment of the invention, the guiding device is a so-called tracking system composed of a guiding reference unit providing data indicative of space coordinates of the indicator that is in the form of a sensor attachable to the instrument at its handle portion, and a guiding controller. The latter is interconnected between the indicator and the guiding reference, and is connected to a computer device displaying the combined image. Such a tracking system may be of any known type, e.g., magnetic, optical, inertial, sound-waves, GPS. The construction and operation of the tracking system are known *per se*, and do not form part of the present invention. Therefore, the operation of the tracking system does not need to be specifically described, except to note the following. The controller is capable of tracking the position of a sensor and obtaining the information indicative of six degrees of freedom (i.e., 3 position coordinates and 3 rotation angles). The controller is installed with suitable hardware and is operated by suitable software for performing a signal processing technique and generating data indicative of the sensor's position in the coordinate space defined by the guiding reference. The computer device analyzes this data to generate a graphic

15

20

25

- 8 -

representation of instrument location on the structural or functional image, or direction instructions for guiding the instrument towards the target.

Magnetic tracking systems are based on a magnetic/electronic field transmitter (guiding reference) and a relatively small receiver (indicator). Such a system may, for example, be the miniBIRD model, commercially available from
5 Ascension Technology Corporation. Optical tracking systems apply a visual perception technique that observes either light reflected items or small light emitters, for example POLARIS models, commercially available from Northern Digital Inc.

10 Additionally, the indicator may comprise an identification electronic chip attached to the handle-portion of the instrument. This is actually a chip with an embedded application, such as a miniature electronic memory chip programmed during the manufacture of the specific instrument. The chip may be equipped with a transmitting utility generating and transmitting data indicative of the physical
15 dimensions of the instrument or its corresponding code in accordance with a coded library. Alternatively or additionally, the chip may comprise a magnetic strip or a bar code to be read by a suitable reading head associated with the computer device.

According to another broad aspect of the present invention, there is provided a system for guiding an instrument towards a correct target inside the patient's
20 body, the system comprising:

- a computer device for displaying an image of at least a portion of the patient's body including said target, wherein said displayed image presents a combined image of registered structural and functional images of said at least portion of the patient's body;
- 25 - a guiding device having an indicator associated with said instrument for presenting data indicative of a position of a location on the instrument relative to any other point in said at least portion of the patient's body, said guiding device being connectable to said computer device and operable thereby for directing the instrument to said target.

Preferably, the system also comprises an additional imaging modality capable of acquiring at least one of structural and functional images of said at least portion of the patient's body. This additional imaging modality is operable for acquiring at least one image, used for obtaining at least one additional combined
5 image (a so-called "updated combined image"). This at least one additional combined image is utilized, while directing the instrument towards the target.

Although the scope of the present invention includes the diagnosis and treatment of any diseased tissue, the present invention is described below in terms of the primary application thereof, the diagnosis and treatment of cancer.

10 BRIEF DESCRIPTION OF THE DRAWINGS

In order to understand the invention and to see how it may be carried out in practice, a preferred embodiment will now be described, by way of non-limiting example only, with reference to the accompanying drawings, in which:

Fig. 1 shows a patient wearing a frame;

15 Figs. 2A to 2C schematically illustrate axial sections of a Ga-67, a CT and a combined image of a chest of a patient;

Fig. 3 shows the patient of FIG. 1 with a stereotactic guide attached to the frame;

Fig. 4 illustrates the main constructional parts of a system according to
20 another embodiment of the invention;

Fig. 5 illustrates another feature of the present invention suitable to be used in the embodiment of Figs. 1 and 3, or the embodiment of Fig. 4;

Figs. 6a and 6b illustrate two more examples of an indicator suitable to be used in the present invention; and

25 Fig. 7 illustrates some more features of a method and system according the invention.

DETAILED DESCRIPTION OF A PREFERRED EMBODIMENT

Referring to Figs. 1-3, there is illustrated one embodiment of the present invention utilizing a method of stereotactic diagnosis and treatment of diseased tissue. Fig. 1 shows a patient **10** wearing a rigid frame **12**. By virtue of being snugly fitted to the shoulders, waist and groin of patient **10**, frame **12** is rigidly secured to patient **10**. Frame **12** bears thereon three markers **14** (constituting an indicator) that include a material that shows up well in a high-resolution structural image of the patient **10** and frame **12**. For example, if CT is used for structural imaging, markers **14** are lead blocks. If MRI is used for structural imaging, markers **14** are hollow plastic blocks filled with a solution of Gd-DTPA. Frame **12** also bears three attachment points **16** for a stereotactic guide. A high-resolution structural image of the portion of patient **10** that contains the target is acquired while patient **10** wears frame **12** as shown in Fig. 1.

Three is the minimum number of markers **14** that is needed for accurately recording the relative positions of frame **12** and the internal tissues of patient **10** in three dimensions in the structural image. Markers **14** are shown in Fig. 1 as three blocks only for illustrational clarity. Any suitable marker geometry or form may be used, for example, vertical and diagonal rods, as are used in the BRW CT localization frame commercially available from Radionics, Inc., of Burlington MA and from Sofamor Danek, of Elektra, Sweden, for stereotactic treatment of the patient's brain. The positioning of markers **14** and attachment points **16** on frame **12** in Fig. 1 also is only illustrative, as an example of appropriate positions of markers **14** and attachment points **16** for treatment of the abdomen of patient **10**.

Subsequent to or simultaneously with the acquisition of a high-resolution structural (e.g., CT or MRI) image of the portion of patient **10** that includes the target (while the patient wears the frame), a lower resolution functional (e.g., nuclear medicine) image of the same portion of patient **10** is acquired for the purpose of imaging the target in the entire portion imaged by the structural modality. If the disease under treatment is cancer, then the preferred imaging

- 11 -

modality is nuclear imaging, and the patient is injected before imaging with a radiopharmaceutical that is preferentially taken up by cancerous tissue. Examples of such radiopharmaceuticals include Ga-67, Tc-99m MIBI, Tl-201, F-18 fluorodeoxyglucose and In-111 octreotide. The most preferred nuclear imaging modalities are tomographic modalities such as SPECT and PET. The functional and structural images then are registered, for example as described in the paper by Weber and Ivanovic cited above, to produce a combined image.

Fig. 2A is a schematic illustration of an axial section of a Ga-67 image I_{func} of a chest of a cancer patient, showing a tumor T containing a lymphoma that constitutes the target TG to be accessed by an instrument (not shown). Fig. 2B is a schematic illustration of an axial section of a CT image I_{struct} of the same patient's chest. A portion P of the patient's body including the tumor T is imaged. The target TG is not seen in the structural image I_{struct} , since there is typically no visual contrast in such image between the lymphoma and the rest of the tumor. What can be seen in such a structural image are organs and tissues, generally at OR , surrounding the tumor T (and consequently the target to be detected), and typically one of the markers 14 on the frame. Although three markers are presented in the drawings as seen in the structural image, two of them are shown in dotted lines, since the markers are located in different planes, and only one of them will be seen in such a sectional view. Fig. 2C is an axial section of a combined image I_{com} , showing the functional image I_{func} of Fig. 2A registered on the structural image I_{struct} of Fig. 2B. Any known suitable technique can be used for registering images of Figs. 2A and 2B to obtain the combined image of Fig. 2C, for example the techniques described in the above-indicated publications. Biopsy and therapy directed towards the tumor should be aimed specifically at the lymphoma.

Fig. 3 shows patient 10 with a stereotactic guide 18 firmly and rigidly attached to frame 12 at attachment points 16 , and with a diagnostic or therapeutic instrument 20 , such as a biopsy needle or a brachytherapy needle, mounted in stereotactic guide 18 in its ready-for-insertion position to be inserted into the abdomen of patient 10 under the control of a computer device 24 .

- 12 -

Computer **24** is equipped with suitable hardware and operated by suitable software for sending control signals, including the relevant Cartesian coordinates, to stereotactic guide **18** via suitable signal communication means, for example electrical connection such as a cable **22**. It should be understood, although not specifically shown, that wireless connection could be used. Computer **24** also includes a suitable display mechanism, such as a video terminal, for displaying the combined image.

A physician programs the trajectory of instrument **22** in computer **24** in advance, with reference to the position of the target **TG** and the other internal organs **OR** of patient **10**, and with reference to markers **14**, as seen in the combined image I_{com} . Computer **24** is installed with suitable software that transforms data indicative of the coordinate system of the combined image, as defined by markers **14**, into the coordinate system of stereotactic guide **18**. This software is used to transform the coordinates of the trajectory, which is defined by the physician in the coordinate system of the combined image, into the coordinate system of stereotactic guide **18**, to enable stereotactic guide **18** to steer instrument **20** along the desired trajectory. The physician designs the trajectory to avoid vascular structures and other organs that should not be penetrated by instrument **20**.

To assist the physician in recognizing and avoiding vascular structures such as blood vessels, another functional image of the portion of patient **10** that includes the target is acquired, for the purpose of imaging the blood vessels. The preferred imaging modality for imaging vascular structures is Tc-99m labeled red blood cells SPECT. For this purpose, patient **10** is first injected with Tc-99m, to label the red blood cells of patient **10**. The SPECT image of the vascular structures is registered with the structural image initially obtained and utilized in the initial combined image shown in Fig. 2C, and a resulting second combined image is displayed by computer **24** and is used by the physician in planning the trajectory of instrument **20** to avoid penetration of the imaged vascular structures.

Similarly, to assist the physician in recognizing and avoiding organs such as the kidneys, another functional image of the portion of patient **10** that includes the

target is acquired. In the specific case of the kidneys, this second functional image is a SPECT image obtained using Tc-99 DMSA. The SPECT image of the organ or organs is registered with the structural image, and the resulting second combined image is displayed by computer 24 and is used by the physician in planning the trajectory of instrument 20 to avoid penetration of the imaged organs. To prevent errors in planning the trajectory of instrument 20, computer 24 is programmed to avoid penetration of blood vessels and organs with a high blood pool, and other organs that should not be penetrated, such as the gut, the kidneys, the pancreas and the heart.

10 It should be understood that more than one additional combined image can be obtained, the number of these additional images depending on a specific application, e.g., a target to be accessed. A physician himself decides how many updates of the initial combined images are needed for successfully guide the instrument towards the target.

15 In the above-described example of the present invention, the biopsy needle guidance utilizes the stereotactic guide assembly, with reference to the diseased portion of the patient's body and to the markers as imaged on the first combined image. In other words, in the above-described example, a guiding device is constituted by the frame with markers and by the stereotactic guide assembly. However, other guidance and motion tracking systems are suitable as well. Such systems are, but not limited to magnetic and optical systems.

Reference is made to Fig. 4, illustrating the main components of a system, generally designated 100, according to another embodiment of the invention. System 100 is composed of an indicator 126 appropriately attached to a handle portion 122 of an instrument 120, a guiding reference unit 128 and a guiding controller 130 connected to the computer 24.

As indicated above, such a system may be of magnetic or optical kind, for example, commercially available from Ascension Technology Corporation and Northern Digital Inc., respectively. Generally speaking, the guiding reference unit 128 and the indicator 126 operate together to generate data indicative of the

– 14 –

indicator position in a 6D coordinate space (3 position coordinates and 3 rotation angles) and transmit this data to the guiding controller 130. The latter transmits corresponding data to the computer device 24, which registers this data with the combined image to generate a graphic representation of the instrument's location
5 on the structural or functional image or direction instructions for guiding the instrument 120 towards the target, as described above.

Turning now to Fig. 5, there is illustrated an instrument 220 having a handle portion 222 formed with an identification chip 226. As indicated above, a major factor in the accuracy of the system of the kind specified is exact information on
10 the physical dimensions of a diagnostic or therapeutic instrument associated with a guiding device. To this end, the diagnostic or therapeutic instrument 220 according to the invention is equipped with the chip 226 with an embedded application enabling the identification of the physical dimensions of the specific instrument. The chip provides data indicative of the instrument's physical parameters, which
15 may be dimensions themselves, or coded data that can be identified by the software installed in the computer 24 (i.e., library storing information corresponding to various Serial Numbers of diagnostic and therapeutic instruments manufactured by various manufacturers). The computer 24 itself may have a special utility for communicating with the embedded application of the chip.

20 According to the present invention, diagnosis and/or treatment are performed with respect to an image of the target region in the patient's body that combines a high-resolution structural image, such as a CT or MRI image, with a lower resolution functional image, such as a nuclear image. The combined image may be used to assist the caregiver in locating the instrument with respect to the
25 target. Pieces of materials that are clearly shown in one of the modalities may be used to gain information in the combined image. Such materials are, but not limited to, radioactive emitters that are clearly seen by means of the nuclear medicine image, and lead capsules that are highly visible in a CT image. Such pieces can be attached to known locations on the therapeutic instrument, thereby serving as
30 indicators. These indicators are useful in the procedure navigation process, where

– 15 –

the physician inserts the instrument toward the target. At the end of the procedure there is a verification phase, where the physician validates the location of the instrument with respect to the target. During the verification phase both the tissue and the highlight indicator are clearly seen in the combined image. This increases
5 the degree of confidence that the procedure instrument was correctly applied.

Fig. 6A shows the main principles of the above concept. Here, such an indicator **326** (e.g., radioactive emitters) is attached to a location on an instrument **320** close to its handle portion **322**.

Fig. 6B illustrates an example where treatment of the target is needed. To
10 this end, a therapeutic instrument **420** is at its distal end formed with a suitable material **422** that can be clearly seen in an image of one of the modalities to gain information in the combined image. Thus, the therapeutic instrument **420** is initially inserted by its distal end into a vessel containing material **422**, and is then directed towards the target **TG**. Such materials are, but not limited to, radioactive materials
15 that are clearly seen by means of the nuclear medicine image, and iodine that is highly visible in a CT image. The highlight material may also be mixed with the therapeutic chemical in advance. The highlight materials are injected together with therapeutic chemical substances and are used to track the absorption of the substances with respect to the tumor while minimizing damage to the surrounding
20 healthy tissue.

As indicated above, diagnosis is performed with respect to an image of the target region of the patient that combines a high-resolution structural image, such as a CT or MRI image, with a lower resolution functional image, such as a nuclear image. For various reasons, a physician may prefer to perform the clinical
25 procedure under single modality equipment that may be different from the equipment originally used to make the combined image. In this case, the combined image is made of a relatively high-resolution structural image, lower resolution functional image, and another image that may be either structural or functional of a different resolution. For example, a low-resolution PET image may be combined
30 with a medium-resolution CT image, which images are collected during a

– 16 –

preliminary diagnostic procedure. The actual procedure is carried out under a high-resolution CT or MRI imaging, that was designed for such procedures.

The above concept is schematically illustrated in Fig. 7, showing a system 500 utilizing low-resolution CT imaging modality (as compared to that used during the instrument insertion procedure) and low-resolution PET imaging modality, generally at 502, that obtain a combined image of a portion of the patient's body including a target and transmit data to a computer device 24 and to a high-resolution CT modality 504 through a computer network. A guiding device 506 associated with a diagnostic or therapeutic instrument 520 and coupled to the computer 24, is used for guiding the instrument towards the target with simultaneous image acquisition with the high-resolution CT imaging modality 504.

Those skilled in the art will readily appreciate that various modifications and changes can be applied to the preferred embodiment of the invention as hereinbefore described without departing from its scope defined in and by the appended claims.

CLAIMS:

1. A method for guiding an instrument towards a correct target inside the patient's body, the method comprising the steps of:
 - 5 (i) providing an image of at least a portion of the patient's body including said target, wherein said image presents a combined image of registered structural and functional images of said at least portion of the patient's body;
 - (ii) providing data indicative of a position of a location on the instrument relative to any other point in said at least portion of the patient's
10 body; and
 - (iii) directing the instrument to said target.
2. A method according to Claim 1, wherein the registered structural and functional images used for providing the combined image are obtained with, respectively, structural and functional modalities.
- 15 3. A method according to Claim 2, wherein the structural modality is Computed Tomography (CT).
4. A method according to Claim 2, wherein said structural modality is Magnetic Resonance Imaging (MRI).
5. A method according to Claim 2, wherein the functional modality is Single
20 Photon Emission Computed Tomography (SPECT).
6. A method according to Claim 2, wherein the functional modality is and Positron Emission Tomography (PET).
7. A method according to Claim 1, wherein the structural and functional images used for providing said combined image are, respectively, of higher and
25 lower resolution, as compared to each other.
8. A method according to Claim 1, wherein at least one additional image of said at least portion of the patient's body is acquired, and at least one additional combined image is obtained, while directing the instrument towards the target.

- 18 -

9. A method according to Claim 8, wherein the combined image is provided by registering a high-resolution structural image with relatively low resolution functional image, and said at least one additional image is a low-resolution functional image.

5 10. A method according to Claim 8, wherein the combined image is provided by registering a high-resolution structural image with relatively low resolution functional image, and said at least one additional image is a high-resolution structural image.

11. A method according to Claim 8, wherein the combined image is provided
10 by registering a low-resolution functional image with a low-resolution structural image, and said at least one additional image is a relatively high-resolution structural image.

12. A method according to Claim 1, wherein the step (i) and (ii) comprise:

- 15 - attaching a frame to the patient's body in a rigidly secured position, the frame carrying an indicator in the form of at least three markers;
- acquiring the structural image using a structural imaging modality, the acquired structural image including at least the portion of the patient's body and at least one of the markers, thereby determining a position of any point in said structural image relative to the frame;
- 20 - acquiring the functional image;
- registering the acquired structural and functional images and providing said combined image showing a location of the target relative to other elements in the combined image;
- rigidly attaching a stereotactic guide assembly to said frame, and
25 determining a position of the target relative to the stereotactic guide.

13. A method for accessing a target in a patient's body with an instrument, the method comprising the steps of:

- 30 (a) providing a guiding device having a frame to be secured to the patient and a stereotactic guide assembly, wherein the frame carries an indicator in the form of at least three markers;

– 19 –

- (b) rigidly securing said frame to the patient;
- (c) imaging at least a portion of the patient's body including the target, using a structural imaging modality, to produce a structural image of the at least portion of the patient's body, and acquiring a series of images to image all the markers and estimate their location in said structural image;
- (d) imaging the at least portion of the patient's body using a functional imaging modality to produce a functional image of the at least portion of the patient's body; and
- (e) registering the functional image with the structural image to produce a combined image,
- (f) rigidly attaching said stereotactic guide assembly to said frame, and
- (g) directing the instrument to the target, using the stereotactic guide, with reference to said markers as imaged in the combined image.

15 **14.** A system for guiding an instrument towards a correct target inside the patient's body, the system comprising:

- a computer device for displaying an image of at least a portion of the patient's body including said target, wherein said displayed image presents a combined image of registered structural and functional images of said at least portion of the patient's body;
- a guiding device having an indicator associated with said instrument, said guiding device being operable for presenting data indicative of a position of a location on the instrument relative to any other point in said at least portion of the patient's body, said guiding device being connectable to said computer device and operable thereby for directing the instrument to said target.

25 **15.** A system according to Claim 14, wherein the guiding device comprises a frame attachable to the patient's body and a stereotactic guide assembly attachable to the frame, said frame carrying said indicator in the form of at least three markers to be imaged in the combined image.

30

– 20 –

16. A system according to Claim 14, wherein said guiding device is a position tracking system capable of providing data indicative of six degrees of freedom for a movement of the instrument.
17. A system according to Claim 16, wherein said position tracking system
5 comprises a guiding reference unit providing data indicative of 3 position coordinates and 3 rotation angles of the indicator in the form of a sensor attached to the instrument, and a guiding controller connected to said computer device displaying the combined image.
18. A system according to Claim 17, wherein the tracking system is of a
10 magnetic type.
19. A system according to Claim 17, wherein the tracking system is of an optical type.
20. A system according to Claim 14, wherein the indicator comprises an identification chip attached to a handle-portion of the instrument, said identification
15 providing information indicative of physical dimensions of the instrument.
21. A system according to Claim 14, further comprising an additional imaging modality capable of acquiring at least one of structural and functional images of said at least portion of the patient's body, said computer device being operable to use the at least one additional image for obtaining and displaying at least one
20 additional combined image.
22. A system according to Claim 14, wherein the indicator at a predetermined location thereon carries a highlight material of a kind to be imaged in at least one of structural and functional images.
23. A system according to Claim 22, wherein said predetermined location is a
25 distal end of the instrument, said highlight material being mixed with a therapeutic substance, thereby enabling treatment of the target with the therapeutic substance.

1/6

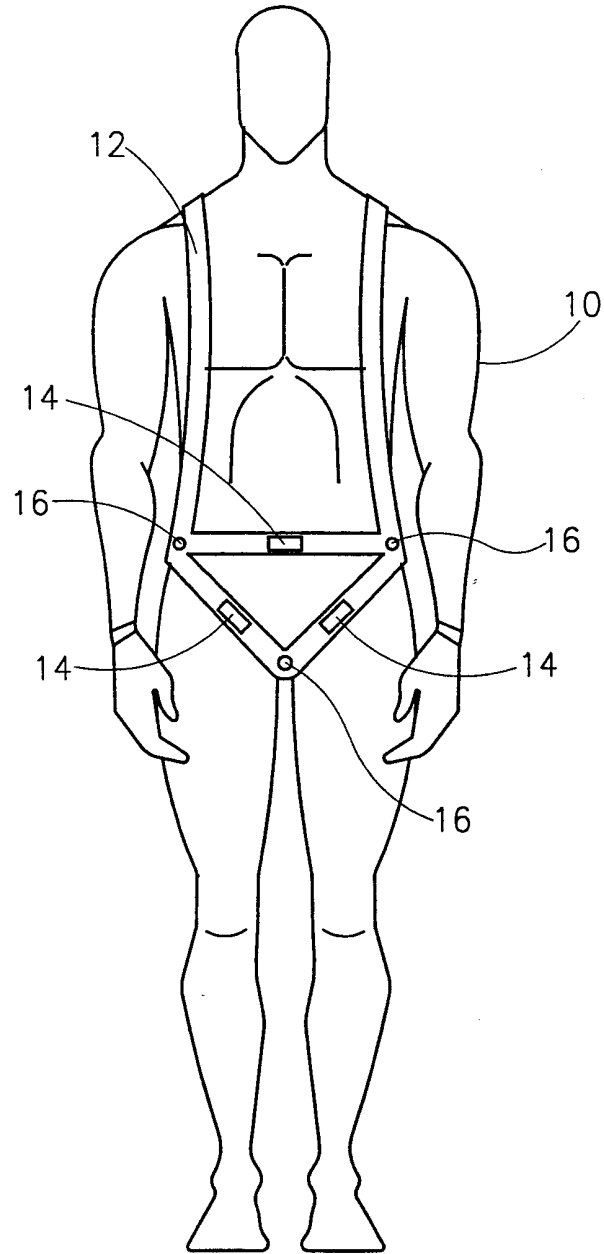

FIG.1

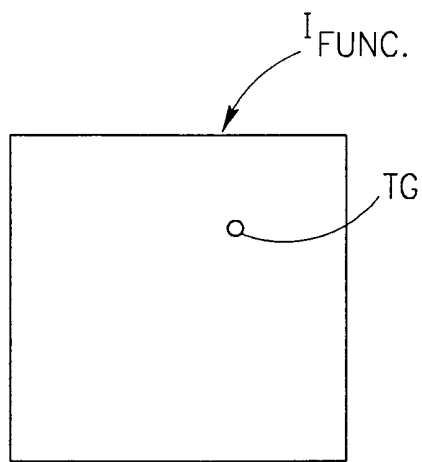

FIG. 2A

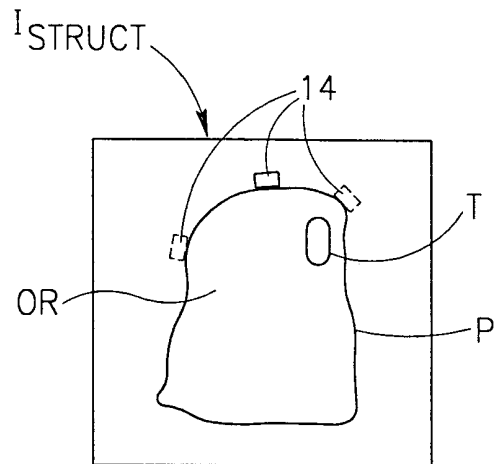

FIG. 2B

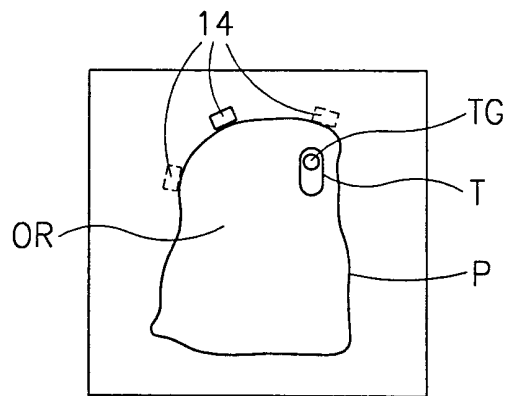

FIG. 2C

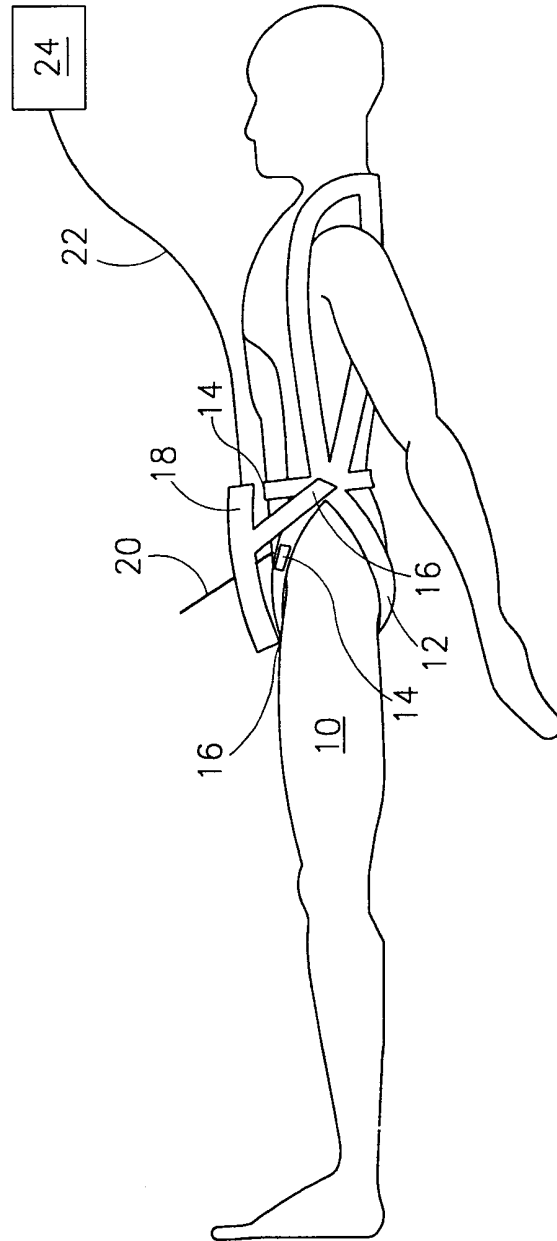
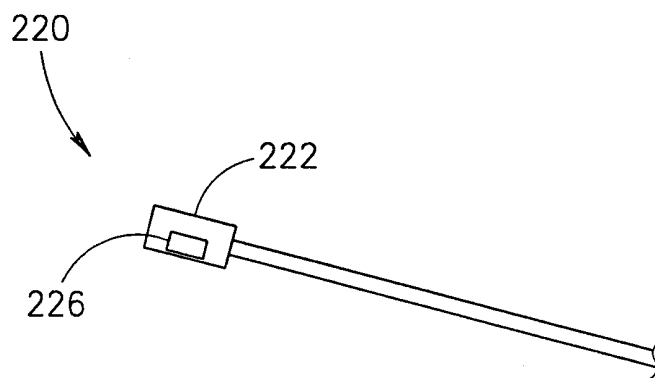
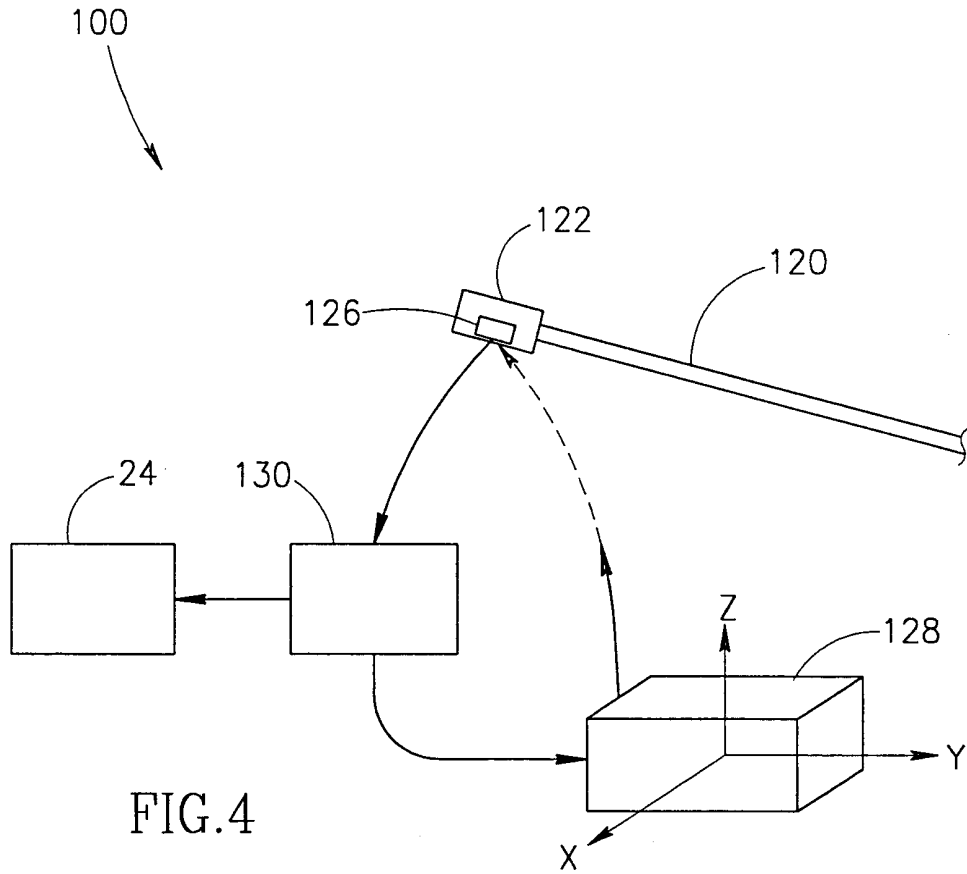

FIG.3



5/6

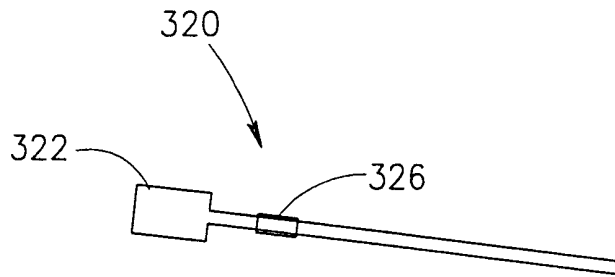

FIG. 6A

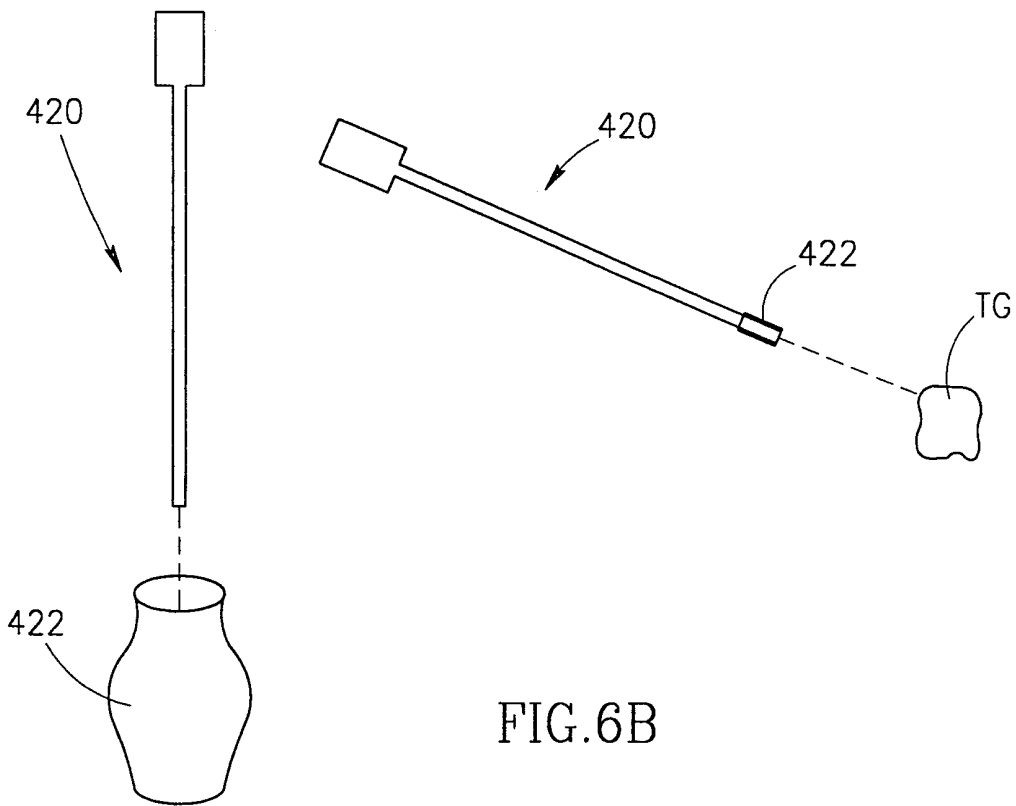

FIG. 6B

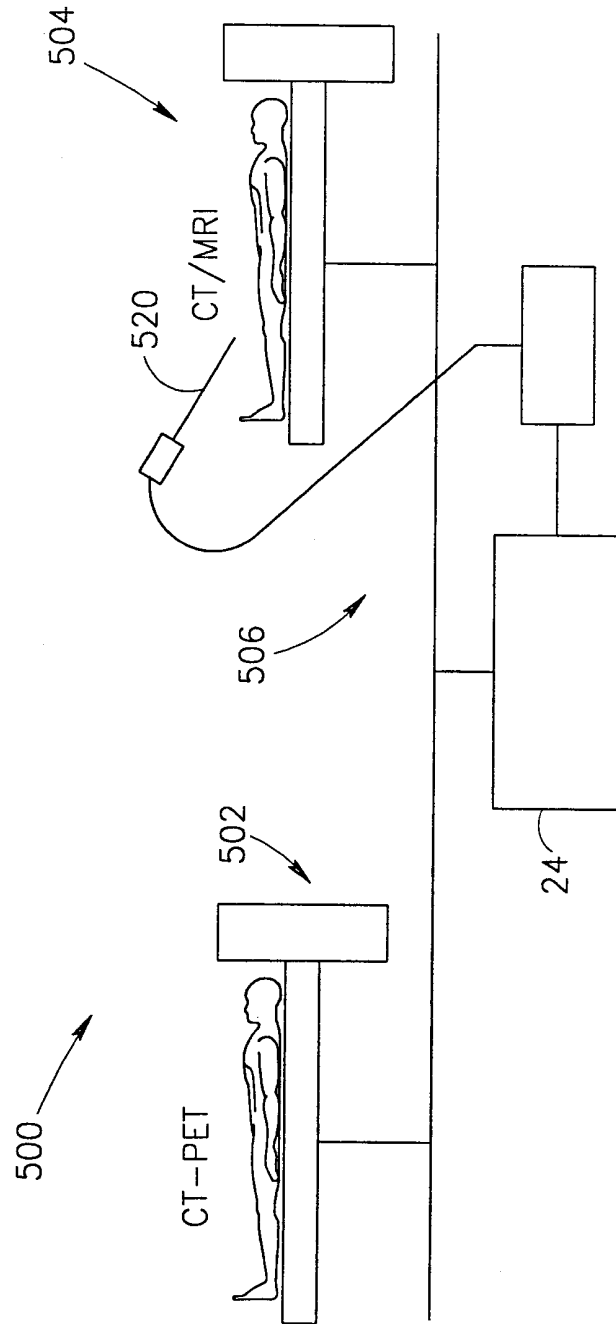

FIG. 7