



US 20190200830A1

(19) **United States**

(12) **Patent Application Publication**
CROUCH et al.

(10) **Pub. No.: US 2019/0200830 A1**

(43) **Pub. Date: Jul. 4, 2019**

(54) **CLEANING APPLIANCE**

A47L 9/04 (2006.01)

A47L 9/06 (2006.01)

A47L 9/10 (2006.01)

(71) Applicant: **Dyson Technology Limited**, Wiltshire (GB)

(52) **U.S. Cl.**

(72) Inventors: **Jeremy William CROUCH**, Swindon (GB); **Alexander Michael Campbell-Hill**, Wotton-Under-Edge (GB)

CPC *A47L 9/1683* (2013.01); *A47L 9/322* (2013.01); *A47L 9/04* (2013.01); *A47L 9/165* (2013.01); *A47L 9/102* (2013.01); *A47L 9/1608* (2013.01); *A47L 9/0693* (2013.01)

(73) Assignee: **Dyson Technology Limited**, Wiltshire (GB)

(57) **ABSTRACT**

(21) Appl. No.: **16/232,556**

(22) Filed: **Dec. 26, 2018**

(30) **Foreign Application Priority Data**

Dec. 30, 2017 (GB) 1722302.5

Publication Classification

(51) **Int. Cl.**

A47L 9/16 (2006.01)

A47L 9/32 (2006.01)

A cleaning appliance includes a dirt separator for separating dirt from an airflow, the dirt separator including a bin for collecting dirt separated from the airflow, the bin including a bin lid having a closed configuration in which the dirt is retained in the bin, and an open configuration for the removal of dirt from the bin. The cleaning appliance further including an inlet, the inlet extending through an opening in the bin lid, and the inlet including an attachment interface. The cleaning appliance further includes an interlock mechanism to prevent the bin lid from being opened when an attachment is connected to the attachment interface.

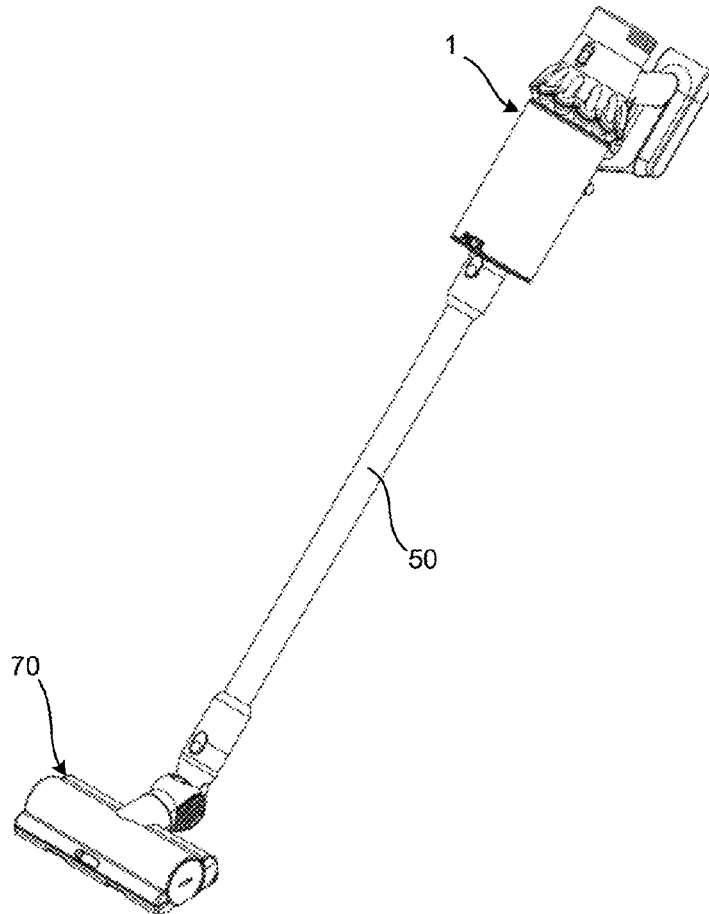

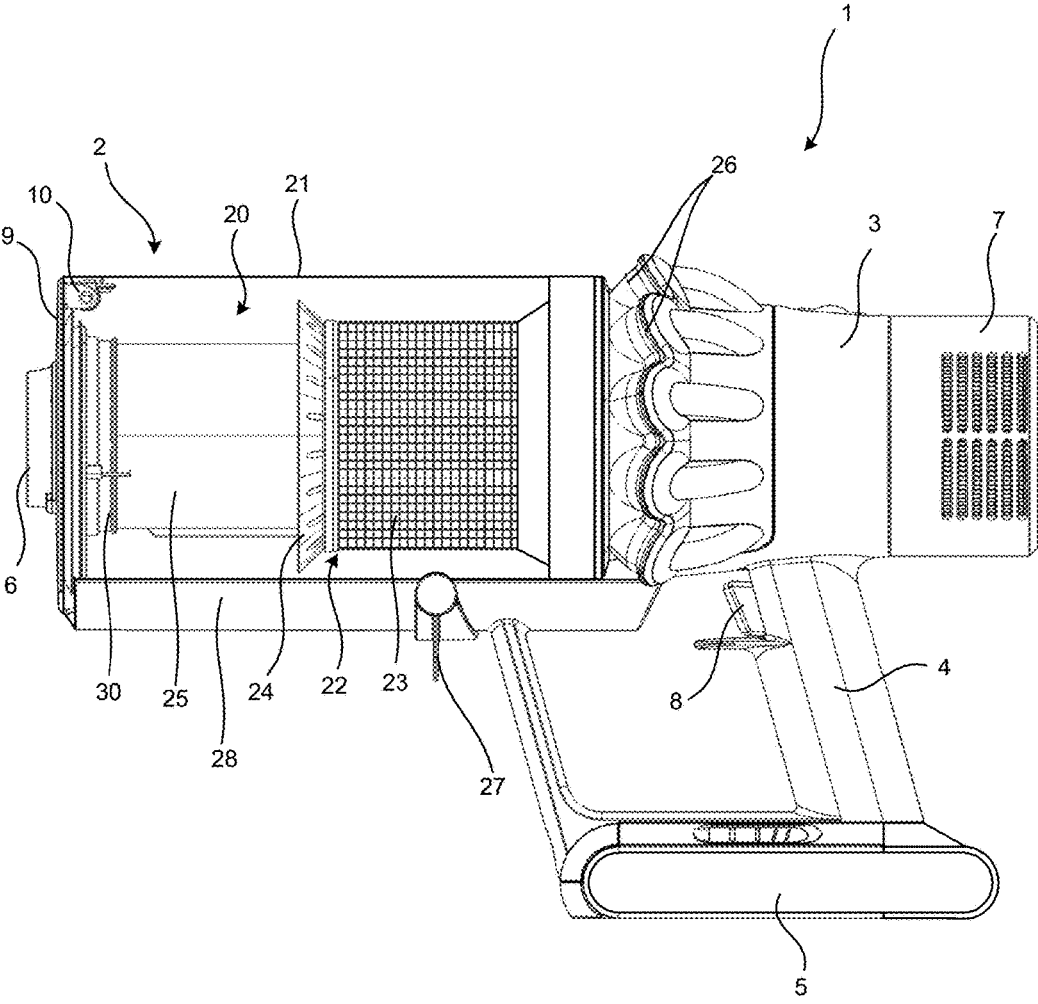

Fig. 1

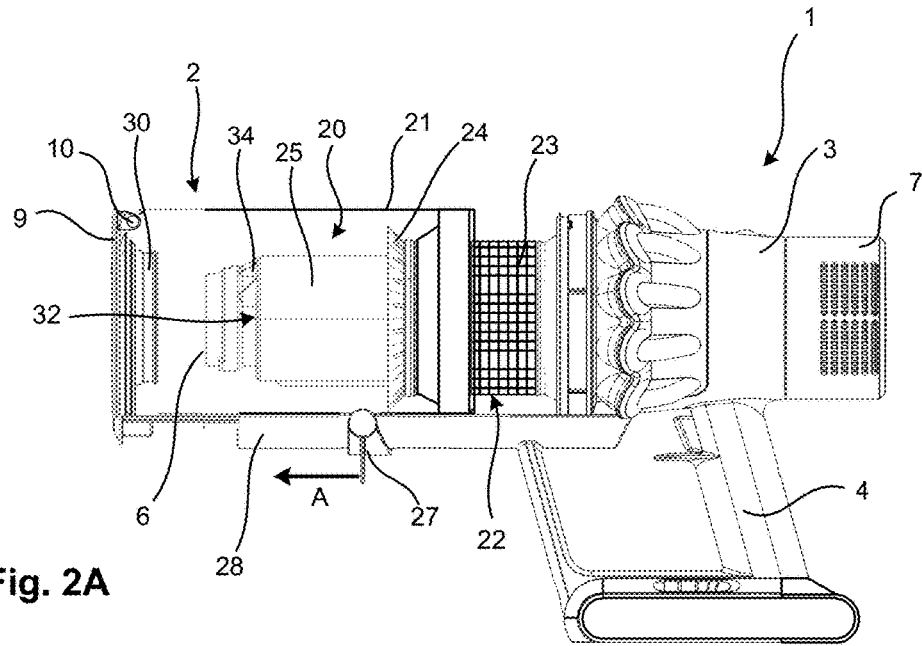

Fig. 2A

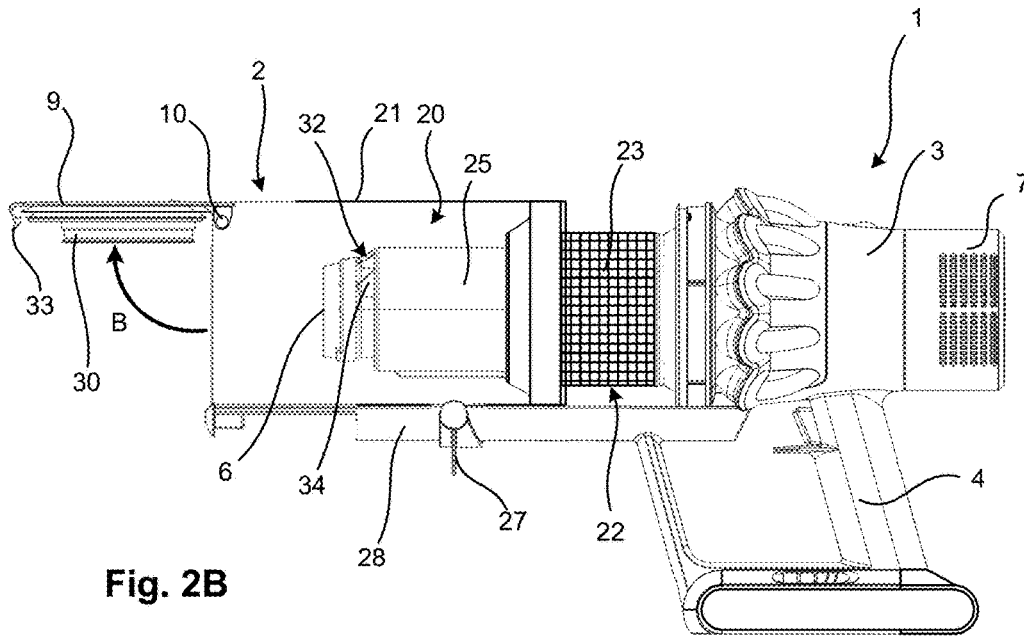

Fig. 2B

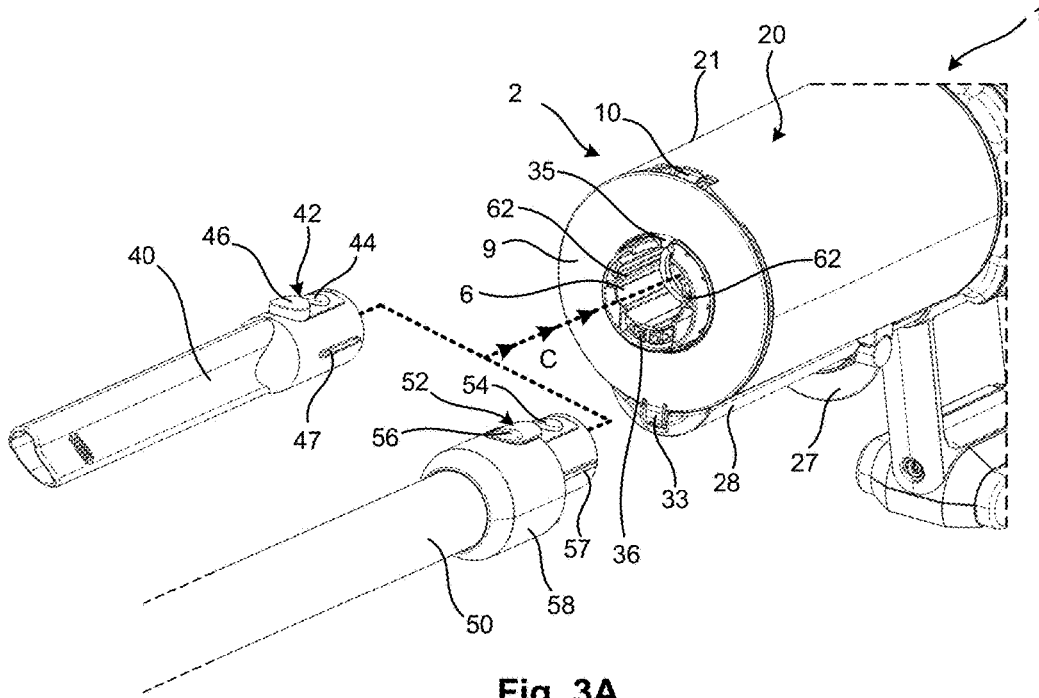

Fig. 3A

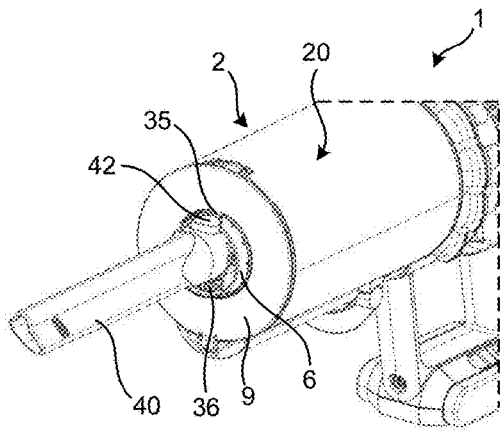

Fig. 3B

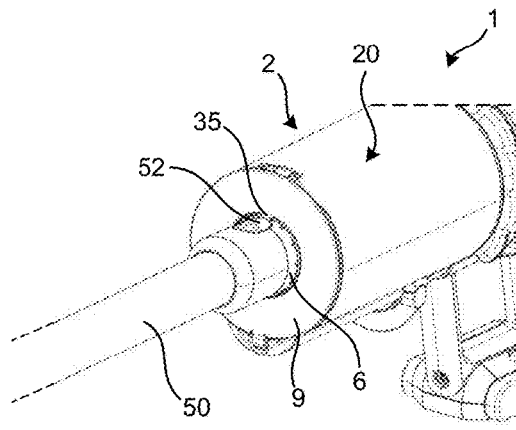

Fig. 3C

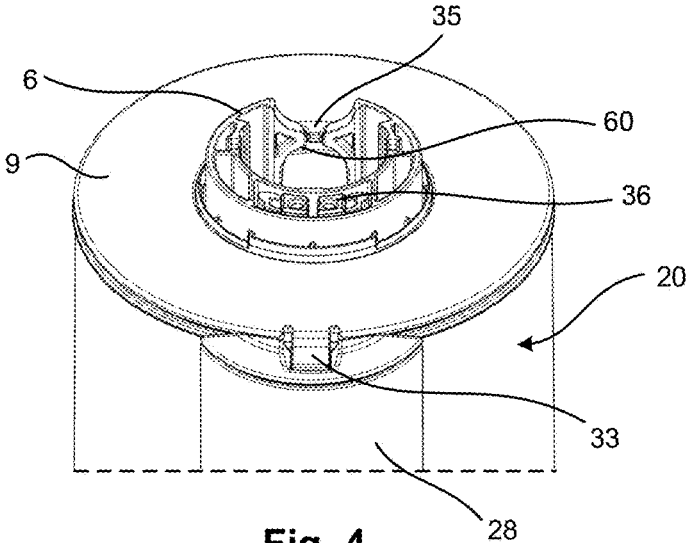

Fig. 4

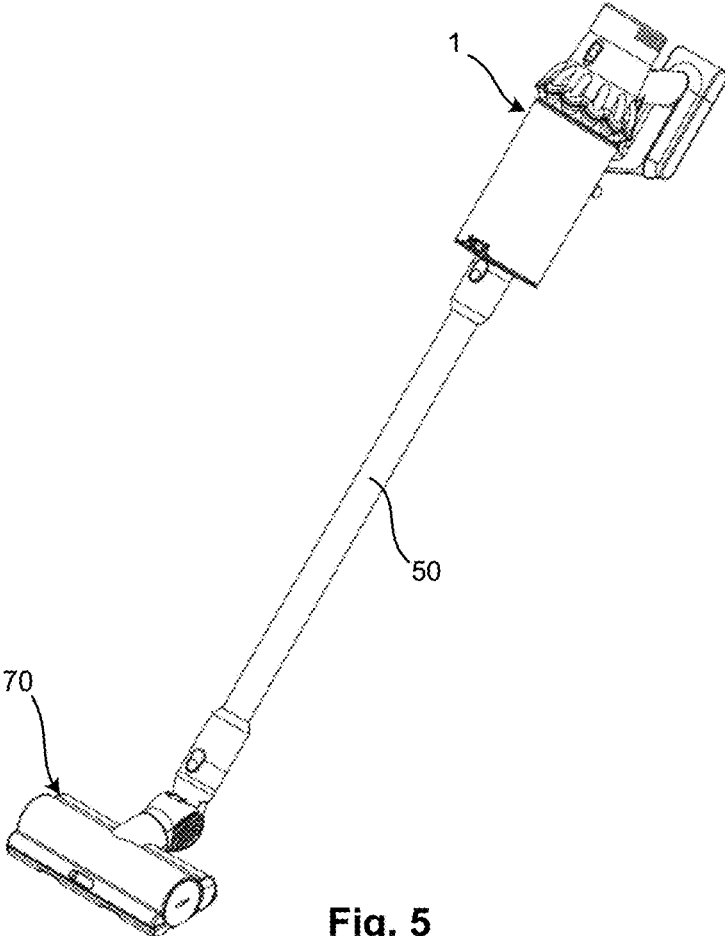

Fig. 5

CLEANING APPLIANCE

REFERENCE TO RELATED APPLICATIONS

[0001] This application claims the priority of United Kingdom Application No. 1722302.5, filed Dec. 30, 2017, the entire contents of which are incorporated herein by reference.

FIELD OF THE INVENTION

[0002] The present invention relates to a cleaning appliance.

BACKGROUND OF THE INVENTION

[0003] Improvements to vacuum cleaners are always being sought. In particular improvements that make it easier for a user to use the vacuum cleaner, and to encourage the user to use the vacuum cleaner in the best way possible. It is desirable to ensure that the user is not able to carry out any operations which could result in a fault that needs to be resolved or requires troubleshooting.

SUMMARY OF THE INVENTION

[0004] A first aspect of the present invention provides a cleaning appliance comprising a dirt separator for separating dirt from an airflow, the dirt separator comprising a bin for collecting dirt separated from the airflow, the bin comprising a bin lid having a closed configuration in which the dirt is retained in the bin, and an open configuration for the removal of dirt from the bin. The cleaning appliance further comprises an inlet, the inlet extending through an opening in the bin lid, the inlet comprising an attachment interface. The cleaning appliance further comprises an interlock mechanism to prevent the bin lid from being opened when an attachment is connected to the attachment interface.

[0005] As a result it is not possible to initiate a bin emptying, or bin removal procedure while there is an attachment connected to the cleaning appliance. Because the inlet extends through an opening in the bin lid, any attachment connected to the cleaning appliance could hinder full opening of the bin lid, and as a result the bin lid and the attachment itself would act to obstruct the ejection of dirt and dust from the bin. Therefore it is beneficial to prevent the in opening process from being started while an attachment is connected to the inlet.

[0006] The attachment interface may comprise a formation for engaging with a catch provided on an attachment. This allows the attachment to be removably fixed to the vacuum cleaner during use, but allows for easy removal of the attachment when it is no longer required.

[0007] The interlock mechanism may comprise a protrusion on the bin lid that extends radially inwards from the opening, the protrusion forming an abutment surface for abutting with a corresponding abutment surface on an attachment. This provides a cheap and simple but effective interlock mechanism which is unlikely to fail.

[0008] The protrusion may extend into the attachment interface. When an attachment is connected to the attachment interface, the abutment surface on the bin lid may abut with a catch on the attachment, the catch acting as the corresponding abutment surface on the attachment. As a result, any attachment that comprises a catch to fix it to the

vacuum cleaner, no matter what shape the attachment is, will abut with the interlock mechanism, and prevent the bin from being opened when attached.

[0009] The attachment may be one of a wand, an extension hose, and a cleaning tool.

[0010] The bin lid may be hingedly attached to a side wall of the bin and may be pivotable between the closed configuration and the open configuration. As a result, the bin lid can be opened without needing to be completely detached from the vacuum cleaner, resulting in an easier bin emptying procedure for a person using the vacuum cleaner.

[0011] The bin may be movable relative to the air inlet, and the interlock mechanism may prevent any movement of the bin when an attachment is connected to the attachment interface. The bin may be movable in this way such that the bin can be completely from the vacuum cleaner, or the movement of the bin may be part of the bin opening procedure, and therefore prevention of the bin from moving, in addition to the prevention of the bin lid from opening, is advantageous for the same reasons mentioned above.

[0012] The cleaning appliance may be a handheld vacuum cleaner.

[0013] A wand and cleaner head may be connected to the attachment interface to form a stick vacuum cleaner.

BRIEF DESCRIPTION OF THE DRAWINGS

[0014] In order that the present invention may be more readily understood, embodiments of the invention will now be described, by way of example, with reference to the following accompanying drawings, in which:

[0015] FIG. 1 is a handheld vacuum cleaner;

[0016] FIGS. 2A and 2B show the vacuum cleaner of FIG. 1 at different stages during a bin opening procedure;

[0017] FIGS. 3A, 3B and 3C show the connection of attachments to the vacuum cleaner of FIG. 1;

[0018] FIG. 4 is an upwards view of the inlet of the vacuum cleaner of FIG. 1; and

[0019] FIG. 5 shows a stick vacuum cleaner.

DETAILED DESCRIPTION OF THE INVENTION

[0020] FIG. 1 shows a cleaning appliance in the form of a handheld vacuum cleaner 1 having a dirt separator 2, a main body 3, a handle 4, a power source in the form of battery pack 5, and an inlet 6. At the rear of the vacuum cleaner 1, attached to the main body 3, is a filter assembly 7. The vacuum cleaner 1 is operated by the trigger 8 in the handle 4.

[0021] The dirt separator 2 has a first separation stage and a second separation stage. The first separation stage comprises a cylindrical outer wall 21 which defines a bin 20. A cylindrical inner wall 25 defines a fine dust collection chamber which is positioned inside the bin 20. A closure member in the form of a bin lid 9 is hingedly attached to the outer wall 21 of the dirt separator 2 at hinge 10. The bin lid 9 is pivotable about the hinge 10 between an open position in which dust and dirt can escape from open ends of the bin 20 and fine dust collection chamber, and a closed position in which the bin lid 9 seals the open ends of both the bin 20 and fine dust collection chamber. The bin lid 9 comprises a seal 30 which seals against the inner wall 25. A central portion of the bin lid 9 comprises a hole or opening through which the suction inlet 6 protrudes.

[0022] Inside the bin 20 is a shroud 22 comprising a cylindrical screen 23 and a shroud skirt 24. During operation, air is drawn into the vacuum cleaner 1 through the inlet 6 by a fan motor housed within the main body 3. The dirt-laden air enters the bin 20 through a separator inlet (not shown) in the side wall of the shroud 22 which is joined to the inlet 6 by an inlet duct extending between the two, the inlet duct extending through the inside of the fine dust collection chamber. The air spirals around the inside of the bin 20, and centrifugal forces separate out larger dirt particles from the airflow which settle in the bin 20. The shroud screen 23 comprises a plurality of perforations through which air exits the first separation stage.

[0023] The second separation stage comprises a plurality of cyclone bodies 26. The air passes through the cyclone bodies 26 which separate any remaining dirt and dust from the airflow. The dirt and dust separated in the second separation stage collects in the fine dust collection chamber which is defined by the inner wall 25. Cleaned air exits the cyclones 26, passes through the fan motor in the main housing 3 and then is expelled from the vacuum cleaner 1 through the filter assembly 7.

[0024] In order to empty the bin 20 and the fine dust collection chamber, the bin lid 9 can be opened. FIGS. 2A and 2B show the vacuum cleaner 1 at different stages during a bin emptying procedure. The dirt separator 2 is provided with a bin opening actuator 27 which is fixed to the outer wall 21. When the bin opening actuator 27 is pushed in a direction away from the handle 4, as represented by arrow A in FIG. 2A, this causes the bin 20 (i.e. both the outer wall 21 and the bin lid 9) to slide along the runner portion 28 of the vacuum cleaner 1 in the same direction. The shroud 22, inner wall 25, and the inlet 6 remain stationary as they are fixed to the main body 3. The seal 30 is separated from the inner wall 25, revealing the open end of the second dirt collection chamber 32. Once the outer wall 21 has reached a certain point in the direction away from the handle, as shown in FIG. 2B, it stops and a catch 33 holding the bin lid 9 closed is released. The bin lid 9 is hinged and a biasing member in the hinge 10 biases the bin lid 9 into an open position. Accordingly, as soon as the catch 33 is released, the bin lid 9 pivots around the hinge 10, and swings open as represented by arrow B. Dirt collected within the bin 20 and the fine dust collection chamber 32 can now be ejected from the dirt separator 2.

[0025] Closing the dirt separator 2 comprises sliding the outer wall 21 back to the original position and pivoting the bin lid 9 into a closed position until the catch 33 engages again to hold the bin lid 9 in the closed position.

[0026] A selection of different attachments are available that can be connected to the vacuum cleaner 1, to allow a user to select the most appropriate attachment for the cleaning task being carried out. FIG. 3A shows how the inlet 6 of the vacuum cleaner 1 comprises an attachment interface. Two attachments in the form of a crevice tool 40 and part of a wand 50 are shown in FIG. 3A which can be attached to the attachment interface at the inlet 6 as indicated by the dotted arrowed lines C. The crevice tool 40 comprises a catch 42 having an engagement portion 44 and a release button 46. The wand 50 comprises a similar catch 52 also having an engagement portion 54 and a release button 56. Alignment ribs 47 and 57 are also provided on the crevice tool 40 and wand 50 respectively. The alignment ribs 47, 57 engage with channels 62 in the attachment interface such

that they slide into the channels 62 as the corresponding attachment is inserted into the attachment interface.

[0027] The attachment interface comprises a formation 60, shown in FIG. 4, that engages with the engagement portion 44, 54 of each catch 42, 52 such that the attachment is locked in place when attached to the attachment interface. The catches 42 and 52 pivot, and are biased into a position in which the engagement portions 44 and 54 will engage with the formation 60 of the attachment interface. To disconnect the attachment, the release button 46, 56 is pressed which causes the catch to pivot, and disengages the engagement portion 44, 54 from the formation 60, such that the attachment can be removed from the attachment interface.

[0028] To prevent the bin 20 from being moved or opened while an attachment is connected to the attachment interface of the inlet 6, the vacuum cleaner comprises an interlock mechanism. The interlock mechanism comprises the protrusion 35 formed as part of the bin lid 9. The protrusion 35 extends radially inwards into the opening of the bin lid 9 through which the inlet 6 protrudes. The protrusion extends radially inwards such that it extends into the attachment interface of the inlet 6, and forms an abutment surface that abuts with any accessory that is connected such that the bin 20 is not able to be moved forward by pushing the bin opening actuator 27, or the bin lid 9 is not able to be opened.

[0029] FIG. 3B shows the vacuum cleaner 1 with the crevice tool 40 attached, and FIG. 3C shows the vacuum cleaner 1 with the wand 50 attached. The protrusion 35 can be seen extending behind the release buttons 46 and 56 of catches 42 and 52, with the side of the release buttons 46, 56 acting as the corresponding abutment surface on the respective attachment. In each case, the protrusion 35 therefore abuts against the side of the release button 46, 56 which acts to prevent any movement of the bin 20, or to prevent the bin lid 9 from opening, while the catch 42, 52 is engaged with the formation 60.

[0030] The wand 50 can be used in conjunction with a cleaner head 70, and when these are connected to the handheld vacuum cleaner 1 as shown in FIG. 5, a stick vacuum cleaner is formed (sometimes referred to as a stick vac). Cleaner heads, such as the cleaner head 70 in FIG. 5, often comprise a motorised brushbar and as such power is required to be transmitted down the wand 50. A power connector 36 is therefore provided at the attachment interface of the inlet 6, as shown in FIGS. 3A and 4. The crevice tool 40 is a simple tool which does not require power, and therefore does not engage with the power connector 36, as can be seen in FIG. 3B. However, the wand 50 comprises a cuff 58 which houses a corresponding wand power connector (not shown) which can engage with the power connector 36 at the inlet 6 such that power from the battery 5 can be provided to the cleaner head to power the brushbar motor.

[0031] The crevice tool 40 and the wand 50 are described as examples of attachments. However, there are a large number of possible attachments, such as an extension hose or a mini-motorised cleaning head, as well as other cleaning tools such as a mattress cleaner tool, a combi-tool etc. Different attachments will have different sizes and requirements, such as can be seen with the crevice tool 40 and the wand 50. However the catch for any attachment will be required to engage with the formation 60 in the attachment interface. As such, it is beneficial to have the interlock mechanism engage with the catch, as this provides a con-

sistent component to abut against no matter what the size, shape or configuration of the attachment.

[0032] Whilst particular embodiments have thus far been described, it will be understood that various modifications may be made without departing from the scope of the invention as defined by the claims.

[0033] For example, the vacuum cleaner **1** described herein is a handheld vacuum cleaner, but it could be any other configuration of vacuum cleaner in which an inlet extends through a bin lid, for example a cylinder vacuum. In addition, the interlock mechanism is described as engaging with the catch on the attachment, and the benefits of this configuration are described above. However, in an alternative embodiment, the interlock mechanism may engage with a different component of the attachment.

1. A cleaning appliance comprising:
 - a dirt separator for separating dirt from an airflow, the dirt separator comprising a bin for collecting dirt separated from the airflow, the bin comprising a bin lid having a closed configuration in which the dirt is retained in the bin, and an open configuration for the removal of dirt from the bin;
 - an inlet that extends through an opening in the bin lid, the inlet comprising an attachment interface; and
 - an interlock configured to prevent the bin lid from being opened when an attachment is connected to the attachment interface.
2. The cleaning appliance of claim **1**, wherein the attachment interface comprises a formation for engaging with a catch provided on an attachment.
3. The cleaning appliance of claim **1**, wherein the interlock comprises a protrusion on the bin lid that extends

radially inwards from the opening, the protrusion forming an abutment surface for abutting with a corresponding abutment surface on an attachment.

4. The cleaning appliance of claim **3**, wherein the protrusion extends into the attachment interface.
5. The cleaning appliance of claim **3**, wherein the cleaning appliance is configured so that, when an attachment is connected to the attachment interface, the abutment surface on the bin lid abuts with a catch on the attachment, the catch acting as the corresponding abutment surface on the attachment.
6. The cleaning appliance of claim **1**, wherein the interlock is configured to prevent the bin lid from being opened when an attachment is connected to the attachment interface and the attachment is one of a wand, an extension hose, and a cleaning tool.
7. The cleaning appliance of claim **1**, wherein the bin lid is hingedly attached to a side wall of the bin and is pivotable between the closed configuration and the open configuration.
8. The cleaning appliance of claim **1**, wherein the bin is movable relative to the air inlet, and the interlock prevents movement of the bin when an attachment is connected to the attachment interface.
9. The cleaning appliance of claim **1**, wherein the cleaning appliance is a handheld vacuum cleaner.
10. The cleaning appliance of claim **9**, further comprising a wand and a cleaner head connected to the attachment interface to form a stick vacuum cleaner.

* * * * *