



INTERNATIONAL APPLICATION PUBLISHED UNDER THE PATENT COOPERATION TREATY (PCT)

<p>(51) International Patent Classification ⁶ : F26B 3/34, 9/00, 13/00, 13/06</p>	<p>A1</p>	<p>(11) International Publication Number: WO 98/34079 (43) International Publication Date: 6 August 1998 (06.08.98)</p>
<p>(21) International Application Number: PCT/US98/01120 (22) International Filing Date: 5 January 1998 (05.01.98) (30) Priority Data: 08/796,009 5 February 1997 (05.02.97) US (71) Applicant: MEGTEC SYSTEMS, INC. [US/US]; 830 Prosper Road, De Pere, WI 54115-0030 (US). (72) Inventors: ROGNE, Allan, W.; 2531 44th Street, Two Rivers, WI 55241 (US). QUASS, Jeffrey, D.; 2254 Boardwalk Avenue, Green Bay, WI 54311 (US). TESAR, Michael, G.; 3505 Lime Kiln Road, Green Bay, WI 54311 (US). (74) Agent: BITTMAN, Mitchell, D.; Sequa Corporation, Three University Plaza, Hackensack, NJ 07601 (US).</p>		<p>(81) Designated States: AL, AM, AT, AU, AZ, BA, BB, BG, BR, BY, CA, CH, CN, CU, CZ, DE, DK, EE, ES, FI, GB, GE, GH, GM, GW, HU, ID, IL, IS, JP, KE, KG, KP, KR, KZ, LC, LK, LR, LS, LT, LU, LV, MD, MG, MK, MN, MW, MX, NO, NZ, PL, PT, RO, RU, SD, SE, SG, SI, SK, SL, TJ, TM, TR, TT, UA, UG, UZ, VN, YU, ZW, ARIPO patent (GH, GM, KE, LS, MW, SD, SZ, UG, ZW), Eurasian patent (AM, AZ, BY, KG, KZ, MD, RU, TJ, TM), European patent (AT, BE, CH, DE, DK, ES, FI, FR, GB, GR, IE, IT, LU, MC, NL, PT, SE), OAPI patent (BF, BJ, CF, CG, CI, CM, GA, GN, ML, MR, NE, SN, TD, TG).</p> <p>Published <i>With international search report.</i></p>

(54) Title: HIGH SPEED INFRARED/CONVECTION DRYER

(57) Abstract

A combination infrared/convection dryer or oven (10) for drying travelling webs (W). A shutter assembly (8) is provided between the infrared radiation source (16) and the moving web in order to selectively expose the web to infrared radiation. Drying efficiency is optimized by adding heated impinged air at high velocity on the machine direction ends and between the infrared elements. The air being discharged on the web is heated as it is pulled across the elements to a centralized return air duct (42). The return air is pulled into the inlet of a close coupled supply fan (28) which then discharges the air to the nozzles. A portion of the air is also exhausted at atmosphere to maintain the oven enclosure in a negative pressure state, thus drawing fresh make-up air into the oven housing through the web inlet (12) and outlet (13) slots. Flotation nozzles (151, 152) can be used where contactless support of the running web is desired. Enhanced drying of the web and/or a coating on the web at high speed is achieved without a concomitant increase in dryer length.

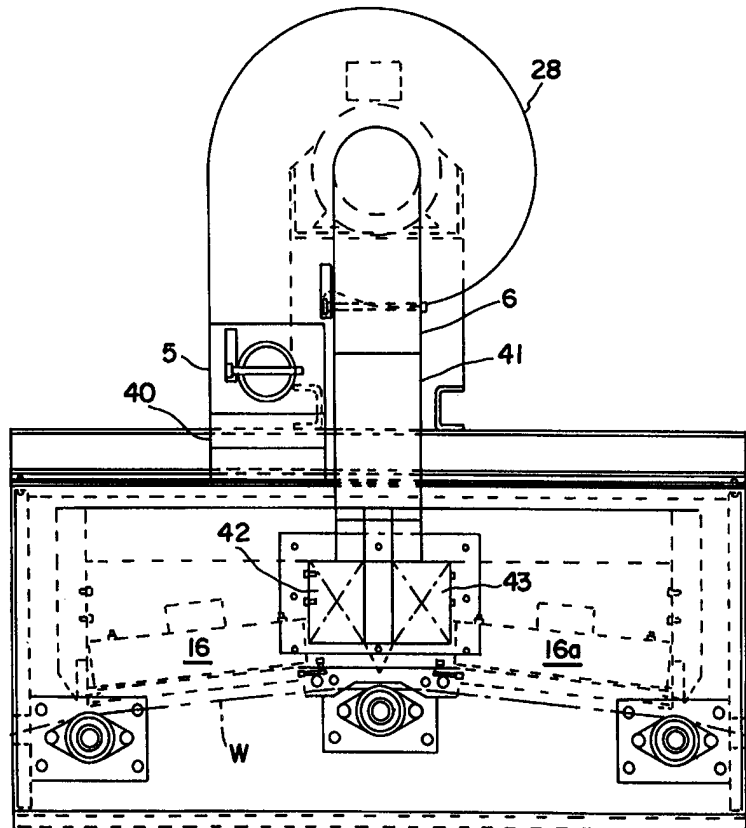

FOR THE PURPOSES OF INFORMATION ONLY

Codes used to identify States party to the PCT on the front pages of pamphlets publishing international applications under the PCT.

AL	Albania	ES	Spain	LS	Lesotho	SI	Slovenia
AM	Armenia	FI	Finland	LT	Lithuania	SK	Slovakia
AT	Austria	FR	France	LU	Luxembourg	SN	Senegal
AU	Australia	GA	Gabon	LV	Latvia	SZ	Swaziland
AZ	Azerbaijan	GB	United Kingdom	MC	Monaco	TD	Chad
BA	Bosnia and Herzegovina	GE	Georgia	MD	Republic of Moldova	TG	Togo
BB	Barbados	GH	Ghana	MG	Madagascar	TJ	Tajikistan
BE	Belgium	GN	Guinea	MK	The former Yugoslav Republic of Macedonia	TM	Turkmenistan
BF	Burkina Faso	GR	Greece			TR	Turkey
BG	Bulgaria	HU	Hungary	ML	Mali	TT	Trinidad and Tobago
BJ	Benin	IE	Ireland	MN	Mongolia	UA	Ukraine
BR	Brazil	IL	Israel	MR	Mauritania	UG	Uganda
BY	Belarus	IS	Iceland	MW	Malawi	US	United States of America
CA	Canada	IT	Italy	MX	Mexico	UZ	Uzbekistan
CF	Central African Republic	JP	Japan	NE	Niger	VN	Viet Nam
CG	Congo	KE	Kenya	NL	Netherlands	YU	Yugoslavia
CH	Switzerland	KG	Kyrgyzstan	NO	Norway	ZW	Zimbabwe
CI	Côte d'Ivoire	KP	Democratic People's Republic of Korea	NZ	New Zealand		
CM	Cameroon			PL	Poland		
CN	China	KR	Republic of Korea	PT	Portugal		
CU	Cuba	KZ	Kazakstan	RO	Romania		
CZ	Czech Republic	LC	Saint Lucia	RU	Russian Federation		
DE	Germany	LI	Liechtenstein	SD	Sudan		
DK	Denmark	LK	Sri Lanka	SE	Sweden		
EE	Estonia	LR	Liberia	SG	Singapore		

HIGH SPEED INFRARED/CONVECTION DRYERBACKGROUND OF THE INVENTION

The present invention relates to web drying apparatus. In drying a moving web of material, such as paper, film or other sheet or planar material, it is often desirable that the web be dried quickly, and that the length of the dryer be limited in view of space and cost constraints. Various attempts have been made in the prior art for decreasing the length and/or increasing the efficiency and line speed of web dryers. To that end, infrared radiation has been used either alone or in combination with air to dry the web. For example, U.S. Patent No. 4,936,025 discloses a method for drying a moving web by passing the web free of contact through various drying gaps. Thus, the web is passed through an infrared treatment gap in which infrared radiation is applied to the web from an infrared unit, and then is passed into an air-drying gap within which the web is dried by gas blowings from an airborne web dryer unit which simultaneously supports the web free of contact. Further, U.S. Patent No. 4,756,091 discloses a hybrid gas-heated air and infrared radiation drying oven in which strips of infrared heaters are arranged with heated air inflow nozzles alongside thereof. U.S. Patent No. 5,261,166 discloses a combination infrared and air flotation dryer wherein a plurality of air bars are mounted above and below the web for contactless convection drying of the web, and a plurality of infrared gas fired burners are mounted between air bars.

In many conventional infrared dryers, however, much of the heat supplied by the infrared energy source is lost to

surroundings by transmission, reflection and radiation. In addition, the infrared elements must be continually turned on and off to avoid burning of the web. This reduces efficiency and can reduce infrared element life.

It is therefore an object of the present invention to provide a more efficient combination infrared/convection oven or dryer for drying moving webs.

It is a further object of the present invention to provide optimal control of an infrared/convection oven.

It is a still further object of the present invention to provide infrared and convection drying while floatingly supporting the moving web.

It is another object of the present invention to eliminate the need to continually turn the infrared elements on and off.

SUMMARY OF THE INVENTION

The problems of the prior art have been overcome by the present invention, which provides a combination infrared/convection dryer or oven for travelling webs. A shutter assembly is provided between the infrared radiation source and the moving web in order to selectively expose the web to infrared radiation. Drying efficiency is optimized by adding heated impinged air at high velocity on the machine direction ends and between the infrared elements. The air being discharged on the web is heated as it is pulled across the elements to a centralized return air duct. The return air is pulled into the inlet of a close coupled supply fan which then discharges the air to the nozzles. A portion of the air is also exhausted to

atmosphere to maintain the oven enclosure in a negative pressure state, thus drawing fresh make-up air into the oven housing through the web inlet and outlet slots. Enhanced drying of the web and/or a coating on the web at high speed is achieved without a concomitant increase in dryer length.

In one embodiment of the invention, air bars are used to floatingly support the moving web to avoid contact of the web with dryer elements.

BRIEF DESCRIPTION OF THE DRAWINGS

Figure 1 is a front view of the infrared/convention oven in accordance with the present invention;

Figure 2 is a top view of the shutter assembly for use in the dryer of the present invention;

Figure 3 is a front view of the shutter assembly taken along line B-B of Figure 2;

Figure 4 is a side view of the shutter assembly, taken along line A-A of Figure 2;

Figure 5 is a detailed view showing the connection of a shutter to the control mechanism in accordance with the present invention;

Figure 6 is a front view of the oven with a close coupled fan assembly; and

Figure 7 is a schematic cross-sectional view of an infrared/convention floatation oven in accordance with an alternative embodiment of the present invention.

DETAILED DESCRIPTION OF THE INVENTION

Turning first to Figure 1, there is shown generally at 10 a dryer or oven in accordance with the present invention. The oven 10 is defined by a housing 11, preferably insulated, having a web inlet opening 12 to accommodate entry of a web W into the housing and a web outlet opening 13 spaced from the inlet 12 to accommodate exit of the web W from the housing, as shown. The housing 11 can be constructed of any suitable preferably reflective material, such as aluminum or stainless steel. A plurality of spaced idler rollers 14a-14n are provided to guide and support the web W as it travels through the oven 10 from the inlet 12 to the outlet 13. It is preferred that the rollers 14 be positioned at least below each source of impingement air 15a, 15b and 15c as shown, since at the points of impingement, the web W needs the most support to avoid web flutter, especially during low tension instances. A pair of infrared radiation elements 16, 16a are secured in the housing 11 to supplement the drying of the web.

Impingement air is preferably provided upstream and downstream of each infrared radiation source 16, 16a, which in the embodiment shown, is near the oven inlet 12, near the oven outlet 13, and in a central location in the oven. Air bars 15a, 15b and 15c are provided for this purpose, and are in communication with an air supply source, such as a fan, through suitable ductwork. The particular configurations of the air bars 15a and 15c are similar, and are designed to form air knives that provide mass transfer to the web and cooling air to the shutter assembly. The configuration of the central air bar 15b is designed to provide mass transfer to promote drying.

Positioned between air impingement sources 15a and 15b is elemental infrared radiation source 16. Toward the web inlet end the infrared radiation source 16 is mounted to the air impingement source 15a with L-shaped sheet 7, and is preferably angled upwardly towards the center of the oven as shown. This upward angle creates enough overwrap on the non-drive idler roller to create a driving force for the roller so that the web W proceeds properly through the oven. Similarly, positioned between air impingement sources 15b and 15c is a second infrared radiation source 16a, similarly mounted to the air impingement source 15c with L-shaped sheet 7a, and also angled upwardly towards the center of the oven 10 as shown.

Shutter assemblies 8 and 9 are positioned below infrared elements 16a and 16, respectively, to allow for control of the radiation permitted to reach the web W without the necessity of turning off the infrared radiation source(s). Referring to Figure 2, each shutter assembly includes a plurality of aligned blades 20, each blade 20 slightly overlapping its adjacent blade when in the closed position, as best seen in Figure 3. The number of blades 20 in each shutter assembly can vary, and depends on the particular dimensions of the infrared heating element being used. Although the dimensions of each blade are not critical, it has been found that blades 1 inch wide are suitable, and that such blades can be placed 0.94 inches center-to-center to create the necessary overlap. Preferably the damper blades 20 are designed with a reflecting surface to reflect the infrared light back towards the infrared elements and direct it away from the web.

Referring now to Figure 5, the blades 20 are attached to the shutter assembly using a pin arrangement as shown. Thus, each end of each blade 20 is pivotally affixed to a clamp 32 on the end of pin 30. The end of pin 30 opposite clamp 32 is affixed to damper push link arm 33. Each push link arm 33 for each damper blade 20 is then connected via a connecting link 34 (Figure 4), which allows all of the dampers to be pivoted upon actuation of an air cylinder 40 (located externally of the oven) which connects to a cylinder clevis 37 and then to the connecting link 34 via the damper link pivot 35.

Preferably the opening and closing of the shutters is based on line speed. At a predetermined line speed set point (which can be signaled by any suitable means, such as a magnetic pick-up connected to the coating line drive shaft), the shutters open and allow exposure of the web to the infrared radiation. In the event the line speed drops below the set point, the shutters close and prevent burning of the web.

As shown in Figure 6, a supply/exhaust fan 28 is in communication with the oven, and in particular, the air bars 15a, 15b and 15c, via suitable ductwork 40, 41. The fan 28 is sized to accommodate excess air that is exhausted in order to maintain the oven enclosure in a negative pressure state. This negative pressure causes infiltration air to enter into the oven 10 through the web inlet and outlet slots 12 and 13. Dampers 5 and 6 are provided in the ductwork to regulate the flow of air to and from the fan 28. Return air is pulled from the return ducts 42, 43 in the oven by the supply/exhaust fan 28. Since the return ducts are centrally located in the oven 10, the return air is

directed over the entire face of the infrared heating element, thereby heating the recirculated supply air to improve efficiency.

Figure 7 shows an alternative embodiment of the present invention that employs flotation nozzles in place of the idler rollers in order to provide non-contact web support. Suitable flotation air bars include HI-FLOAT[®] air bars commercially available from Grace Tec Systems. In the embodiment shown, air knives 15a and 15c are positioned at the web entry and exit ends of the dryer in a manner similar to that in the previous embodiment, and provide mass transfer to the web and cooling air to the shutter assemblies as before. An air flotation nozzle 150 is preferably centrally located between air knives 15a and 15b. Similar air flotation nozzles 151 and 152 are positioned below the web between air knives 15a' and 15c', and are offset from air flotation nozzle 150. Air issuing from the air flotation nozzles supports and floatingly dries the running web. Elemental infrared radiation sources 16 and 16a, together with shutter assemblies (not shown) are positioned between each air knife and the flotation nozzle 150 above the web, analogous to the previous embodiment. Optionally, an infrared radiation source 160 and corresponding shutter assembly (not shown) can be located below the web and between flotation nozzles 151 and 152 to enhance drying efficiency.

Those skilled in the art will appreciate that the infrared radiation sources can be used above the web, below the web, or both, depending upon the drying capacity desired. Similarly, the particular location of the flotation nozzles will depend upon

drying capacity, provided adequate web support is achieved.

An infrared pyrometer (not shown) is incorporated into the control scheme to maintain exit web temperature. Shutter open/close timing is based on the percent press speed. The shutter open/close control is also interlocked to a web break detector.

In operation, the supply/exhaust fan 28 is turned on, and a preheat cycle is begun by activating the shutter assembly to the closed position. The infrared element is turned on and a desired temperature set point is achieved, such as 1400°F. Once the set point is reached (which can be signaled by any suitable means, such as a light on a control panel), temperature is subsequently controlled via a thermocouple and SCR controller.

At the set point temperature, the oven is ready to dry. The shutter assembly is opened and closed via a line speed control set point, such as 70 feet per minute. Upon reaching the line speed set point, the shutters will open, thereby emitting the infrared energy to the web W media. Control of the element temperature will now shift to the web temperature via the web temperature infrared pyrometer and the SCR controller.

As the line speed is brought down to an intermittent stop, the shutter assembly will again be closed, once it decelerates past the line speed control set point. The infrared element temperature control will take over, maintaining the ready temperature set point. The same sequence occurs in the event of a web break.

Preferably a safety shutdown is incorporated that is based upon the infrared element temperature. For example, in the event

the element temperature reaches 1800°F, a high temperature limit switch will actuate and shut off the element.

What is claimed is:

1. An infrared/convection dryer for a moving web, comprising:

a dryer enclosure having a web inlet slot and a web outlet slot spaced from said web inlet slot;

impingement means in said enclosure for causing gas to impinge upon said web;

a fan in communication with said impingement means for supplying said gas to said impingement means;

infrared heating means in said enclosure for irradiating infrared light and heating said web; and

shutter means in said enclosure, said shutter means being moveable between a first open position allowing said irradiated infrared light to impinge upon said web and a second closed position preventing said irradiated infrared light from impinging upon said web.

2. The infrared/convection dryer of claim 1, further comprising a return duct in said dryer enclosure for recirculating heated air to said fan and back into said enclosure.

3. The infrared/convection dryer of claim 1, wherein said impingement means comprises a plurality of air nozzles.

4. The infrared/convection dryer of claim 3, wherein said web is supported in said oven by a plurality of rollers, each positioned below an air nozzle.

5. The infrared/convection dryer of claim 1, wherein said impingement means comprises a plurality of flotation nozzles.

6. The infrared/convection dryer of claim 1, wherein the

opening and closing of said shutter means is responsive to the speed of said moving web.

7. An infrared/convection dryer for drying a running web, comprising:

an dryer housing having a web inlet slot and a web outlet slot spaced from said web inlet slot;

impingement means in said housing for causing gas to impinge upon said web;

a fan in communication with said impingement means for supplying said gas to said impingement means;

infrared heating means in said housing for irradiating infrared light and heating said web;

means for measuring the speed of said running web;

shutter means in said housing responsive to said measured speed of said running web for selectively directing said infrared light away from said running web when said measured speed falls below a predetermined value.

8. The infrared/convection dryer of claim 7, further comprising a return duct in said dryer housing for recirculating heated air to said fan and back into said housing.

9. The infrared/convection dryer of claim 7, wherein said impingement means comprises a plurality of air nozzles.

10. The infrared/convection dryer of claim 9, wherein said web is supported in said dryer by a plurality of rollers, each positioned below an air nozzle.

11. The infrared/convection dryer of claim 7, wherein said impingement means comprises a plurality of flotation nozzles.

12. A method of drying a running web, comprising:

providing a dryer enclosure having a web inlet slot and a web outlet slot spaced from said web inlet slot;

causing said running web to travel through said dryer enclosure;

measuring the speed of said running web;

impinging gas onto said running web in said enclosure;

selectively irradiating infrared light onto said running web in said enclosure; and

directing said infrared light away from said running web when said measured speed of said running web falls below a predetermined value.

13. The method of claim 12, wherein said infrared light is directed away from said running web by reflection.

14. The method of claim 12, wherein said infrared light is directed away from said running web by closing a shutter assembly positioned in said enclosure between said infrared light and said web.

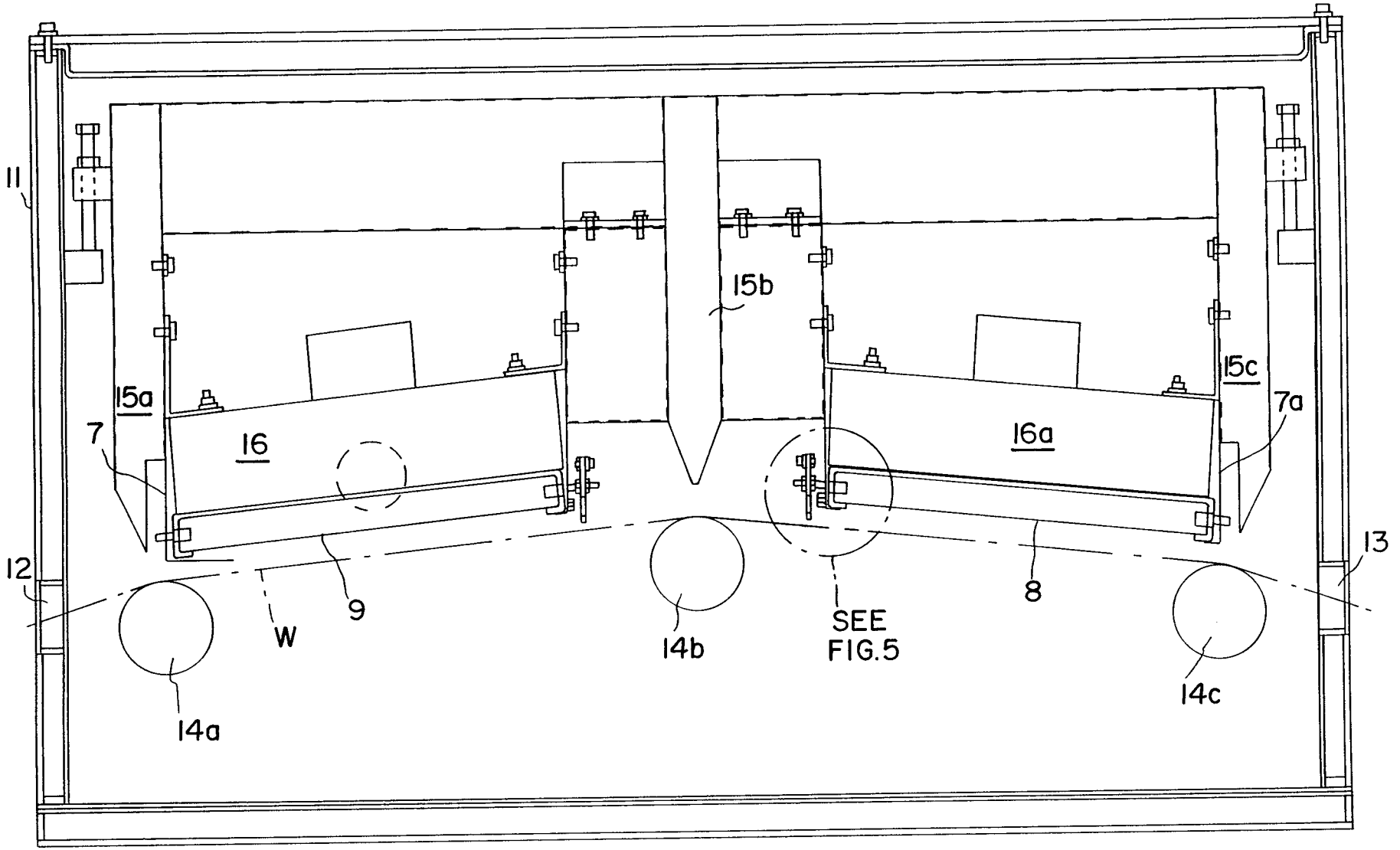

FIG. 1

SUBSTITUTE SHEET (RULE 26)

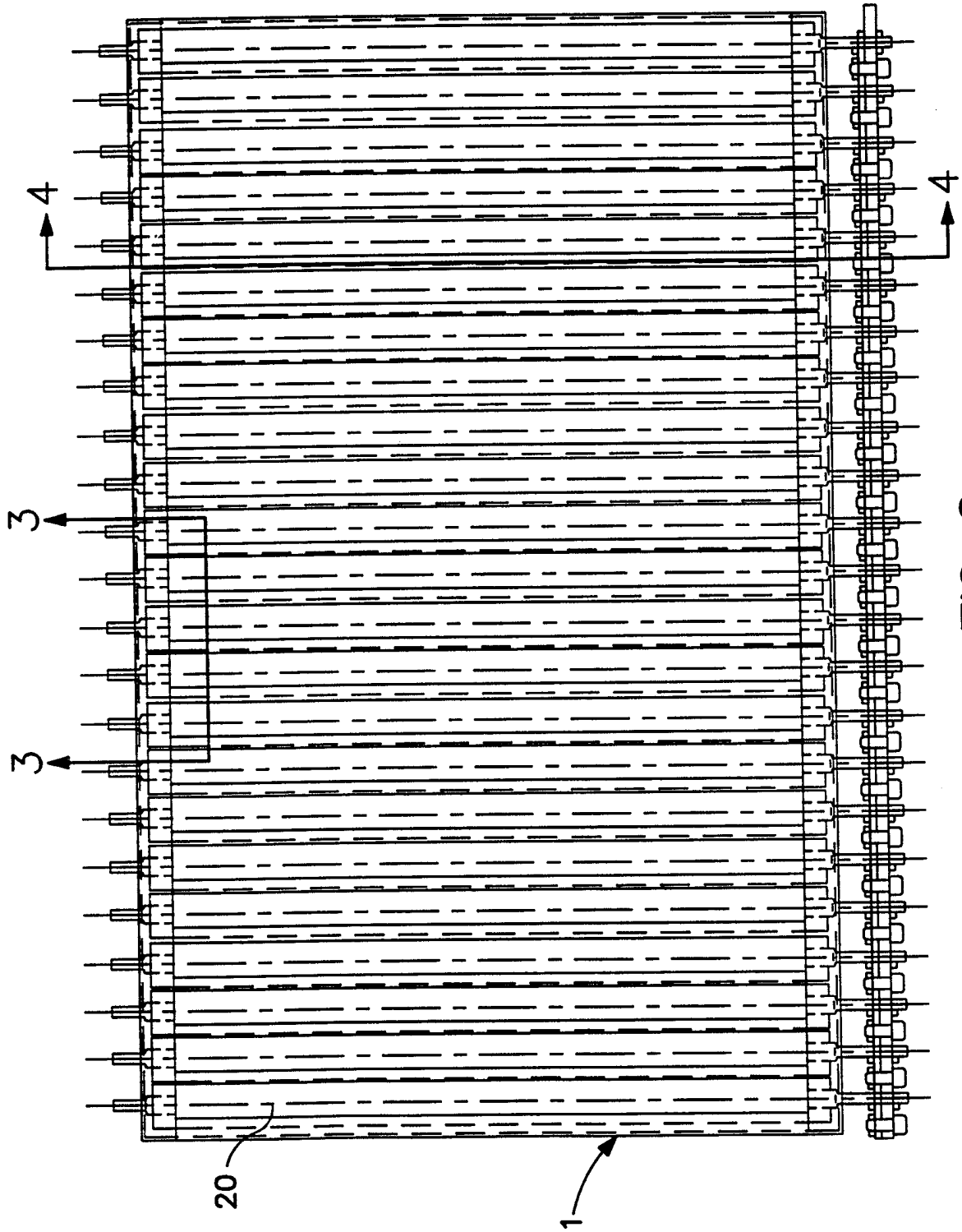

FIG. 2

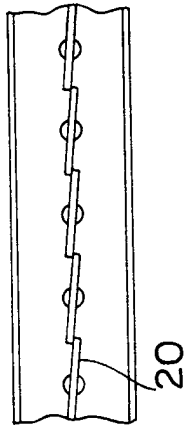

FIG. 3

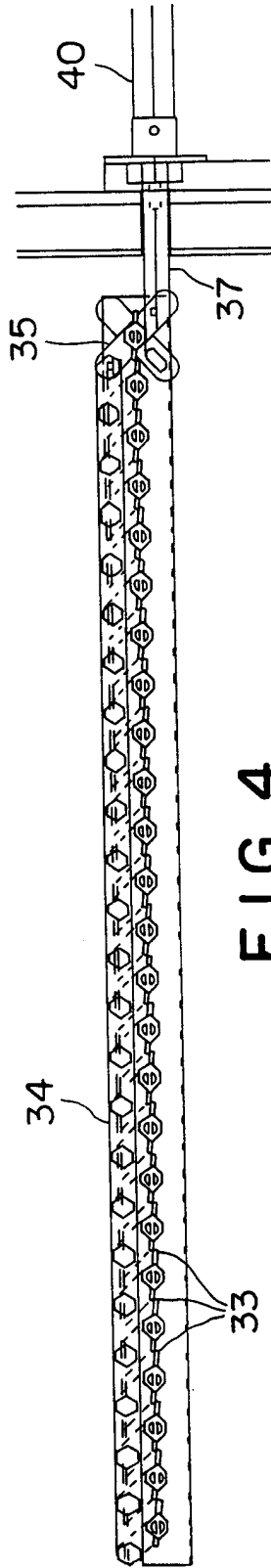

FIG. 4

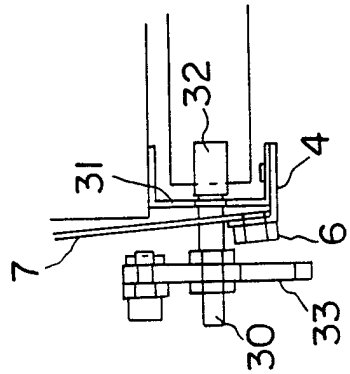

FIG. 5

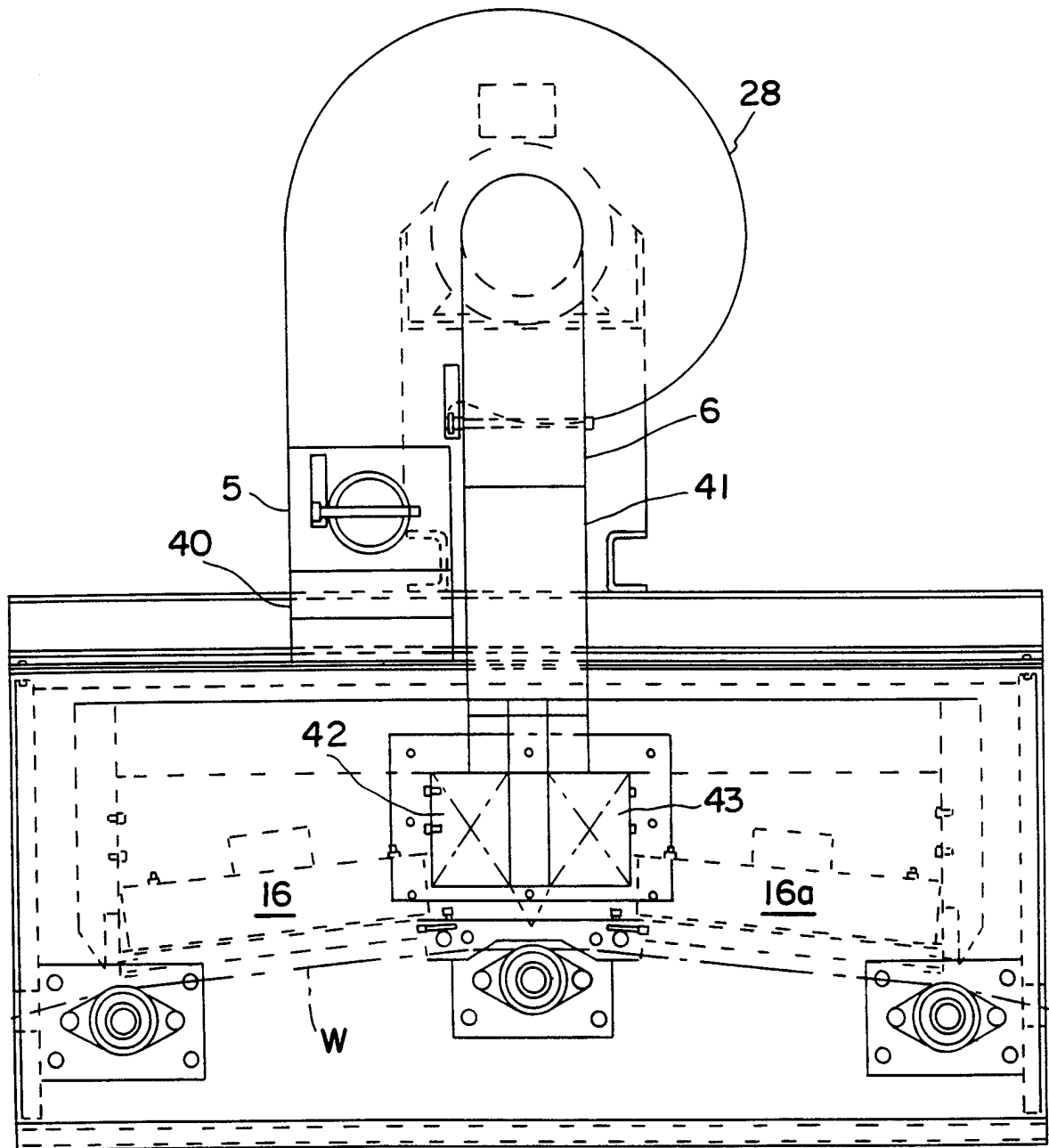

FIG. 6

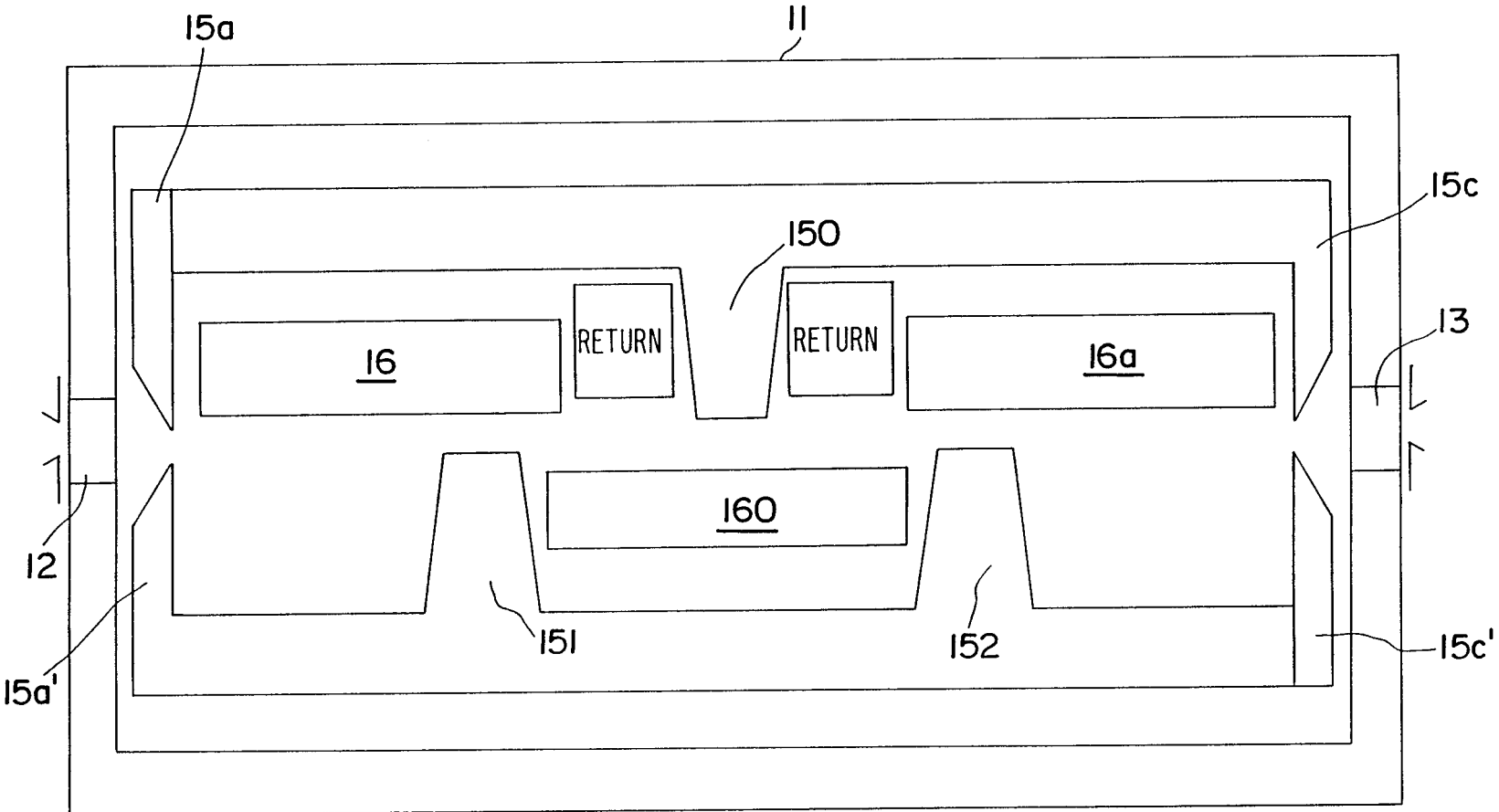

FIG. 7

SUBSTITUTE SHEET (RULE 26)

INTERNATIONAL SEARCH REPORT

International application No.
PCT/US98/01120

A. CLASSIFICATION OF SUBJECT MATTER		
IPC(6) : F26B 3/34, 9/00, 13/00, 13/06		
US CL : 34/267, 268, 269, 619, 629, 633		
According to International Patent Classification (IPC) or to both national classification and IPC		
B. FIELDS SEARCHED		
Minimum documentation searched (classification system followed by classification symbols)		
U.S. : 34/267, 268, 269, 619, 629, 633		
Documentation searched other than minimum documentation to the extent that such documents are included in the fields searched		
Electronic data base consulted during the international search (name of data base and, where practicable, search terms used)		
APS, MAYA		
C. DOCUMENTS CONSIDERED TO BE RELEVANT		
Category*	Citation of document, with indication, where appropriate, of the relevant passages	Relevant to claim No.
X	US 3,643,342 A (TYSON et al) 22 February 1972, col. 2, lines 1-70.	1-3, 6-10
Y	US 5,261,166 A (SEELEY et al) 16 November 1993, col. 4, lines 32-35.	5,11
<input type="checkbox"/> Further documents are listed in the continuation of Box C. <input type="checkbox"/> See patent family annex.		
* Special categories of cited documents:		
A	document defining the general state of the art which is not considered to be of particular relevance	*T* later document published after the international filing date or priority date and not in conflict with the application but cited to understand the principle or theory underlying the invention
B	earlier document published on or after the international filing date	*X* document of particular relevance; the claimed invention cannot be considered novel or cannot be considered to involve an inventive step when the document is taken alone
L	document which may throw doubts on priority claim(s) or which is cited to establish the publication date of another citation or other special reason (as specified)	*Y* document of particular relevance; the claimed invention cannot be considered to involve an inventive step when the document is combined with one or more other such documents, such combination being obvious to a person skilled in the art
O	document referring to an oral disclosure, use, exhibition or other means	*G* document member of the same patent family
P	document published prior to the international filing date but later than the priority date claimed	
Date of the actual completion of the international search		Date of mailing of the international search report
27 FEBRUARY 1998		24 APR 1998
Name and mailing address of the ISA/US Commissioner of Patents and Trademarks Box PCT Washington, D.C. 20231 Facsimile No. (703) 305-3230		Authorized officer <i>J. Hurley for</i> STEVE GRAVINI Telephone No. (703) 308-7570