



US00D957532S

(12) **United States Design Patent**
Wang et al.

(10) **Patent No.:** **US D957,532 S**

(45) **Date of Patent:** **** Jul. 12, 2022**

(54) **ELECTRIC SCOOTER**

(71) Applicant: **Freeman IT Limited**, Shenzhen (CN)

(72) Inventors: **Jing Wang**, Shenzhen (CN); **Haibo Liu**, Shenzhen (CN)

(73) Assignee: **Freeman IT Limited**, Shenzhen (CN)

(**) Term: **15 Years**

(21) Appl. No.: **29/729,718**

(22) Filed: **Mar. 30, 2020**

(30) **Foreign Application Priority Data**

Feb. 11, 2020 (CN) 202030048907.1

(51) **LOC (13) Cl.** **21-01**

(52) **U.S. Cl.**
USPC **D21/423**

(58) **Field of Classification Search**

USPC D21/419, 421, 423, 432, 435, 760, 763,
D21/771; D12/1, 110

CPC B62K 3/002; B62K 9/00; B62K 2202/00;
B62K 15/00; B62K 2015/001; B62K
2015/003; B60Y 2200/126

See application file for complete search history.

(56) **References Cited**

U.S. PATENT DOCUMENTS

D858,647	S	*	9/2019	Liu	D21/423
D900,237	S	*	10/2020	Lee	D21/423
D905,794	S	*	12/2020	Liu	D21/423
D910,121	S	*	2/2021	Liu	D21/423
D912,159	S	*	3/2021	Lee	D21/423
D912,736	S	*	3/2021	Lee	D21/423

(Continued)

Primary Examiner — Cynthia M. Chin

(74) *Attorney, Agent, or Firm* — Westbridge IP LLC

(57) **CLAIM**

The ornamental design for an electric scooter, as shown and described.

DESCRIPTION

FIG. 1 is a front perspective view of a first embodiment of an electric scooter showing our new design;

FIG. 2 is a rear perspective view thereof;

FIG. 3 is a front elevational view thereof;

FIG. 4 is a rear elevational view thereof;

FIG. 5 is a left side elevational view thereof;

FIG. 6 is a right side elevational view thereof;

FIG. 7 is a top plan view thereof;

FIG. 8 is a bottom plan view thereof;

FIG. 9 is an enlarged partial view of the handle bar stem taken from FIG. 1;

FIG. 10 is a front perspective view of a second embodiment of the electric scooter;

FIG. 11 is a rear perspective view of the electric scooter of FIG. 10;

FIG. 12 is a front elevational view of the electric scooter of FIG. 10;

FIG. 13 is a rear elevational view of the electric scooter of FIG. 10;

FIG. 14 is a left side elevational view of the electric scooter of FIG. 10;

FIG. 15 is a right side elevational view of the electric scooter of FIG. 10;

FIG. 16 is a top plan view of the electric scooter of FIG. 10;

FIG. 17 is a bottom plan view of the electric scooter of FIG. 10; and,
FIG. 18 is an enlarged partial view of the handle bar stem taken from FIG. 10.

The dash-dash broken lines in the drawings illustrate portions of the electric scooter which form no part of the claimed design.

The dash-dot broken lines represent the boundaries of the enlarged partial views of FIGS. 9 and 18 and form no part of the claimed design.

1 Claim, 18 Drawing Sheets

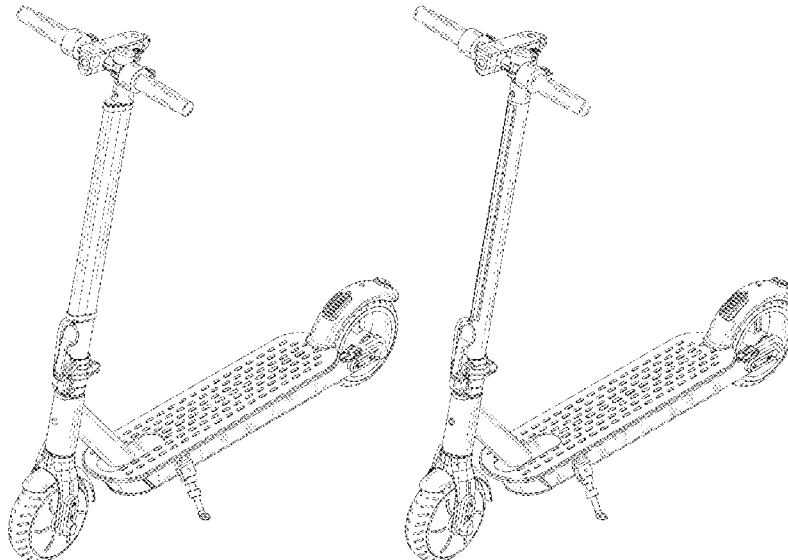

(56)

References Cited

U.S. PATENT DOCUMENTS

D917,625	S *	4/2021	Lee	D21/423
D923,714	S *	6/2021	Shen	D21/423
D923,715	S *	6/2021	Wang	D21/423
2020/0283086	A1 *	9/2020	Ulmén	B62K 3/002

* cited by examiner

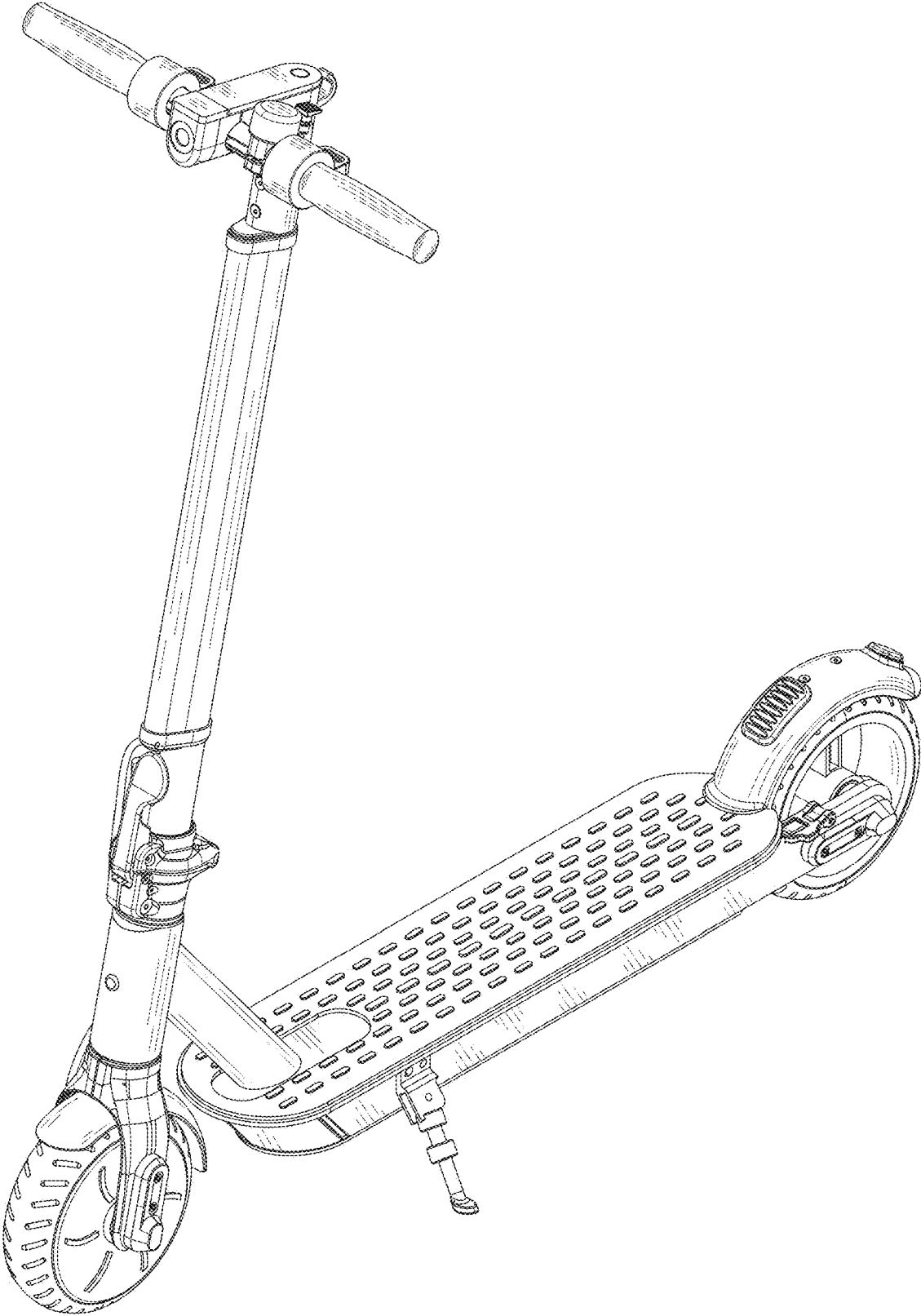

FIG. 1

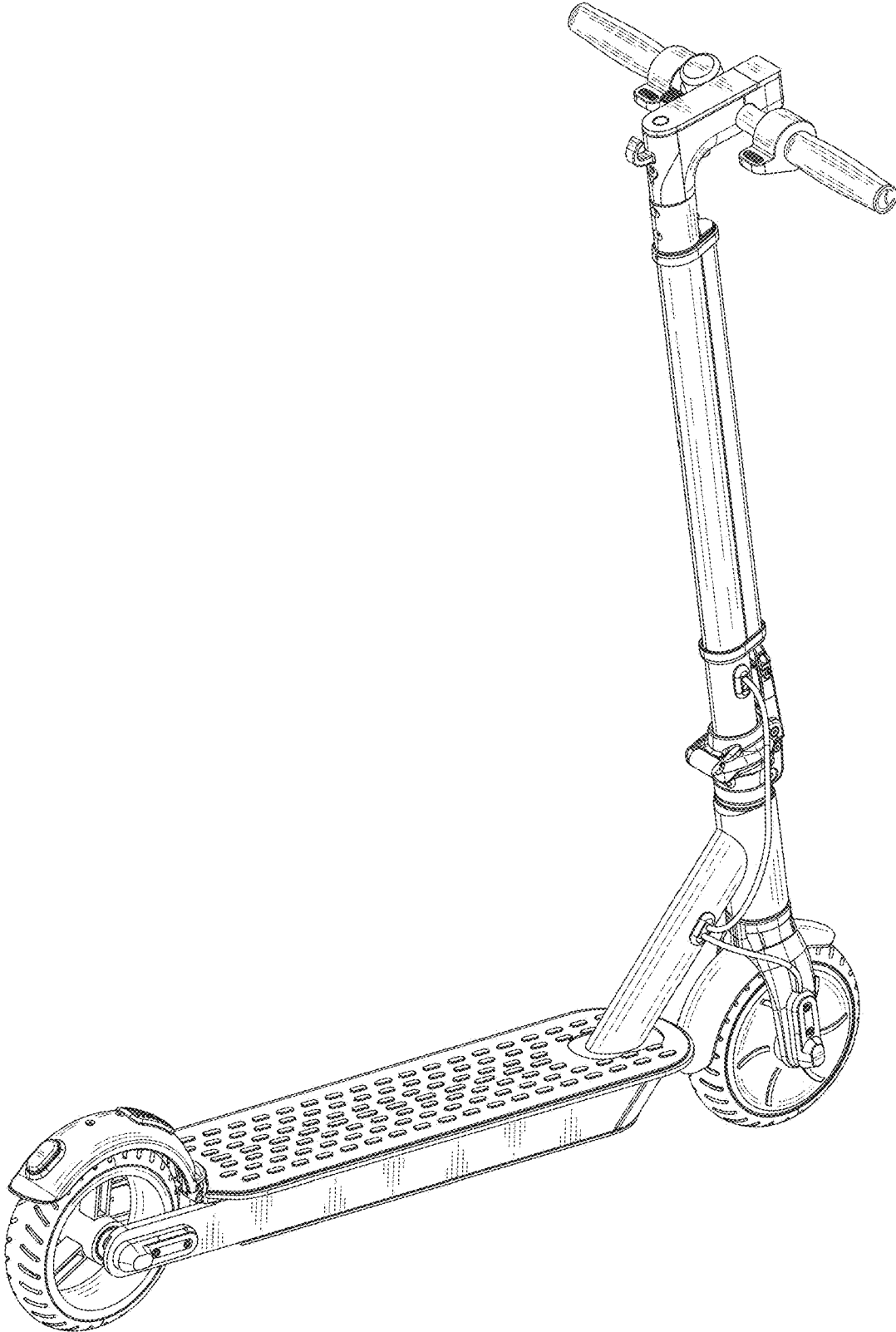

FIG. 2

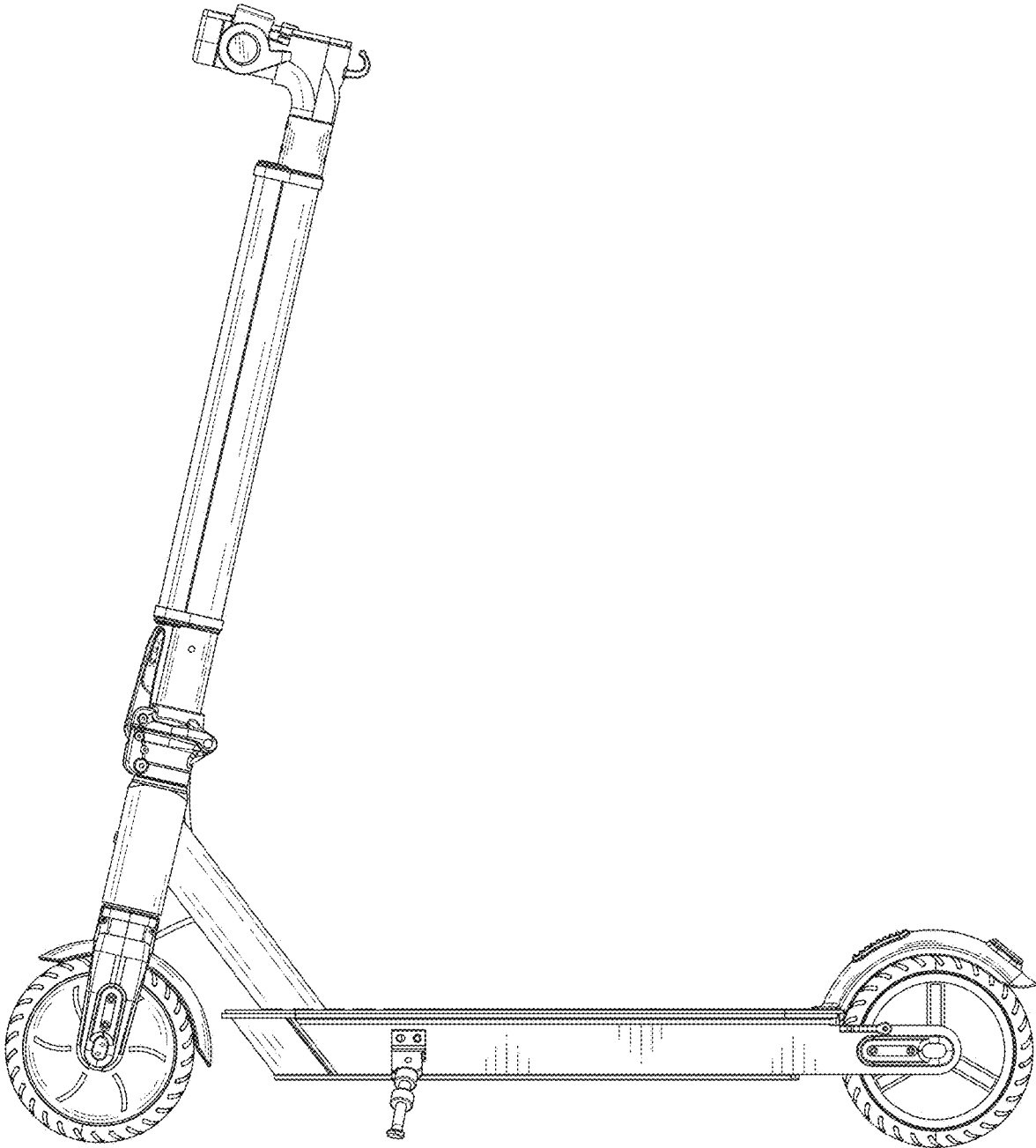

FIG. 3

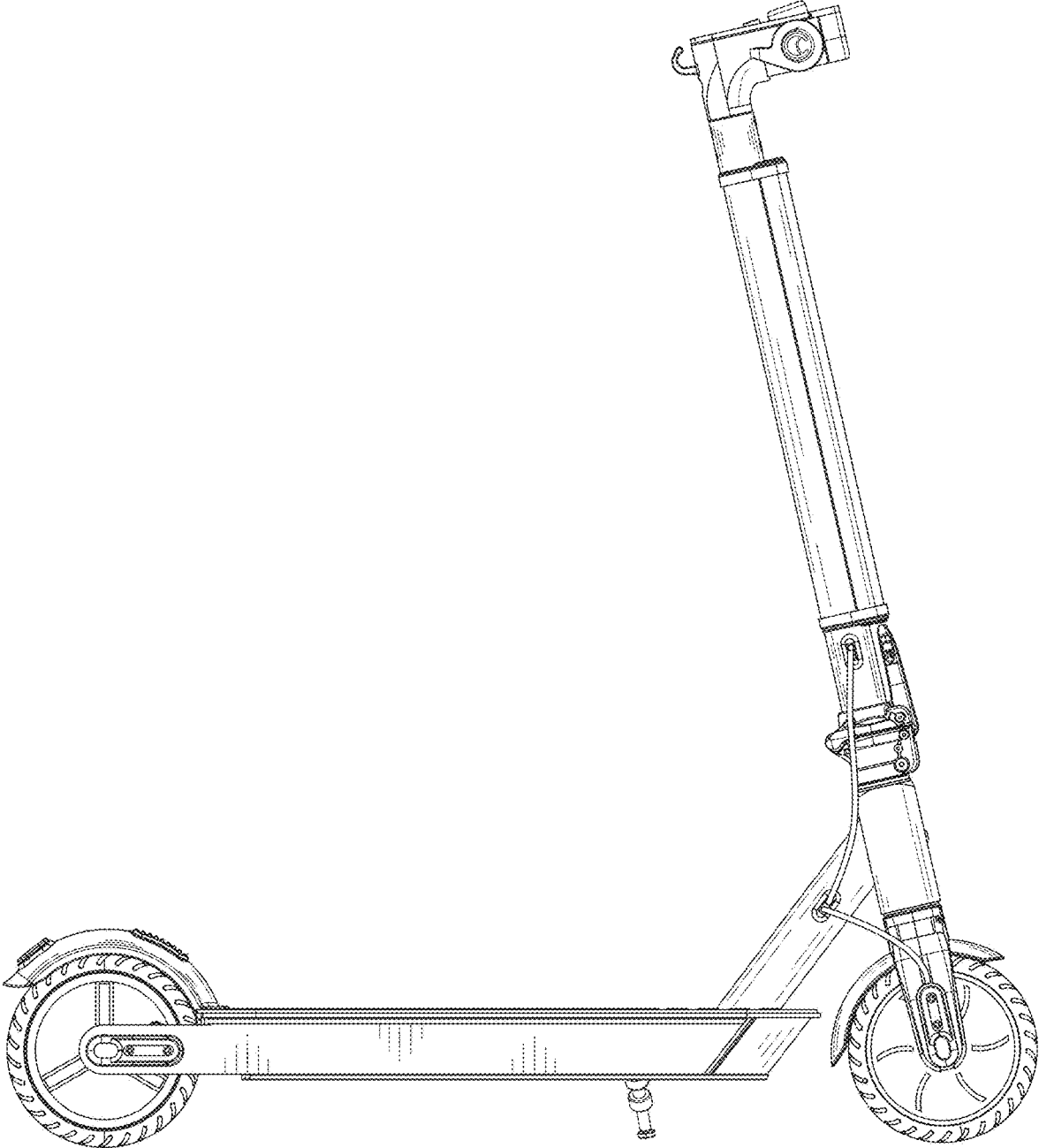

FIG. 4

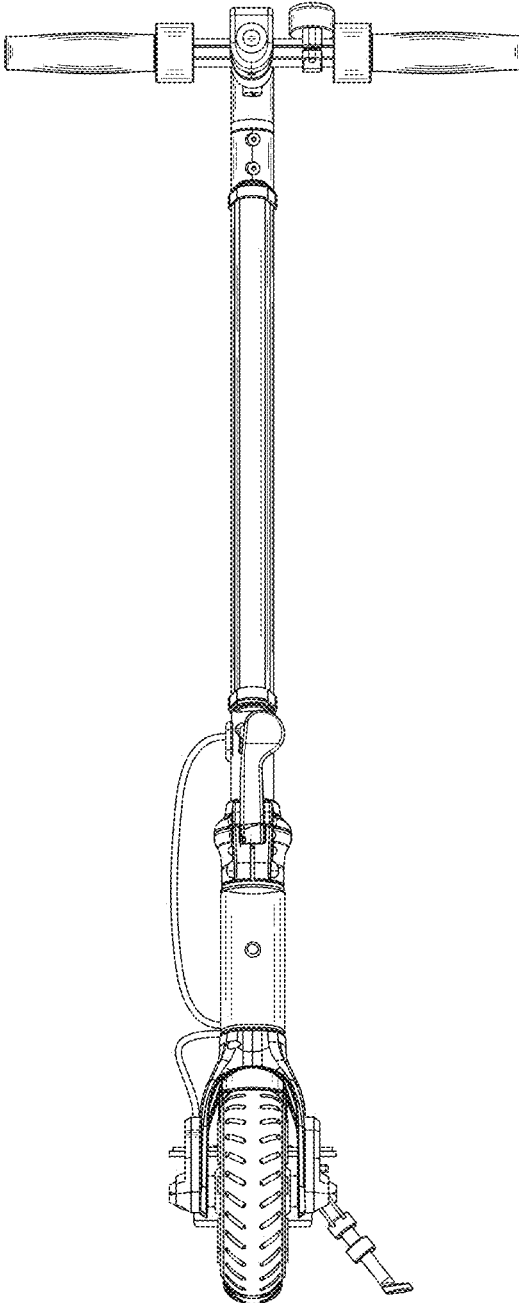

FIG. 5

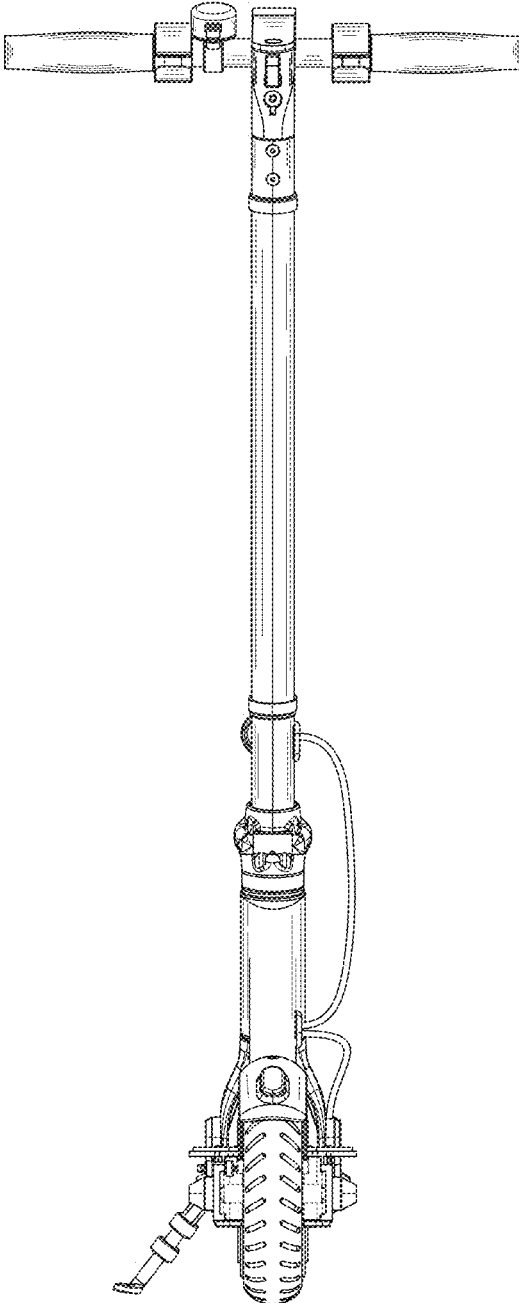

FIG. 6

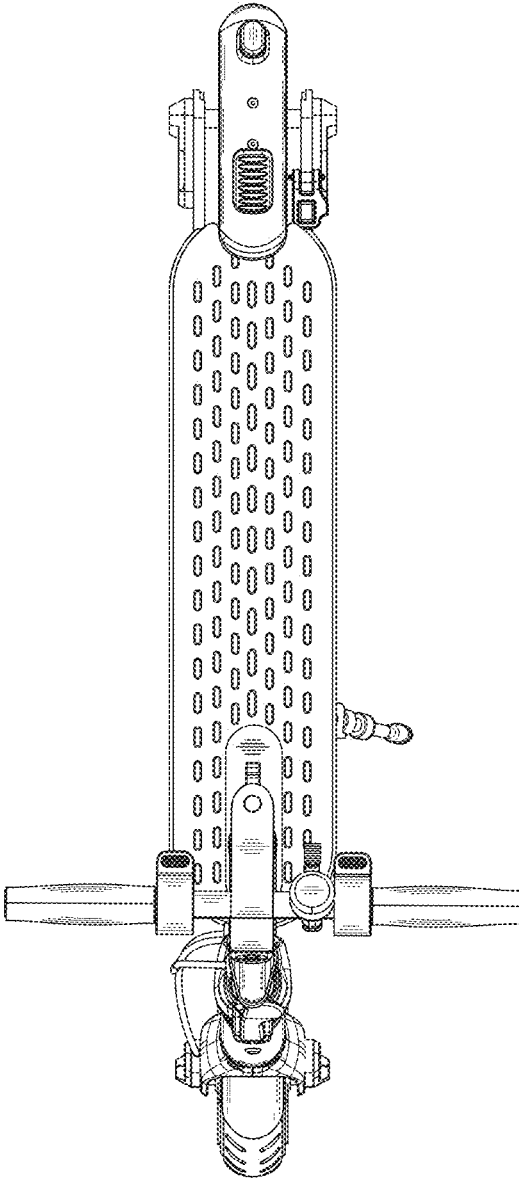

FIG. 7

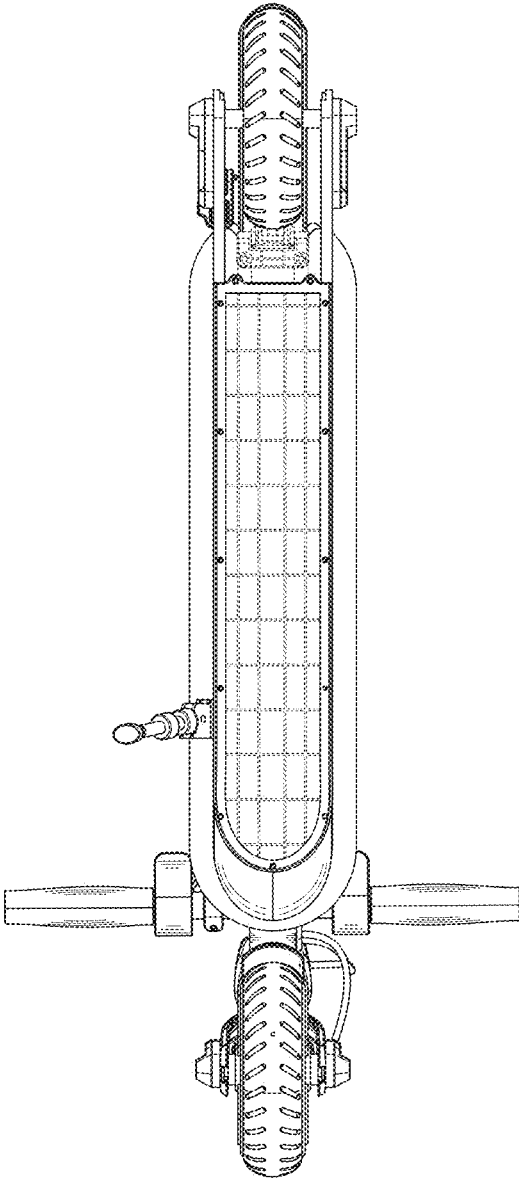

FIG. 8

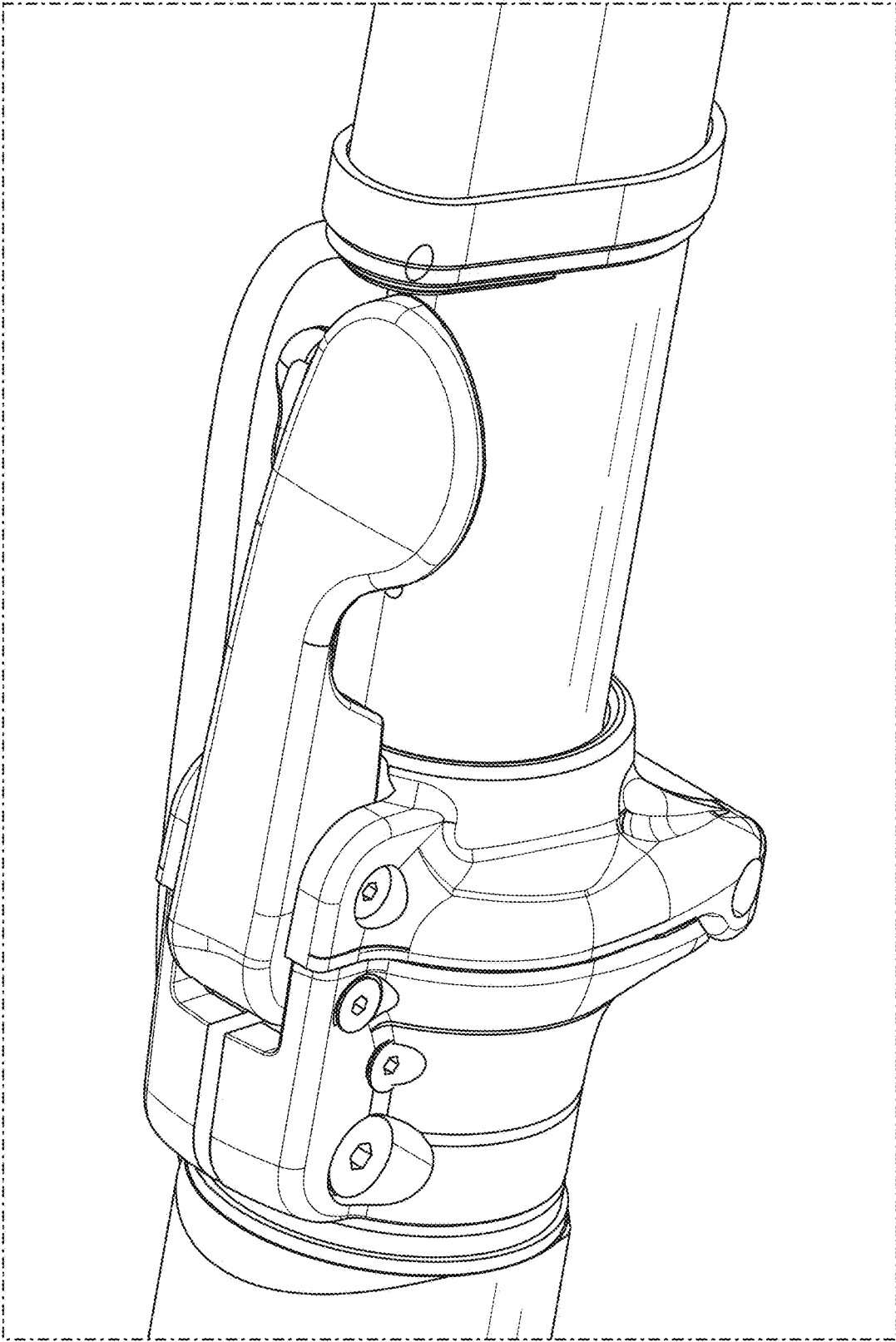

FIG. 9

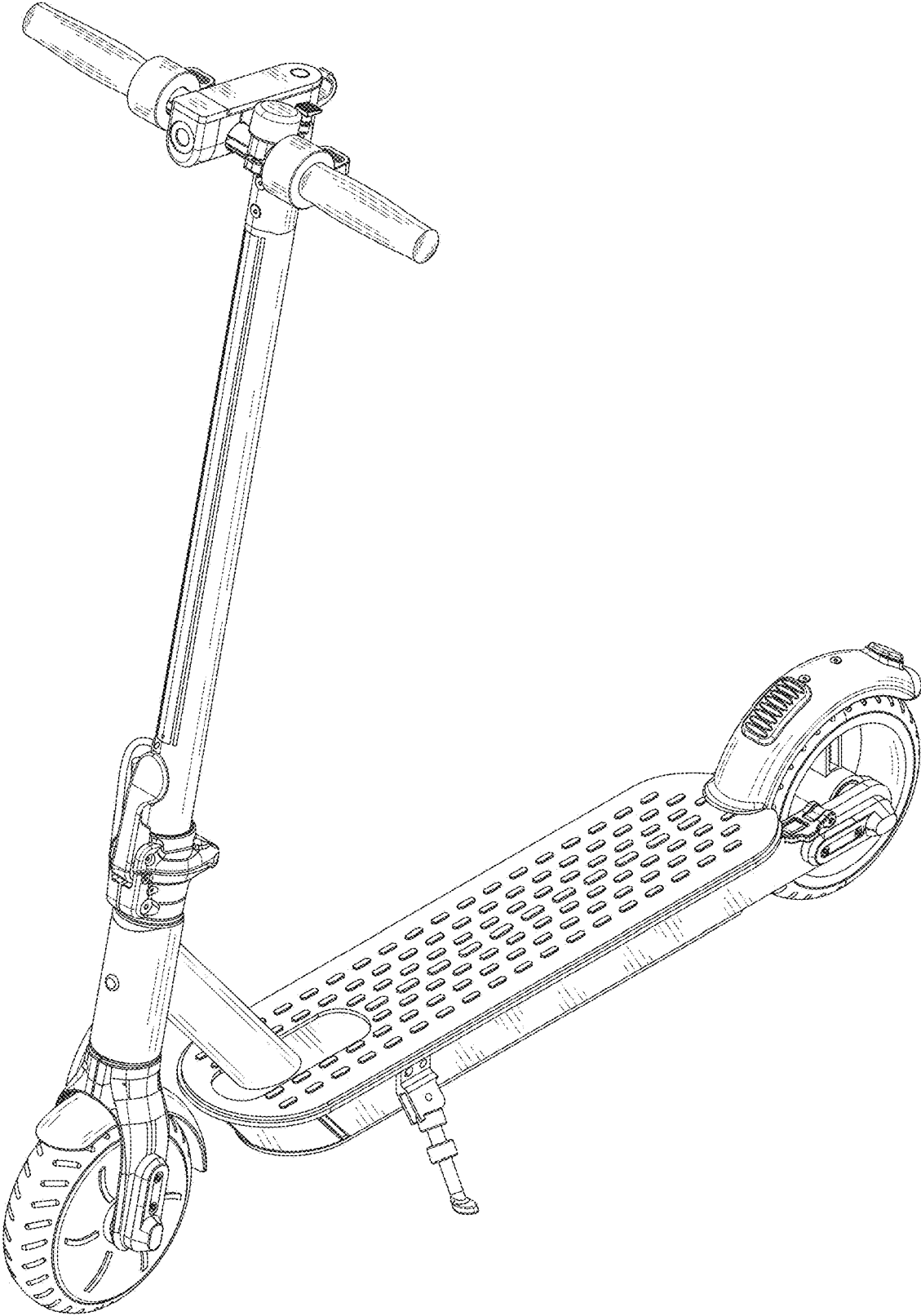

FIG. 10

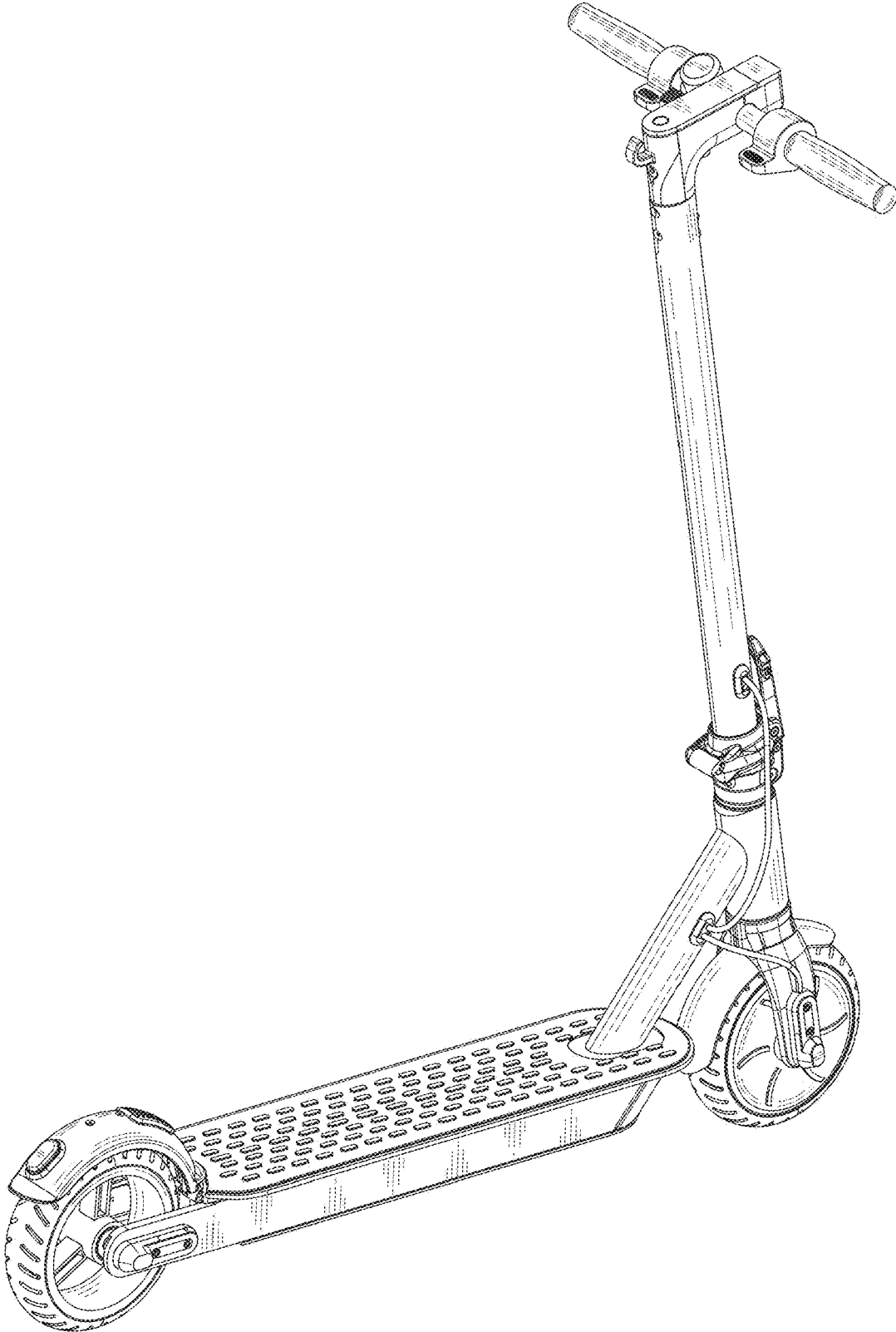

FIG. 11

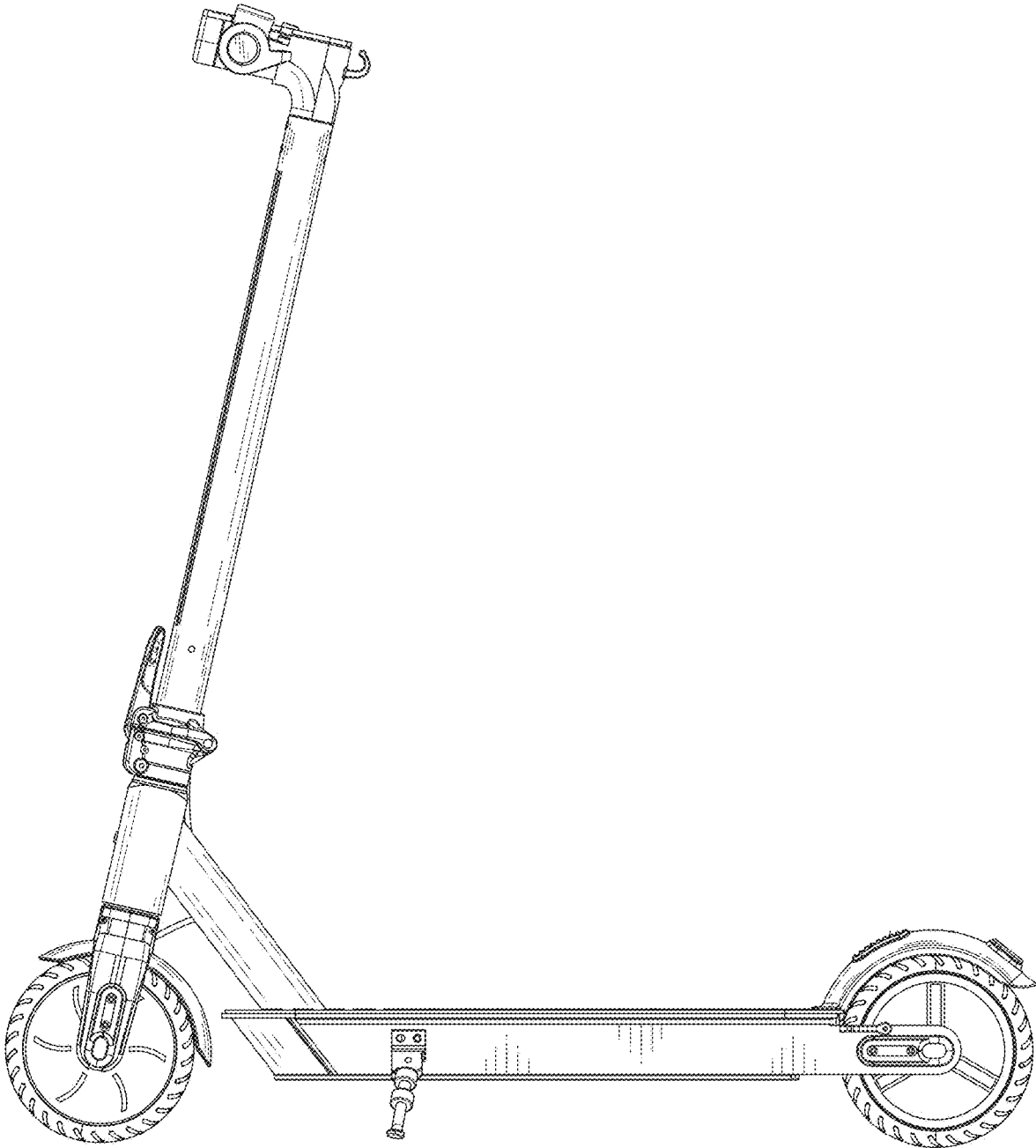

FIG. 12

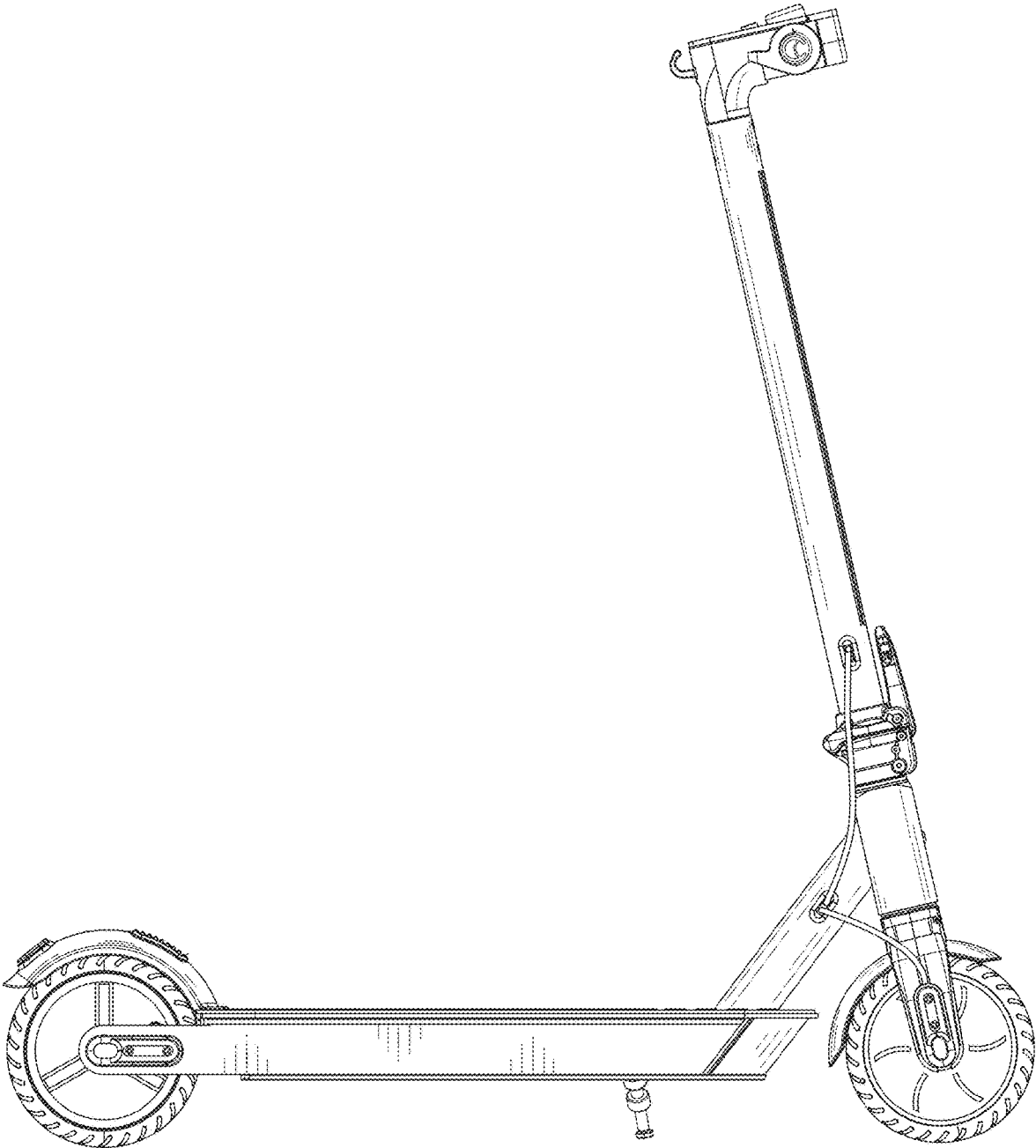

FIG. 13

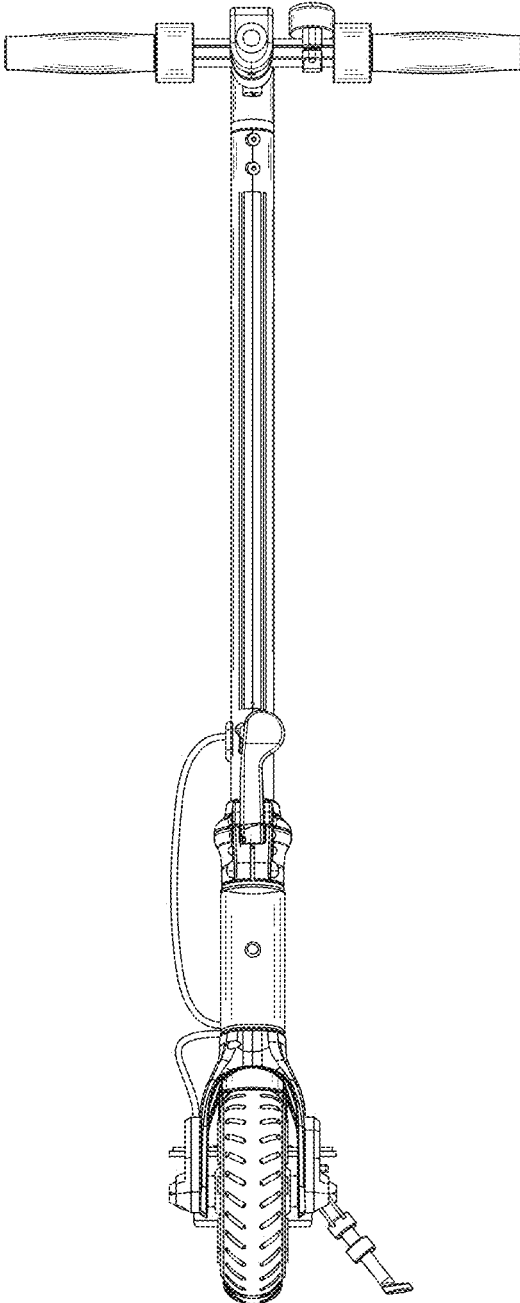

FIG. 14

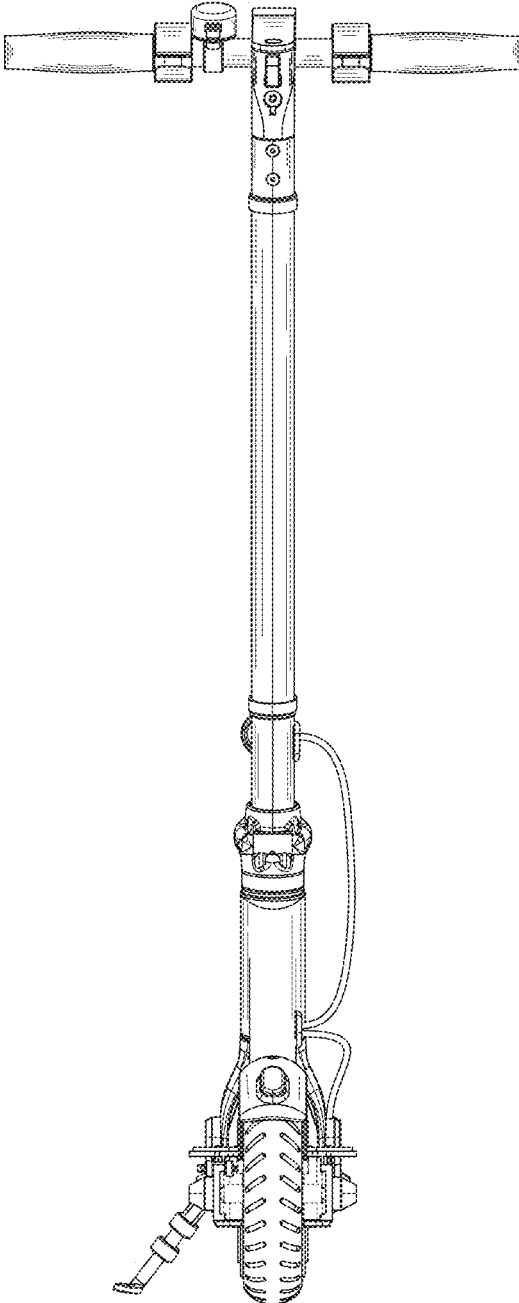

FIG. 15

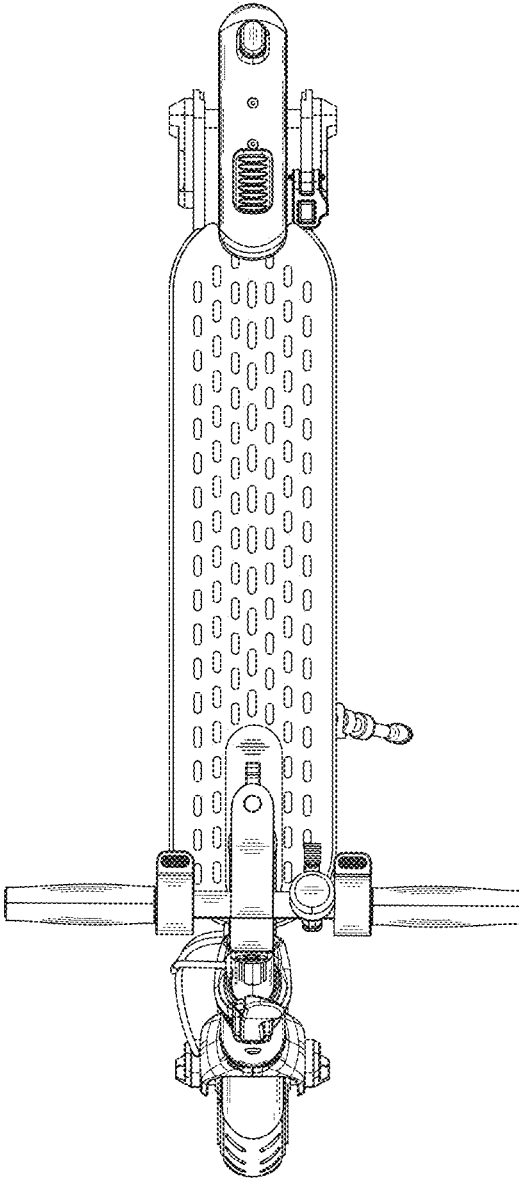

FIG. 16

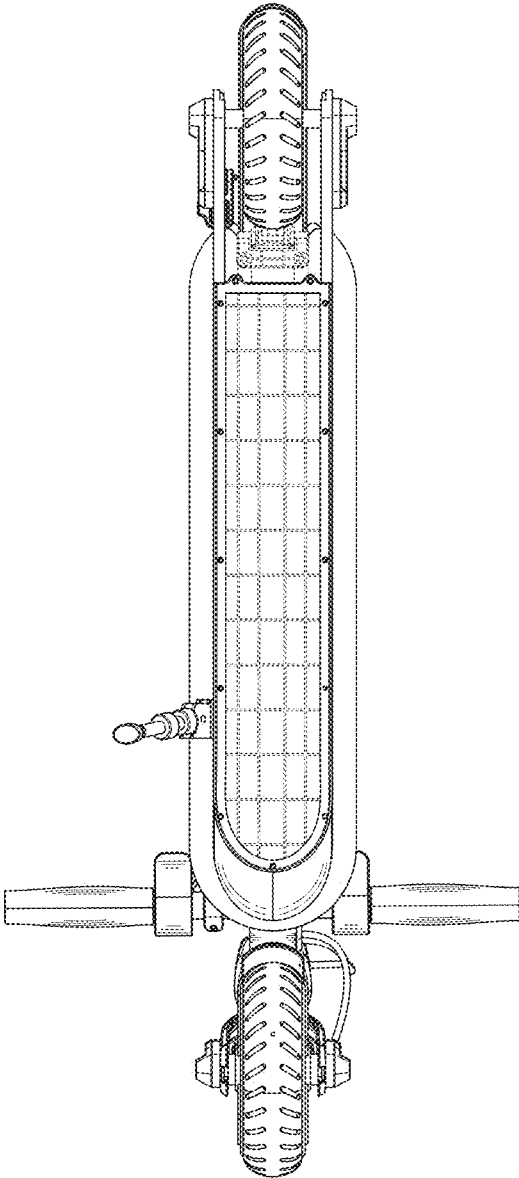

FIG. 17

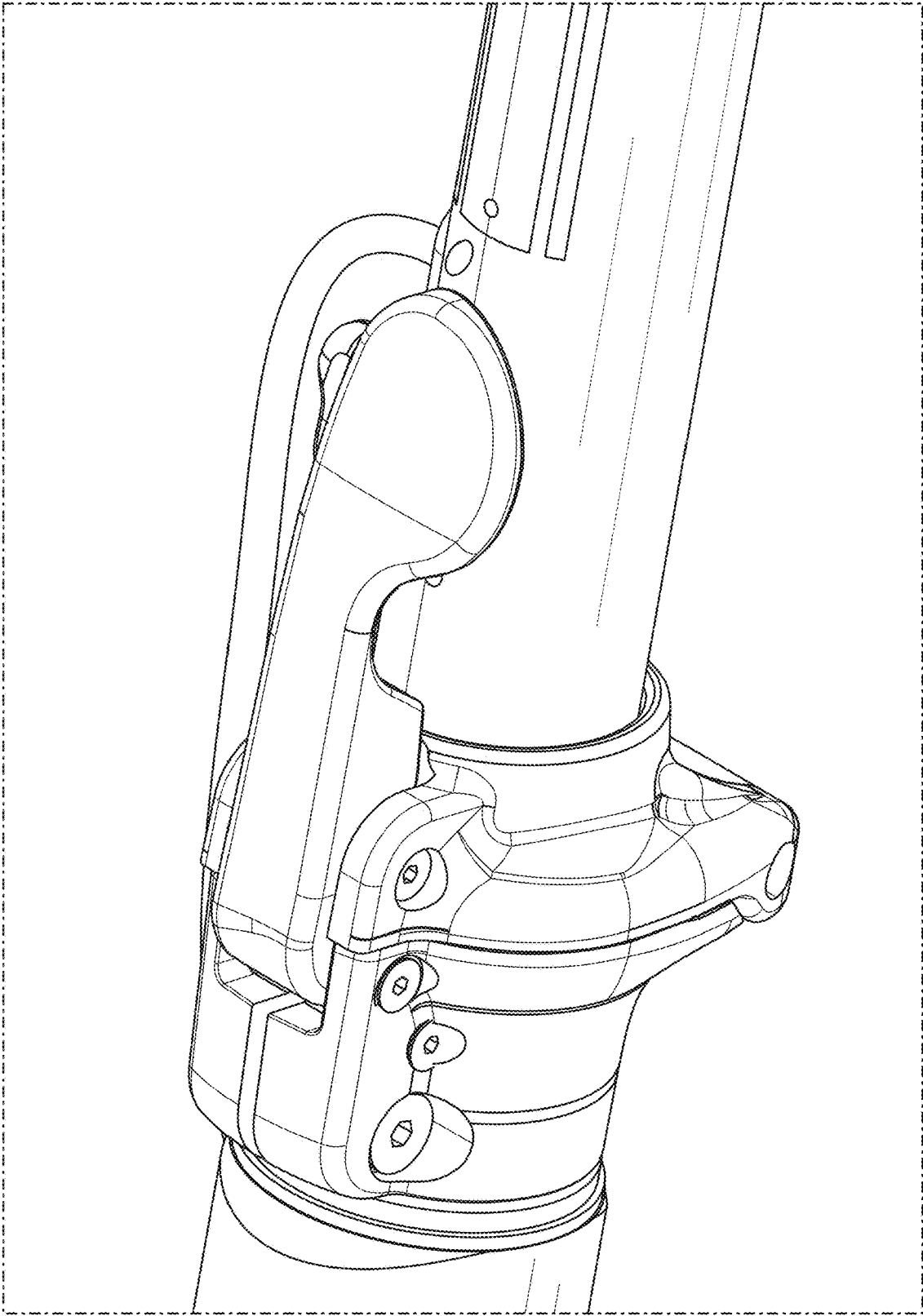

FIG. 18