

March 13, 1956

R. J. CLARKSON

2,737,773

APPARATUS FOR MAKING ELASTIC YARN

Filed July 24, 1952

2 Sheets-Sheet 1

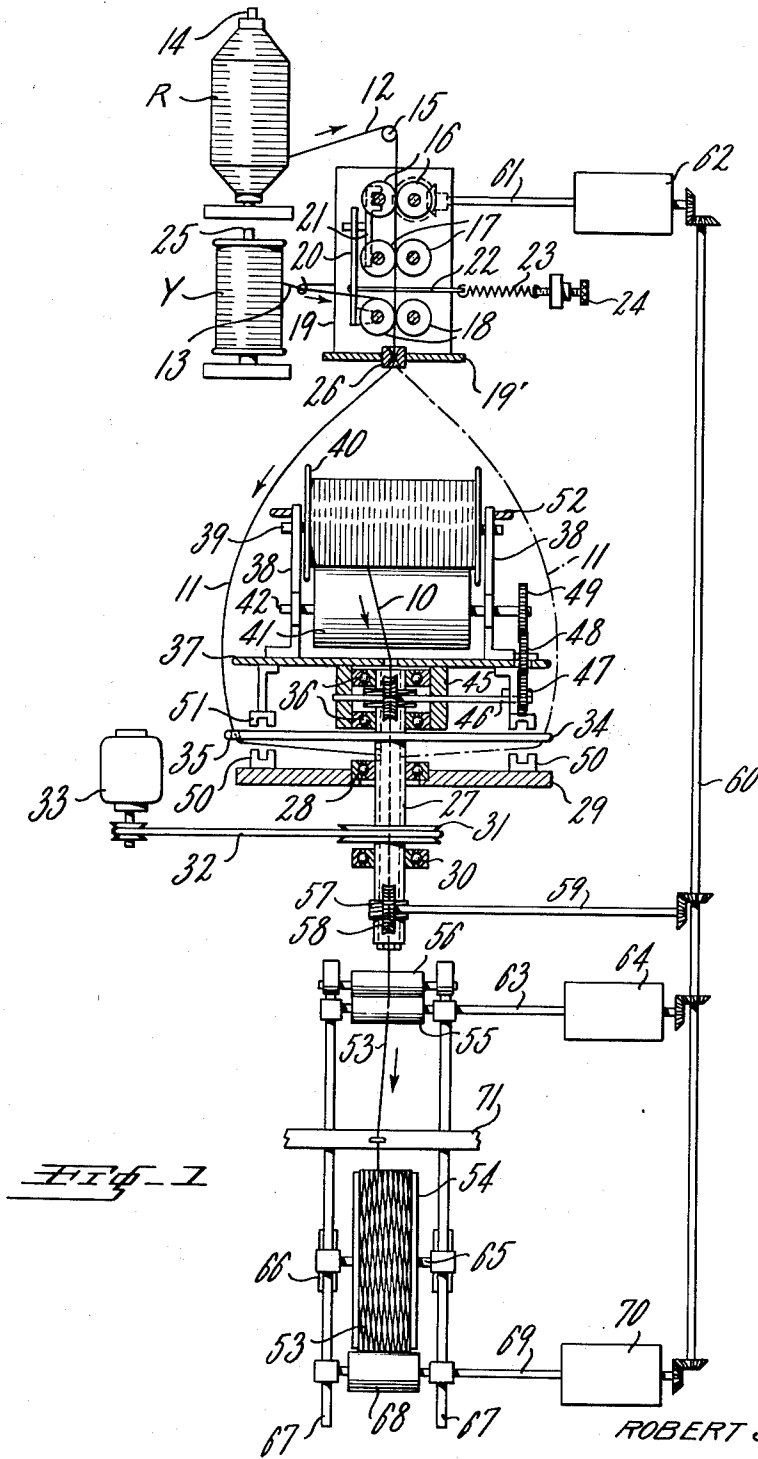

FIG. 1

INVENTOR.
ROBERT J. CLARKSON
BY Charles C. Willson

ATTORNEY

March 13, 1956

R. J. CLARKSON

2,737,773

APPARATUS FOR MAKING ELASTIC YARN

Filed July 24, 1952

2 Sheets-Sheet 2

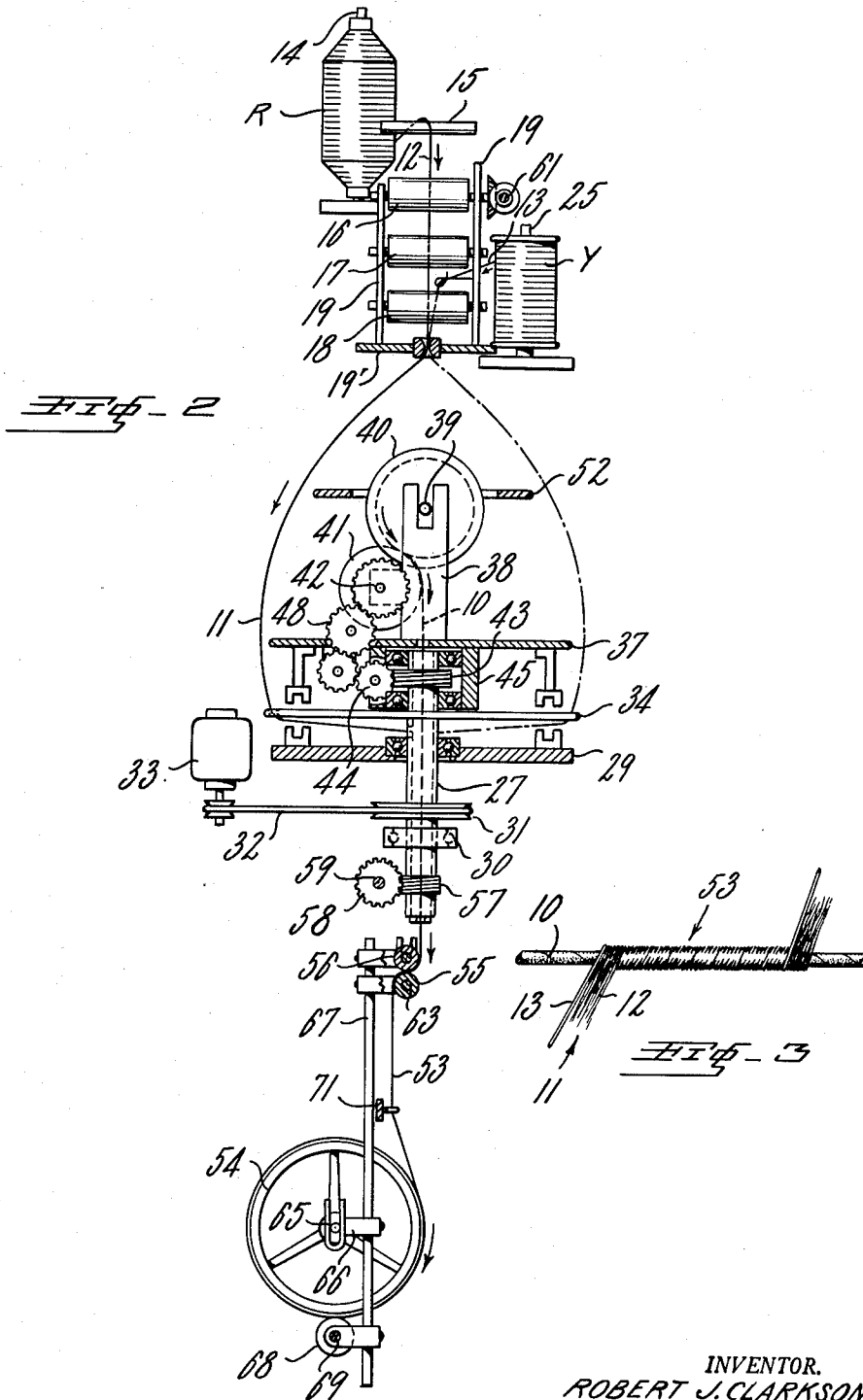

INVENTOR.
ROBERT J. CLARKSON
BY
Charles C. Willson
ATTORNEY

1

2,737,773

APPARATUS FOR MAKING ELASTIC YARN

Robert J. Clarkson, Winnsboro, S. C., assignor to United States Rubber Company, New York, N. Y., a corporation of New Jersey

Application July 24, 1952, Serial No. 300,704

7 Claims. (Cl. 57—3)

This invention relates to apparatus for making elastic yarn and in particular to apparatus for making elastic yarn of the type formed by winding a textile strand on a rubber core.

Heretofore it has been the usual practice to make elastic yarn by continuously feeding a rubber core through a rapidly rotating hollow spindle which carries a package of covering strand, and thereby wrap the covering strand around the rubber core by means of a ring and traveler or flier, as disclosed for example in the Cobb Patent No. 1,976,328.

Such prior apparatus for making elastic yarn, although used extensively, has a certain disadvantages from a manufacturing standpoint, one of these is the limitation as to the size of the package of the covering strand that may be used because of the high speed at which the package is rotated. The present practice on high-speed machines is to employ on such hollow rotating spindles strand packages that weigh about four or five ounces. This limitation as to package size necessarily results in comparatively short runs of the elastic yarn equipment, with accompanying expensive shut-down periods of the apparatus for replenishing the packages of covering strands.

One object of the present invention is to provide apparatus for forming elastic yarn in which the package of covering strand is not rotated so far as the covering operation is concerned, with the result that a large package of the textile covering strand can be employed. This results in a longer run of the elastic yarn, fewer shut-down periods of the apparatus, and decreased handling of the materials.

These advantages are secured by providing apparatus of the present invention which employs a rotating hollow shaft that operates to rotate a balloon of a covering strand around a package of rubber core thread, to wind or wrap the textile strand around the core thread as it is pulled from its package. In such a construction the package of rubber thread is supported by the rotating shaft, without being turned by such shaft, and no rotation of either the textile strand package or the rubber thread package takes place, other than that needed to unwind the textile strand and rubber core thread from their respective packages. By employing the apparatus of the present invention the package of textile strand and package of rubber thread may be a number of times as heavy as the textile strand packages used heretofore.

In the production of elastic yarn, it is extremely important that the amount of stretch in the rubber core thread be accurately controlled during the covering operation, otherwise the resulting elastic yarn will not be uniform as to its stretch characteristics. It is difficult to control accurately the stretch of the rubber core because of its elastic properties which cause its length to vary largely with slight changes in tension. Therefore mechanism which would be highly satisfactory for

2

working non-elastic textile yarn may be far from satisfactory for rubber core thread.

A further object of the present invention, therefore, is to provide apparatus for forming elastic yarn in which the stretch and tension of the rubber core thread is accurately controlled during the covering operation. To this end means are provided to unwind the rubber core thread from its package at a constant linear rate, regardless of the size of the package and to so remove this rubber thread from its package that its stretch will be uniform during the covering operation.

The above and other features of the present invention will be further understood from the following description when read in connection with the accompanying drawing; wherein,

Fig. 1 is a more or less diagrammatic front elevation of a core covering machine or elastic yarn machine constructed in accordance with the present invention;

Fig. 2 is a similar side elevation of the machine shown in Fig. 1; and

Fig. 3 is an enlarged side view of a short length of elastic yarn produced on the machine shown in Figs. 1 and 2.

The apparatus shown in the drawings is adapted to produce a single cover elastic yarn comprising the rubber core thread 10 having helically wound thereon a textile cover 11. When a single cover is wound about a rubber core as shown in Fig. 3 it tends to throw the elastic yarn thus produced out of balance so that a length of the same will tend to twist about its longitudinal axis. To overcome this difficulty and make the single cover elastic yarn balanced, the rubber core 10 is preferably twisted as shown in Fig. 3 before the cover is wound thereon, so that the twist of the rubber thread in one direction will tend to balance the helical windings of the cover 11 in the opposite direction. The cover 11 may be a single textile yarn or two or more textile yarns laid side by side, but as shown in the drawing this cover is formed of a drafted roving 12 reinforced with a fine yarn 13 disposed alongside of the roving as shown.

The apparatus of the present invention for producing the elastic yarn shown in Fig. 3 of the drawing will now be described. The various operating parts are supported by a machine frame, not shown. The operating parts are shown as supported so that the rubber core thread passes downwardly in a vertical direction during the covering operation.

In the construction shown the cover 11 is formed largely of a drafted roving 12, as a roving will form a softer cover than will yarn wound about the rubber core as a cover. This roving 12 is preferably reinforced with a small strong yarn 13 such as nylon to strengthen the roving during the covering operation and when the cover lays on the rubber core. The roving is conveniently supplied to the covering machine by a roving package R supported to rotate freely upon a spindle 14 as the roving is pulled off this package, and this roving is shown as passing from the package R around a guide bar 15 and then downwardly between pairs of drafting rolls 16, 17 and 18. The right-hand rolls 16, 17 and 18, viewing Fig. 1, are rotatably mounted in the uprights 19 and are power driven. The intermediate roll is driven faster than the upper roll, and the bottom roll is driven at a still higher peripheral speed to attenuate or draw out the fibers of a roving, in a well known manner. The left-hand rolls 16, 17 and 18 are free running and are mounted in the uprights 19 so that they can move horizontally, and these three rolls are continuously urged toward their companion rolls by levers 20 and 21. One end of the lever 20 acts upon the lower roll 18 while the upper end

of this lever presses against the upper lever 21. As shown, lever 21 acts on left hand rolls 16 and 17. The levers 20, 21 are continuously urged in a right-hand direction viewing Fig. 1 by connecting rods 22 and a spring 23, and the tension of this spring may be adjusted by operating the adjusting nut 24. As the roving 12 passes downwardly between the three pairs of drafting rolls it is attenuated in a well known manner.

As this roving passes between the nip of the lower rolls 18, in the construction shown, it meets the fine reinforcing yarn 13 which may be supplied to the spool Y rotatably mounted on the upright spindle 25 and this yarn is pulled forward from its spool by the rotation of the rolls 18. The drafted roving 12 and yarn 13 pass downwardly together from the rolls just mentioned to a guide eye 26 mounted in the base 19' of the frame 19 for the drafting rolls. This guide eye forms the apex for the covering yarn 11 as it balloons around the package of rubber core thread, to be described.

The covering operation contemplated by the present invention is produced by revolving the covering material 11 as a balloon about the stretched rubber core thread 10 so as to wind this cover helically upon the rubber core. In order to do this, it is necessary to support the supply of rubber core thread as a package inside of the balloon formed by the covering yarn. This is done by providing a hollow rotating spindle 27 which is shown as rotatably supported by the upper bearing 28 mounted upon the machine frame 29, and by the lower bearing 30 that is similarly supported. This spindle is rotated by a pulley 31 secured thereto and engaged by the belt 32 driven by the electric motor 33. The rotating spindle 27 has secured thereto near its upper end a disc 34 and in this disc is formed near its outer periphery a yarn guiding eye 35. The arrangement is such that rotation of the spindle 27 and the disc 34 attached thereto will rotate the covering strand 11 so that it will form the revolving balloon shown.

In carrying out the present invention, it is necessary to support the supply of rubber core thread 10 inside of the balloon just mentioned, and to this end the revolving spindle has mounted upon its upper end by anti-friction bearings 36 a platform 37 on which are mounted the spaced upright supports 38. These uprights are slotted at their upper ends as shown in Fig. 2 to slidably receive the spindle 39 that projects from the opposite ends of the spool 40 on which the rubber thread 10 is wound. This spool rests upon a power driven roller 41 that is mounted upon a shaft 42 journaled in the uprights 38. The arrangement is such that the rubber wound upon the spool 40 engages this power driven roller and such roller rotates the spool to unwind the rubber thread therefrom at a uniform speed irrespective of the size of this thread package.

The roller 41 is driven from the rotating spindle 27 so as to maintain a definite relation between the rate at which the rubber thread 10 is unwound from its supply package and the rate at which the covering strand 11 is wound on this rubber thread. The driving means shown for the roller 41 comprises a worm 43 rigidly secured to the spindle 27 and this worm drives the worm gear 44 which is rotatably supported in a housing 45 that is supported from the upper portion of the spindle through the bearings 36. The worm gear 44 drives a horizontal shaft 46, and this shaft through the gears 47, 48 and 49 drives the shaft 42 and roller 41 provided to unwind the thread 10 from its supply package.

It is important that the rapidly rotating spindle 27 serves to support the thread package 10 and driving means therefor without rotating the platform 37 which carries the spool 40 and associated parts. The bearings 36 permit the spindle 27 to rotate without rotating the platform 37, but since the rotating spindle may tend to turn the platform 37 this is prevented by providing the lower magnets 50, such as permanent magnets secured to the sup-

porting frame 29, and by providing the upper magnets 51 which are attached to the platform 37 as shown. The arrangement is such that the fixed lower magnets 50 will exert a downward pull on the upper magnets to thereby prevent the platform 37 from rotating, and this is done without interfering with the rotating of the ballooning thread 11. The rotating disc 34 is made of non-metallic material so that it will not interfere with the magnetic pull between the magnets. The outer edge of the circular platform 37 acts as a guide to hold the balloon out of contact with the spool 40 and associated parts, and an upper guide ring 52 performs a similar function.

The pre-twisted rubber thread 10 passes downwardly through the hollow rotating spindle 27 but the rotation of such spindle is not imparted to the rubber thread. The ballooning outer cover 11 passes from the guide eye 35 in the disc 34 inwardly to the spindle 27, and passes through a hole in a side of this hollow spindle to meet the downwardly moving rubber thread 10, to be wound thereupon as a cover by the rotation of the disc 34. As the ballooning cover yarn of the strand 11 passes downwardly from the guide 26 to the opening in the spindle 27 it has a false twist imparted thereto, which is desirable because it increases the strength of the roving 12 to improve its resistance to windage pull as it revolves rapidly in a balloon about the rubber thread package. This false twist disappears as the cover 11 is wound on the core 10 at a point within the hollow spindle 27.

The covering operation above described is finished by the time the covered rubber thread leaves the lower end of the hollow spindle 27, and the elastic yarn may then be wound on a spool or into a skein as desired. In the construction shown this finished elastic yarn which is herein designated by 53 is wound upon a reel 54, and before the elastic yarn reaches this reel it is preferably pulled downwardly at a uniform rate through the hollow spindle 27 by feed means such as the cooperating rolls 55 and 56, the lower roll being positively driven and the upper roll rests by gravity on the yarn passing between these two rolls.

It is important that all feeding means be driven in accurate timed relation with the rotation of the spindle 27 in order to produce a highly uniform elastic yarn. This is accomplished in the construction shown by providing the spindle 27 near its lower end with a worm 57 that drives a worm gear 58, which in turn drives a horizontally extending shaft 59 that serves to drive through suitable gears an upright shaft 60. This upright shaft 60 drives the various feed means. The upper end portion of this shaft through suitable gears drives a horizontal shaft 61 provided to drive the drafting rolls above described, and this shaft 61 preferably has associated therewith a variable speed box 62 whereby the ratio of the rotation of the shaft 61 may be varied with respect to its driving shaft 60. The shaft 60 serves also to drive the pull roll 55 by means of a horizontal shaft 63 and gears in the variable speed box 64. The take-up reel 54 has a supporting shaft 65 the ends of which rest in slotted brackets 66 mounted upon the frame 67. The arrangement is such that this reel is floatingly mounted and its weight is supported by a driving roll 68 that engages the elastic yarn wound upon this reel. The roll 68 is driven from the shaft 60 through the horizontal shaft 69 and change gear box 70. The elastic yarn 53 is guided onto the reel 54 by the traverse bar 71.

It will be seen from the foregoing that the upright shaft 60 is driven from the rotating spindle 27 at a definite relation thereto, and that by providing the variable speed boxes 62, 64 and 70, the speed at which the drafting rolls, elastic yarn take-up rolls, and yarn take-up reel are driven can be varied as desired, so that the machine may be readily set up to produce different sizes and types of elastic yarn.

Since, as a result of the construction of the present invention, no package is required to be rotated at the high

5

speed at which the hollow spindle 27 rotates relatively large supply packages may be used to supply the rubber thread and also the covering material, and the machine can be rotated for a long period of time without the need of stopping the same to replenish an exhausted supply package. Furthermore, since the rubber supply package 10 is rotated at a constant surface speed irrespective of its size, it will deliver its rubber thread at a uniform speed to the revolving spindle 27, and as the elastic yarn is produced it will be drawn downwardly through this hollow spindle at a constant rate by the take-up roll 55, 56 to be wound on the reel 54 under uniform tension.

The apparatus of the present invention may be employed to produce various sizes of covered elastic yarn, but it is particularly well adapted for use in producing relatively heavy elastic yarn where the supply packages, because of the coarseness of the yarn or rubber thread, are large and tend to become exhausted quickly.

The apparatus of the present invention has been herein described as making a balanced single cover elastic yarn, it may however be employed to provide a double cover elastic yarn in which one cover is an inner cover and the other is an outer cover. To accomplish this a single cover elastic yarn would be produced as above described and as shown in Fig. 3, except that the rubber core 10 need not be previously twisted. Such single cover elastic yarn may then be wound on a spool such as the spool 40 above described so that this covered elastic yarn will pass downwardly, through the rotating hollow spindle 27, and have a second cover wound thereon as a balloon by employing the apparatus shown in the drawings. This can be accomplished by passing such single cover elastic yarn downwardly through the revolving spindle 27 so that a second cover will be wound thereon in the opposite direction to that in which the first cover is applied.

It will therefore be seen that apparatus constructed in accordance with the present invention may be employed to produce a single cover elastic yarn or a double cover elastic yarn, and in each construction the stretch characteristics of the elastic yarn will be highly uniform, due to the accurate control of all feeding operations employed in producing such elastic yarn.

Having thus described my invention, what I claim and desire to protect by Letters Patent is:

1. A machine for making elastic yarn of the type formed by winding a textile cover on a rubber core, comprising a support carrying a package of textile strand, a support carrying a package of rubber core thread wound thereon under uniform tension, a revolving shaft that supports the second package and operates to rotate a balloon of the textile strand from the first package about the package of the rubber core thread to wind this textile strand around the rubber thread as a cover, control means for advancing the surface of said package of rubber thread at a constant predetermined linear rate to unwind the rubber thread therefrom, means spaced from said control means for advancing said rubber thread to the wrapping point at a constant predetermined linear rate, whereby said rubber thread is fed to the wrapping point under uniform tension, means for removing the textile strand from its package and for feeding the textile strand toward the wrapping point at a predetermined linear rate greater than that of the rubber thread and for winding this strand helically upon the rubber thread by the revolving action of the balloon and shaft.

2. A machine for making elastic yarn of the type formed by winding a textile cover on a rubber core, comprising a support carrying a package of textile strand, a support carrying a package of rubber core thread wound thereon under uniform tension, a revolving shaft that supports the second package and operates to rotate a balloon of the textile strand from its package around the package of rubber core thread to wind the textile strand around the rubber core as a cover, control means for advancing the surface of said package of rubber thread at a

6

constant predetermined linear rate to unwind the rubber thread therefrom, means spaced from said control means for advancing said rubber thread to the wrapping point at a constant predetermined linear rate, whereby said rubber thread is fed to the wrapping point under uniform tension, means for removing the textile strand from its package and for feeding the textile strand toward the wrapping point at a predetermined linear rate greater than that of the rubber thread so as to control the length of the strand wound on the core by the revolving action of the balloon and shaft, and means for taking up the formed elastic yarn and for winding it into a package.

3. A machine for making elastic yarn of the type formed by winding a textile cover on a rubber core, comprising a support carrying a package of textile strand, a support carrying a package of rubber core thread wound thereon under uniform tension, a revolving shaft that supports the second package and operates to rotate a balloon of the textile strand from its package around the package of rubber core thread to wind the textile strand helically upon the rubber core, control means for advancing the surface of said package of rubber thread at a constant predetermined linear rate to unwind the rubber thread therefrom, means spaced from said control means for advancing said rubber thread to the wrapping point at a constant predetermined linear rate, whereby said rubber thread is fed to the wrapping point under uniform tension, means for removing the textile strand from its package and for feeding the textile strand toward the wrapping point at a predetermined linear rate greater than that of the rubber thread and for winding this strand helically upon the rubber thread by the revolving action of said shaft, and mechanism for driving each of said means at a definite relation to the speed of said shaft.

4. A machine for making elastic yarn of the type formed by winding a textile cover on a rubber core, comprising a support carrying a package of textile strand, a support carrying a package of rubber core thread wound thereon under uniform tension, a revolving shaft that supports the second package and operates to rotate a balloon of the textile strand from its package around the package of rubber core thread to wind the textile strand helically upon the rubber core, a driving roll in contact with the thread surface of the package of rubber core thread, means for driving said roll from said shaft whereby the surface of said package of rubber thread is advanced at a constant predetermined linear rate to remove the rubber thread therefrom, means spaced from said driving roll for advancing said rubber thread to the wrapping point at a constant predetermined linear rate, whereby said rubber thread is fed to the wrapping point under uniform tension, means for removing the textile strand from its package and for feeding the textile strand toward the wrapping point at a predetermined linear rate greater than that of the rubber thread to be wound upon the rubber thread by the revolving action of said shaft.

5. A machine for making elastic yarn of the type formed by winding a textile cover on a rubber core, comprising a support carrying a package of textile strand, a support carrying a package of rubber core thread wound thereon under uniform tension, a revolving shaft operable to rotate a balloon of the textile strand from its package around the package of rubber core thread to wind the textile strand helically upon the rubber core, a driving roll in contact with the thread surface of the package of rubber core threads, means connected with said shaft for driving said roll at a predetermined linear rate to unwind the rubber thread from its package, means spaced from said driving roll for advancing said rubber thread to the wrapping point at a constant predetermined linear rate, whereby said rubber thread is fed to the wrapping point under uniform tension, means for removing the textile strand from its package and for feeding the textile strand toward the wrapping point at a predetermined linear rate greater than that of the rubber thread so that it is wound

7

about the rubber thread by said revolving shaft, and tension take-up means for uniformly taking up the elastic yarn as it is formed.

6. A machine for making elastic yarn of the type formed by winding a textile cover on a rubber core, comprising a support carrying a package of textile strand, a spool having rubber core thread wound thereon under uniform tension, means for rotatably supporting the spool, a driving roll carried by said supporting means below said spool and in frictional contact therewith whereby the spool is rotated by the friction roll to remove the rubber core thread therefrom at a constant predetermined linear rate to impart a uniform tension to the rubber core thread, means for removing the textile strand from its package at a greater predetermined linear rate than that of the rubber core thread, a revolving shaft operable to rotate a balloon of the textile strand from its package around said spool to wind the textile strand around the rubber core thread to form an elastic yarn, and tension take-up means for taking up the formed elastic yarn and for insuring that the rubber core thread is stretched a predetermined amount while the textile strand is being wound thereon.

7. A machine for making elastic yarn of the type formed by winding a textile cover on a rubber core, comprising a support carrying a package of textile strand, a spool having rubber thread wound thereon, means for

8

supporting the spool including a driving roll supported so that the rubber thread of the spool engages the roll and is turned thereby at a speed that will remove the rubber thread from the spool at a predetermined constant linear rate, means for removing the textile strand from its package at a greater predetermined linear rate than that of the rubber core thread, a revolving shaft operable to support said spool and to rotate a balloon of the textile strand from its package around said spool to wind it on the rubber core thread to form an elastic yarn, take-up means for taking up the formed elastic yarn so as to insure that the rubber core thread is stretched a predetermined amount while the textile strand is being wound thereupon, and mechanism for driving said roll and each of said means at a definite relation to the speed of said shaft.

References Cited in the file of this patent

UNITED STATES PATENTS

20	1,728,066	Lay	Sept. 10, 1929
	2,290,628	Alderfer	July 21, 1942
	2,343,535	Clarkson	Mar. 7, 1944
	2,387,869	Arrington	Oct. 30, 1945
	2,400,697	Lewis	May 21, 1946
25	2,442,775	Nelson	June 8, 1948
	2,503,242	Clarkson	Apr. 11, 1950