

(19) World Intellectual Property Organization
International Bureau



(43) International Publication Date
29 March 2001 (29.03.2001)

PCT

(10) International Publication Number
WO 01/21395 A1

- (51) International Patent Classification⁷: **B32B 7/06**, G09F 3/00
- (21) International Application Number: PCT/US00/26335
- (22) International Filing Date:
25 September 2000 (25.09.2000)
- (25) Filing Language: English
- (26) Publication Language: English
- (30) Priority Data:
09/404,429 23 September 1999 (23.09.1999) US
- (71) Applicant: NATIONAL LABEL COMPANY [US/US];
2025 Joshua Road, Lafayette Hill, PA 19444 (US).
- (72) Inventor: SELLARS, Neil, G.; 2120 Magnolia Court,
Cinnaminson, NJ 08077 (US).
- (74) Agent: GOLDSCHMIDT, John, W., Jr.; Reed Smith
Shaw & Mc Clay LLP, 2500 One Liberty Place, 1650 Mar-
ket Street, Philadelphia, PA 19103 (US).
- (81) Designated States (*national*): AE, AG, AL, AM, AT, AU, AZ, BA, BB, BG, BR, BY, BZ, CA, CH, CN, CR, CU, CZ, DE, DK, DM, DZ, EE, ES, FI, GB, GD, GE, GH, GM, HR, HU, ID, IL, IN, IS, JP, KE, KG, KP, KR, KZ, LC, LK, LR, LS, LT, LU, LV, MA, MD, MG, MK, MN, MW, MX, MZ, NO, NZ, PL, PT, RO, RU, SD, SE, SG, SI, SK, SL, TJ, TM, TR, TT, TZ, UA, UG, UZ, VN, YU, ZA, ZW.
- (84) Designated States (*regional*): ARIPO patent (GH, GM, KE, LS, MW, MZ, SD, SL, SZ, TZ, UG, ZW), Eurasian patent (AM, AZ, BY, KG, KZ, MD, RU, TJ, TM), European patent (AT, BE, CH, CY, DE, DK, ES, FI, FR, GB, GR, IE, IT, LU, MC, NL, PT, SE), OAPI patent (BF, BJ, CF, CG, CI, CM, GA, GN, GW, ML, MR, NE, SN, TD, TG).

Published:
— With international search report.

For two-letter codes and other abbreviations, refer to the "Guidance Notes on Codes and Abbreviations" appearing at the beginning of each regular issue of the PCT Gazette.

(54) Title: EXTENDED WRAP LABEL

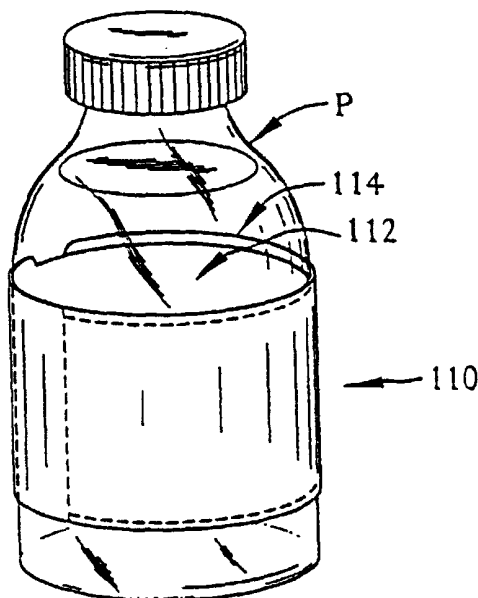

(57) Abstract: A unitary label (110) adapted for fixation to an object (P) such as a product container. The label (110) includes a first portion (112) and a second portion (114) contiguous with the first portion (112). The label is wrapped about the target object (P) and the combined length of the label (110) is greater than the circumference of the object (P) whereby the second portion (114) functions as a resealable and/or removable flap which offers additional available print areas on both its top and bottom surfaces. A method for making the unitary label (110) is also disclosed.

WO 01/21395 A1

EXTENDED WRAP LABEL**FIELD OF THE INVENTION**

The present invention relates in general to labels and, more particularly, to labels for products and product containers.

5

BACKGROUND OF THE INVENTION

Labels, typically in the form of flexible sheet or web material attached to an object, have long been used to identify the object, its contents and/or display other information associated with the object. Such labels, which are normally fabricated from paper or plastic, are usually adhesively secured to the object by a contact or pressure sensitive adhesive material.

10

Many objects such as jars, bottles, cans and similar receptacles support "wrap" labels which cover substantially all of their circumferential side wall surfaces. With these labels, essentially the entire outer surface of the label is available as an indicia bearing surface. A label covering all or nearly all of the circumferential area of an object such as a product container is oftentimes sufficient to convey desired advertising, content information, instructions, warnings, and the like. In many circumstances, however, an object's physical dimensions detrimentally limit the available print space of the label borne thereby.

15

A common solution to the problem of limited label print area, as taught for example in U.S. Patent Nos. 5,458,374, 5,439,721 and 5,403,636, is to affix an additional multi-sheet leaflet or "outsert" to the exterior of the label. While generally effective for providing additional print space, such leaflets complicate the label assembly process in that at least three fabrication steps must be performed, apart

20

from printing and placement of any necessary adhesive and release layers, in order to manufacture the label. That is, the base label must be cut to desired dimensions, the leaflet must be similarly cut and/or folded, and the leaflet must be secured to the base label. Moreover, the multiple layers of the leaflet may add considerable thickness and
5 bulk to the label construction. Such label designs may also be unwieldy to the end user of the product if the leaflet is folded in a complicated pattern and is difficult to refold into its compact folded initial configuration. Further, because the base label and leaflet are discrete parts which must be joined to one another during the assembly process, the possibility exists that the leaflet may become detached from the base
10 label and thereafter become misplaced. In that event, the additional printed information borne by the leaflet and, thus, the utility of the leaflet itself are lost.

An advantage exists, therefore, for a unitary, i.e., one-piece, label construction which offers enhanced printable surface area capacity versus wrap labels of conventional design.

15 Other details, objects and advantages of the present invention will become apparent as the following description of the presently preferred embodiments and presently preferred methods of practicing the invention proceeds.

SUMMARY OF THE INVENTION

20 These objects are achieved by providing a unitary label suitable for attachment to an object having a circumference. The label comprises a first label portion; a first adhesive means for affixing the first label portion about the circumference of the object; and a second label portion contiguous with the first label portion and operable to overlies the first label portion when the label is affixed to the

object, wherein the first label portion and the second label portion have a combined length which is greater than the circumference of the object.

BRIEF DESCRIPTION OF THE DRAWINGS

5 The invention will become more readily apparent from the following description of preferred embodiments thereof shown, by way of example only, in the accompanying drawings wherein:

Figure 1 is a perspective view of a conventional wrap-type label affixed to a product container;

10 Figure 2 is a top plan view of a first embodiment of a label constructed in accordance with the present invention;

Figure 3 is a top plan view of a further embodiment of a label constructed in accordance with the present invention;

Figure 4 is a top plan view of a further embodiment of a label constructed in accordance with the present invention;

15 Figure 5 is a perspective view of a label according to the present invention with a releasable end thereof lifted from the surface of a product container to which the label is affixed;

20 Figure 6 is a perspective view of the label of Figure 5 with the releasable end thereof attached to the surface of the product container to which the label is affixed;

Figures 7, 8 and 9 are top plan views of labels according to the present invention including means for facilitating separation of a second portion of the label from a first portion thereof;

Figure 10 is a top plan view of a further embodiment of a label
5 constructed according to the present invention having a tear strip;

Figure 11 is a perspective view of the label of Figure 10 shown wrapped about the circumference of a substantially cylindrical product container;

Figure 12 is a perspective view similar to Figure 11 with said tear strip removed;

Figure 13 is a schematic depicting a method for making the labels of
10 this invention;

Figure 14 is a schematic depicting a further method for making the labels of this invention;

Figure 15 is a schematic depicting yet a further method for making the
15 labels of this invention;

Figure 16 is a schematic depicting yet another method for making the labels of this invention;

Figure 17 is a schematic depicting another method for making the labels of this invention; and

Figure 18 is a top plan view of a further embodiment of a label
20 constructed in accordance with the present invention

DETAILED DESCRIPTION OF THE INVENTION

Referring to Figure 1, there is shown an object such as a product container P, e.g., a bottle, jar, or the like. Adhesively affixed about the circumferential side wall of container P is a wrap-type label 10. Label 10, as is conventional, may cover any fraction of the circumferential side wall of container P. As illustrated, label 10 is constructed as an elongated strip member spanning nearly the entire circumference of container P such that the ends of the label are separated by a small gap G. The available printing area of such a label is limited by the area, (i.e., length and width) dimensions of the label. Additionally, printing is normally carried only by the exposed exterior surface of the label.

Figures 2, 3 and 4 depict several presently preferred embodiments of labels which alleviate the problem of limited print space associated with conventional wrap labels such as label 10 of Figure 1. Furthermore, as will be described in greater detail in connection with Figures 3 and 4, labels constructed in accordance with the present invention may incorporate structural features which impart additional functions and advantages to the label.

The labels according to the present invention, respectively identified by reference numeral 110 in Figure 2, 210 in Figure 3 and 310 in Figure 4, include several common characteristic features. For instance, each may be comprised of a flexible and printable substrate such as paper or plastic sheet or web material. Although they may be made individually, the labels are preferably produced from rolls of such substrates, such as paper or plastic sheet stock which can be continuously printed, coated with adhesive, applied with protective material, affixed to release paper, and cut to produce multiple labels as further described herein.

Additionally, each label has general areal dimensions L and W which represent the length and width dimensions, respectively, of the label. Length L is a predetermined distance related to the circumferential dimension of the object to be labeled and width W is that dimension extending perpendicularly to length L. Width W may vary, as
5 may be desired or necessary, along length L.

As used herein, the terms "circumferential," "circumference," or variants thereof shall be construed to include any distance circumscribing the perimeter of the target object to be labeled. The object may comprise a polygonal shape (e.g., square or rectangular), curvilinear shape (e.g., circular or oval) or
10 composite polygonal and curvilinear cross-sectional configuration defining a desired perimetrical exterior wall surface to be covered by label 110, 210, 310, 410, 510, 610, 710 or any other label disclosed herein.

Labels 110, 210 and 310 each include a first portion 112, 212 and 312, respectively, having a length L_1 . L_1 is preferably less than or equal to the
15 circumferential dimension of the object to be labeled. In addition, labels 110, 210 and 310 include second portions 114, 214 and 314, respectively, of length L_2 which are contiguous with first portions 112, 212 and 312. Second label portions 114, 214 and 314 provide additional length to first label portions 112, 212 and 312 such that the total length L of the labels 110, 210 and 310 is greater than the circumference of the
20 object to be labeled. All or a portion of the underside of first label portions 112, 212 and 312 may be coated with a layer of pressure sensitive or other adhesive having sufficient tackiness to essentially affix the label on the target object, such adhesive being respectively identified by dot-dash lines 116, 216 and 316.

Each of the second label portions 114, 214 and 314 provides additional print space to labels 110, 210 and 310. Indeed, both the top and bottom surfaces of the second label portions are available as printable surfaces. Further, depending on which of certain other structural features, described below, are incorporated into the label of the present invention, second label portions 114, 214 and 314 may function, without limitation, as resealable and/or removable flaps.

The length L_2 of second portions 114, 214 and 314 is dictated by, inter alia, the need for additional print space. The primary practical limitation on the second label portion length L_2 and, hence, the overall length L of labels 110, 210 and 310 is that, if L_2 results in multiple wraps of the second label portion 114, 214 and 314 about the target object, the several superimposed label layers may produce a label whose bulk and thickness rivals those of presently available two-part (base label and leaflet) label constructions. However, the label of this invention may include any number of wraps of the second label portion about the target object. In fact, the multiple wraps embodiment of this invention may be preferable to known leaflet labels because multiple wraps provide, in most cases, an equal or greater amount of print area than would an equivalent leaflet label while providing a substantially uniform overall diameter to container P. A leaflet label providing an equivalent amount of print area would produce a bulge on the side wall of container P at the point where the leaflet is located thereby creating a non-symmetric overall cross section to container P.

Referring more specifically to Figures 2, 3 and 4, Figure 2 represents the simplest expression of the present invention. According to this embodiment, label 110 comprises first and second portions 112, 114 which are contiguous regions of an

elongated unitary strip of material. No perforation exists between first and second label portions 112 and 114. Physical demarcation between first label portion 112 and second label portion may be established by the rightmost edge of the pressure sensitive adhesive 116 underlying first portion 112. The boundary between the first and second label portions 112 and 114 may also be distinguished by a change in width W and/or the printed image carried on the label.

Figures 5 and 6 are sequential views of the label 110 being applied to an object, e.g., a product container P.

Referring initially to Figure 5, first label portion 112 of label 110 is shown wrapped about and adhered to the circumference of container P and second label portion 114 is depicted in a lifted and turned-away disposition to expose the bottom surface 118 thereof. Both the top and bottom surfaces of second portion 114 are available as printable surface areas. To enhance the utility of label 110, a comparatively narrow strip of tack adhesive material 120 may be provided along the distal edge of the bottom surface 118 of the second label portion 114. Alternatively, tack adhesive 120 may be applied in any pattern and to any area of bottom surface 118 of second portion 114 and to as much as the entire bottom surface 118. The tackiness of adhesive material 120 should be such that it may enable the second label portion 114 to be selectively and repeatedly adhered to the first label portion 112 substantially in the manner shown in Figure 6 and released from the first label portion as in Figure 5 to expose the bottom surface 118 of second label portion 114 at the end user's discretion. Preferably, where the strip of tack adhesive 120 is employed, the label stock is coated with adhesive to enable the strip to releasably adhere to the top surface of the first label portion.

Although second label portion 114 may be of any length, an example best illustrates the degree to which a second label portion 114 of relatively moderate length increases the available print surface area of label 110. Assuming that product container P is a generally cylindrical jar or bottle such as in Figures 5 and 6, length L_1 of the first portion 112 of label 110 is selected to be substantially equal to that of the circumference of container P. Recalling that both the top and bottom surface of the second label portion 114 may be printed, if the length L_2 of the second portion 114 is chosen so as to extend for an additional 360° of arc about the circumference of container P, then the total available print surface area is increased by 200% as compared to the available print surface area of conventional 360° wrap labels. That is, 720° of additional printable surface area is created in a label which consists of no more than two superimposed layers wrapped about container P. As a consequence, a compact, low-bulk and low thickness resultant label construction is produced which offers essentially three times the print area of a presently existing wrap label such as label 10 of Figure 1.

Figure 3 represents a further embodiment of the present invention. According to Figure 3, label 210 is substantially similar in construction to label 110. Hence, only those features which materially distinguish label 210 from label 110 will be described in detail.

Unlike label 110, label 210 includes a perforation 222 which may be placed at or, as illustrated, near the boundary between the first label portion 212 and the second label portion 214. Although not illustrated, second label portion 214 may also include a thin strip of tack adhesive on the bottom surface and at the distal end thereof similar to adhesive material 120 of label 110 (Figure 5) or in any pattern or to

any area of the bottom surface of the second portion. So disposed, the tack adhesive serves to retain the second label portion 214 in contact with the first label portion 212 until deployment of the second label position is desired. In this way, some or all of the second label portion 214 can be torn from the first label portion 212 along
5 perforation 222 to expose the surface of the first label portion previously covered by the second label portion. Additionally, the second label portion according to this embodiment may be adapted for a use, once detached from the first label portion, that is independent of the function of the first label portion. For instance, second label portion 214 may be printed with information such that it may function as a
10 redeemable coupon for consumer merchandise.

Figure 4 represents another embodiment of the label according to the invention. The label 310 depicted therein, like label 210, includes a perforation 322 generally at or near the boundary between first label portion 312 and second label portion 314. Additionally, second label portion 314 is provided with a pair of
15 comparatively closely spaced perforations 324 and 326 disposed adjacent the end of the second label portion 314 opposite the first label portion 312. Perforations 324, 326 together define a removable tear strip 328, described below, which separates the second label portion 314 into a first non-adhesive-bearing, removable segment 314a and a second adhesive-bearing segment 314b. Alternatively, a single perforation may
20 be located in second label portion 314 in order to separate second label portion 314 from segment 314b.

The bottom surface of the second label segment 314b is preferably coated with a pressure sensitive or other adhesive (not illustrated) similar to adhesive 316 provided on the first label portion 312. In this way, when label 310 is fully

wrapped about an object such as product container P such as that shown in Figures 1, 5 and 6, the first label portion 312 is essentially affixed to the circumferential wall of the container and the second segment 314b of the second label portion 314 is similarly affixed to the first label portion 312. Alternatively, if L_2 is greater than the circumference of container P, second segment 314b of second label portion 314 may be affixed to second label portion 314.

With respect to the embodiment shown in Figure 4, in order to detach the first removable segment 314a, therefore, the end user simply grasps and pulls the tear strip 328 (which also preferably has no adhesive on its bottom surface, although it may contain adhesive on such surface) thereby severing the tear strip from the first and second segments 314a, 314b along perforations 324, 326. Thereafter, the user grasps and pulls the first segment 314a to sever it from the first label portion 312 along perforation 322. At this stage, the area of the first label portion 312, as well as any area of second label portion 314, previously covered by the first label segment 314a of the second label portion 314 is exposed. And, if so designed, the detached first label segment 314 may perform an additional function, e.g., as a redeemable coupon or the like. Additionally, tack adhesive 120 (not shown in Figure 4) may also be added to the bottom surface of segment 314a in a fashion similar to that for labels 110 and 210 in order to provide a resealable means for segment 314a. And, if so designed, the first label segment 314 may perform an additional function, e.g. as a resealable segment.

Figures 7, 8 and 9 illustrate further embodiments of a product label constructed according to the present invention, identified respectively by reference numerals 410, 510 and 610. It will be understood that labels 410, 510 and 610 may be

constructed substantially similarly to any of the label embodiments disclosed herein including, but not limited to, labels 110, 210 and 310 described above or label 710 discussed below. Hence, only those structural aspects of labels 410, 510 and 610 which materially depart from those previously addressed, or whose description may otherwise
5 be necessary for a proper understanding of the invention, will be described in detail.

More particularly, labels 410, 510 and 610 depict exemplary, although not limitative, means for facilitating separation of the releasable second portions of the labels from the first portions thereof when the labels are secured to objects such as products or product containers. These means may include a protrusion 430 provided
10 adjacent a distal end of the second portion 414 of label 410, a notch 532 adjacent an end of the first portion 512 of label 510, or a combination of a notch 630 adjacent a distal end of second portion 614 and a notch 632 adjacent an end of the first portion 612 of label 610. Each of these means enable easier insertion of a user's finger or fingernail beneath the releasable second portion of any of the labels herein described when such
15 labels are affixed to a product or product container whereby the second label portion may be more easily lifted and separated from contact with the first label portion.

Figures 10, 11 and 12 reveal a further presently preferred embodiment of a product label 710 constructed in accordance with the present invention. Label 710 may be manufactured in a substantially similar manner to and/or incorporate any
20 combination of the features of previously described labels 110 through 610. Hence, only those features of label 710 not earlier mentioned will be discussed in detail.

Label 710 preferably includes means 734 for evidencing tampering of product prior to consumption thereof by an end user. According to a presently preferred construction, tamper evident means 734 comprise a fixed or disposable tear strip 736

contiguous with either the first, the first and second or , as shown, the second portion 714 of label 710 along perforation 738. Tear strip 736 may be of any length, but typically corresponds to the length of the circumference of C shown in Figure 12.

Figure 11 shows label 710 as it would appear when affixed to the
5 circumferential side wall of a substantially cylindrical product container P. To assure its attachment to the product container prior to removal, all or a portion of the tear strip 736 may be provided with a pressure sensitive or other suitable adhesive. When it is desired to access the contents of container P, the end user simply lifts a distal end flap 740 of the tear strip 736 and pulls the strip away from the remainder of the label 710 such that
10 the strip detaches from the label along perforation 738. Upon removal, the tear strip may then be discarded.

Once the tear strip 736 is removed, the product container cap or lid C is exposed thereby enabling the user to remove the cap and access the contents of the product container P. Should the end user discover however that, prior to purchase or
15 use, that tear strip 736 is missing or damaged, tamper evident means 734 alerts the user that consumption of the contents of product container P should be avoided.

Alternatively, distal end flap 740 may be omitted from tear strip 736. Tear strip 736 may be temporarily or permanently affixed to cap C and, instead of the end user tearing away tear strip 736, the end user may remove cap C by twisting or
20 pulling thereby breaking perforation 738 and alerting a subsequent user that the container had been previously opened. In this embodiment, tear strip 736 may either be removed from or remain attached to cap C.

Referring now to Figure 18, there is shown preferred embodiment of a product label 1800 constructed in accordance with the present invention. The label 1800 is essentially identical to the label shown in Figure 10, except that the label 1800 is adapted to be applied to irregularly shaped objects, particularly tapered objects. The label 1800 has a first portion 1812 with a top edge 1814 and a bottom edge 1816. The label 1800 also has a second portion 1817 with a top edge 1818 and a bottom edge 1820. To accommodate application to a tapered object having a top with a larger circumference than the bottom, the top edges 1814 and 1820 are longer than the corresponding bottom edges 1816 and 1818. In addition, the first portion 1812 may be oriented at an oblique angle relative to the second portion 1817. The relative length of the top and bottom edges and the angle between the first and second portions depend upon the shape and size of the article to which the label is to be applied. Generally, the greater the taper of the article, the greater the angle and the greater the difference between the length of the top and bottom edges, and *vice versa*. The specific lengths and angle are preferably selected so that the second portion 1817 substantially precisely overlaps the first portion 1812 when the label 1800 is wrapped more than 360° around an article. Alternatively, the specific lengths and angle may be selected so that the second portion 1817 only partially overlaps the first portion 1812 and partially contacts the container when the label 1800 is wrapped more than 360° around an article. Some or all of the edges may be curved to accommodate the difference in length between the top edges and the bottom edges. In Figure 18, the top edge 1820 of the second portion 1817 is curved. In another alternative embodiment, the second portion may comprise one or more sub-sections, wherein each sub-section is at an angle relative to the adjacent preceding sub-section and said angle is selected to fit the geometry of the object to which the label is to be applied.

As mentioned above, the label of this invention may be comprised of a flexible and printable substrate such as paper or plastic (such as, for example, polyvinyl chloride, polyethylene or polypropylene) sheet or web material. Although each label may be made individually, labels are preferably produced in larger quantities from rolls of such substrate such as sheet stock which can be continuously printed, coated with adhesive, affixed to release paper, and cut to produce multiple labels. One or more areas or surfaces of the label may also be coated with a lacquer or varnish in order to protect the label and/or printed inks from wear or other degradation. Also, as an alternative to the protective lacquer or varnish, an additional layer of protective material (e.g. a substantial transparent layer of plastic such as polyvinyl chloride, polyethylene or polypropylene) may be applied to select surfaces or areas of the label. The means by which the labels will be made will depend, in part, upon the features which are to be incorporated into such labels.

Referring to Figure 13, there is shown a schematic depicting a method for making the labels of this invention. It should be noted at the outset that the order in which the steps of the methods herein disclosed are carried out is not necessarily critical to successfully making the labels of this invention. As mentioned above, the labels are made from a flexible and printable substrate 800. Graphic or other inks 810 are printed by printing step 820 (e.g. by flexographic, rotogravure, silk screening or other printing methods) at predetermined locations on the top and/or bottom surfaces of substrate 800. For example, depending on the desired or necessary label configuration, inks 810 may be applied to: the top surface of first label portion 112, 212, 312, 412, 512, 612, or 712; the top surface of second label portion 114, 214, 314a, 414, 514, 614, or 714; and/or the bottom surface of second label portion 114, 214, 314, 414, 514, 614, or 714. Pressure sensitive adhesive 830 is applied by step 840 (e.g. hot melt or other adhesive means) to

predetermined locations on the bottom surface of substrate 800 so as to provide a means by which the label may be affixed to the desired object. For example, depending on the desired or necessary label configuration, pressure sensitive adhesive 830 may be applied to the bottom surface of the first label portion 112, 212, 312, 412, 512, 612, or 712.

5 Figure 14 depicts a method for making the labels of this invention which adds to the steps shown in Figure 13 optional step 860 for applying tack or releasable adhesive 850 to select locations on substrate 800 such that the second label portion may be selectively and repeatedly adhered to the first label portion. For example, depending on the desired or necessary label configuration, tack or releasable adhesive 850 may be
10 applied to the distal edge of the bottom surface of first label portion 112 (i.e. 118), 212, 312, 412, 512, 612, or 712.

 Figure 15 depicts a method for making the labels of this invention which adds to the steps shown in Figure 14 optional step 880 for applying a protective material 870 to select locations over substrate 800 and/or inks 810 in order to protect substrate
15 800 and/or inks 810 from wear or other degradation. For example, depending on the desired or necessary label configuration, protective material 870 (e.g. lacquer, varnish, PVC, or other substantially transparent protective material) may be applied to any surface. In addition, it should be noted that either adhesive 830 or 850 may be applied over protective material 870 provided that such application does not cause an adverse
20 chemical reaction.

 Figure 16 depicts a method for making the labels of this invention which adds additional optional steps to the steps shown in Figure 15. In this embodiment, substrate 800 is in the form of a web in order to facilitate the production of larger

quantities of labels. Specifically, in step 900 substrate web 800 is fed through a series of process steps. Each such step is represented schematically by a box in Figure 16.

As indicated above, the order in which the steps are carried out is not necessarily critical to the successful manufacture of the labels of this invention. With this in mind, inks 810 are printed on one or both sides of web 800 in printing step 820. Pressure sensitive adhesive 830 is applied to select areas of web 800 in application step 840. Releasable adhesive 850 is applied to select areas of web 800 in application step 860. A surface of web 800 bearing pressure sensitive adhesive 830 is applied to release paper 910 in application step 920 such that the resulting labels produced from this process may later be removed for application to container P. In application step 880, protective material 870 (e.g. lacquer, varnish (such as ultra violet varnish), PVC, or other substantially transparent protective material) is applied to select surfaces of web 800 which surfaces generally do not contain pressure sensitive adhesive 830. In die cutting step 940, substrate web 800 (along with any protective material 870) is die cut to form label blanks, perforations, and/or other openings (if any) in web 800. In stripping step 960, substrate waste 950 is removed from release paper 910 after die cutting step 940 thereby leaving finished label blanks releasably adhered to release paper 910 for later application to container P. Finally, in optional rewinding step 980, release paper 910 bearing die cut label blanks may be wound into rolls or other convenient form for later application of the resulting labels to container P or other objects by manual or automated means.

Figure 17 depicts another method for making the labels of this invention which method is similar to the method set forth in Figure 16. except that substrate web 800 is replaced with a pressure sensitive adhesive (PSA) material 805. PSA material

805 comprises substrate web 800 releasably adhered to release paper 910 by pressure sensitive adhesive 830 which adhesive 830 is typically coated on one side of web 800. In step 900 PSA material 805 is fed through a series of process steps. Each such step is represented schematically by a box in Figure 17. Again, the order in which the steps of this method are carried out is not necessarily critical to the successful manufacture of the labels of this invention. With this in mind, in step 990 release paper 910 is removed from PSA material 805 to expose pressure sensitive adhesive 830.

As discussed above, in certain embodiments of the labels of this invention, it is desirable to have certain portions of the label which are coated with pressure sensitive adhesive 830 (see e.g. portions 116, 216 and 316 of Figures 2 through 4 respectively and portions 416, 516, 616 and 716 of Figures 7 through 10 respectively) in certain areas which are intended to be indicia or ink bearing surfaces (see e.g. second portions 114, 214 and 314 of Figures 2 through 4 respectively and 414, 514, 614 and 714 of Figures 7 through 10 respectively). When PSA material 805 is provided with pressure sensitive adhesive 830 in areas where it is necessary or desirable to print indicia or inks 810, such areas must be "deadened" by either removing pressure sensitive adhesive 830 from web 800 or by applying a detackifying material such as a varnish, laminate or other material capable of providing a suitable surface for the printing of indicia or inks 810. This deadening process is particularly useful when it is necessary or desirable to print on the surface of web 800 which surface also bears pressure sensitive adhesive 830 (see e.g. surface 118 of Figure 5).

The deadening process (if any is required) is carried out in step 1000. With PSA material 805 prepared, web 800 may be printed with inks 810 on any surface of the label which is suitable for accepting inks 810. Such printed surfaces may include

both top and bottom surfaces of the label being produced, any surface not bearing pressure sensitive adhesive 830, or any surface which has been deadened in step 1000. Printing step 810 may comprise one or more steps wherein the top and bottom surfaces of the label are printed either simultaneously or in separate steps. In one embodiment of the invention, inks 810 are printed on the top surface of the PSA material 805, PSA material 805 is turned over, and inks 810 are printed on the bottom surface of PSA material 805.

In step 920, release paper 910 is reapplied to web 800 with pressure sensitive adhesive 830. Reapplication step 920 may occur at any time after printing step 810 is completed with respect to the surface of the label which also bears pressure sensitive adhesive 830.

As in the method depicted in Figure 16, application of protective material 870 takes place in step 880, die cutting of individual labels takes place in step 940, substrate waste 950 is stripped away in step 960, and the resulting web which bears the finished die cut label blanks is rewound in step 980.

Although the invention has been described in detail for the purpose of illustration, it is to be understood that such detail is solely for that purpose and that variations can be made therein by those skilled in the art without departing from the spirit and scope of the invention.

What is claimed is:

1. A unitary label suitable for attachment to an object having a circumference, said label comprising:
 - 5 first label portion;
a first adhesive means for affixing said first label portion about said circumference of said object;
 - a second label portion contiguous with said first label portion and operable to at least partly overlie said first label portion when said label is affixed
10 to said object, said first label portion and said second label portion having a combined length which is greater than said circumference of said object; and
means for facilitating separation of said second label portion from said first label portion when said label is affixed to said object.
- 15 2. The label of claim 1 wherein said means for facilitating separation comprises a protrusion provided on said second label portion.
3. The label of claim 1 wherein said means for facilitating separation comprises a notch provided in said first label portion.
20
4. The label of claim 1 wherein said means for facilitating separation comprise a protrusion provided on said second label portion and a notch provided in said first label portion.

5. The label of claim 1 wherein said first label portion has a length substantially corresponding to said circumference of said object.

6. The label of claim 1 further comprising second adhesive means for releasably attaching said second label portion to said first label portion when said label is affixed to said object.

7. The label of claim 6 wherein said second adhesive means is positioned adjacent said means for facilitating separation.

8. The label of claim 1 further comprising a first perforation disposed substantially at or near a boundary between said first and second portions.

9. The label of claim 8 further comprising second adhesive means for releasably attaching said second label portion to said first label portion when said label is affixed to said object.

10. The label of claim 9 wherein said second adhesive means is positioned adjacent said means for facilitating separation.

11. The label of claim 8 further comprising at least one additional perforation provided in said second label portion.

12. The label of claim 11 wherein said at least one additional perforation comprises two spaced-apart substantially parallel perforations defining a tear strip.

5 13. The label of claim 12 further comprising second adhesive means for releasably attaching said second label portion to said first label portion when said label is affixed to said object.

10 14. The label of claim 13 wherein said second adhesive means is positioned adjacent said means for facilitating separation.

15 15. A unitary label suitable for attachment to an object having a circumference, said label comprising:

a first label portion;

15 first adhesive means for affixing said first label portion about said circumference of said object;

20 a second label portion contiguous with said first label portion and operable to at least partly overlie said first label portion when said label is affixed to said object, said first label portion and said second label portion having a combined length which is greater than said circumference of said object; and

means for evidencing tampering of said object to which said label is affixed.

16. The label of claim 15 wherein said means for evidencing tampering comprise a tear strip contiguous with at least one of the first and second label portions.

5 17. The label of claim 16 wherein said tear strip is separable from at least one of said first or second label portions.

18. The label of claim 15 wherein said first label portion has a length substantially corresponding to said circumference of said object.

10 19. The label of claim 15 further comprising second adhesive means for releasably attaching said second label portion to said first label portion when said label is affixed to said object.

15 20. The label of claim 15 further comprising a first perforation disposed substantially at or near a boundary between said first and second portions.

20 21. The label of claim 20 further comprising second adhesive means for releasably attaching said second label portion to said first label portion when said label is affixed to said object.

22. The label of claim 15 further comprising means for facilitating separation of said second label portion from said first label portion when said label is affixed to said object.

25

23. The label of claim 22 wherein said means for facilitating separation comprises a protrusion provided on said second label portion.

24. The label of claim 22 wherein said means for facilitating separation comprises a notch provided in said first label portion.

25. The label of claim 22 wherein said means for facilitating separation comprise a protrusion provided on said second label portion and a notch provided in said first label portion.

10 26. A unitary label suitable for attachment to an object having a circumference, said label comprising:

a first label portion;

first adhesive means for affixing said first label portion about said circumference of said object; and

15 a second label portion contiguous with said first label portion and operable to at least partly overlie said first label portion by less than two-thirds of the length of said first label portion when said label is affixed to said object, said first label portion and said second label portion having a combined length which is greater than said circumference of said object.

20 27. A unitary label suitable for attachment to an object having a circumference, said label comprising:

a first label portion;

first adhesive means for affixing said first label portion about said circumference of said object; and

a second label portion contiguous with said first label portion and operable to at least partly overlie said first label portion by greater than two-thirds of the length of said first label portion when said label is affixed to said object, said first label portion and said second label portion having a combined length which is
5 greater than said circumference of said object.

28. A method for making a unitary label suitable for attachment to an object having a circumference, said method comprising the steps of:

forming said label having first and second contiguous label portions, wherein said first and second label portions each have top and bottom
10 surfaces, and wherein said first and second label portions have a combined length which is greater than the circumference of said object;

printing ink on said top surface of said first label portion and/or said top and/or bottom of said second label portion; and

applying pressure sensitive adhesive to said bottom surface of
15 said first label portion.

29. The method of claim 28, further comprising the step of applying releaseable adhesive to said bottom surface of said second label portion so as to allow said second label portion to be selectively and repeatedly adhered to said first label portion.

20 30. The method of claim 29, further comprising the step of applying protective material over first and/or second label portions not bearing said pressure sensitive or releaseable adhesive.

31. The method of claim 30, wherein said forming step comprises the steps of:

feeding a web comprising substrate material from which said label is formed;

applying said bottom surface of said first label portion bearing said pressure sensitive adhesive to said release paper; and

5 die cutting said first and second label portions to form a label blank.

32. The method of claim 31, further comprising the steps of:
stripping label substrate waste from said release paper; and
rewinding said release paper bearing said label blanks into a
10 roll or other convenient form for later application of said labels to said object.

33. A method for making a unitary label from a pressure sensitive adhesive material, said material comprising a substrate web releasably affixed to release paper by a pressure sensitive adhesive, said label being suitable for attachment to an object having a circumference, said method comprising the steps of:

15 removing said release paper from said pressure sensitive adhesive material;

preparing select surface areas of said substrate web for application of indicia or inks;

20 printing said inks or indicia on select surfaces of said substrate web; and

reapplying said release paper to said pressure sensitive adhesive material.

34. The method of claim 33 wherein said preparation step comprises deadening.

35. The method of claim 33 further comprising the step of applying protective material to said indicia or inks.

36. A unitary label suitable for attachment to an object having a circumference, said label comprising:

- 5 first label portion;
- a first adhesive means for affixing said first label portion about said circumference of said object;
- a second label portion contiguous with said first label portion and operable to at least partly overlie said first label portion when said label is affixed
- 10 to said object, said first label portion and said second label portion having a combined length which is greater than said circumference of said object; and
- a protective material affixed to said first and second label portions.

37. A unitary label suitable for attachment to an object having a circumference, said label comprising:

- 15 first label portion;
- a second label portion contiguous with said first label portion and operable to at least partly overlie said first label portion when said label is affixed to said object, said first label portion and said second label portion having a combined
- 20 length which is greater than said circumference of said object;

wherein the label has top and bottom edges and the top edge has a different length than the bottom edge and the first portion is oriented at an oblique angle relative to the second portion.

38. The label of claim 37 where at least a portion of the longer edge is

25 curved.

FIG. 1
(Prior Art)

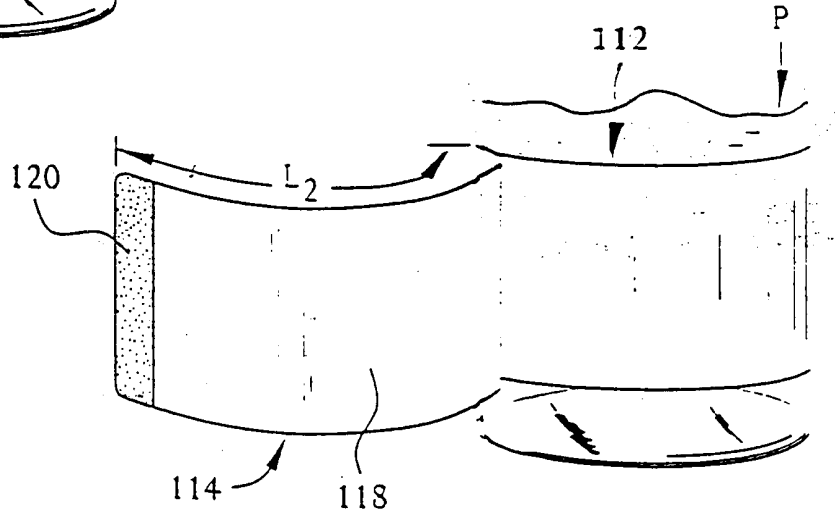
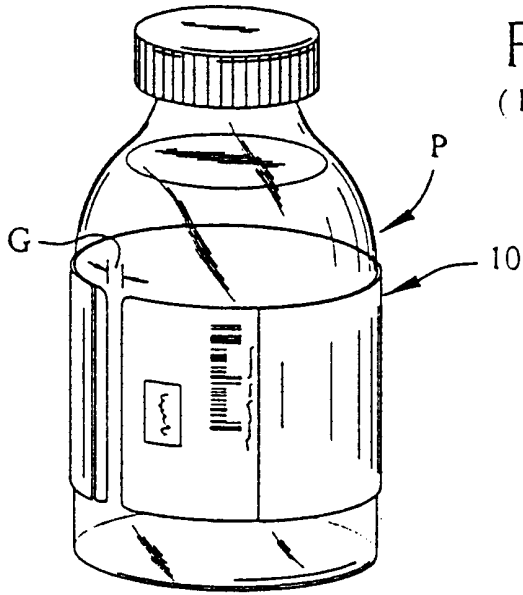

FIG. 5

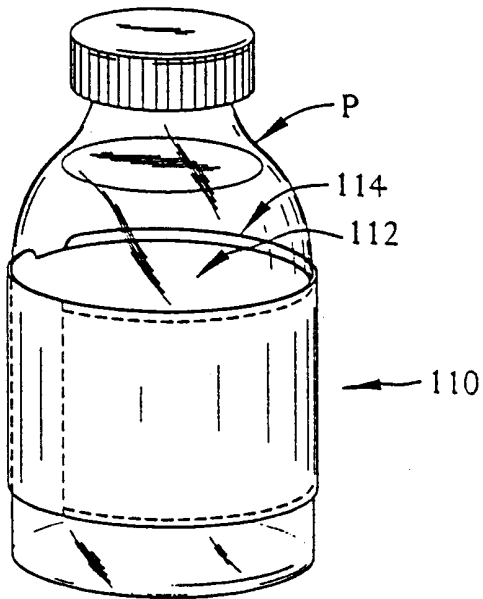

FIG. 6

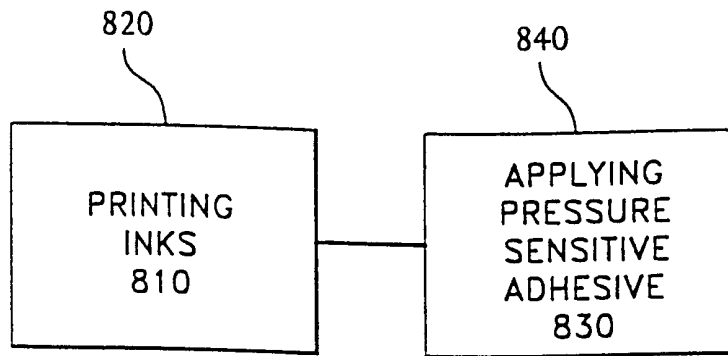

FIG. 13

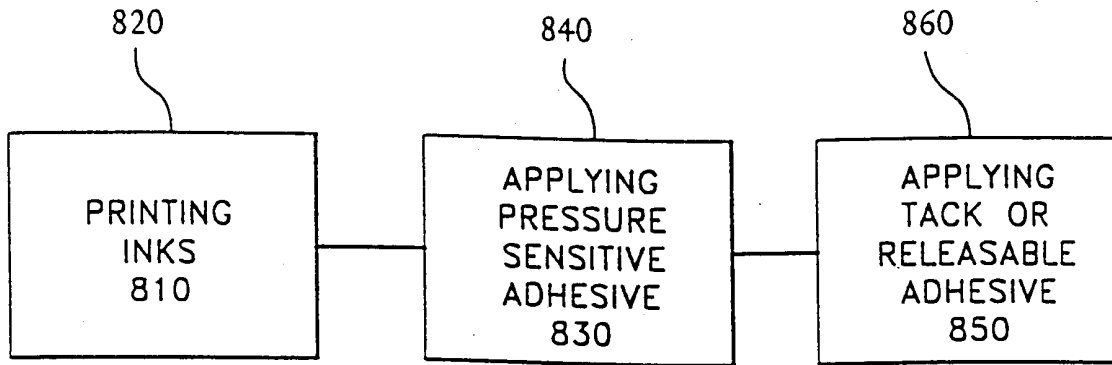

FIG. 14

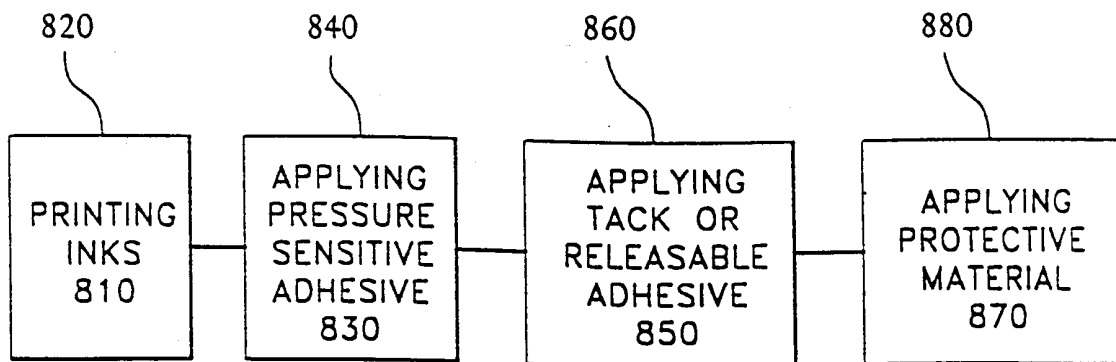

FIG. 15

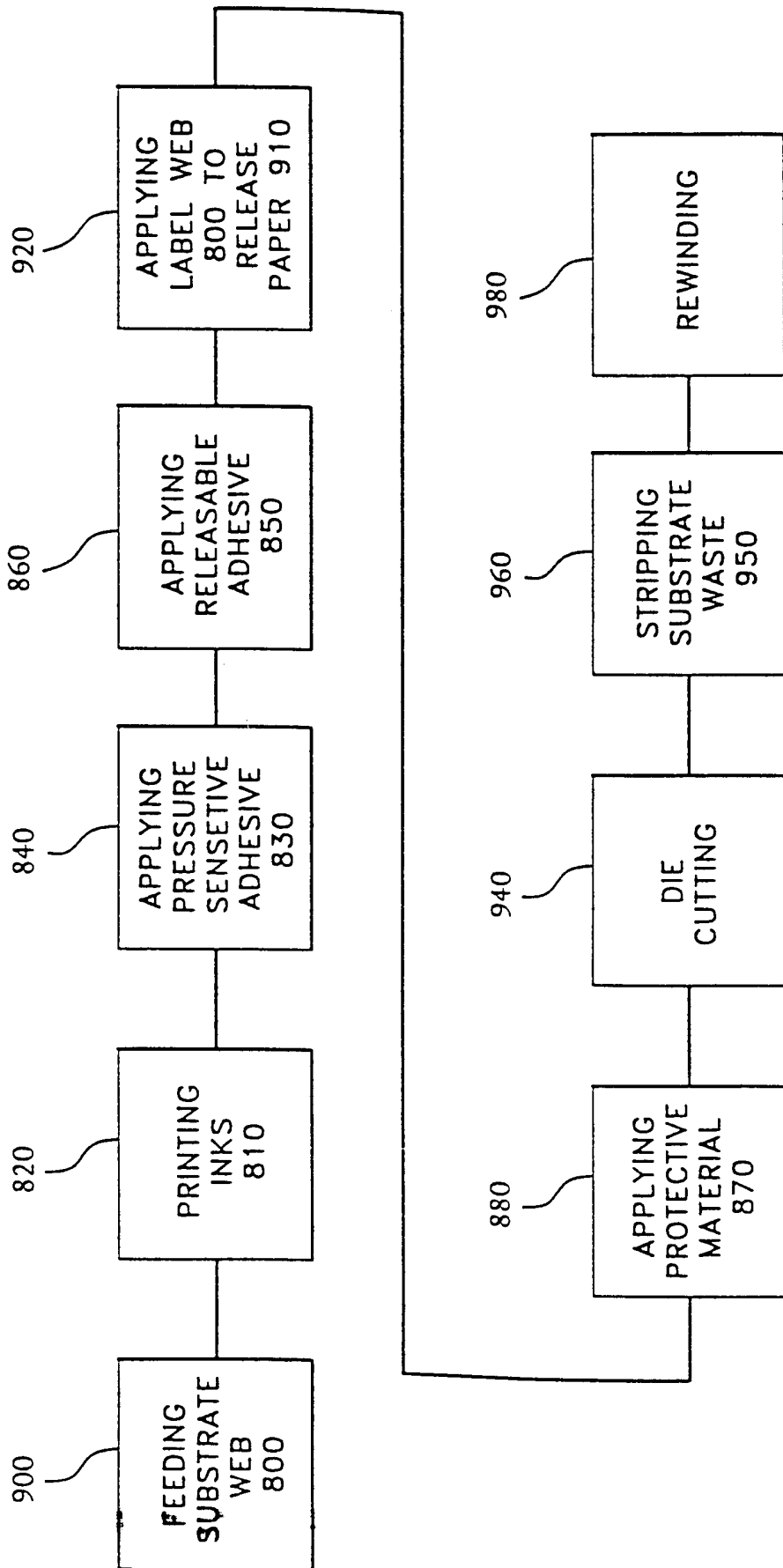
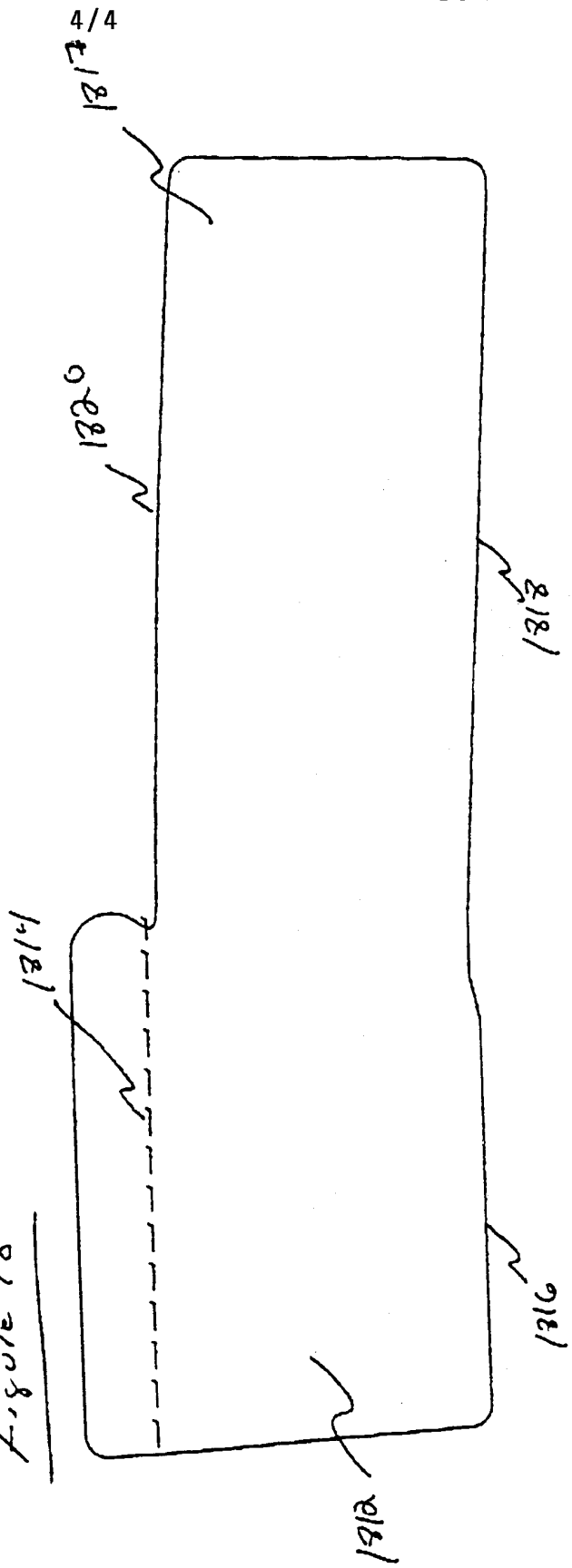

FIG. 16

Figure 18



4/4

INTERNATIONAL SEARCH REPORT

International application No.
PCT/US00/26335

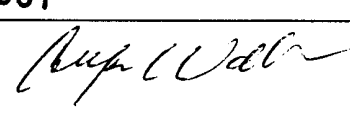
<p>A. CLASSIFICATION OF SUBJECT MATTER IPC(7) : B32B 7/06; G09F 3/00 US CL : Please See Extra Sheet. According to International Patent Classification (IPC) or to both national classification and IPC</p>		
<p>B. FIELDS SEARCHED Minimum documentation searched (classification system followed by classification symbols) U.S. : 428/40.1, 42.1, 42.2, 43, 192, 355, 914; 281/2, 5; 283/81, 101, 105</p>		
<p>Documentation searched other than minimum documentation to the extent that such documents are included in the fields searched none</p>		
<p>Electronic data base consulted during the international search (name of data base and, where practicable, search terms used) none</p>		
<p>C. DOCUMENTS CONSIDERED TO BE RELEVANT</p>		
Category*	Citation of document, with indication, where appropriate, of the relevant passages	Relevant to claim No.
X, P ---- Y	US 5,989,667 A (TAYEBI) 23 November 1999, see abstract, drawings.	1-14 ----- 15-38
Y	US 5,403,636 A (CRUM) 04 April 1995, See abstract; figures 1 and 2.	15-38
<p><input type="checkbox"/> Further documents are listed in the continuation of Box C. <input type="checkbox"/> See patent family annex.</p>		
"A"	document defining the general state of the art which is not considered to be of particular relevance	"T" later document published after the international filing date or priority date and not in conflict with the application but cited to understand the principle or theory underlying the invention
"E"	earlier document published on or after the international filing date	"X" document of particular relevance, the claimed invention cannot be considered novel or cannot be considered to involve an inventive step when the document is taken alone
"L"	document which may throw doubts on priority claim(s) or which is cited to establish the publication date of another citation or other special reason (as specified)	"Y" document of particular relevance; the claimed invention cannot be considered to involve an inventive step when the document is combined with one or more other such documents, such combination being obvious to a person skilled in the art
"O"	document referring to an oral disclosure, use, exhibition or other means	"&" document member of the same patent family
"P"	document published prior to the international filing date but later than the priority date claimed	
<p>Date of the actual completion of the international search 14 DECEMBER 2000</p>		<p>Date of mailing of the international search report 12 JAN 2001</p>
<p>Name and mailing address of the ISA/US Commissioner of Patents and Trademarks Box PCT Washington, D.C. 20231 Facsimile No. (703) 305-3230</p>		<p>Authorized officer  NASSER AHMAD Telephone No. (703) 308-0661</p>

INTERNATIONAL SEARCH REPORT

International application No.
PCT/US00/26335

A. CLASSIFICATION OF SUBJECT MATTER:

US CL :

428/40.1, 42.1, 42.2, 43, 192, 355, 914; 281/2, 5; 283/81, 101, 105; 156/247, 277, 289, 295