



(19) **United States**

(12) **Patent Application Publication**
Steinke

(10) **Pub. No.: US 2019/0358461 A1**

(43) **Pub. Date: Nov. 28, 2019**

(54) **SYSTEMS AND METHODS FOR SELECTING STIMULATION PARAMETERS BY TARGETING AND STEERING**

(52) **U.S. Cl.**
CPC *A61N 1/37247* (2013.01); *A61N 1/37241* (2013.01); *A61N 1/36185* (2013.01); *A61N 1/3605* (2013.01); *A61N 1/0551* (2013.01)

(71) Applicant: **Boston Scientific Neuromodulation Corporation, Valencia, CA (US)**

(72) Inventor: **G. Karl Steinke, Valencia, CA (US)**

(21) Appl. No.: **16/537,210**

(22) Filed: **Aug. 9, 2019**

Related U.S. Application Data

(62) Division of application No. 15/194,380, filed on Jun. 27, 2016, now Pat. No. 10,441,800.

(60) Provisional application No. 62/186,172, filed on Jun. 29, 2015.

Publication Classification

(51) **Int. Cl.**
A61N 1/372 (2006.01)
A61N 1/05 (2006.01)
A61N 1/36 (2006.01)

(57) **ABSTRACT**

Methods and systems for selecting stimulation parameters using targeting and steering techniques are presented. For example, a method or system (via actions performed by a processor) can include receiving a name of an anatomical or physiological target or a name of a disease or disorder; receiving a clinical goal; and using at least 1) the anatomical or physiological target or disease or disorder and 2) the clinical goal, selecting a set of stimulation parameters. Another method or system (via actions performed by its processor) can include receiving a first set of stimulation parameters; receiving a command to alter the first set of stimulation parameters that does not include, or is not composed exclusively of, a numerical value for any of the stimulation parameters; and modifying the first set of stimulation parameters to create a second set of stimulation parameters based on the command.

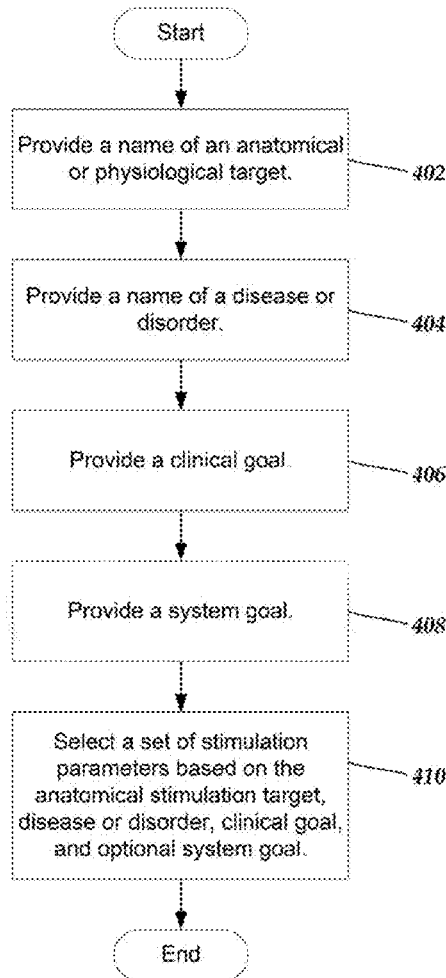

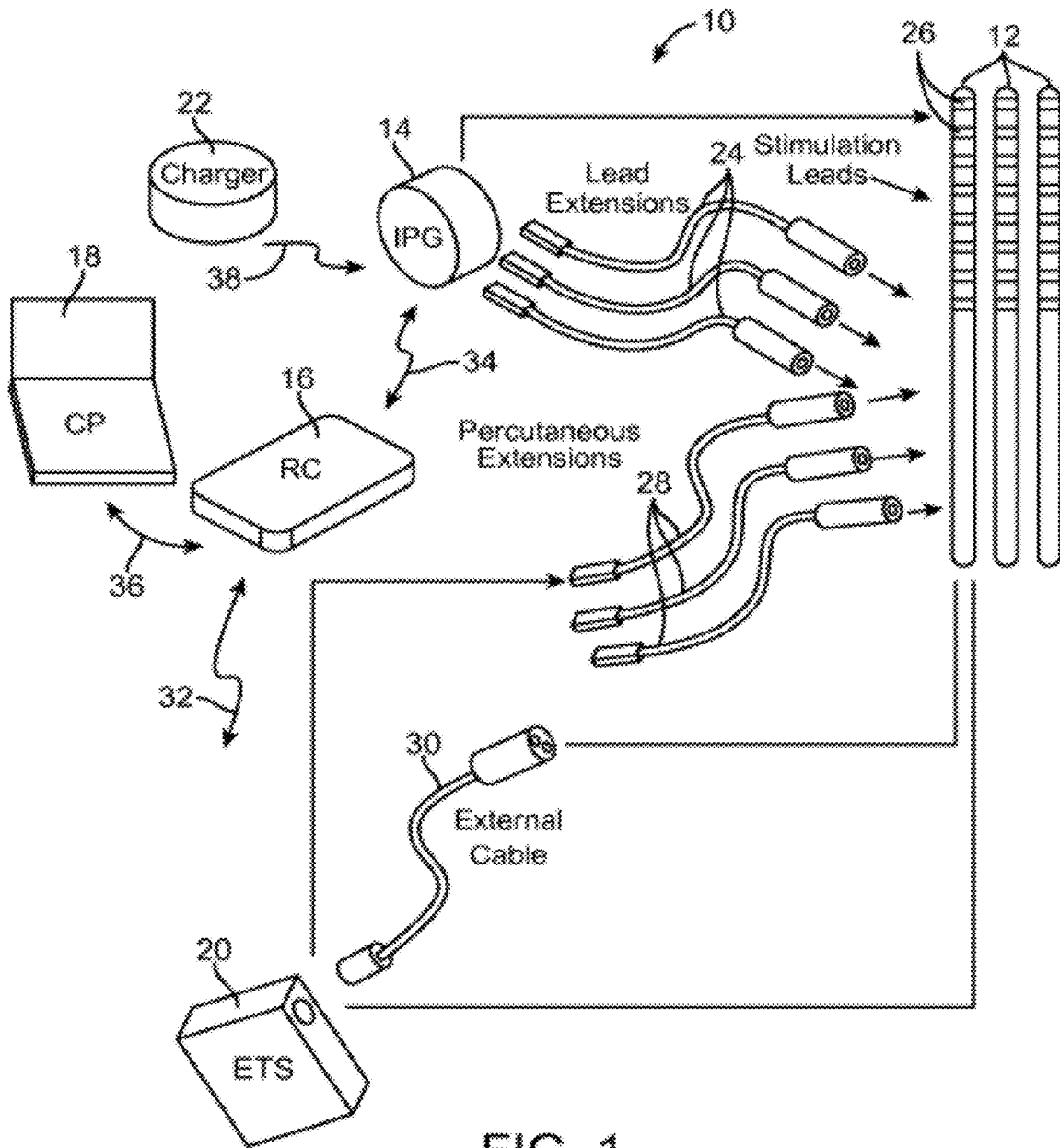
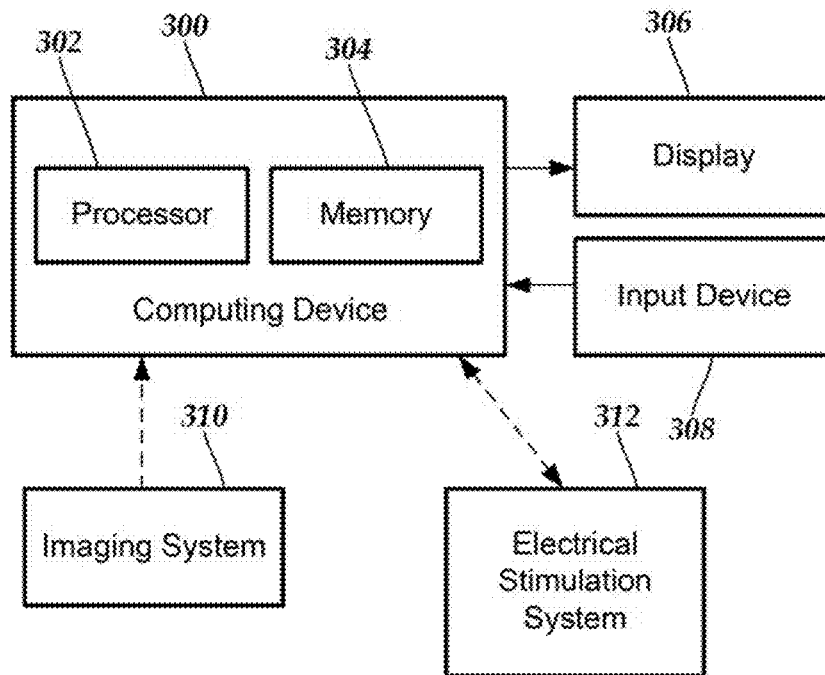
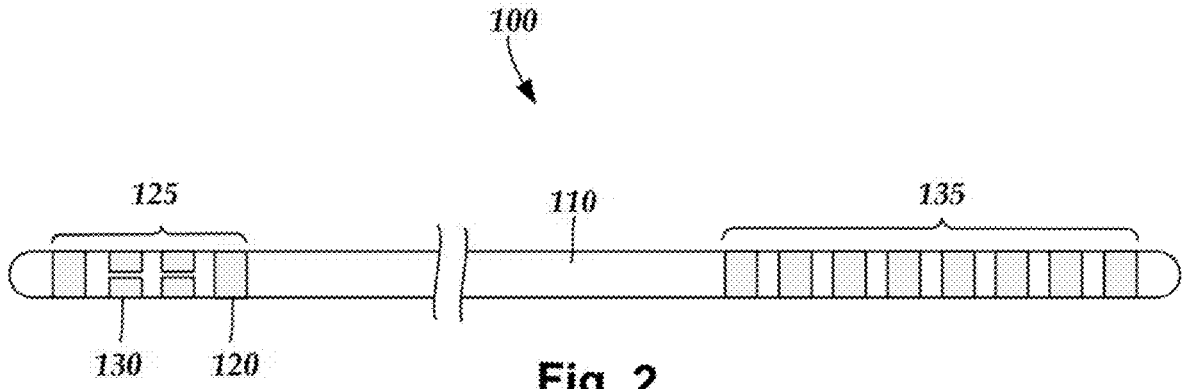

FIG. 1



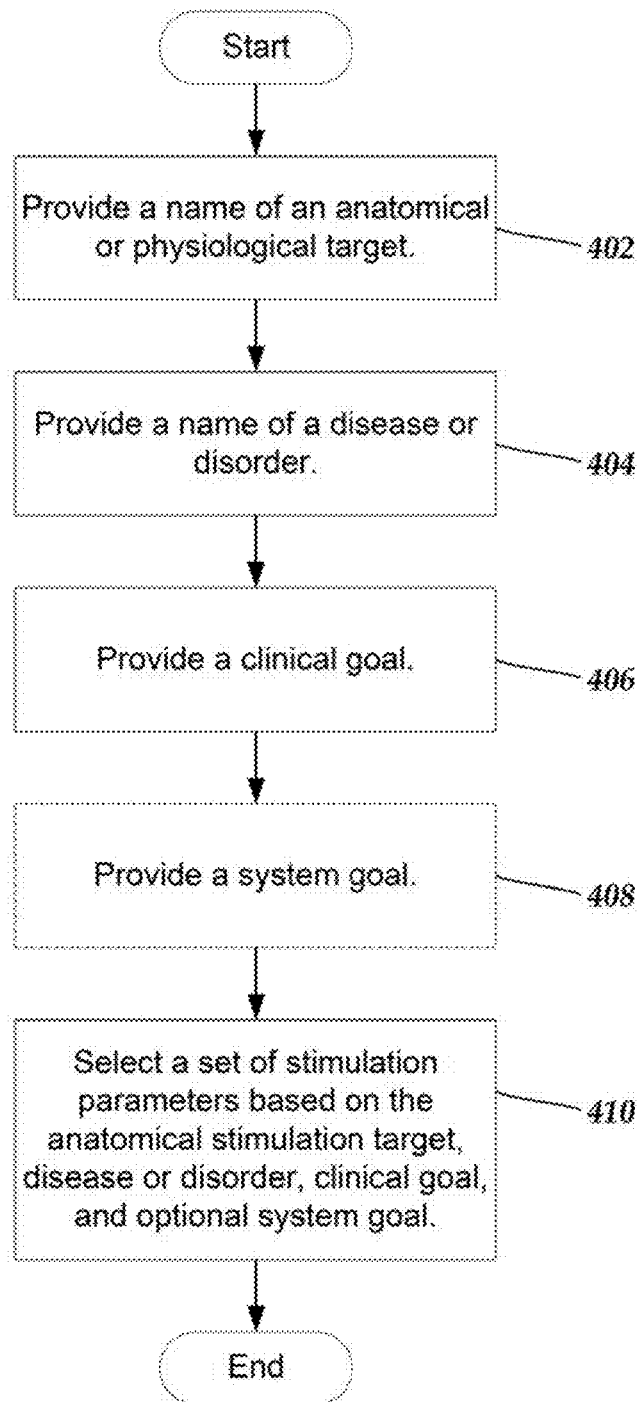

Fig. 4

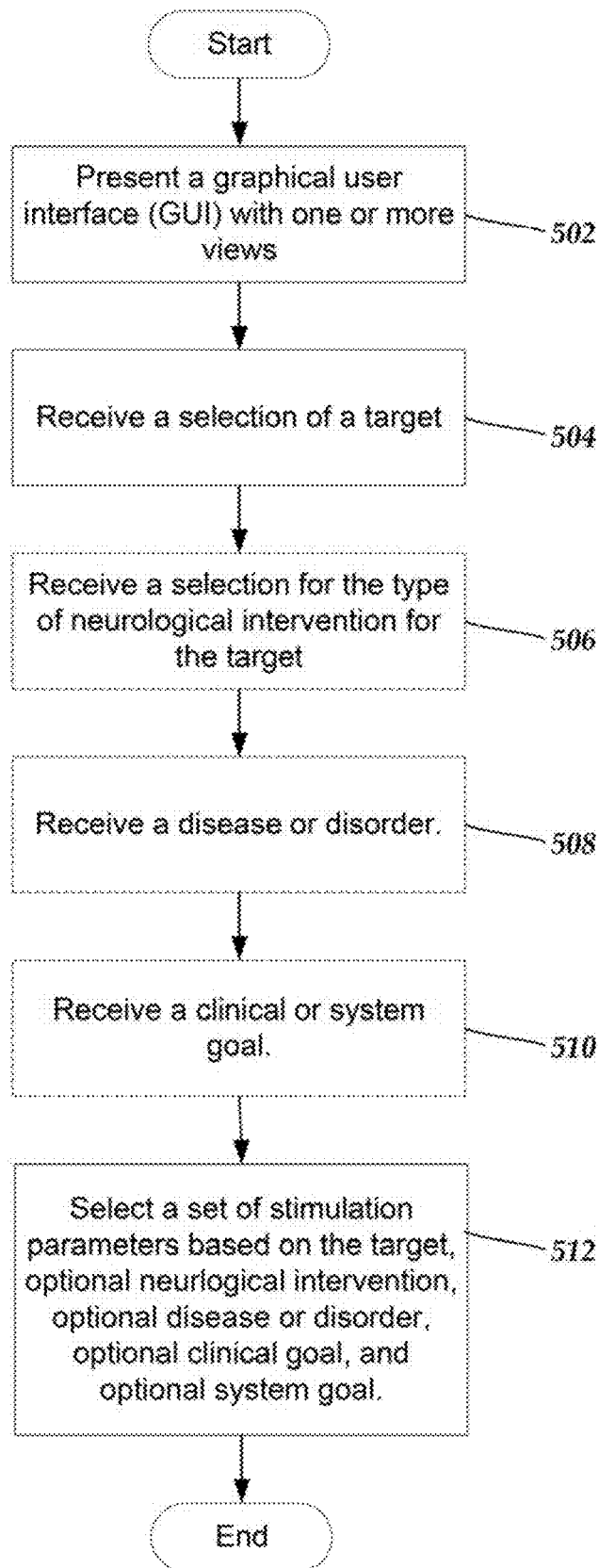

Fig. 5

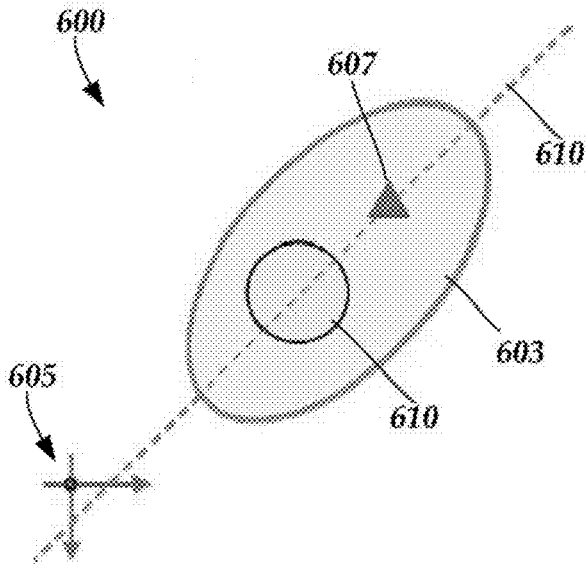

Fig. 6A

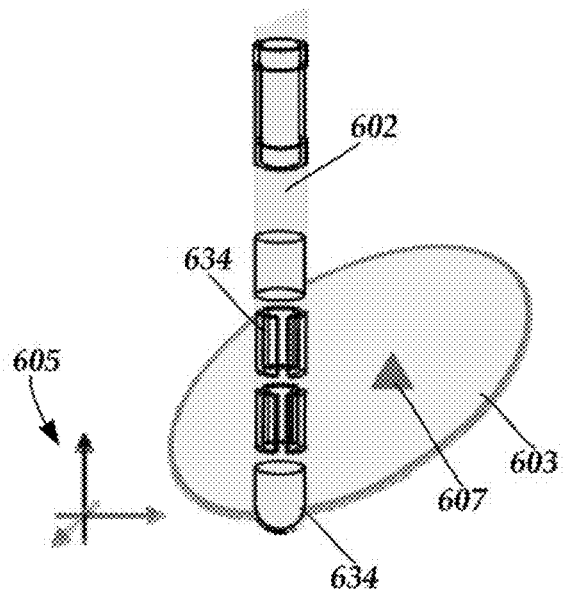

Fig. 6B

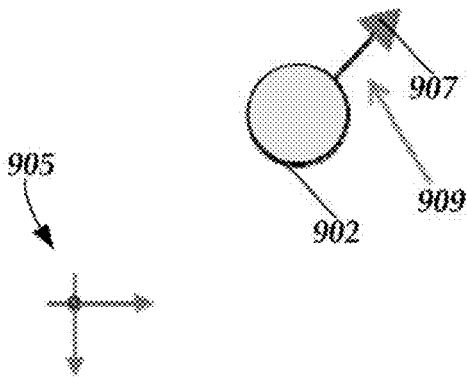

Fig. 9A

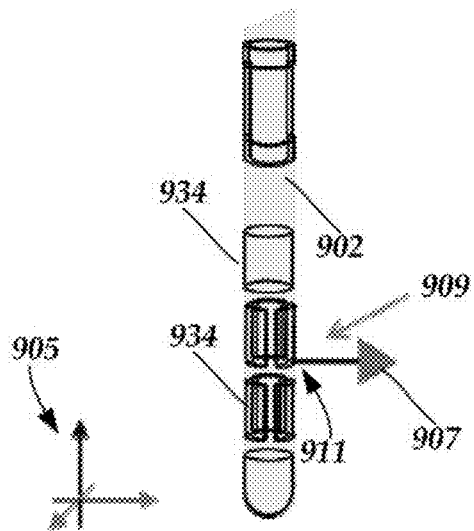

Fig. 9B

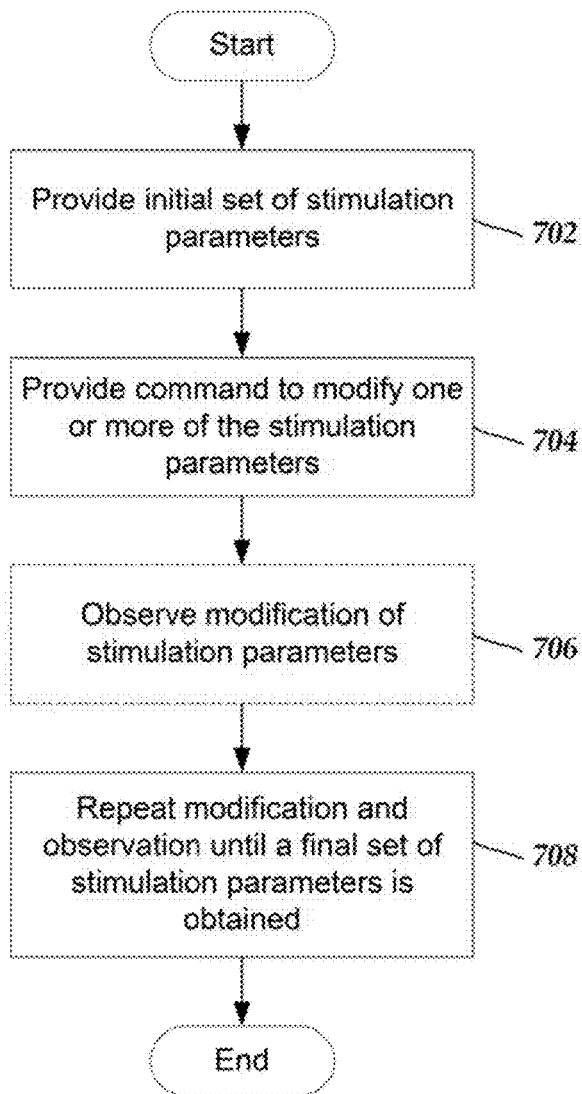

Fig. 7

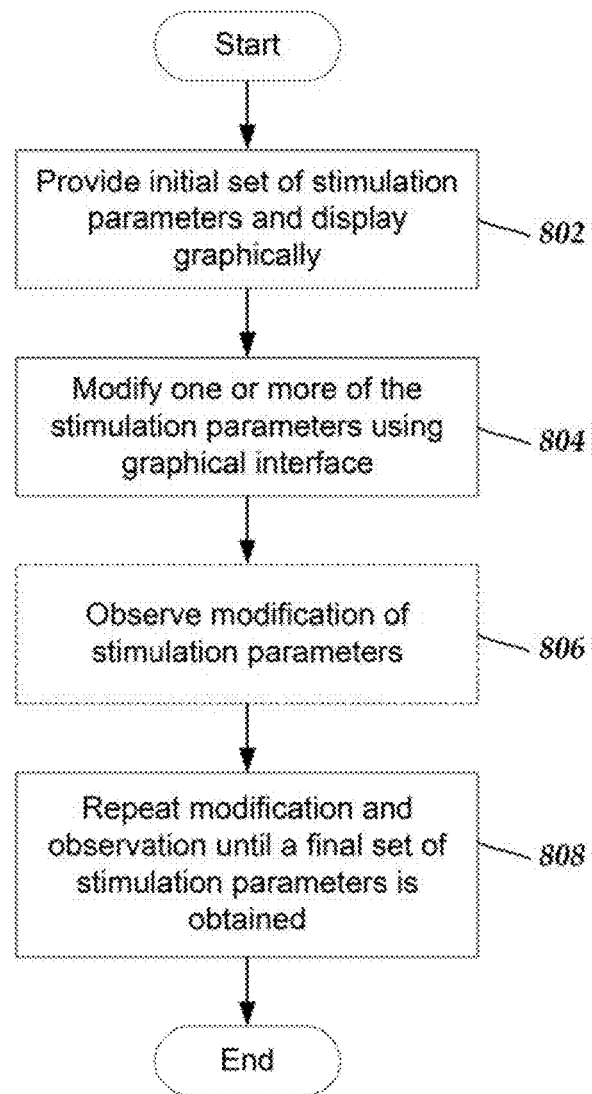

Fig. 8

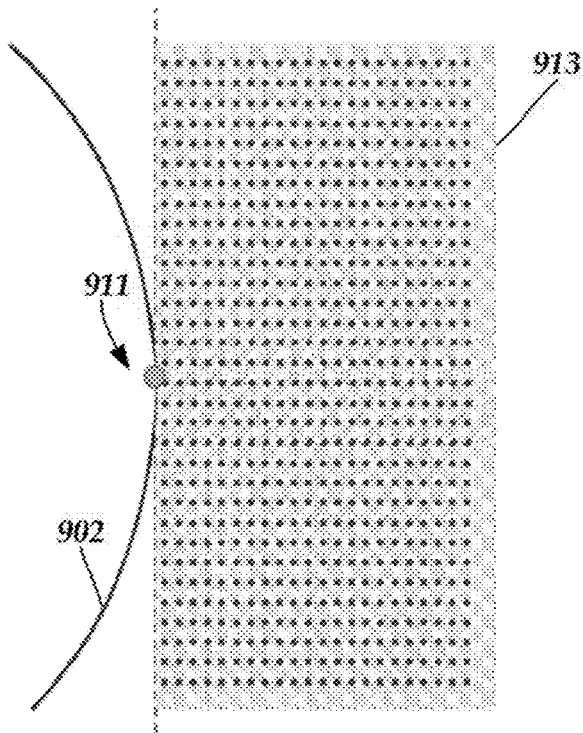

Fig. 10

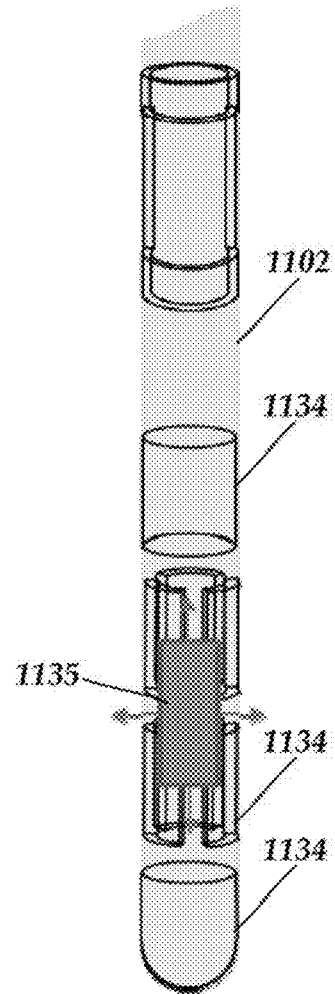

Fig. 11

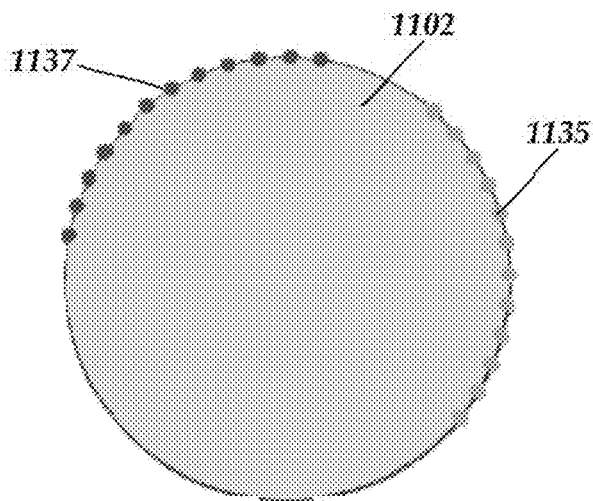

Fig. 12

SYSTEMS AND METHODS FOR SELECTING STIMULATION PARAMETERS BY TARGETING AND STEERING

CROSS-REFERENCE TO RELATED APPLICATIONS

[0001] This application is a divisional of U.S. patent application Ser. No. 15/194,380, filed Jun. 27, 2017, which claims the benefit under 35 U.S.C. § 119(e) of U.S. Provisional Patent Application Ser. No. 62/186,172, filed Jun. 29, 2015, both of which are incorporated herein by reference.

FIELD

[0002] The present invention is directed to the area of implantable electrical stimulation systems and methods of making and using the systems. The present invention is also directed to systems and methods for selecting stimulation parameters using targeting and steering mechanisms.

BACKGROUND

[0003] Implantable electrical stimulation systems have proven therapeutic in a variety of diseases and disorders. For example, spinal cord stimulation systems have been used as a therapeutic modality for the treatment of chronic pain syndromes. Peripheral nerve stimulation has been used to treat chronic pain syndrome and incontinence, with a number of other applications under investigation. Functional electrical stimulation systems have been applied to restore some functionality to paralyzed extremities in spinal cord injury patients. Stimulation of the brain, such as deep brain stimulation, can be used to treat a variety of diseases or disorders.

[0004] Stimulators have been developed to provide therapy for a variety of treatments. A stimulator can include a control module (with a pulse generator), one or more leads, and an array of stimulator electrodes on each lead. The stimulator electrodes are in contact with or near the nerves, muscles, or other tissue to be stimulated. The pulse generator in the control module generates electrical pulses that are delivered by the electrodes to body tissue.

BRIEF SUMMARY

[0005] One embodiment is a system for identifying a set of stimulation parameters, the system includes a computer processor configured and arranged to perform the following actions: receiving a name of an anatomical or physiological target or a name of a disease or disorder; receiving a clinical goal; and using at least 1) the anatomical or physiological target or disease or disorder and 2) the clinical goal, selecting a set of stimulation parameters.

[0006] Another embodiment is a non-transitory computer-readable medium having processor-executable instructions for identifying a set of stimulation parameters, the processor-executable instructions when installed onto a device enable the device to perform actions, including: receiving a name of an anatomical or physiological target or a name of a disease or disorder; receiving a clinical goal; and using at least 1) the anatomical or physiological target or disease or disorder and 2) the clinical goal, selecting a set of stimulation parameters.

[0007] Yet another embodiment is a method for identifying a set of stimulation parameters. The method includes receiving a name of an anatomical or physiological target or

a name of a disease or disorder; receiving a clinical goal; and using at least 1) the anatomical or physiological target or disease or disorder and 2) the clinical goal, selecting a set of stimulation parameters.

[0008] In at least some embodiments, the system, non-transitory computer-readable medium, or method described above further includes receiving a system goal, wherein selecting the set of stimulation parameters includes using the system goal to select the set of stimulation parameters. In at least some embodiments of the system, non-transitory computer-readable medium, or method described above, the system goal refers to one or more components of an electrical stimulation system or to one or more stimulation parameters and also refers to an objective related to the one or more components or stimulation parameters.

[0009] In at least some embodiments of the system, non-transitory computer-readable medium, or method described above, the clinical goal refers to the disease or disorder or to a symptom of the disease or disorder or to an effect or side effect associated with the disease or disorder or with electrical stimulation of the anatomical or physiological target.

[0010] In at least some embodiments, the system, non-transitory computer-readable medium, or method described above further includes receiving a user modification of at least one of the stimulation parameters. In at least some embodiments of the system, non-transitory computer-readable medium, or method described above, selecting the set of stimulation parameters further includes using previous stimulation instances or estimated stimulation instances to select the set of stimulation parameters. In at least some embodiments, the system, non-transitory computer-readable medium, or method described above further includes displaying an estimated stimulation region based on the selected set of stimulation parameters.

[0011] A further embodiment is a system for identifying a set of stimulation parameters, the system includes a computer processor configured and arranged to perform the following actions: providing a model of a lead including a plurality of electrodes, wherein the plurality of electrodes includes a plurality of segmented electrodes forming at least one set of segmented electrodes, wherein each set of segmented electrodes includes a plurality of the segmented electrodes disposed around a circumference of the lead at a same longitudinal position along the lead; receiving a selection of a target point external to the lead; projecting the target point onto a surface of the lead to identify a virtual electrode; and selecting a set of stimulation parameters for at least one of the electrodes to approximate an electrical field generated from the virtual electrode.

[0012] Another embodiment is a non-transitory computer-readable medium having processor-executable instructions for identifying a set of stimulation parameters, the processor-executable instructions when installed onto a device enable the device to perform actions, including: providing a model of a lead including a plurality of electrodes, wherein the plurality of electrodes includes a plurality of segmented electrodes forming at least one set of segmented electrodes, wherein each set of segmented electrodes includes a plurality of the segmented electrodes disposed around a circumference of the lead at a same longitudinal position along the lead; receiving a selection of a target point external to the lead; projecting the target point onto a surface of the lead to identify a virtual electrode; and selecting a set of stimulation

parameters for at least one of the electrodes to approximate an electrical field generated from the virtual electrode.

[0013] Yet another embodiment is a method for identifying a set of stimulation parameters. The method includes providing a model of a lead including a plurality of electrodes, wherein the plurality of electrodes includes a plurality of segmented electrodes forming at least one set of segmented electrodes, wherein each set of segmented electrodes includes a plurality of the segmented electrodes disposed around a circumference of the lead at a same longitudinal position along the lead; receiving a selection of a target point external to the lead; projecting the target point onto a surface of the lead to identify a virtual electrode; and selecting a set of stimulation parameters for at least one of the electrodes to approximate an electrical field generated from the virtual electrode.

[0014] In at least some embodiments of the system, non-transitory computer-readable medium, or method described above, projecting the target point includes projecting the target point onto a nearest point of the surface of the lead to identify the virtual electrode. In at least some embodiments, the system, non-transitory computer-readable medium, or method described above further includes calculating the electrical field in a region that does not overlap with the lead and is bounded by a plane tangent to the lead at the virtual electrode. In at least some embodiments of the system, non-transitory computer-readable medium, or method described above, the electrical field is a scalar potential field, a vector field, or a field of Hamiltonians of a divergence of an electrical field.

[0015] In at least some embodiments, the system, non-transitory computer-readable medium, or method described above further includes receiving a user modification of at least one of the stimulation parameters. In at least some embodiments, the system, non-transitory computer-readable medium, or method described above, further includes defining at least one guarding electrode adjacent the virtual electrode. In at least some embodiments of the system, non-transitory computer-readable medium, or method described above, defining at least one guarding electrode includes defining two guarding electrodes circumferentially disposed on opposite sides of the virtual electrode.

[0016] A further embodiment is a system for identifying a set of stimulation parameters, the system includes a computer processor configured and arranged to perform the following actions: receiving a first set of stimulation parameters; receiving a command to alter the first set of stimulation parameters, wherein the command does not include, or is not composed exclusively of, a numerical value for any of the stimulation parameters; and modifying the first set of stimulation parameters to create a second set of stimulation parameters based on the command.

[0017] Another embodiment is a non-transitory computer-readable medium having processor-executable instructions for identifying a set of stimulation parameters, the processor-executable instructions when installed onto a device enable the device to perform actions, including: receiving a first set of stimulation parameters; receiving a command to alter the first set of stimulation parameters, wherein the command does not include, or is not composed exclusively of, a numerical value for any of the stimulation parameters; and modifying the first set of stimulation parameters to create a second set of stimulation parameters based on the command.

[0018] Yet another embodiment is a method for identifying a set of stimulation parameters. The method includes receiving a first set of stimulation parameters; receiving a command to alter the first set of stimulation parameters, wherein the command does not include, or is not composed exclusively of, a numerical value for any of the stimulation parameters; and modifying the first set of stimulation parameters to create a second set of stimulation parameters based on the command.

[0019] In at least some embodiments, the system, non-transitory computer-readable medium, or method described above further includes displaying an estimated stimulation region based on the first set of stimulation parameters. In at least some embodiments, the system, non-transitory computer-readable medium, or method described above further includes, upon modification of the first set of stimulation parameters to create the second set of stimulation parameters, modifying the display to display an estimated stimulation region based on the second set of stimulation parameters.

[0020] In at least some embodiments, the system, non-transitory computer-readable medium, or method described above further includes receiving a user modification of at least one of the stimulation parameters of the second set of stimulation parameters. In at least some embodiments, the system, non-transitory computer-readable medium, or method described above further includes repeating the actions with the second set of stimulation parameters becoming the first set of stimulation parameters for the repeated actions. In at least some embodiments, the system, non-transitory computer-readable medium, or method described above further includes sending the second set of stimulation parameters to an implantable pulse generator of an electrical stimulation system.

BRIEF DESCRIPTION OF THE DRAWINGS

[0021] Non-limiting and non-exhaustive embodiments of the present invention are described with reference to the following drawings. In the drawings, like reference numerals refer to like parts throughout the various figures unless otherwise specified.

[0022] For a better understanding of the present invention, reference will be made to the following Detailed Description, which is to be read in association with the accompanying drawings, wherein:

[0023] FIG. 1 is a schematic view of one embodiment of an electrical stimulation system, according to the invention;

[0024] FIG. 2 is a schematic side view of one embodiment of an electrical stimulation lead, according to the invention;

[0025] FIG. 3 is a schematic block diagram of one embodiment of a system for determining stimulation parameters, according to the invention;

[0026] FIG. 4 is a flowchart of one embodiment of a method of determining stimulation parameters, according to the invention;

[0027] FIG. 5 is a flowchart of a second embodiment of a method of determining stimulation parameters, according to the invention;

[0028] FIG. 6A is a diagrammatic illustration of one embodiment of a method of selecting a stimulation target, according to the invention;

[0029] FIG. 6B is a diagrammatic illustration of the embodiment of FIG. 6A rotated to view along a plane including line 610, according to the invention;

[0030] FIG. 7 is a flowchart of a third embodiment of a method of determining stimulation parameters, according to the invention;

[0031] FIG. 8 is a flowchart of a fourth embodiment of a method of determining stimulation parameters, according to the invention;

[0032] FIG. 9A is a diagrammatic illustration of one embodiment of a method of selecting a point source, according to the invention;

[0033] FIG. 9B is a diagrammatic illustration of the embodiment of FIG. 9A taken from an orthogonal position, according to the invention;

[0034] FIG. 10 is a diagrammatic illustration of an electrical field calculated for the point source of FIG. 9A, according to the invention;

[0035] FIG. 11 is a diagrammatic illustration of a portion of a model of a lead and a virtual electrode defined for the lead, according to the invention; and

[0036] FIG. 12 is a diagrammatic illustration of a cross-section of the lead of FIG. 11 illustrating the virtual electrode and a guarding electrode, according to the invention.

DETAILED DESCRIPTION

[0037] The present invention is directed to the area of implantable electrical stimulation systems and methods of making and using the systems. The present invention is also directed to systems and methods for selecting stimulation parameters using targeting and steering mechanisms.

[0038] Suitable implantable electrical stimulation systems include, but are not limited to, a least one lead with one or more electrodes disposed on a distal end of the lead and one or more terminals disposed on one or more proximal ends of the lead. Leads include, for example, percutaneous leads, paddle leads, cuff leads, or any other arrangement of electrodes on a lead. Examples of electrical stimulation systems with leads are found in, for example, U.S. Pat. Nos. 6,181,969; 6,516,227; 6,609,029; 6,609,032; 6,741,892; 7,244,150; 7,450,997; 7,672,734; 7,761,165; 7,783,359; 7,792,590; 7,809,446; 7,949,395; 7,974,706; 8,175,710; 8,224,450; 8,271,094; 8,295,944; 8,364,278; 8,391,985; and 8,688,235; and U.S. Patent Applications Publication Nos. 2007/0150036; 2009/0187222; 2009/0276021; 2010/0076535; 2010/0268298; 2011/0005069; 2011/0004267; 2011/0078900; 2011/0130817; 2011/0130818; 2011/0238129; 2011/0313500; 2012/0016378; 2012/0046710; 2012/0071949; 2012/0165911; 2012/0197375; 2012/0203316; 2012/0203320; 2012/0203321; 2012/0316615; 2013/0105071; and 2013/0197602, all of which are incorporated by reference. In the discussion below, a percutaneous lead will be exemplified, but it will be understood that the methods and systems described herein are also applicable to paddle leads and other leads.

[0039] A percutaneous lead for electrical stimulation (for example, deep brain or spinal cord stimulation) includes stimulation electrodes that can be ring electrodes, segmented electrodes that extend only partially around the circumference of the lead, or any other type of electrode, or any combination thereof. The segmented electrodes can be provided in sets of electrodes, with each set having electrodes circumferentially distributed about the lead at a particular longitudinal position. For illustrative purposes, the leads are described herein relative to use for deep brain stimulation, but it will be understood that any of the leads can be used for applications other than deep brain stimulation, including

spinal cord stimulation, peripheral nerve stimulation, or stimulation of other nerves, muscles, and tissues.

[0040] Turning to FIG. 1, one embodiment of an electrical stimulation system 10 includes one or more stimulation leads 12 and an implantable pulse generator (IPG) 14. The system 10 can also include one or more of an external remote control (RC) 16, a clinician's programmer (CP) 18, an external trial stimulator (ETS) 20, or an external charger 22.

[0041] The IPG 14 is physically connected, optionally via one or more lead extensions 24, to the stimulation lead(s) 12. Each lead carries multiple electrodes 26 arranged in an array. The IPG 14 includes pulse generation circuitry that delivers electrical stimulation energy in the form of, for example, a pulsed electrical waveform (i.e., a temporal series of electrical pulses) to the electrode array 26 in accordance with a set of stimulation parameters. The implantable pulse generator can be implanted into a patient's body, for example, below the patient's clavicle area or within the patient's buttocks or abdominal cavity. The implantable pulse generator can have eight stimulation channels which may be independently programmable to control the magnitude of the current stimulus from each channel. In some embodiments, the implantable pulse generator can have more or fewer than eight stimulation channels (e.g., 4-, 6-, 16-, 32-, or more stimulation channels). The implantable pulse generator can have one, two, three, four, or more connector ports, for receiving the terminals of the leads.

[0042] The ETS 20 may also be physically connected, optionally via the percutaneous lead extensions 28 and external cable 30, to the stimulation leads 12. The ETS 20, which may have similar pulse generation circuitry as the IPG 14, also delivers electrical stimulation energy in the form of, for example, a pulsed electrical waveform to the electrode array 26 in accordance with a set of stimulation parameters. One difference between the ETS 20 and the IPG 14 is that the ETS 20 is often a non-implantable device that is used on a trial basis after the neurostimulation leads 12 have been implanted and prior to implantation of the IPG 14, to test the responsiveness of the stimulation that is to be provided. Any functions described herein with respect to the IPG 14 can likewise be performed with respect to the ETS 20.

[0043] The RC 16 may be used to telemetrically communicate with or control the IPG 14 or ETS 20 via a uni- or bi-directional wireless communications link 32. Once the IPG 14 and neurostimulation leads 12 are implanted, the RC 16 may be used to telemetrically communicate with or control the IPG 14 via a uni- or bi-directional communications link 34. Such communication or control allows the IPG 14 to be turned on or off and to be programmed with different stimulation parameter sets. The IPG 14 may also be operated to modify the programmed stimulation parameters to actively control the characteristics of the electrical stimulation energy output by the IPG 14. The CP 18 allows a user, such as a clinician, the ability to program stimulation parameters for the IPG 14 and ETS 20 in the operating room and in follow-up sessions.

[0044] The CP 18 may perform this function by indirectly communicating with the IPG 14 or ETS 20, through the RC 16, via a wireless communications link 36. Alternatively, the CP 18 may directly communicate with the IPG 14 or ETS 20 via a wireless communications link (not shown). The stimulation parameters provided by the CP 18 are also used to

program the RC 16, so that the stimulation parameters can be subsequently modified by operation of the RC 16 in a stand-alone mode (i.e., without the assistance of the CP 18).

[0045] For purposes of brevity, the details of the RC 16, CP 18, ETS 20, and external charger 22 will not be further described herein. Details of exemplary embodiments of these devices are disclosed in U.S. Pat. No. 6,895,280, which is expressly incorporated herein by reference. Other examples of electrical stimulation systems can be found at U.S. Pat. Nos. 6,181,969; 6,516,227; 6,609,029; 6,609,032; 6,741,892; 7,949,395; 7,244,150; 7,672,734; and 7,761,165; 7,974,706; 8,175,710; 8,224,450; and 8,364,278; and U.S. Patent Application Publication No. 2007/0150036, as well as the other references cited above, all of which are incorporated by reference.

[0046] FIG. 2 illustrates one embodiment of a lead 110 with electrodes 125 disposed at least partially about a circumference of the lead 110 along a distal end portion of the lead and terminals 135 disposed along a proximal end portion of the lead.

The lead 110 can be implanted near or within the desired portion of the body to be stimulated such as, for example, the brain, spinal cord, or other body organs or tissues. In one example of operation for deep brain stimulation, access to the desired position in the brain can be accomplished by drilling a hole in the patient's skull or cranium with a cranial drill (commonly referred to as a burr), and coagulating and incising the dura mater, or brain covering. The lead 110 can be inserted into the cranium and brain tissue with the assistance of a stylet (not shown). The lead 110 can be guided to the target location within the brain using, for example, a stereotactic frame and a microdrive motor system. In some embodiments, the microdrive motor system can be fully or partially automatic. The microdrive motor system may be configured to perform one or more of the following actions (alone or in combination): insert the lead 110, advance the lead 110, retract the lead 110, or rotate the lead 110.

[0047] In some embodiments, measurement devices coupled to the muscles or other tissues stimulated by the target neurons, or a unit responsive to the patient or clinician, can be coupled to the implantable pulse generator or microdrive motor system. The measurement device, user, or clinician can indicate a response by the target muscles or other tissues to the stimulation or recording electrode(s) to further identify the target neurons and facilitate positioning of the stimulation electrode(s). For example, if the target neurons are directed to a muscle experiencing tremors, a measurement device can be used to observe the muscle and indicate changes in, for example, tremor frequency or amplitude in response to stimulation of neurons. Alternatively, the patient or clinician can observe the muscle and provide feedback.

[0048] The lead 110 for deep brain stimulation can include stimulation electrodes, recording electrodes, or both. In at least some embodiments, the lead 110 is rotatable so that the stimulation electrodes can be aligned with the target neurons after the neurons have been located using the recording electrodes.

[0049] Stimulation electrodes may be disposed on the circumference of the lead 110 to stimulate the target neurons. Stimulation electrodes may be ring-shaped so that current projects from each electrode equally in every direction from the position of the electrode along a length of the

lead 110. In the embodiment of FIG. 2, two of the electrodes 120 are ring electrodes 120. Ring electrodes typically do not enable stimulus current to be directed from only a limited angular range around of the lead. Segmented electrodes 130, however, can be used to direct stimulus current to a selected angular range around the lead. When segmented electrodes are used in conjunction with an implantable pulse generator that delivers constant current stimulus, current steering can be achieved to more precisely deliver the stimulus to a position around an axis of the lead (i.e., radial positioning around the axis of the lead). To achieve current steering, segmented electrodes can be utilized in addition to, or as an alternative to, ring electrodes.

[0050] The lead 100 includes a lead body 110, terminals 135, and one or more ring electrodes 120 and one or more sets of segmented electrodes 130 (or any other combination of electrodes). The lead body 110 can be formed of a biocompatible, non-conducting material such as, for example, a polymeric material. Suitable polymeric materials include, but are not limited to, silicone, polyurethane, polyurea, polyurethane-urea, polyethylene, or the like. Once implanted in the body, the lead 100 may be in contact with body tissue for extended periods of time. In at least some embodiments, the lead 100 has a cross-sectional diameter of no more than 1.5 mm and may be in the range of 0.5 to 1.5 mm. In at least some embodiments, the lead 100 has a length of at least 10 cm and the length of the lead 100 may be in the range of 10 to 70 cm.

[0051] The electrodes 125 can be made using a metal, alloy, conductive oxide, or any other suitable conductive biocompatible material. Examples of suitable materials include, but are not limited to, platinum, platinum iridium alloy, iridium, titanium, tungsten, palladium, palladium rhodium, or the like. Preferably, the electrodes are made of a material that is biocompatible and does not substantially corrode under expected operating conditions in the operating environment for the expected duration of use.

[0052] Each of the electrodes can either be used or unused (OFF). When the electrode is used, the electrode can be used as an anode or cathode and carry anodic or cathodic current. In some instances, an electrode might be an anode for a period of time and a cathode for a period of time.

[0053] Deep brain stimulation leads may include one or more sets of segmented electrodes. Segmented electrodes may provide for superior current steering than ring electrodes because target structures in deep brain stimulation are not typically symmetric about the axis of the distal electrode array. Instead, a target may be located on one side of a plane running through the axis of the lead. Through the use of a radially segmented electrode array ("RSEA"), current steering can be performed not only along a length of the lead but also around a circumference of the lead. This provides precise three-dimensional targeting and delivery of the current stimulus to neural target tissue, while potentially avoiding stimulation of other tissue. Examples of leads with segmented electrodes include U.S. Pat. Nos. 8,473,061; 8,571,665; and 8,792,993; U.S. Patent Application Publications Nos. 2010/0268298; 2011/0005069; 2011/0130803; 2011/0130816; 2011/0130817; 2011/0130818; 2011/0078900; 2011/0238129; 2012/0016378; 2012/0046710; 2012/0071949; 2012/0165911; 2012/197375; 2012/0203316; 2012/0203320; 2012/0203321; 2013/0197424; 2013/0197602; 2014/0039587; 2014/0353001; 2014/0358208; 2014/0358209; 2014/0358210; 2015/0045864;

2015/0066120; 2015/0018915; 2015/0051681; U.S. patent application Ser. Nos. 14/557,211 and 14/286,797; and U.S. Provisional Patent Application Ser. No. 62/113,291, all of which are incorporated herein by reference.

[0054] An electrical stimulation lead can be implanted in the body of a patient (for example, in the brain or spinal cord of the patient) and used to stimulate surrounding tissue. In at least some embodiments, it is useful to estimate the effective region of stimulation (often called a volume of activation (VOA) or stimulation field model (SFM)) given the position of the lead and its electrodes in the patient's body and the stimulation parameters used to generate the stimulation. Any suitable method for determining the VOA/SFM and for graphically displaying the VOA/SFM relative to patient anatomy can be used including those described in, for example, U.S. Pat. Nos. 8,326,433; 8,675,945; 8,831,731; 8,849,632; and 8,958,615; U.S. Patent Application Publications Nos. 2009/0287272; 2009/0287273; 2012/0314924; 2013/0116744; 2014/0122379; and 2015/0066111; and U.S. Provisional Patent Application Ser. No. 62/030,655, all of which are incorporated herein by reference. Several of these references also disclose methods and systems for registering an atlas of body structures to imaged patient physiology.

[0055] In conventional systems, a VOA is determined based on a set of stimulation parameters input into the system. The VOA can then be modified by the user by modifying the stimulation parameters and determining the new VOA from the modified stimulation parameters. This allows the user to tailor the stimulation volume.

[0056] In contrast to these conventional systems which determine the VOA from user-selected stimulation parameters, in at least some embodiments, the present systems or methods allow the user to define the target that is desired for stimulation and then the systems or methods determine a set of stimulation parameters based on that target. There are a number of different methods for selecting a desired stimulation target described below. In some embodiments, the user selects the volume directly. In other embodiments, the user selects the target indirectly by indicating an anatomical structure, disease or disorder, clinical goal, or system goal, or any combination thereof. #

[0057] FIG. 3 illustrates one embodiment of a system for practicing the invention. The system can include a computing device 300 or any other similar device that includes a processor 302 and a memory 304, a display 306, an input device 308, and, optionally, the electrical stimulation system 312. The system 300 may also optionally include one or more imaging systems 310.

[0058] The computing device 300 can be a computer, tablet, mobile device, or any other suitable device for processing information. The computing device 300 can be local to the user or can include components that are non-local to the computer including one or both of the processor 302 or memory 304 (or portions thereof). For example, in some embodiments, the user may operate a terminal that is connected to a non-local computing device. In other embodiments, the memory can be non-local to the user.

[0059] The computing device 300 can utilize any suitable processor 302 including one or more hardware processors that may be local to the user or non-local to the user or other components of the computing device. The processor 302 is configured to execute instructions provided to the processor, as described below.

[0060] Any suitable memory 304 can be used for the computing device 302. The memory 304 illustrates a type of computer-readable media, namely computer-readable storage media. Computer-readable storage media may include, but is not limited to, nonvolatile, non-transitory, removable, and non-removable media implemented in any method or technology for storage of information, such as computer readable instructions, data structures, program modules, or other data. Examples of computer-readable storage media include RAM, ROM, EEPROM, flash memory, or other memory technology, CD-ROM, digital versatile disks ("DVD") or other optical storage, magnetic cassettes, magnetic tape, magnetic disk storage or other magnetic storage devices, or any other medium which can be used to store the desired information and which can be accessed by a computing device.

[0061] Communication methods provide another type of computer readable media; namely communication media. Communication media typically embodies computer-readable instructions, data structures, program modules, or other data in a modulated data signal such as a carrier wave, data signal, or other transport mechanism and include any information delivery media. The terms "modulated data signal," and "carrier-wave signal" includes a signal that has one or more of its characteristics set or changed in such a manner as to encode information, instructions, data, and the like, in the signal. By way of example, communication media includes wired media such as twisted pair, coaxial cable, fiber optics, wave guides, and other wired media and wireless media such as acoustic, RF, infrared, and other wireless media.

[0062] The display 306 can be any suitable display device, such as a monitor, screen, display, or the like, and can include a printer. The input device 308 can be, for example, a keyboard, mouse, touch screen, track ball, joystick, voice recognition system, or any combination thereof, or the like.

[0063] One or more imaging systems 310 can be used including, but not limited to, MRI, CT, ultrasound, or other imaging systems. The imaging system 310 may communicate through a wired or wireless connection with the computing device 300 or, alternatively or additionally, a user can provide images from the imaging system 310 using a computer-readable medium or by some other mechanism.

[0064] The electrical stimulation system 312 can include, for example, any of the components illustrated in FIG. 1. The electrical stimulation system 312 may communicate with the computing device 300 through a wired or wireless connection or, alternatively or additionally, a user can provide information between the electrical stimulation system 312 and the computing device 300 using a computer-readable medium or by some other mechanism. In some embodiments, the computing device 300 may include part of the electrical stimulation system, such as, for example, the IPG, CP, RC, ETS, or any combination thereof.

[0065] The methods and systems described herein may be embodied in many different forms and should not be construed as limited to the embodiments set forth herein. Accordingly, the methods and systems described herein may take the form of an entirely hardware embodiment, an entirely software embodiment or an embodiment combining software and hardware aspects. Systems referenced herein typically include memory and typically include methods for communication with other devices including mobile devices. Methods of communication can include both wired

and wireless (e.g., RF, optical, or infrared) communications methods and such methods provide another type of computer readable media; namely communication media. Wired communication can include communication over a twisted pair, coaxial cable, fiber optics, wave guides, or the like, or any combination thereof. Wireless communication can include RF, infrared, acoustic, near field communication, Bluetooth™, or the like, or any combination thereof.

[0066] Programming an electrical stimulation (for example, a deep brain stimulation (DBS) or spinal cord stimulation (SC S)) system has conventionally involved significant time spent by a variety of programming experts, having varying levels of training and experience, with those programmers subscribing to various schools of thought regarding the choice of stimulation parameters. A preferred programming solution would offer tools to users or programmers to program more quickly, to more often arrive at efficacious sets of stimulation parameters, and to increase the efficacy of the patient's therapy.

[0067] In at least some embodiments, two different tasks can be identified: Targeting and Steering. Targeting can refer to, for example, an automated or semi-automated selection of a set of stimulation parameters based on any number or type of data or criteria. Steering (for example, current steering) can refer to the automated or semi-automated selection of sets of stimulation parameters resulting in stepwise changes to stimulation, again based on any number of type of data or criteria. In at least some embodiments, targeting can be the selection of a final set of stimulation parameters which achieve a desired stimulation goal, and steering can be a method of exploring the stimulation parameter space using, for example, abstracted controls.

[0068] In one embodiment of a method of selecting stimulation parameters (e.g., targeting), the user employs alphanumeric descriptors, instead of visual or graphical views, to describe the objective of the electrical stimulation therapy. The system can use these alphanumeric descriptors, as well as data from actual or estimated stimulation instances, to select at least one set of stimulation parameters to achieve the described objective. In at least some embodiments, no graphical views are presented to the user. In at least some embodiments, no imaging data is required. In some other embodiments, imaging data related to surgical placement of the lead or imaging data of the anatomical structures in which the lead is (or is to be) placed, or graphical data relating to physiological structures or responses to stimulation mapped to 3D or anatomical space or a common space, such as MNI space, or any combination thereof may optionally be provided.

[0069] FIG. 4 illustrates a flowchart of one method of selecting stimulation parameters using alphanumeric descriptors. In step 402, the user provides the name of an anatomical or physiological target. Examples of such targets include, but are not limited to, the subthalamic nucleus (STN), internal segment of the globus pallidus (GPi), external segment of the globus pallidus (GPe), and the like. In at least some embodiments, an anatomical structure is defined by its physical structure and a physiological target is defined by its functional attributes. The user may input the name of the anatomical or physiological target using a keyboard, touchscreen, voice-recognition system, or any other suitable input device. Additionally or alternatively, the user may select the anatomical or physiological target from a list using, for example, a drop-down menu or any other suitable

selection mechanism. In some embodiments, there can be more than one anatomical or physiological target provided.

[0070] In step 404, the user provides the name of a disease or disorder (e.g. Parkinson's disease, depression, epilepsy) that is to be treated. In some instances, the disease or disorder may be a symptom or condition associated with another disease or disorder. The user may input the name of the disease or disorder using a keyboard, touchscreen, voice-recognition system, or any other suitable input device. Additionally or alternatively, the user may select the disease or disorder from a list using, for example, a drop-down menu or any other suitable selection mechanism. In some embodiments, the system may present a list for the disease or disorder based on the previously provided anatomical or physiological target. In some embodiments, there can be more than one disease or disorder provided. In some embodiments, step 402 is skipped and the user-provided name from step 404 is utilized by the system to select a target (which can be an anatomical or physiological target) or to present a list of targets to the user.

[0071] In step 406, the user provides a clinical goal. In at least some embodiments, the clinical goal may be input as a verb/noun combination, for example, 'reduce'+ 'tremor' or 'avoid'+ 'cognitive impairment'. The clinical goal generally refers the disease or disorder or to a symptom of the disease or disorder or to an effect or side effect associated with the disease or disorder or with electrical stimulation of the anatomical or physiological target. The user may input the clinical goal using a keyboard, touchscreen, voice-recognition system, or any other suitable input device. Additionally or alternatively, the user may select the clinical goal from a list using, for example, a drop-down menu or any other suitable selection mechanism. In some embodiments, the system may present a list for the clinical goal based on the previously provided anatomical or physiological target or provided disease or disorder or both. In some embodiments, there can be more than one clinical goal provided. In some embodiments, one or more clinical goals can be suggested by the system based on selections made in steps 402, 404, or 408.

[0072] In optional step 408, the user can provide a system goal, such as, for example, 'extended battery life', 'low frequency', 'short pulse width', or the like. The system goal generally refers to one or more of the components of the stimulation system or to one or more of the stimulation parameters and indicates an objective related to the component or parameter. The user may input the system goal using a keyboard, touchscreen, voice-recognition system, or any other suitable input device. Additionally or alternatively, the user may select the system goal from a list using, for example, a drop-down menu or any other suitable selection mechanism. In some embodiments, there can be more than one system goal provided. In some embodiments, one or more system goals can be suggested by the system based on selections made in steps 402, 404, or 406.

[0073] It will be understood that steps 402, 404, 406, and 408 can be rearranged in any order. In step 410, the system uses the provided inputs from steps 402, 404, 406, and 408 to select a set of stimulation parameters. In at least some embodiments, the system can utilize previous actual or estimated stimulation instances to correlate with the selections or inputs made by the user. For example, the anatomical or physiological target and, optionally, the disease or disorder and clinical goal, may be used to identify a target

region for stimulation. In some embodiments, the anatomical or physiological target, disease or disorder, clinical goal, or system goal (or any combination thereof) may provide limits (for example, ranges, maximum values, or minimum values, or sets of combinations of parameters) for one or more stimulation parameters. Examples of methods to determine stimulation parameters are described in more detail below.

[0074] FIG. 5 illustrates another method for selecting stimulation parameters. In step 502, a graphical user interface (GUI) is presented with one or more views containing a two-dimension (2D) or three-dimensional (3D) representation of the lead or leads present, as well as optional anatomical structure or structures. The views may also contain notional views of programming parameters space, including or excluding displays of responses to stimulation from the existing patient, prior patients, or populations of patients. For a 3D representation, elements displayed may be displayed as a 2D view into a 3D space, or using 3D technology (e.g. active displays, active glasses, passive glasses, holograms, haptic feedback 'display'). Patient-specific imaging data may optionally be provided (e.g. pre-operative MRI/CT, intra-operative MRI/CT, post-operative MRI/CT, or the like or any combination thereof).

[0075] In step 504, the user selects at least one target. In some embodiments, the user selects at least one anatomical target. For example, the user can select an anatomical target that is shown on a display using any suitable selection device, such as a touchscreen, mouse, touchpad, track ball, or the like, or the user can select an anatomical target from a drop-down menu or the like or the user can utilize any other suitable selection mechanism.

[0076] In other embodiments, the user can select at least one target volume, which is not a specific anatomical structure, but may include parts of one or more anatomical structures. The target volume may be displayed in the one or more views of the GUI. In at least some embodiments, the target volume can be drawn or otherwise indicated by the user. In at least some embodiments, a sample target volume can be displayed and the user can manipulate the sample target volume by, for example, changing boundaries of the sample target volume, changing a diameter of the sample target volume, or the like. In at least some embodiments, the target volume can be estimated based on, for example, a selection of disease state, surgical target, an auto-segmentation method, or the like and then, at least in some instances, optionally modified by the user.

[0077] Methods for selecting a target are illustrated using FIGS. 6A and 6B. FIG. 6A illustrates diagrammatically one embodiment of a view 600 into a 3D space. The lead 602 and its electrodes 634 (FIG. 6B) are illustrated in the center of the view. The ellipse signifies a target 603, such as an anatomical or physiological target. In this case, the lead 602 has been positioned at least partially within the target 603, but in other embodiments, the lead may be near, but not inside, the target. The target 603 may have been selected using patient imaging data (e.g. MRI) or an atlas (a patient specific, probabilistic, or general atlas), or the user may have drawn the target. The view also includes an axis indicator 605, which shows the orientation of different views into the space.

[0078] In some embodiments, a target point 607 can be selected. In some embodiments, the target 603 or target point 607 is automatically placed by the system (using, for

example, the input described above with respect to FIG. 4) or the target 603 is automatically placed with some user input (for example, if the user can move or otherwise select a target point 607). In other embodiments, the target 603 is placed entirely by the user. In some embodiments, using the target point 607, a target volume can be determined. For example, the selection of a particular target point 607 can be used to result in the selection of a larger target 603 based on, for example, anatomical or physiological information. For example, a target point placed in a region of the STN may result in the automatic selection of the entire STN as the target.

[0079] A dashed line 610 in FIG. 6A shows the location of a cutaway plane for the view illustrated in FIG. 6B. FIGS. 6A and 6B may show two views into a single viewport at different times, or two views shown in two different viewports to the user at the same time. In some embodiments, the user can graphically or otherwise manipulate the views, such as, for example, sliding or otherwise moving the cut plane in FIG. 6A to alter the image shown in FIG. 6B.

[0080] In at least some embodiments, one or more targets 603 can be identified by the user. These targets 603 may be constructed using the GUI. A target 603 may be constructed entirely from scratch, or by using a set of primitives (for example, lines, spheres, cubes, rectangles, circles, triangles, or the like or any combination thereof), or in a stepwise fashion by modifying an initial target. For example, a user may place a sphere primitive in the space, and then modulate its radius or transition it to an ellipsoid with two axes. Targets may be combined as a union or an intersection to form final targets. Targets may be constructed out of a series of outlines in various planes. For example, the user may draw an outline on each of three orthogonal planes (e.g. first the xy plane, then the yz plane, then the xz plane.)

[0081] Returning to FIG. 5, in optional step 506, a type of neurostimulation intervention is selected for one or more of the targets. Types of neurostimulation intervention can include, for example, stimulation (application of a stimulating field or drug), activation (actuating neurological tissue), depression (reducing the likelihood of activation of the neurological tissue), silencing (preventing the activation of the neurological tissue), or other forms of neuromodulation. Multiple forms of neuromodulation as described previously may be used in various combinations, with varying temporal order or relation, on the same target or targets. The intervention can be accomplished using electrical stimulation, optical stimulation, drug stimulation, or the like or any combination thereof. The one or more targets may be selected with respect to the desired type of intervention, for example, one or more targets can be selected for activation, one or more targets for depression, and one or more targets for silencing, or any combination thereof. When multiple targets are identified, the targets may be selected for the same type of intervention or different targets may be selected for different types of intervention.

[0082] In at least some embodiments, the user indicates a type of neurological intervention for each target. In some embodiments, a default type of neurological intervention (for example, stimulation or activation) is assumed unless the user selects a different type of neurological intervention. In some embodiments, the user can select the type of neurological intervention from a pull-down menu, optionally associated or displayed on the target, or by any other selection technique.

[0083] In optional step **508**, the user provides the name of a disease or disorder (e.g. Parkinson's disease, depression, epilepsy) that is to be treated. In some instances, the disease or disorder may be a symptom or condition associated with another disease or disorder. The user may input the name of the disease or disorder using a keyboard, touchscreen, voice-recognition system, or any other suitable input device. Additionally or alternatively, the user may select the disease or disorder from a list using, for example, a drop-down menu or any other suitable selection mechanism. In some embodiments, the system may present a list for the disease or disorder based on the previously provided target. In some embodiments, there can be more than one disease or disorder provided.

[0084] In optional step **510**, the user provides a clinical goal or a system goal or any combination thereof. In at least some embodiments, the clinical goal may be input as a verb/noun combination, for example, 'reduce'+ 'tremor' or 'avoid'+ 'cognitive impairment'. The clinical goal generally refers to a disease or disorder or to a symptom of the disease or disorder or to a side-effect associated with the disease, disorder, or stimulation. The system goal generally refers to one or more of the components of the stimulation system or to one or more of the stimulation parameters and indicates an objection related to the component or parameter, such as, for example, 'extended battery life', 'low frequency', 'short pulse width', or the like. The user may input the clinical or system goal using a keyboard, touchscreen, voice-recognition system, or any other suitable input device. Additionally or alternatively, the user may select the clinical or system goal from a list using, for example, a drop-down menu or any other suitable selection mechanism. In some embodiments, the system may present a list for the clinical or system goal based on the previously provided target or provided disease or disorder or both. In some embodiments, there can be more than one clinical or system goal provided.

[0085] It will be understood that steps **504**, **506**, **508**, or **510** can be rearranged in any order. In step **512**, the system uses the provided inputs from steps **504**, **506**, **508**, or **510** to select a set of stimulation parameters. In at least some embodiments, the system can utilize previous actual or estimated stimulation instances to correlate with the selections or inputs made by the user.

[0086] When selecting stimulation parameters, for example, according to step **410** in FIG. 4 of step **512** in FIG. 5, individual parameters may be limited based on one or more considerations, such as, for example, the anatomical structures that are targeted or on the disease or disorder being treated (or any combination thereof). For example, if the chosen target volume includes the STN, optionally with Parkinson's disease (PD) or essential tremor (ET) as an indication, the system may identify a range of pulse rates (e.g. 60-10,000 Hz), or a range of pulse widths (e.g. 30-90 μ s). These limits may be a range limit, a maximum limit, a minimum limit, a set of allowed parameter combinations, or the like. In an alternative or combined manner, the user may prescribe or modify one or more settings, for example, pulse width, rate, pulse regularity, waveform shape, pulse train information, spatio-temporal patterns, or the like.

[0087] Any suitable method can be used to select stimulation parameters including methods disclosed in copending U.S. Provisional Patent Application Ser. No. 62/186,184, entitled "Systems and Methods for Analyzing Electrical Stimulation and Selecting or Manipulating Volumes of Acti-

vation", Attorney Docket No. BSNC-1-395.0, filed on even date herewith. The anatomical region that is stimulated for a particular set of stimulation parameters can be estimated using any suitable estimation technique. These estimates can include, for example, estimates of axonal activation, estimates of cell bodies that are activated, estimates of fiber pathways that are activated, and the like or any combination thereof. In at least some instances, the estimate is called a value of activation (VOA) or stimulation field model (SFM) Examples of suitable methods for making these estimations include, but are not limited to, those described in U.S. Pat. Nos. 8,326,433; 8,675,945; 8,831,731; 8,849,632; and 8,958,615; U.S. Patent Application Publications Nos. 2009/0287272; 2009/0287273; 2012/0314924; 2013/0116744; 2014/0122379; and 2015/0066111; and U.S. Provisional Patent Application Ser. No. 62/030,655, all of which are incorporated herein by reference. It will be understood that other methods of estimating the stimulation region that do not use the stimulation parameters can also be employed.

[0088] The estimated stimulation region can be compared to the target to determine correspondence to the target. In at least some embodiments, the system or user can set a threshold (for example, a percentage overlap between the estimated stimulation region and the target or a percentage difference between the target and the estimate stimulation region) which when met by the comparison indicates that a set of stimulation parameters can be accepted as a final set of stimulation parameters. In some embodiments, a set of stimulation parameters can be arrived at iteratively based on the comparison and subsequent modification of the stimulation parameters. Such an iterative process can be performed automatically by a processor or performed semi-automatically with occasional input from the user or can be performed with user input to direct which parameters to modify or the amount of the modifications. In other embodiments, a system may compare a target with previously determined estimations (for example, a set of previously calculated VOAs or SFMs) and select a set of parameters based on these comparisons.

[0089] In at least some embodiments, the set of stimulation parameters may include one or more subsets of stimulation parameters to provide a neuromodulation intervention for more than one (overlapping or non-overlapping) targets or to provide a neuromodulation intervention for a particular target at different times. The neuromodulation intervention in the multiple targets can be performed in time-dependent manner (e.g. target **1** occurs first, target **2** next, and so forth). Neuromodulation intervention in the multiple targets may or may not overlap spatially or temporally.

[0090] Targets, or estimated stimulation regions based on stimulation parameters, may be displayed to the user as a static image or as an animation (e.g. when multiple target volumes are present at multiple times). The display of targets, or estimated stimulation regions based on stimulation parameters, may be based on any type of construct, such as, for example, an electrical potential distribution, electric field, divergence of electric field (activating function), the Hermitian of the activating function, a Volume of Activation (VOA) model, or a Stimulation Field Model (SFM) or the like which considers the effects of the neuromodulation intervention on active neural elements in the target and deterministically quantifies the effect, allowing for the display of continuous (e.g. threshold) or discrete (e.g. binary fire/no-fire) data. Targets, or estimated stimulation regions

based on stimulation parameters, may be displayed as 2D contours or 3D surfaces at a variety of thresholds (for example, electrical potential, electrical field, or the like which could be chosen by the user or method) or planar cutaways with overlaid false color maps. Different targets, or estimated stimulation regions based on stimulation parameters, may be distinguished by, for example, color, texture, luminosity, or the like.

[0091] In at least some embodiments, the user can modify the previously identified set of stimulation parameters. In at least some embodiments, an estimated stimulation region can be displayed based on the modified stimulation parameters.

[0092] In an alternative to the methods illustrated in FIGS. 4 and 5, after the user or system selects one or more targets, the system or the user can engage in a steering technique to select the stimulation parameters. FIG. 7 is a flowchart of one method of steering a set of initial stimulation parameters in order to obtain a set of final stimulation parameters. In step 702 an initial set of stimulation parameters is provided. The set can be provided in any manner including using any of the methods described above. Alternatively, the set of initial stimulation parameters can be selected using any other technique. Optionally, a GUI can display a representation of the field generated using these parameters, a volume of activation or stimulation generated using these parameters, or a lead graphically or alphanumerically presenting the parameters, or any other representation, or any combination of these representations. In other embodiments, there is no graphical representation of the lead or region of stimulation.

[0093] In step 704, the user provides an alphanumeric command to alter one or more of the stimulation parameters. In at least some embodiments, this command does not include, or is not composed exclusively of, a numerical value for any of the stimulation parameters. This command can include one or more words that direct modification of the stimulation parameters to obtain the goal recited in the command. Examples of such words include, but are not limited to, 'up', 'down', 'left', 'right', 'clockwise', 'counterclockwise', 'spread', 'focus', 'faster', 'slower', 'longer', 'shorter', and so forth. These commands are abstract steering controls that can affect, for example, the number or selection of active electrodes, the polarity and amplitude of the electrodes, pulse width, frequency, amplitude, inter-pulse interval, regularity, and the like of the stimulation.

[0094] In optional step 706, the modification of the stimulation parameters is observed. In some embodiments, the modification can be observed, for example, by a change in a display of the representation of the field generated using these parameters or a volume of activation or a volume of stimulation generated using these parameters. In some embodiments, the modification can be observed as a stimulation effect or side effect that is noted by the user or patient. The user or patient may provide a rating of the stimulation parameters.

[0095] In step 708, the modification and observation steps (steps 704 and 706) can be repeated to perform further modifications of the stimulation parameters. This process can continue until a final set of stimulation parameters is obtained.

[0096] FIG. 8 is a flowchart of one method of steering a set of initial stimulation parameters in order to obtain a set of final stimulation parameters. In step 802 an initial set of stimulation parameters is provided. The set can be provided

in any manner including using any of the methods described above. Alternatively, the set of initial stimulation parameters can be selected using any other technique. A GUI displays a representation of the field generated using these parameters, a volume of activation or stimulation generated using these parameters, or a lead graphically or alphanumerically presenting the parameters, or any other representation, or any combination of these representations.

[0097] Using a graphical interface, in step 802 the user modifies the stimulation parameters. For example, the interface can include components for selecting which electrodes to activate; components for raising or lowering parameters such as amplitude, frequency, pulse width, or the length; and so forth. In other embodiments, the interface may permit the user to modify the field or volume of activation generated using the parameters and then the system can calculate the new set of stimulation parameters based on the modified field or volume.

[0098] In optional step 806, the modification of the stimulation parameters is observed. In some embodiments, the modification can be observed, for example, a change in a display of the representation of the field generated using these parameters or a volume of activation or a volume of stimulation generated using these parameters. In some embodiments, the modification can be observed as a stimulation effect or side effect that is noted by the user or patient. The user or patient may provide a rating of the stimulation parameters.

[0099] In step 808, the modification and observation steps (steps 804 and 806) can be repeated to perform further modifications of the stimulation parameters. This process can continue until a final set of stimulation parameters is obtained.

[0100] In at least some embodiments of a method of selecting stimulation parameters, a coarse exploration of the parameter space is made with abstracted steering controls (such as the methods in FIG. 7 or 8), and then a targeting method (such as the methods of FIG. 4 or 5) predicts a set of stimulation parameters for the target, and then a subsequent pass with steering controls is made. This process can be iterated. It has also been found that in some steering methods, if the current or field is steered from one combination of electrodes to a different combination, or from a combination of electrodes to a single electrode (or vice versa), certain descriptive parameters may change, for example, the radius of the volume of tissue activated, the cumulative rate experienced, the total power injected, or the like. For example, steering a current or field from two electrodes A and B to a single electrode B may increase the radius of the area of stimulation. The system can be arranged to account for this and, instead, maintain the radius of the area of stimulation constant by modifying the stimulation parameters accordingly. The system can be configured to maintain one or more characteristics constant, or to adjust them as parameters are adjusted.

[0101] FIGS. 9A and 9B illustrate another method of identifying a target using a lead 902 and target point 907 from two orthogonal views. (FIGS. 9A and 9B also illustrate an axis indicator 905.) The user or system places the target point 907. The system projects back a line 909 from the target point 907 to the surface of the lead 902. In some embodiments, the line 909 can be a minimum distance line from the target point 907 to the surface of the lead 902. At the intersection of the lead and this projected line, a point

source **911** is identified. This point source **911** can be used to model a monopolar point source (for example, cathodic) field. Other virtual electrical elements may be employed instead of a point source, such as a combination of point sources or a virtual electrode having some other form than the real electrodes on the lead. Alternatively, closed form solutions to approximating electrodes may be used. The virtual electrode or electrodes may, or may at times, take the form and position of one or more electrodes in the real electrode array. The user may select the boundaries of the virtual electrode or the system can determine boundaries which are optionally user-adjustable. Although a point source will be used below for illustrative purposes, it will be understood that a combination of point sources or a virtual electrode can be used instead of the point source.

[0102] FIG. 10 illustrates one embodiment of a point source **911** on a lead **902**. In this embodiment, when calculating the potential field **913** for each point source **911**, only the region not overlapping the lead, bounded by the plane tangent to the lead at the point is used. In this calculation, the current only contributing to $\frac{1}{2}$ of the volume is considered so double the current I used to calculate the current at each point $V(r)=2I/4\pi r\sigma$ where r is the distance from the point source and σ is the conductivity. In other embodiments, the solution for a point source on the exterior of an insulating rod may be used.

[0103] The system then uses the extant electrodes **934** of the lead **902** to determine a best-fit (for example, using a least squares calculation) to this point source field by activating the electrodes using a set of stimulation parameters to approximate the point source field. The point source field may be a scalar potential field, a vector field (for example, an electric field, or divergence of the electric field), or a field of Hamiltonians of the divergence of the electric field, or the like. In some embodiments, the user can modify the resulting stimulation parameters to modify the field. For example, the user may ‘focus’ or ‘spread’ the field radially or longitudinally. In at least some embodiments, radial focus can involve the addition of anodes antipodal to the target point.

[0104] In another embodiment, the target electric field may be computed from combinations of pre-computed basis fields, or by the combination of solutions of analytic fits to pre-computed data.

[0105] Instead of designating a target point, a user can alternatively designate a virtual electrode and use this electrode to generate stimulation. The system can then select stimulation parameters using the actual electrodes of the lead to approximate the virtual electrode. FIG. 11 illustrates a lead **1102** with electrodes **1134**. The user can place and edit a virtual electrode **1135** on the surface of the lead **1132**. The virtual electrode **1135** can have any desired shape (for example, circle, rectangle, triangle, or the like) which can be curved, if desired, or even form a ring around the lead. Typically, the virtual electrode is limited to the span of the electrode array.

[0106] In some embodiments, edges or segments of edges of the virtual electrode can be set to ‘guard’ to reduce or prevent extending the field generated by the virtual electrode beyond the edges. For example, if the virtual electrode is a cathode, the guarded edges can provide anodic guarding. In at least some embodiments, the strength of guarding can be set, independently for each edge or segment. FIG. 12 illustrates anodic guarding handled by creating one or more

virtual guarding electrodes **1137**, one for each edge of the virtual electrode **1135** of the lead **1102** which is guarded, and moving them closer or strengthening them as the user increases the level of guarding.

[0107] In any of the systems and methods described above, when a set of stimulation parameters is determined, the set of stimulation parameters can be communicated to an IPG, ETS, or other device.

[0108] It will be understood that the system can include one or more of the methods described hereinabove with respect to FIGS. 4-12 in any combination. The methods, systems, and units described herein may be embodied in many different forms and should not be construed as limited to the embodiments set forth herein. Accordingly, the methods, systems, and units described herein may take the form of an entirely hardware embodiment, an entirely software embodiment or an embodiment combining software and hardware aspects. The methods described herein can be performed using any type of processor or any combination of processors where each processor performs at least part of the process.

[0109] It will be understood that each block of the flowchart illustrations, and combinations of blocks in the flowchart illustrations and methods disclosed herein, can be implemented by computer program instructions. These program instructions may be provided to a processor to produce a machine, such that the instructions, which execute on the processor, create means for implementing the actions specified in the flowchart block or blocks disclosed herein. The computer program instructions may be executed by a processor to cause a series of operational steps to be performed by the processor to produce a computer implemented process. The computer program instructions may also cause at least some of the operational steps to be performed in parallel. Moreover, some of the steps may also be performed across more than one processor, such as might arise in a multi-processor computer system. In addition, one or more processes may also be performed concurrently with other processes, or even in a different sequence than illustrated without departing from the scope or spirit of the invention.

[0110] The computer program instructions can be stored on any suitable computer-readable medium including, but not limited to, RAM, ROM, EEPROM, flash memory or other memory technology, CD-ROM, digital versatile disks (“DVD”) or other optical storage, magnetic cassettes, magnetic tape, magnetic disk storage or other magnetic storage devices, or any other medium which can be used to store the desired information and which can be accessed by a computing device.

[0111] The above specification provides a description of the structure, manufacture, and use of the invention. Since many embodiments of the invention can be made without departing from the spirit and scope of the invention, the invention also resides in the claims hereinafter appended.

What is claimed as new and desired to be protected by Letters Patent of the United States is:

1. A system for identifying a set of stimulation parameters, the system comprising:

a computer processor configured and arranged to perform the following actions:

providing a model of a lead comprising a plurality of electrodes, wherein the plurality of electrodes comprises a plurality of the segmented electrodes forming at least one set of segmented electrodes, wherein

- each set of segmented electrodes comprises a plurality segmented electrodes disposed around a circumference of the lead at a same longitudinal position along the lead;
- receiving a selection of a target point external to the lead;
- projecting the target point onto a surface of the lead to identify a virtual electrode; and
- selecting a set of stimulation parameters for at least one of the electrodes to approximate an electrical field generated from the virtual electrode.
2. The system of claim 1, wherein projecting the target point comprises projecting the target point onto a nearest point of the surface of the lead to identify the virtual electrode.
3. The system of claim 1, wherein the actions further comprise calculating the electrical field in a region that does not overlap with the lead and is bounded by a plane tangent to the lead at the virtual electrode.
4. The system of claim 1, wherein the electrical field is a scalar potential field, a vector field, or a field of Hamiltonians of a divergence of an electrical field.
5. The system of claim 1, wherein the actions further comprise receiving a user modification of at least one of the stimulation parameters.
6. The system of claim 1, wherein the actions further comprise defining at least one guarding electrode adjacent the virtual electrode.
7. The system of claim 6, wherein defining at least one guarding electrode comprises defining two guarding electrodes circumferentially disposed on opposite sides of the virtual electrode.
8. The system of claim 1, wherein the virtual electrode is modeled as a monopolar point source.
9. The system of claim 1, wherein the actions further comprises receiving a user modification to modify the electrical field radially.
10. The system of claim 1, wherein the actions further comprises receiving a user modification to modify the electrical field longitudinally.
11. A system for identifying a set of stimulation parameters, the system comprising:
 a computer processor configured and arranged to perform the following actions:
 receiving a first set of stimulation parameters;
 receiving a command to alter the first set of stimulation parameters, wherein the command does not include,

- or is not composed exclusively of, a numerical value for any of the stimulation parameters; and
 modifying the first set of stimulation parameters to create a second set of stimulation parameters based on the command.
12. The system of claim 11, wherein the actions further comprise displaying, on a display, an estimated stimulation region based on the first set of stimulation parameters.
13. The system of claim 12, wherein the actions further comprise upon modification of the first set of stimulation parameters to create the second set of stimulation parameters, modifying the display to display an estimated stimulation region based on the second set of stimulation parameters.
14. The system of claim 11, wherein the actions further comprise receiving a user modification of at least one of the stimulation parameters of the second set of stimulation parameters.
15. The system of claim 11, wherein the actions further comprise repeating the actions with the second set of stimulation parameters becoming the first set of stimulation parameters for the repeated actions.
16. The system of claim 11, wherein the action further comprise sending the second set of stimulation parameters to an implantable pulse generator of an electrical stimulation system.
17. The system of claim 11, wherein receiving the command comprises receiving a non-numerical directional command to shift an electrical field generated in response to the first set of stimulation parameters in a direction specified by the directional command.
18. The system of claim 11, wherein receiving the command comprises receiving a non-numerical command to alter a size of an electrical field generated in response to the first set of stimulation parameters in a manner specified by the non-numerical command.
19. The system of claim 11, wherein the command does not include a numerical value.
20. The system of claim 11, wherein receiving the command comprises receiving a non-numerical stimulation steering command to shift an electrical field generated in response to the first set of stimulation parameters in a manner specified by the non-numerical stimulation steering command.

* * * * *