

(19) World Intellectual Property  
Organization  
International Bureau



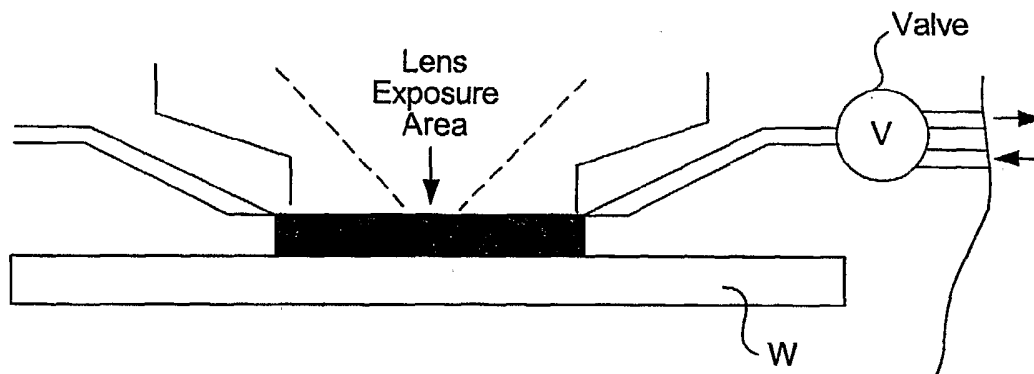
(43) International Publication Date  
28 October 2004 (28.10.2004)

PCT

(10) International Publication Number  
**WO 2004/092830 A2**

- (51) International Patent Classification<sup>7</sup>: **G03F**
- (21) International Application Number:  
PCT/US2004/010071
- (22) International Filing Date: 1 April 2004 (01.04.2004)
- (25) Filing Language: English
- (26) Publication Language: English
- (30) Priority Data:  
60/462,786 11 April 2003 (11.04.2003) US
- (71) Applicant (for all designated States except US): **NIKON CORPORATION** [JP/JP]; 2-3 Marunouchi, 3-Chome, Chiyoda-ku, Tokyo 100-8331 (JP).
- (72) Inventors; and
- (75) Inventors/Applicants (for US only): **NOVAK, W., Thomas** [US/US]; 1205 Lakeview Drive, Hillsborough, CA 94010 (US). **HAZELTON, Andrew, J.** [US/US]; 409 Phelps Road, San Carlos, CA 94070 (US). **WATSON, Douglas, C.** [US/US]; 1353 Cameo Drive, Campbell, CA 95008 (US).
- (74) Agent: **NISHIMURA, Keiichi**; Beyer Weaver & Thomas LLP, P.O. Box 778, Berkeley, CA 94604-0778 (US).
- (81) Designated States (unless otherwise indicated, for every kind of national protection available): AE, AG, AL, AM, AT, AU, AZ, BA, BB, BG, BR, BW, BY, BZ, CA, CH, CN, CO, CR, CU, CZ, DE, DK, DM, DZ, EC, EE, EG, ES, FI, GB, GD, GE, GH, GM, HR, HU, ID, IL, IN, IS, JP, KE, KG, KP, KR, KZ, LC, LK, LR, LS, LT, LU, LV, MA, MD, MG, MK, MN, MW, MX, MZ, NA, NI, NO, NZ, OM, PG, PH, PL, PT, RO, RU, SC, SD, SE, SG, SK, SL, SY, TJ, TM, TN, TR, TT, TZ, UA, UG, US, UZ, VC, VN, YU, ZA, ZM, ZW.
- (84) Designated States (unless otherwise indicated, for every kind of regional protection available): ARIPO (BW, GH, GM, KE, LS, MW, MZ, SD, SL, SZ, TZ, UG, ZM, ZW), Eurasian (AM, AZ, BY, KG, KZ, MD, RU, TJ, TM), European (AT, BE, BG, CH, CY, CZ, DE, DK, EE, ES, FI, FR, GB, GR, HU, IE, IT, LU, MC, NL, PL, PT, RO, SE, SI, SK, TR), OAPI (BF, BJ, CF, CG, CI, CM, GA, GN, GQ, GW, ML, MR, NE, SN, TD, TG).
- Published:**  
— without international search report and to be republished upon receipt of that report
- For two-letter codes and other abbreviations, refer to the "Guidance Notes on Codes and Abbreviations" appearing at the beginning of each regular issue of the PCT Gazette.

(54) Title: LIQUID JET AND RECOVERY SYSTEM FOR IMMERSION LITHOGRAPHY



(57) Abstract: A liquid jet and recovery system for an immersion lithography apparatus has arrays of nozzles arranged to have their openings located proximal to an exposure region through which an image pattern is projected on a workpiece such as a wafer. These nozzles are each adapted to serve selectively either as a source nozzle for supplying a fluid into the exposure region or as a recovery nozzle for recovering the fluid from the exposure region. A fluid controlling device functions to cause nozzles on selected one or more sides of the exposure region to serve as source nozzles and those on selected one or more of the remaining sides to serve as recovery nozzles such that a desired flow pattern can be established for the convenience of immersion lithography.

WO 2004/092830 A2

## LIQUID JET AND RECOVERY SYSTEM FOR IMMERSION LITHOGRAPHY

5

### CROSS-REFERENCE TO RELATED APPLICATION

This application claims priority to U.S. Provisional Patent Application No. 60/462,786 filed April 11, 2003, which is hereby incorporated by reference in its entirety.

10

### BACKGROUND OF THE INVENTION

This invention relates to a liquid jet and recovery system for an immersion lithography apparatus, adapted to supply a liquid into the space between a workpiece such as a wafer and the last-stage optical element such as a lens of an optical system for projecting the image of a reticle on the workpiece.

15

Such an immersion lithography system has been disclosed, for example, in WO99/49504, which is herein incorporated by reference for describing the general background of the technology and some general considerations. One of the issues with existing immersion lithography mechanisms is the supplying recovery of the immersion liquid. An improved system for supplying and recovering a liquid for

20

### SUMMARY OF THE INVENTION

Various liquid jet and recovery systems embodying this invention for an immersion lithography apparatus will be described below for having an image pattern projected on a workpiece such as a wafer. The image pattern is typically provided by a reticle placed on a reticle stage and projected by an optical system including an illuminator and a last-stage optical element that is disposed opposite the workpiece with a gap in between. The last-stage optical element may or may not be a lens and is hereinafter sometimes simply referred to as "the optical element." The

aforementioned gap is hereinafter referred to as "the exposure region" because the image pattern is projected onto the workpiece through this gap.

25

30

The purpose of a liquid jet and recovery system is to supply a fluid such as water into this exposure region, to entrain it there at least during the projection of the image pattern on the workpiece and to remove (or to recover) it away from the exposure region. In order to carry out the supply and recovery of the fluid quickly

and smoothly without generating air bubbles, arrays of nozzles are arranged to have their openings located proximal to the exposure region. According to one aspect of the present invention, these nozzles are each adapted to serve selectively either as a source nozzle for supplying a fluid into the exposure region or as a recovery nozzle  
5 for recovering the fluid from the exposure region. A fluid controlling device is further provided, the functions of which include causing nozzles of selected one or more of these arrays on one or more of the sides of the exposure region to serve source nozzles and causing a fluid to be supplied through them into the exposure region such that the supplied fluid contacts both the workpiece and the optical  
10 element for immersion lithography.

The fluid controlling device may be adapted also to simultaneously cause nozzles of selected one or more of the remaining arrays to serve as recovery nozzles. Since each of the nozzles can serve selectively either as a supply nozzle or a recovery nozzle, various flow patterns can be realized by this fluid controlling device. For  
15 example, the fluid may be supplied into the exposure region through the nozzles of the array on a specified side and removed through those on the array on the opposite side, the nozzles of the arrays on the remaining sides neither supplying nor recovering the fluid. As another example, the fluid may be supplied into the exposure region through the nozzles of mutually oppositely facing arrays and recovered through those  
20 of the arrays on the transversely facing arrays. As a third example, a flow in a diagonal direction may be realized if the fluid is supplied from the nozzles of two arrays on mutually adjacent and mutually perpendicular sides of the exposure region and recovered through those of the remaining arrays on the oppositely facing sides. Alternatively, the fluid may be supplied through all of the nozzles surrounding  
25 substantially all around the exposure region to have the fluid entrained inside the exposure region.

According to another aspect of the present invention, arrays of nozzles exclusively adapted to supply a fluid, herein referred to as fluid-supply nozzles, and those of nozzles exclusively adapted to recover the fluid, herein referred to as fluid-  
30 recovery nozzles, are separately provided, the fluid-supply nozzles surrounding the exposure region and the fluid-recovery nozzles surrounding the fluid-supply nozzles from all sides. According to a preferable embodiment, a groove is formed substantially all around the exposure region and the fluid-recovery nozzles are arranged to open into this groove such that a uniform flow can be more easily  
35 established. In this case, too, the fluid controlling device can establish the variety of flow patterns as explained above.

As explained above, the optical element that is disposed opposite the workpiece and comes into direct contact with the fluid such as water need not be a lens. According to a preferred embodiment of the invention, this last-stage optical element comprises a pair of optical plates contacting each other across a contact plane and having channels formed on this contact plane, these channels connecting to the exposure region such that the fluid can be passed through these channels into or out of the exposure region. This embodiment is preferred because the fluid used for immersion lithography tends to affect the material of the optical element adversely and lenses are more expensive and troublesome to replace than optical plates.

10

### BRIEF DESCRIPTION OF THE DRAWING

The invention, together with further objects and advantages thereof, may best be understood by reference to the following description taken in conjunction with the accompanying drawings in which:

15 Fig. 1 is a schematic cross-sectional view of an immersion lithography apparatus that incorporates the present invention;

Fig. 2 is a process flow diagram illustrating an exemplary process by which semiconductor devices are fabricated using the apparatus shown in Fig. 1 according to the present invention;

20 Fig. 3 is a flowchart of the wafer processing step shown in Fig. 2 in the case of fabricating semiconductor devices according to the present invention;

Fig. 4 is a schematic plan view of a liquid jet and recovery system embodying this invention that may be incorporated in the lithography apparatus of Fig. 1;

Fig. 5 is a schematic side view of the liquid jet and recovery system of Fig. 4;

25 Figs. 6-9 are schematic plan views of the liquid jet and recovery system of Figs. 4 and 5 to show various flow patterns that may be established;

Fig. 10 is a schematic plan view of another liquid jet and recovery system embodying this invention;

30 Fig. 11 is a schematic plan view of still another liquid jet and recovery system embodying this invention;

Fig. 12 is a schematic side view of the liquid jet and recovery system of Fig. 11;

Fig. 13 is a schematic side view of still another liquid jet and recovery system embodying this invention; and

5 Fig. 14 is a schematic plan view of the liquid jet and recovery system of Fig. 13.

Throughout herein, items and components that are equivalent or similar are sometimes indicated by the same numeral in different figures and may not necessarily be explained in a repetitious manner.

10

### DETAILED DESCRIPTION OF SPECIFIC EMBODIMENTS

Fig. 1 shows an immersion lithography apparatus 100 which may incorporate a liquid jet and recovery system embodying this invention but it goes without saying that this exemplary example of immersion lithography apparatus itself is not intended to limit the scope of the invention.

As shown in Fig. 1, the immersion lithography apparatus 100 comprises an illuminator optical unit 1 including a light source such as a KrF excimer laser unit, an optical integrator (or homogenizer) and a lens and serving to emit pulsed ultraviolet light IL with wavelength 248nm to be made incidence to a pattern on a reticle R. The pattern on the reticle R is projected on a wafer W coated with a photoresist at a specified magnification (such as 1/4 or 1/5) through a telecentric light projection unit PL. The pulsed light IL may alternatively be ArF excimer laser light with wavelength 193nm, F<sub>2</sub> laser light with wavelength 157nm or the i-line of a mercury lamp with wavelength 365nm. In what follows, the coordinate system with X-, Y- and Z-axes as shown in Fig. 1 is referenced to explain the directions in describing the structure and functions of the lithography apparatus 100. For the convenience of disclosure and description, the light projection unit PL is illustrated in Fig. 1 only by way of its last-stage optical element (such as a lens) 4 disposed opposite to the wafer W and a cylindrical housing 3 containing all the others of its components.

30 The reticle R is supported on a reticle stage RST incorporating a mechanism for moving the reticle R in the X-direction, the Y-direction and the rotary direction around the Z-axis. The two-dimensional position and orientation of the reticle R on the reticle stage RST are detected by a laser interferometer (not shown) in real time

and the positioning of the reticle R is effected by a main control unit 14 on the basis of the detection thus made.

The wafer W is held by a wafer holder (not shown) on a Z-stage 9 for controlling the focusing position (along the Z-axis) and the sloping tilting angle of the wafer W. The Z-stage 9 is affixed to an XY-stage 10 adapted to move in the XY-plane substantially parallel to the image-forming surface of the light projection unit PL. The XY-stage 10 is set on a base 11. Thus, the Z-stage 9 serves to match the wafer surface with the image surface of the light projection unit PL by adjusting the focusing position (along the Z-axis) and the sloping tilting angle of the wafer W by the auto-focusing and auto-leveling method, and the XY-stage 10 serves to adjust the position of the wafer W in the X-direction and the Y-direction.

The two-dimensional position and orientation of the Z-stage 9 (and hence also of the wafer W) are monitored in real time by another laser interferometer 13 with reference to a mobile mirror 12 affixed to the Z-stage 9. Control data based on the results of this monitoring are transmitted from the main control unit 14 to a stage-driving unit 15 adapted to control the motions of the Z-stage 9 and the XY-stage 10 according to the received control data. At the time of an exposure, the projection light is made to sequentially move from one to another of different exposure positions on the wafer W according to the pattern on the reticle R in a step-and-repeat routine or a step-and-scan routine.

The lithography apparatus 100 being described with reference to Fig. 1 is an immersion lithography apparatus and is hence adapted to have a liquid 7 of a specified kind such as water filling the space between the surface of the wafer W and the lower surface of the last-stage optical element 4 of the light projection unit PL at least while the pattern image of the reticle R is being copied on the wafer W.

The last-stage optical element 4 of the light projection unit PL is detachably affixed to the cylindrical housing 3. The liquid 7 is supplied from a liquid supply unit 5 that may comprise a tank, a pressure pump and a temperature regulator (not individually shown) to the space above the wafer W under a temperature-regulated condition and is collected by a liquid recovery unit 6. The temperature of the liquid 7 is regulated to be approximately the same as the temperature inside the chamber in which the lithography apparatus 100 itself is disposed. Source nozzles 21 through which the liquid 7 is supplied from the supply unit 5 and recovery nozzles 23 through which the liquid 7 is collected into the recovery unit 6 are only schematically shown. Their arrangements will be described more in detail below because they are parts of a liquid jet and recovery system to which this invention relates.

According to this invention, multiple jets are provided to inject an immersion fluid (referenced above as the liquid 7) between the wafer W to be exposed and the last-stage optical element 4 of the light projection unit PL for projecting an image pattern thereon. Figs. 4 and 5 show schematically the design of a liquid jet and recovery system 200 embodying this invention which may be incorporated in the lithography apparatus 100 described above, Fig. 5 being its horizontal side view and Fig. 4 being its plan view. The design is characterized as having a large plural number of nozzles 210 arranged in a quasi-continuous manner in arrays on all sides of the exposure area by the light projection unit PL. According to the embodiment illustrated in Fig. 4, the nozzles 210 are arranged in four arrays 211, 212, 213 and 214, each of the arrays being on one side of a rectangular formation.

Although Fig. 1 showed the source nozzles 21 connected to the liquid supply unit 5 and the recovery nozzles 23 connected to the liquid recovery unit 6 separately, it was for the convenience of illustration. The nozzles 210 shown in Figs. 4 and 5, instead, are each adapted to function both as a source nozzle and as a recovery nozzle, or, explained more precisely, to be controlled so as to function selectively either as a source nozzle or as a recovery nozzle under the control of the main control unit 14.

Figs. 6-9 show different ways in which the liquid jet and recovery system 200 of Figs. 4 and 5 may be operated. Fig. 6 shows an example wherein the wafer scan direction is as shown by an arrow and the nozzles 210 in one of the arrays (say, array 213) are controlled so as to function as source nozzles while those in the opposite array 211 are controlled so as to function as recovery nozzles, those in the remaining two arrays 212 and 214 being controlled to function neither as source nozzles nor as recovery nozzles. As a result, the flow pattern of the liquid 7 will be as shown by parallel arrows.

Fig. 7 shows another example wherein the nozzles 210 in mutually opposite arrays (say, arrays 211 and 213) are controlled so as to function as source nozzles while those in the remaining arrays 212 and 214 are controlled so as to function as recovery nozzles. The resultant flow pattern of the liquid 7 will be as shown by arcuate arrows. In other words, the wafer W may be moved in two scanning directions while the liquid 7 is directed in two orthogonal directions.

Fig. 8 shows still another example wherein all nozzles 210 in all of the arrays are controlled so as to function as source nozzles, serving to entrain the liquid 7 in the region below the projection lens of the light projection unit PL between its last-stage optical element 4 and the wafer W, the flow pattern being shown by radially outwardly pointing arrows.

Fig. 9 shows still another example wherein the nozzles 210 in two mutually adjacent arrays (say, arrays 211 and 212) are controlled so as to function as source nozzles and those in the remaining arrays 213 and 214 are controlled so as to function as recovery nozzles. The resultant flow pattern of the liquid 7 is shown by diagonal arrows.

In summary, in each of these examples, the nozzles 210 are individually controlled, or the jets are connected to valves that can be selectively set on and off as source or recovery. They may be arranged such that a single valve may control several jets together. The jets may be individual parts or integrated together as a single unit. The valve shown in Fig. 5, therefore, may be regarded as being connected to only one nozzle or to a group of nozzles. Alternatively, the nozzles may be controlled as groups. For example, group 211 may be controlled by a single valve or groups 211 and 213 may be controlled by a single valve.

Fig. 10 shows another liquid jet and recovery system 220 with an alternative arrangement characterized as providing source nozzles 225 and recovery nozzles 230 independently. In other words, unlike the system 200 shown in Figs. 4-9 with nozzles each functioning selectively either as a source nozzle or as a recovery nozzle, the system 220 shown in Fig. 10 is provided with the source nozzles 225 which are not adapted to function as a recovery nozzle and the recovery nozzles 230 which are not adapted to function as a source nozzle.

According to the example shown in Fig. 10, the source nozzles 225 and the recovery nozzles 230 are separately arranged in arrays around the exposure area, the arrays of the source nozzles 225 being each arranged inside the corresponding one of the arrays of the recovery nozzles 230. Each nozzle may be configured with a valve to turn the nozzle on or off. Alternatively, a single valve may control several jets together. Any of the flow patterns described above with reference to Figs. 6-9 can be established with the system 220 shown in Fig. 10.

Figs. 11 and 12 show still another liquid jet and recovery system 240 which is similar to the system 220 described above with reference to Fig. 10 but is different in that a liquid recovery zone 250 is provided substantially all around the exposure area. The liquid recovery zone 250 may comprise a channel cut into a supporting port or a loop made of a suitable material. Individually controllable recovery nozzles 230 are located in its interior. The zone 250 thus provided is advantageous in that the liquid 7 can be pumped out more uniformly. The source nozzles 225 may be independently controlled or used in groups, as in the embodiments explained above, to establish any of the flow patterns shown in Figs. 6-9.



In the description given above, the last-stage optical element 4 may or may not be a lens. The lower surface of this optical element 4, adapted to come into direct contact with the liquid 7, tends to become soiled as particles removed from the photoresist and the impurities contained in the liquid 7 become attached to it. For this reason, the last-stage optical element 4 may be required to be exchanged from time to time but if the element that must be replaced by a new element is a lens, the maintenance cost (or the so-called "running cost") becomes inconveniently high and it takes a longer time for the exchange.

In view of this problem, the light projection unit PL of the immersion lithography apparatus 100 may be designed such that its last-stage optical element 4 is not a lens. Figs. 13 and 14 show an example embodying this invention characterized as having a pair of mutually intimately contacting optical plates (upper plate 41 and lower plate 42) disposed below the lens 40 which would be the last-stage optical element 4 of the light projection unit PL but for these plates 41 and 42.

The embodiment of the invention shown in Figs. 13 and 14 is further characterized as integrating the liquid injection nozzle arrays with the last-stage optical element of the light projection unit PL. As shown in Figs. 13 and 14, the lower plate 42 may be provided with grooves on the upper surface so as to form liquid-passing channels 46 as the two plates 41 and 42 are attached to each other. The channels 46 each open at the lower surface, and the upper plate 41 is provided with throughholes 47 each attached to a hose 48 by way of an adaptor 49 such that the liquid 7 may be injected into and recovered from the space between the wafer W and the lower plate 42 through the channels 46, the throughholes 47 and the hoses 48.

The optical plates 41 and 42 may be of a known kind having parallel surfaces serving to correct the optical characteristics of the light projection unit PL such as its spherical aberration and coma. This embodiment is advantageous because the plates 41 and 42 are less expensive to replace than a lens. Substances such as organic silicon compounds may become attached to the surface of the optical plates 41 and 42 so as to adversely affect the optical characteristics of the light projection unit PL such as its light transmissivity and brightness as well as the uniformity of brightness on the wafer W but the user has only to replace the relatively inexpensive optical plates and the running cost would be significantly less than if the last-stage optical element 4 were a lens. The plates 41 and 42 and the lens 40 may alternatively be cemented together by using optical cements suitable for the wavelengths being used.

The liquid jet and recovery system according to this embodiment is advantageous for many reasons. Firstly, the nozzles can be set close to the exposure area. This helps to insure a continuous layer of bubble-free liquid in the exposure region. It also helps when the edge of the wafer is being exposed because the edge of the wafer is a discontinuity and may perturb the liquid layer, causing bubbles to enter the region being exposed. Secondly, the layer of liquid around the nozzles is roughly continuous and uniform, allowing for capillary action to help make certain that the liquid layer is uniform. Thirdly, the lens may be of a material such as calcium fluoride which degrades and dissolves in water while the plates may be a material such as fused silica which is stable in contact with water. Fourthly, the region between the channels is open for auxiliary optical beams. These beams may be used for through-the-lens focusing, or for other purposes.

Systems according to this invention are generally capable of providing a uniform, bubble-free layer of water between the optical element and the water. It may also improve the speed for filling the gap and removing the liquid in the outward areas of the lens or the stage areas surrounding the water. Furthermore, it will prevent degradation of the lens or the surface of the optics that may be affected by the contact with the immersion fluid.

Fig. 2 is referenced next to describe a process for fabricating a semiconductor device by using an immersion lithography apparatus incorporating a liquid jet and recovery system embodying this invention. In step 301 the device's function and performance characteristics are designed. Next, in step 302, a mask (reticle) having a pattern is designed according to the previous designing step, and in a parallel step 303, a wafer is made from a silicon material. The mask pattern designed in step 302 is exposed onto the wafer from step 303 in step 304 by a photolithography system such as the systems described above. In step 305 the semiconductor device is assembled (including the dicing process, bonding process and packaging process), then finally the device is inspected in step 306.

Fig. 3 illustrates a detailed flowchart example of the above-mentioned step 304 in the case of fabricating semiconductor devices. In step 311 (oxidation step), the wafer surface is oxidized. In step 312 (CVD step), an insulation film is formed on the wafer surface. In step 313 (electrode formation step), electrodes are formed on the wafer by vapor deposition. In step 314 (ion implantation step), ions are implanted in

the wafer. The aforementioned steps 311-314 form the preprocessing steps for wafers during wafer processing, and selection is made at each step according to processing requirements.

At each stage of wafer processing, when the above-mentioned preprocessing  
5 steps have been completed, the following post-processing steps are implemented. During post-processing, initially, in step 315 (photoresist formation step), photoresist is applied to a wafer. Next, in step 316, (exposure step), the above-mentioned exposure device is used to transfer the circuit pattern of a mask (reticle) to a wafer. Then, in step 317 (developing step), the exposed wafer is developed, and in step 318  
10 (etching step), parts other than residual photoresist (exposed material surface) are removed by etching. In step 319 (photoresist removal step), unnecessary photoresist remaining after etching is removed. Multiple circuit patterns are formed by repetition of these preprocessing and post-processing steps.

While a lithography system of this invention has been described in terms of  
15 several preferred embodiments, there are alterations, permutations, and various substitute equivalents which fall within the scope of this invention. It should also be noted that there are many alternative ways of implementing the methods and apparatuses of the present invention. It is therefore intended that the following appended claims be interpreted as including all such alterations, permutations, and  
20 various substitute equivalents as fall within the true spirit and scope of the present invention. It also goes without saying that the liquid need not be water but may be perfluoropolyether (PFPE) such as Fomblin oil used when the light source is F<sub>2</sub> laser (157nm).

WHAT IS CLAIMED IS:

1. A liquid jet and recovery system for an immersion lithography apparatus for having an image pattern projected on a workpiece through an optical element disposed opposite said workpiece, an exposure region being defined between  
5 said optical element and said workpiece, said liquid jet and recovery system comprising;

a plurality of arrays of nozzles with openings proximally located to said exposure region; and

10 a fluid controlling device for selecting those of said nozzles in one or more of said arrays on one or more of selected sides of said exposure regions to be source nozzles and causing a fluid to be supplied through said source nozzles into said exposure region such that said fluid contacts both said workpiece and said optical element for immersion lithography.

2. The system of claim 1 wherein said fluid controlling device also serves  
15 to recover said fluid from said exposure region through selected ones of the others of said nozzles.

3. The system of claim 2 wherein said fluid controlling device causes said fluid to be supplied into said exposure region through one of said arrays that is on a specified side of said exposure region and removed from said exposure region through  
20 another of said arrays on an opposite side of said exposure region.

4. The system of claim 2 wherein said fluid controlling device causes said fluid to be supplied into said exposure region through two of said arrays that are on two specified mutually perpendicular and adjacent sides of said exposure region and removed from said exposure region through the others of said arrays on opposite sides  
25 of said exposure region.

5. The system of claim 2 wherein said fluid controlling device causes said fluid to be supplied into said exposure region through two of said arrays that are on two mutually opposite specified sides of said exposure region and removed from said exposure region through the others of said arrays on the remaining sides of said  
30 exposure region perpendicular to said specified sides.

6. The system of claim 1 wherein said arrays surround substantially all around said exposure region, said fluid controlling device causing said fluid to be supplied through all of said arrays into said exposure region.

7. The system of claim 1 wherein said optical element comprises a pair of optical plates contacting each other across a contact plane and having channels formed on said contact plane, said channels connecting to said exposure region, said fluid controlling device causing said fluid to pass through said channels.

8. A liquid jet and recovery system for an immersion lithography apparatus for having an image pattern projected on a workpiece through an optical element disposed opposite said workpiece, an exposure region being defined between said optical element and said workpiece, said liquid jet and recovery system comprising;

fluid-supply arrays of nozzles with openings that surround and are proximally located to said exposure region;

fluid-recovery arrays of nozzles, surrounding said fluid-supply arrays of nozzles; and

a fluid controlling device for causing a fluid to be supplied through selected one or more of said fluid-supply arrays of nozzles into said exposure region such that said fluid contacts both said workpiece and said optical element for immersion lithography and recovering said fluid from said exposure region through selected one or more of said fluid-recovery arrays of nozzles.

9. The system of claim 8 wherein said fluid-recovery arrays of nozzles open into a groove that opens to said exposure region.

10. The system of claim 8 wherein said optical element comprises a pair of optical plates contacting each other across a contact plane and having channels formed on said contact plane, said channels connecting to said exposure region, said fluid controlling device causing said fluid to pass through said channels.

11. A method of immersion lithography for having an image pattern projected on a workpiece through an optical element disposed opposite said workpiece, an exposure region being defined between said optical element and said workpiece, said method comprising the steps of:

providing arrays of nozzles with openings proximally located to said exposure region, each of said nozzles being adapted to serve selectively either as a source nozzle or a recovery nozzle; and

5 supplying a fluid through selected ones of said arrays of nozzles into said exposure region such that said fluid contacts both said workpiece and said optical element for immersion lithography at least while said image pattern is being projected on said workpiece through said optical element.

12. The method of claim 11 further comprising the step of recovering said fluid from said exposure region through selected one of the others of said nozzles.

10 13. The method of claim 12 wherein said fluid is supplied into said exposure region through one of said arrays that is on a specified side of said exposure region and removed from said exposure region through another of said arrays on an opposite side of said exposure region.

15 14. The method of claim 12 wherein said fluid is supplied into said exposure region through two of said arrays that are on two specified mutually perpendicular and adjacent sides of said exposure region and removed from said exposure region through the others of said arrays on opposite sides of said exposure region.

20 15. The method of claim 12 wherein said fluid is supplied into said exposure region through two of said arrays that are on two mutually opposite specified sides of said exposure region and removed from said exposure region through the others of said arrays on the remaining sides of said exposure region perpendicular to said specified sides.

25 16. The method of claim 11 wherein said arrays surround substantially all around said exposure region, said fluid being supplied through all of said arrays into said exposure region.

30 17. The method of claim 11 wherein said optical element comprises a pair of optical plates contacting each other across a contact plane and having channels formed on said contact plane, said channels connecting to said exposure region, said fluid being caused to pass through said channels.

18. A method of immersion lithography for having an image pattern projected on a workpiece through an optical element disposed opposite said

workpiece, an exposure region being defined between said optical element and said workpiece, said method comprising the steps of:

fluid-supply arrays of nozzles with openings that surround from all sides and are proximally located to said exposure region;

5 fluid-recovery arrays of nozzles, surrounding said fluid-supply arrays of nozzles; and

supplying a fluid through selected one or more of said fluid-supply arrays of nozzles into said exposure region such that said fluid contacts both said workpiece and said optical element for immersion lithography and recovering said fluid from  
10 said exposure region through selected one or more of said fluid-recovery arrays of nozzles.

19. The method of claim 18 wherein said fluid-recovery arrays of nozzles open into a groove that opens to said exposure region.

20. The method of claim 11 wherein said optical element comprises a pair  
15 of optical plates contacting each other across a contact plane and having channels formed on said contact plane, said channels connecting to said exposure region, said fluid being passed through said channels.

21. An immersion lithography apparatus for having an image pattern projected on a workpiece, said immersion lithography apparatus comprising:

20 a reticle stage arranged to retain a reticle;

a working stage arranged to retain said workpiece;

a projection optical system including an illumination source and an optical element disposed opposite said workpiece for having said image pattern projected from said reticle onto said workpiece through said optical element, an exposure region  
25 being defined between said optical element and said workpiece;

arrays of nozzles with openings proximally located to said exposure region, each of said nozzles being adapted to serve selectively either as a source nozzle or a recovery nozzle; and

a fluid controlling device for selecting those of said nozzles in one or more of  
30 said arrays on one or more of selected sides of said exposure regions to be source nozzles and causing a fluid to be supplied through said source nozzles to be supplied into said exposure region such that said fluid contacts both said workpiece and said optical element for immersion lithography.

22. An immersion lithography apparatus for having an image pattern projected on a workpiece, said immersion lithography apparatus comprising:
- a reticle stage arranged to retain a reticle;
  - 5 a working stage arranged to retain said workpiece;
  - a projection optical system including an illumination source and an optical element disposed opposite said workpiece for having said image pattern projected from said reticle onto said workpiece through said optical element, an exposure region being defined between said optical element and said workpiece;
  - 10 fluid-supply arrays of nozzles with openings that surround and are proximally located to said exposure region;
  - fluid-recovery arrays of nozzles, surrounding said fluid-supply arrays of nozzles; and
  - a fluid controlling device for causing a fluid to be supplied through selected
  - 15 one or more of said fluid-supply arrays of nozzles into said exposure region such that said fluid contacts both said workpiece and said optical element for immersion lithography and recovering said fluid from said exposure region through selected one or more of said fluid-recovery arrays of nozzles.
23. An object manufactured with the immersion lithography apparatus of claim 21.
24. An object manufactured with the immersion lithography apparatus of claim 22.
25. A wafer on which an image has been formed by the immersion lithography apparatus of claim 21.
- 25 26. A wafer on which an image has been formed by the immersion lithography apparatus of claim 22.
27. A method for making an object using a lithography process, wherein the lithography process utilizes the immersion lithography apparatus of claim 21.
- 30 28. A method for making an object using a lithography process, wherein the lithography process utilizes the immersion lithography apparatus of claim 22.
29. A method for patterning a wafer using a lithography process, wherein the lithography process utilizes the immersion lithography system of claim 21.



30. A method for patterning a wafer using a lithography process, wherein the lithography process utilizes the immersion lithography system of claim 22.

31. An apparatus comprising:

a stage configured to hold a workpiece;

5 a reticle stage arranged to hold a reticle that defines an image;

a projection system including an illumination source and an optical element, the projection system configured to project the image defined by the reticle onto an exposure region on the workpiece, there being a gap between the optical element and the workpiece;

10 one or more nozzles arranged adjacent the gap, the one or more nozzles configured to either selectively provide immersion fluid into the gap or too remove immersion fluid exiting the gap.

32. The apparatus of claim 31 wherein the one or more nozzles are configured to provide the immersion fluid ahead of the projection area on the  
15 workpiece as the stage moves in a scanning direction.

33. The apparatus of claim 31 wherein the one or more nozzles are arranged in a first array of nozzles positioned ahead of the exposure area on the workpiece as the stage moves in the scanning direction.

34. The apparatus of claim 31 wherein the one or more nozzles are  
20 configured to recover the immersion fluid from the gap behind the exposure area as the workpiece on the stage moves in the scanning direction.

35. The apparatus of claim 31 wherein the one or more nozzles are arranged in a first group configured to dispense fluid into the gap and a second group configured to recovered fluid from the gap.

25 36. The apparatus of claim 35 further comprising a control system configured to control the first group of nozzles to dispense the immersion fluid into the gap and the second group to recover the immersion fluid from the gap when the workpiece on the stage is moving in a first scanning direction and to control the second group of nozzles to dispense the immersion fluid into the gap and the first  
30 group of nozzles to recover the immersion fluid from the gap when the workpiece on the stage is moving in a second scanning direction.

37. The apparatus of claim 31 wherein the one or more nozzles are arranged around the perimeter of the exposure region on the workpiece.

38. The apparatus of claim 31 wherein the one or more nozzles are arranged in concentric pattern around the exposure region, a first pattern including nozzles configured to provide the immersion fluid into the gap and a second pattern including nozzles configured to remove the immersion fluid from the gap.

5 39. The apparatus of claim 31 wherein the one or more nozzles are arranged in a first array on one side of the exposure region and a second array on an opposite side of the exposure region.

40. The apparatus of claim 31 further comprising one or more channels connected to the one or more nozzles, the channels configured to dispense the immersion fluid from the nozzles into the gap.

41. An apparatus comprising:  
a stage configured to hold a workpiece;  
a reticle stage arranged to hold a reticle that defines an image;  
a projection system including an illumination source and an optical element,  
15 the projection system configured to project the image defined by the reticle onto an exposure region on the workpiece, there being a gap between the optical element and the workpiece;

a set of source nozzles arranged adjacent the gap, the set of source nozzles configured to provide immersion fluid into the gap; and

20 a set of recovery nozzles arranged adjacent the gap, the set of recovery nozzles configured to recover immersion fluid exiting the gap.

42. The apparatus of claim 41 wherein the source nozzles are arranged on at least two sides of the exposure region.

25 43. The apparatus of claim 41 wherein the source nozzles are arranged on at least four sides of the exposure region.

44. The apparatus of claim 41 wherein the recovery nozzles are arranged on at least two sides of the exposure region.

30 45. The apparatus of claim 41 wherein the recovery nozzles are arranged on at least four sides of the exposure region.

46. The apparatus of claim 41 wherein the recovery nozzles are arranged in a first pattern around the exposure region.

47. The apparatus of claim 46 wherein the source nozzles are arranged in a second pattern around the exposure region.

48. The apparatus of claim 17 wherein the second concentric pattern of source nozzles is provided between the first pattern of recovery nozzles and the exposure region.

49. The apparatus of claim 41 further comprising a control system  
5 configured to selectively control when the source nozzles provide immersion fluid to the gap.

50. The apparatus of claim 49 wherein the control system is further configured to cause the source nozzles to provide immersion fluid ahead of the exposure region when the workpiece on the stage is scanning in a first direction.

10 51. A method of immersion lithography for having an image pattern projected on a workpiece through an optical element disposed opposite said workpiece with a gap therebetween, an exposure region being defined between said optical element and said workpiece, said method comprising the steps of:

providing one or more nozzles arranged adjacent the gap;

15 selectively either providing immersion fluid into the gap through the one or more nozzles such that the fluid contacts both the workpiece and the optical element for immersion lithography at least while the image pattern is being projected on the workpiece through the optical element or removing the immersion fluid exiting the gap.

20 52. The method of claim 51 wherein the one or more nozzles are configured to provide the immersion fluid ahead of the projection area on the workpiece as the stage moves in a scanning direction.

53. The method of claim 51 wherein the one or more nozzles are arranged in a first array of nozzles positioned ahead of the exposure area on the workpiece as  
25 the stage moves in the scanning direction.

54. The method of claim 51 wherein the one or more nozzles are configured to recover the immersion fluid from the gap behind the exposure area as the workpiece on the stage moves in the scanning direction.

55. The method of claim 51 wherein the one or more nozzles are arranged  
30 in a first group configured to dispense fluid into the gap and a second group configured to recover fluid from the gap.

56. The apparatus of claim 55 further comprising a control system configured to control the first group of nozzles to dispense the immersion fluid into the gap and the second group to recover the immersion fluid from the gap when the

workpiece on the stage is moving in a first scanning direction and to control the second group of nozzles to dispense the immersion fluid into the gap and the first group of nozzles to recover the immersion fluid from the gap when the workpiece on the stage is moving in a second scanning direction.

5           57.     The method of claim 51 wherein the one or more nozzles are arranged around the perimeter of the exposure region on the workpiece.

          58.     The method of claim 51 wherein the one or more nozzles are arranged in concentric pattern around the exposure region, a first pattern including nozzles configured to provide the immersion fluid into the gap and a second pattern including  
10           nozzles configured to remove the immersion fluid from the gap.

          59.     The method of claim 51 wherein the one or more nozzles are arranged in a first array on one side of the exposure region and a second array on an opposite side of the exposure region.

          60.     The method of claim 51 further comprising one or more channels  
15           connected to the one or more nozzles, the channels configured to dispense the immersion fluid from the nozzles into the gap.

          61.     A method of immersion lithography for having an image pattern projected on a workpiece through an optical element disposed opposite said workpiece with a gap therebetween, an exposure region being defined between said  
20           optical element and said workpiece, said method comprising the steps of:  
              providing a set of source nozzles arranged adjacent the gap;  
              providing a set of recovery nozzles arranged adjacent the gap;  
              supplying a fluid into the gap through the set of source nozzles such that the fluid contacts both the workpiece and the optical element for immersion lithography  
25           at least while the image pattern is being projected on the workpiece through the optical element; and  
              recovering the immersion fluid exiting the gap through the set of recovery nozzles.

          62.     The method of claim 61 wherein the source nozzles are arranged on at  
30           least two sides of the exposure region.

          63.     The method of claim 61 wherein the source nozzles are arranged on at least four sides of the exposure region.

          64.     The method of claim 61 wherein the recovery nozzles are arranged on at least two sides of the exposure region.

65. The method of claim 61 wherein the recovery nozzles are arranged on at least four sides of the exposure region.

66. The method of claim 61 wherein the recovery nozzles are arranged in a first pattern around the exposure region.

5 67. The method of claim 66 wherein the source nozzles are arranged in a second pattern around the exposure region.

68. The method of claim 67 wherein the second concentric pattern of source nozzles is provided between the first pattern of recovery nozzles and the exposure region.

10 69. The method of claim 61 further comprising a control system configured to selectively control when the source nozzles provide immersion fluid to the gap.

70. The apparatus of claim 69 wherein the control system is further configured to cause the source nozzles to provide immersion fluid ahead of the exposure region when the workpiece on the stage is scanning in a first direction.

71. The apparatus of claim 31 further comprising one or more grooves providing fluid communication between the immersion fluid and the one or more nozzles respectively.

20 72. The apparatus of claim 41 further comprising one or more grooves providing fluid communication between the immersion fluid and the one or more nozzles respectively.

73. The method of claim 51 wherein the removing the immersion fluid exiting the gap further comprises removing the fluid through one or more grooves providing fluid communication between the immersion fluid and the one or more nozzles.

74. The method of claim 61 further providing grooves in fluid communication between the immersion fluid and the recovery nozzles.

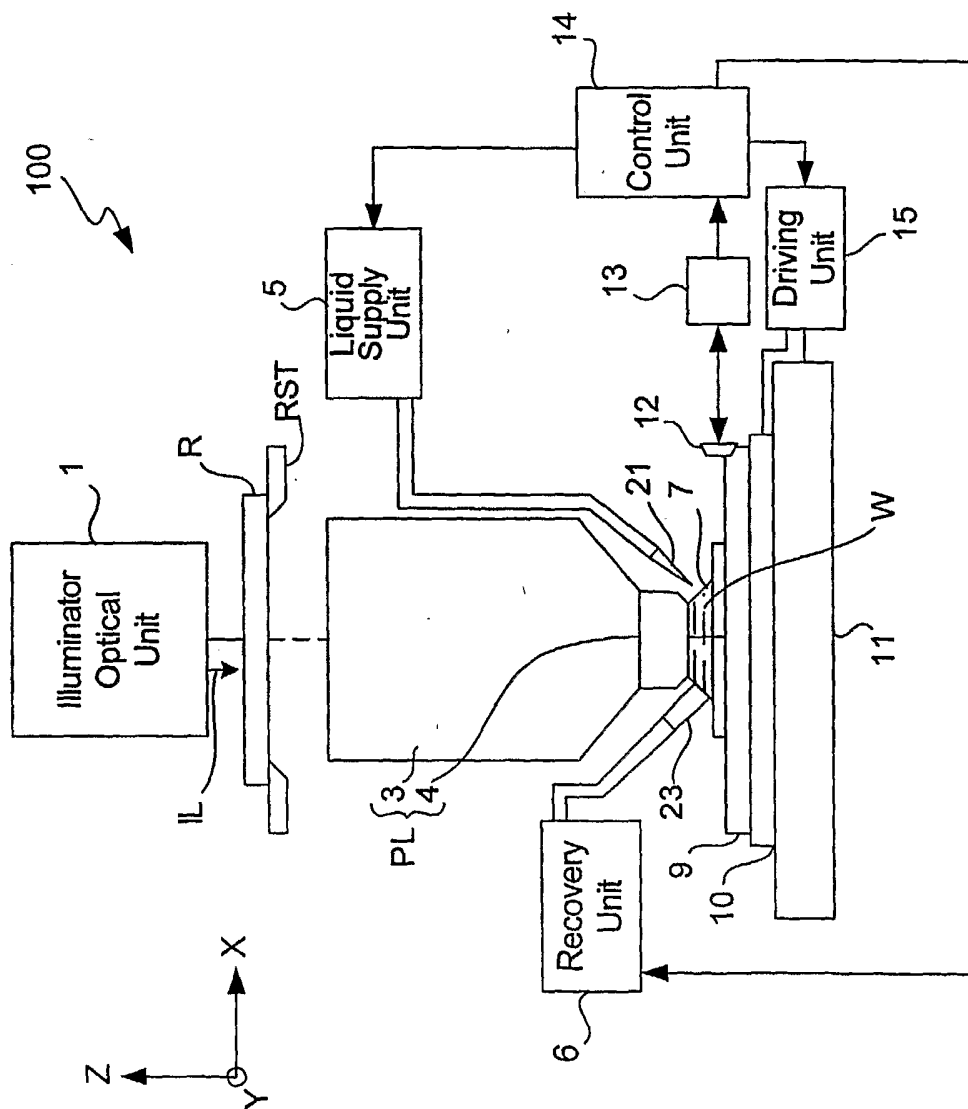
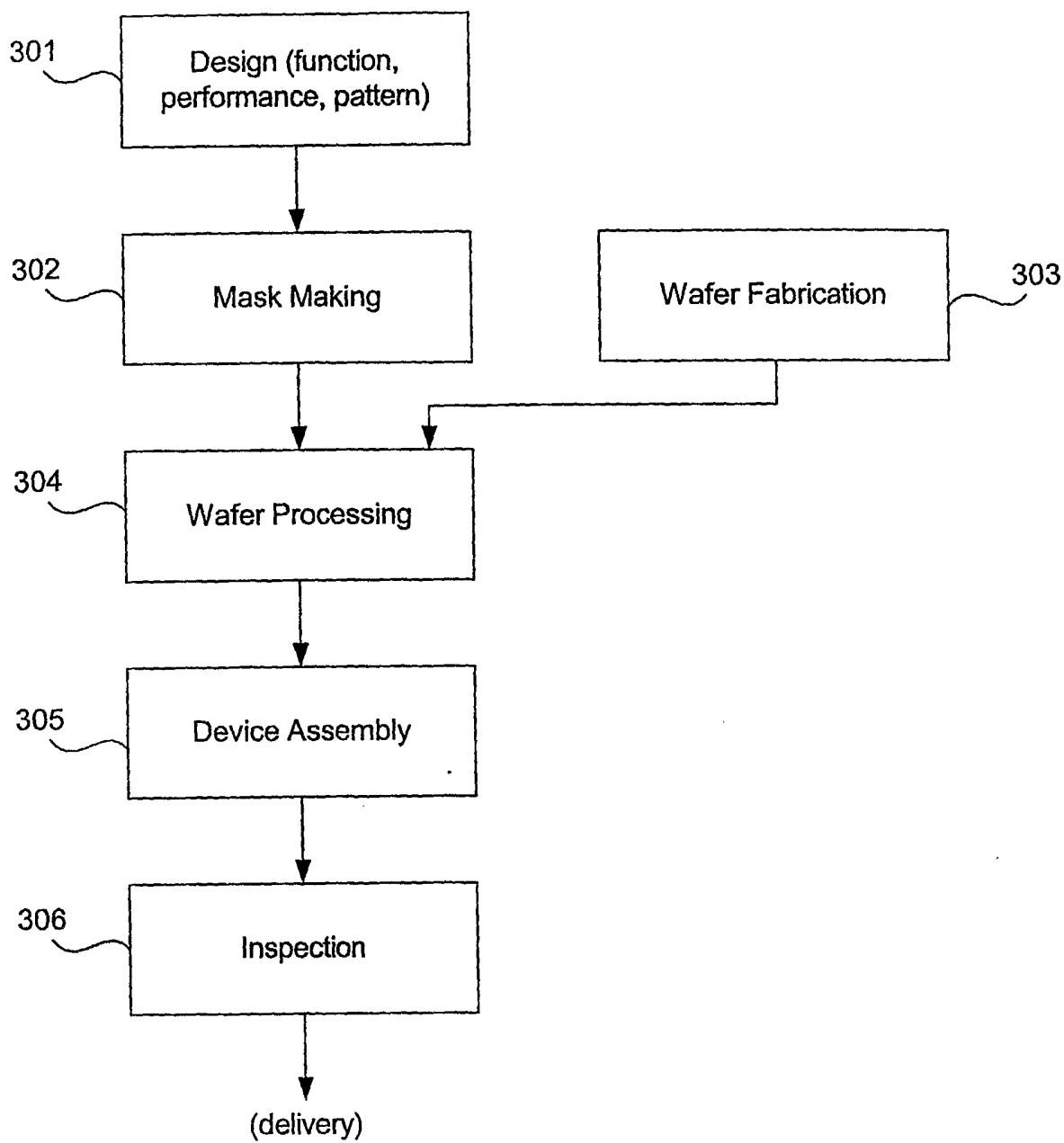
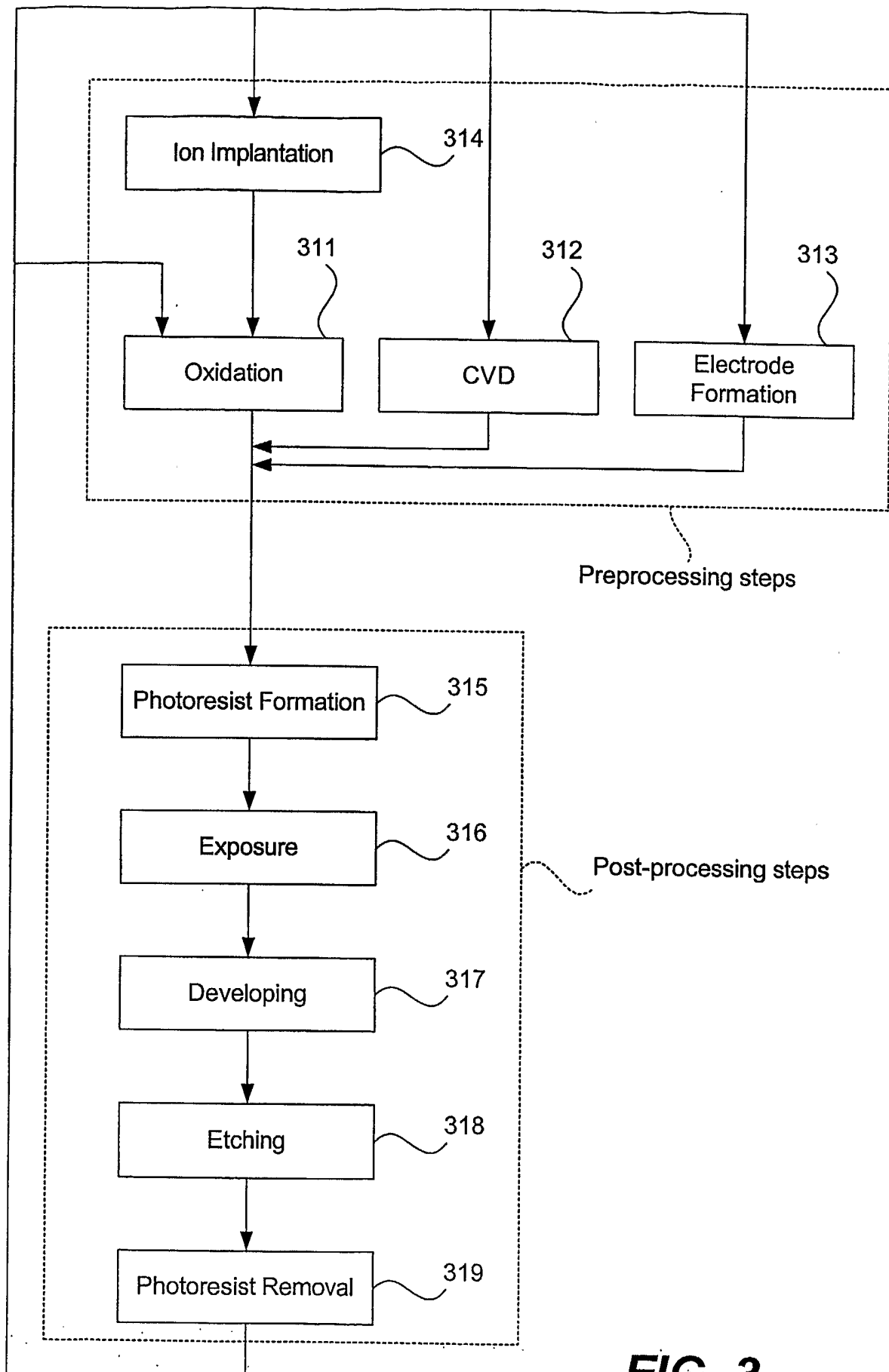


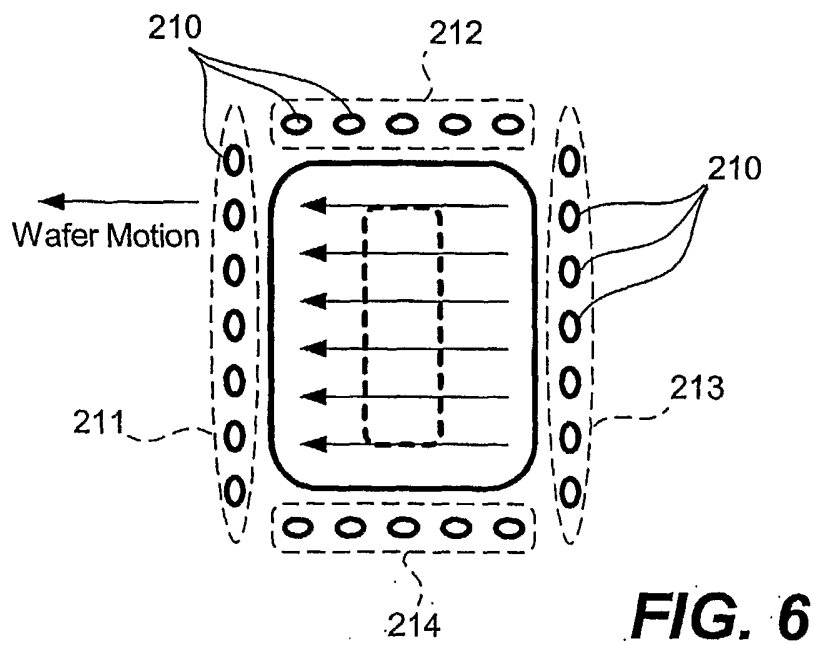
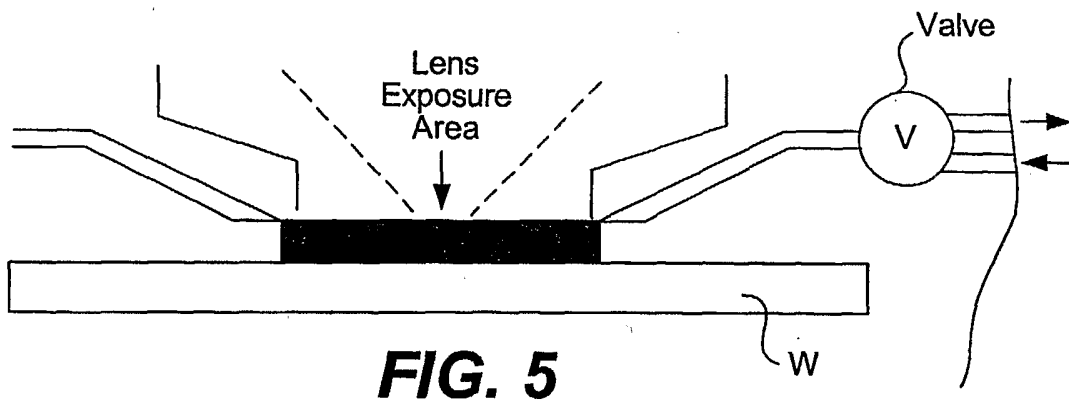
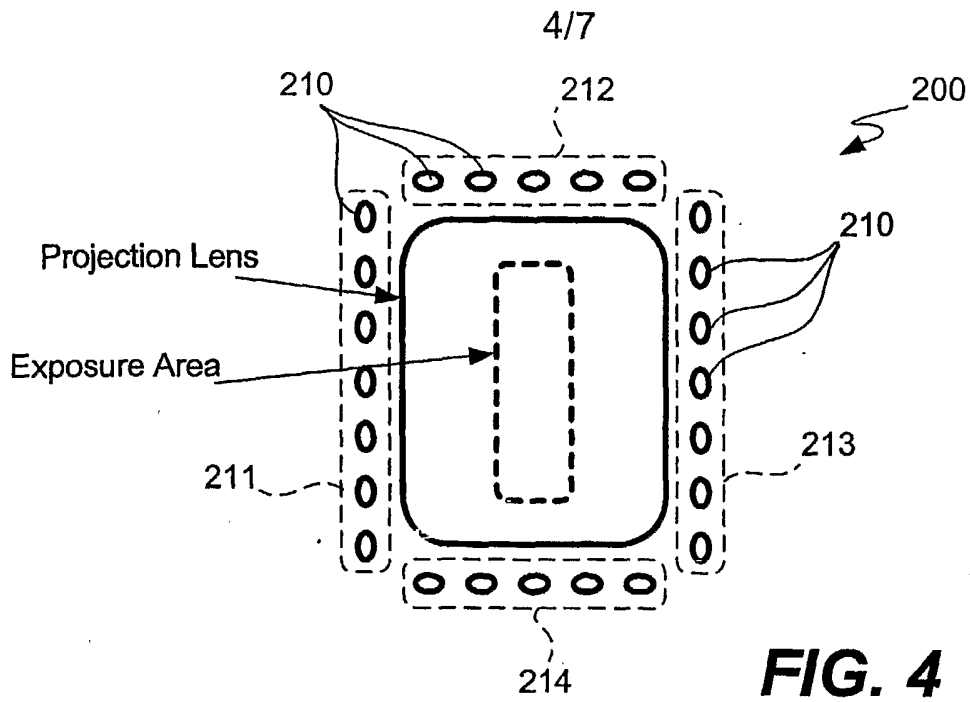
FIG. 1

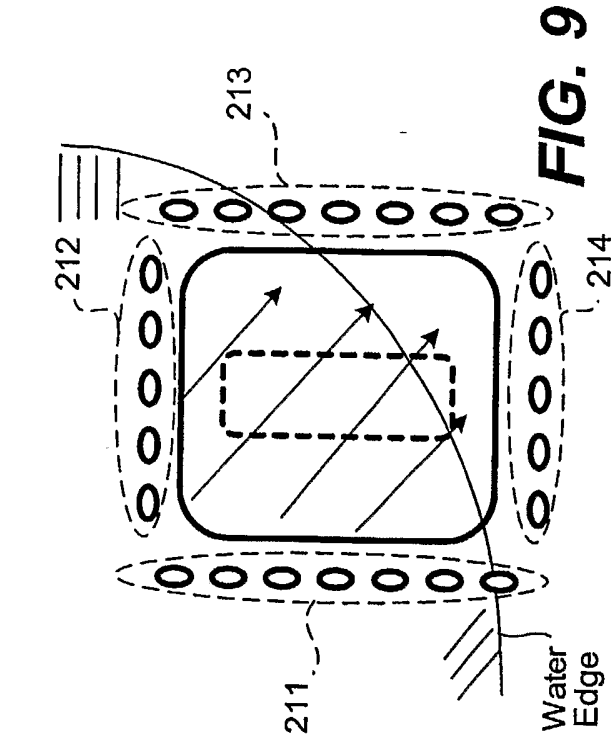




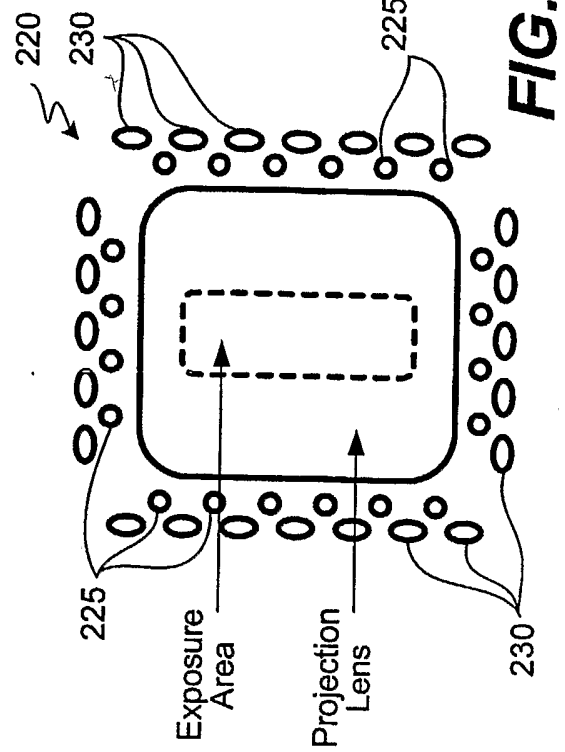
**FIG. 3**



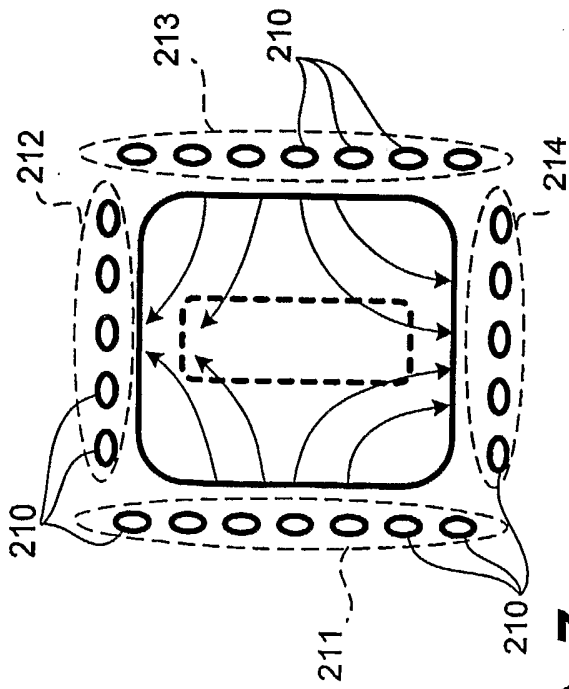




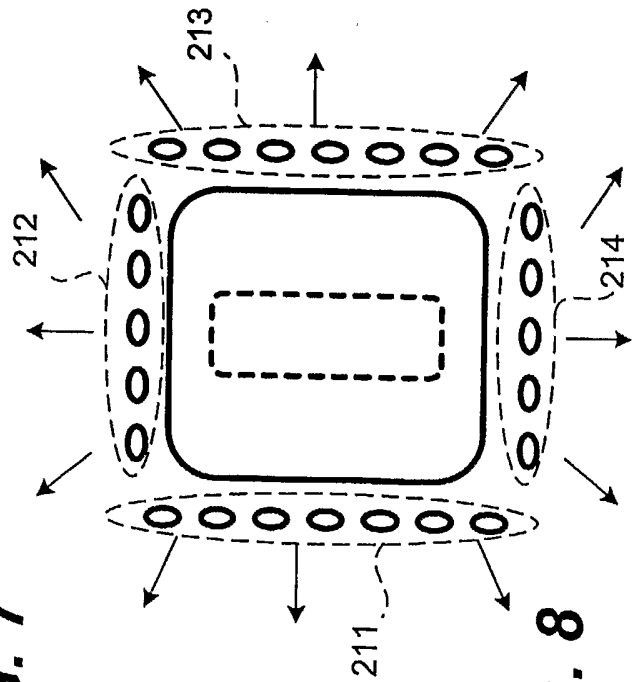
**FIG. 9**



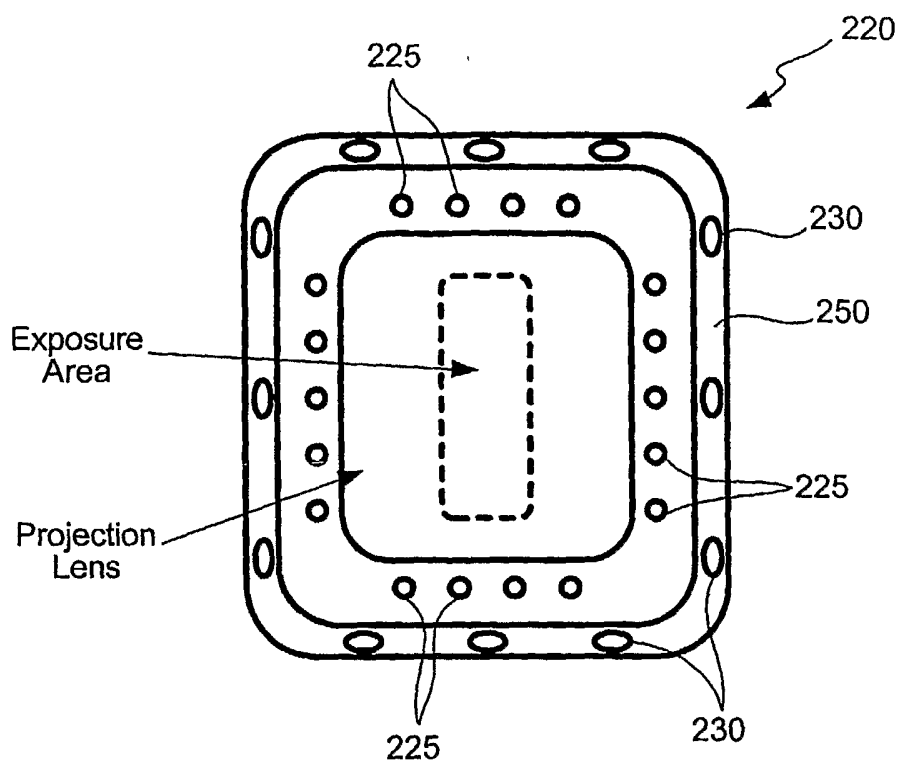
**FIG. 10**



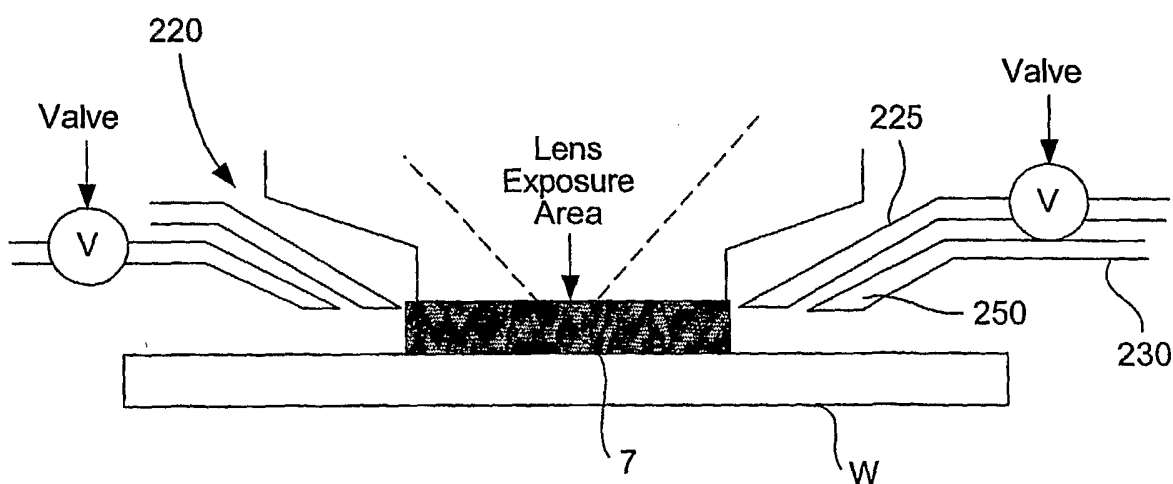
**FIG. 7**



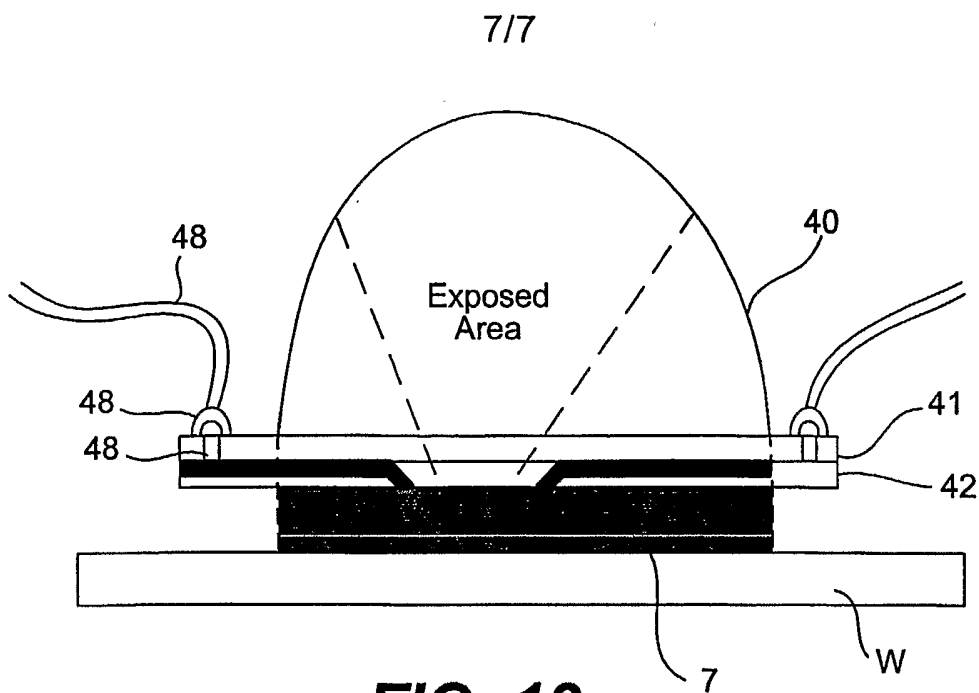
**FIG. 8**



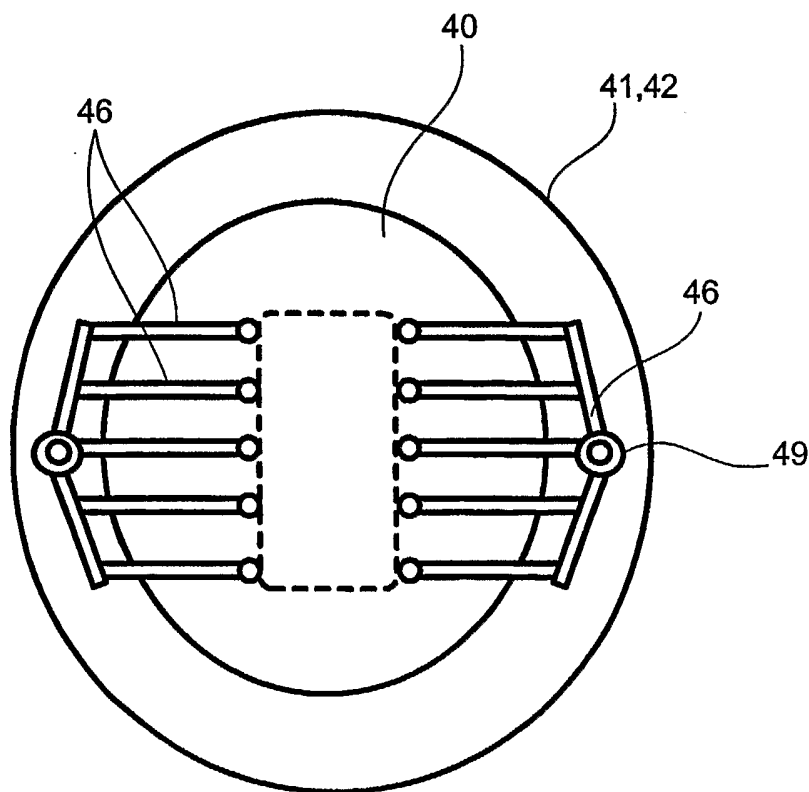
**FIG. 11**



**FIG. 12**



**FIG. 13**



**FIG. 14**