

No. 673,602.

Patented May 7, 1901.

J. H. FOX.
DIFFERENTIAL PUMP.
(Application filed Mar. 5, 1900.)

2 Sheets—Sheet 1.

(No Model.)

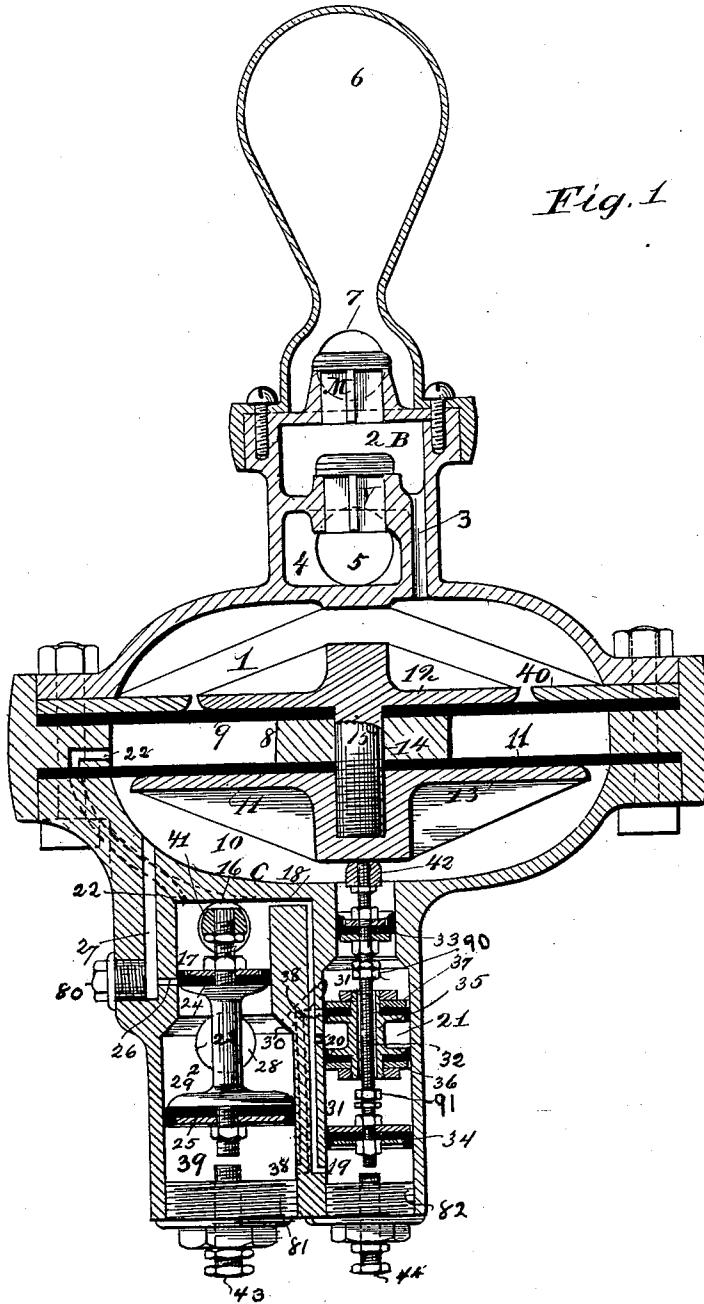

Fig. 1

Witnesses
Jas. A. Jensen.
C. H. Olds

Inventor
John H. Fox
by Wm. M. Morrow
Attorney.

No. 673,602.

Patented May 7, 1901.

J. H. FOX.
DIFFERENTIAL PUMP.

(Application filed Mar. 5, 1900.)

(No Model.)

2 Sheets—Sheet 2.

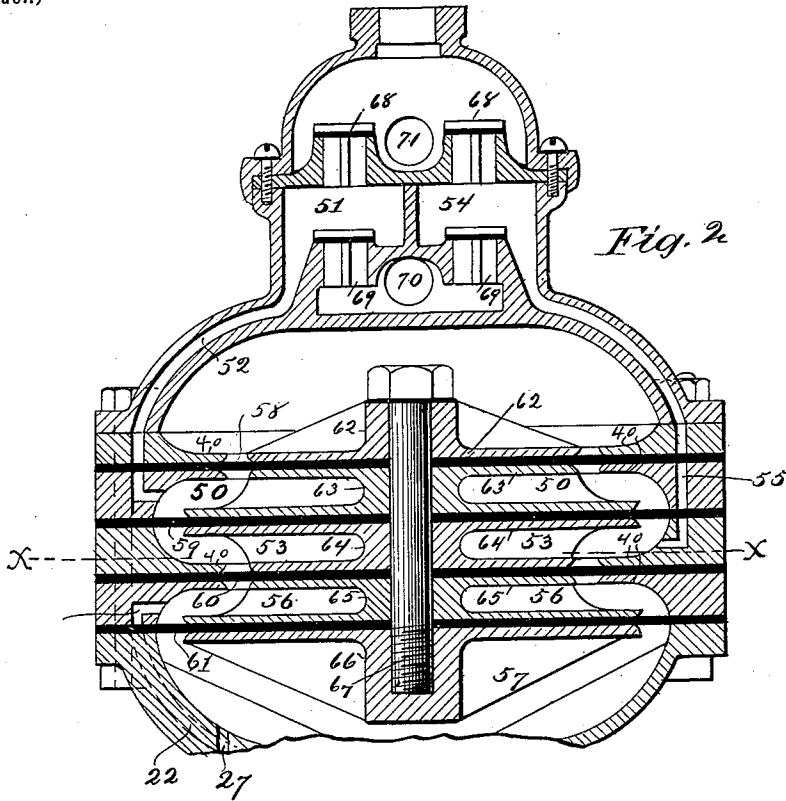

Fig. 2

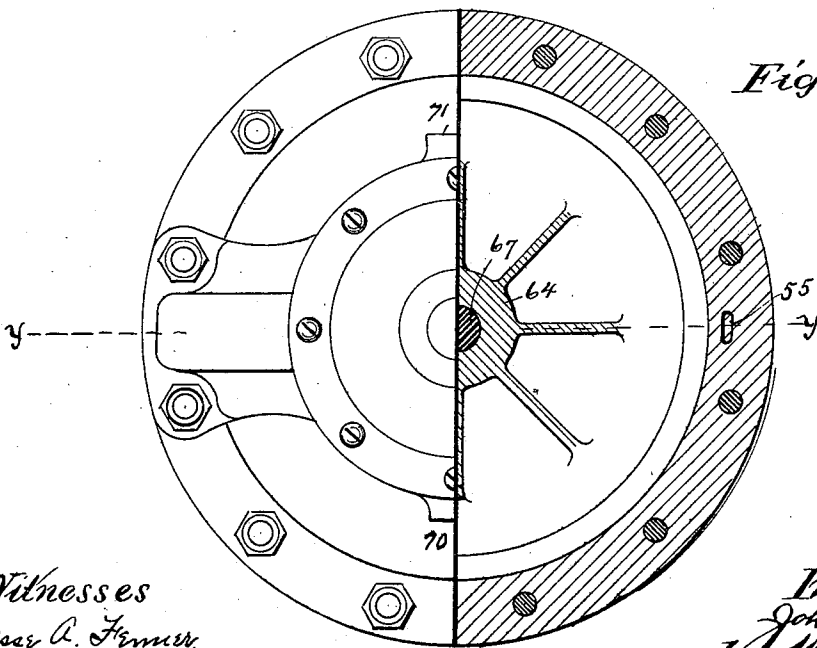

Fig. 3.

Witnesses
Jacob A. Fenner
C. H. Olds

Inventor
John H. Fox
by Wm. M. Moore
Attorney

UNITED STATES PATENT OFFICE.

JOHN H. FOX, OF CLEVELAND, OHIO, ASSIGNOR OF TWO-FIFTHS TO
CHARLES L. WILKINS, OF COLUMBUS, OHIO.

DIFFERENTIAL PUMP.

SPECIFICATION forming part of Letters Patent No. 673,602, dated May 7, 1901.

Application filed March 5, 1900. Serial No. 7,355. (No model.)

To all whom it may concern:

Be it known that I, JOHN H. FOX, a citizen of the United States, and a resident of Cleveland, county of Cuyahoga, State of Ohio, have
5 invented certain new and useful Improvements in Differential Pumps, of which I hereby declare the following to be a full, clear, and exact description, such as will enable others skilled in the art to which it apper-
10 tains to make and use the same.

My invention relates to diaphragm fluid pumps or compressors designed to be actuated by a supply of motive fluid, either gaseous or liquid, under pressure, whereby the
15 motor of the machine is automatically started and stopped, forcing the fluid through the pump or compressor of the machine.

The machine is especially adapted to elevating water by means of hydrostatic or pneumatic pressure or to increasing the pressure of the water from city mains, but the invention includes the pumping or compressing of any fluid, any fluid also being used to drive the motor. For convenience in the following description water will be assumed to be the motive fluid and the fluid pumped.

My invention consists in the combination and arrangement of the various parts and in the construction of details, as hereinafter described, shown in the accompanying drawings, and specifically pointed out in the claims.

In the drawings, Figure 1 is a vertical sectional view of the single-acting differential diaphragm motor pump or compressor. Fig. 2 is a vertical sectional view of the pump or compressor end of the double-acting differential diaphragm motor pump or compressor on line *yy*, Fig. 3; and Fig. 3 is a plan view
40 of the same, one-half of the view being in horizontal section on line *xx*, Fig. 2.

The motor end of the double-acting machine is like that of the single-acting machine.

Like parts are referred to by the same reference characters throughout the several views.

The single-acting differential diaphragm motor pump or compressor consists of the following: A pump-chamber 1, Fig. 1, is in communication with the chamber 2 through the opening 3. When the valve V is lifted, 2 is in communication with 4 and the supply or

suction pipe 5. When the valve M is lifted, 2 is in communication with the air-chamber 6 and the delivery-pipe 7. The chamber 1 is separated from chamber 8 by the flexible
55 diaphragm 9, and chamber 8 is separated from chamber 10 by the flexible diaphragm 11, the edges of the diaphragms being securely clamped to the body of the machine by the rings and bolts, as shown in Fig. 1. The two diaphragms are firmly clamped together in the center by the disks or plates 12 and 13, the separator 14, and the bolt 15, which may be made a part of one of the disks, as shown in Fig. 1, or separate from them, as
65 in Fig. 2. Thus the diaphragms are free to vibrate in a direction perpendicular to their plane. It is evident that when the diaphragm 9 is lowered the volume of 1 will be increased, producing a suction and causing water to flow
70 in through 5, and when the diaphragm 9 is raised the volume of 1 will be decreased, thereby forcing water out through 7.

The motive or live water is admitted through 16, which is in communication with chamber 17, and through the port 18 with chamber 19, through ports 18 and 20 with chamber 21, and through port 22 with chamber 8.

The main valve 23 is a differential valve consisting of two pistons provided with cup-leathers 24 and 25, of different diameters, held together by supporting screws or nuts, as shown in Figs. 1 and 2, and is free to move vertically. When the valve 23 is lowered, the chamber 17 is put in communication with chamber 10 through ports 26 and 27. The exhaust 28 is in communication with chamber 29 and through the port 30 with chamber 31. When valve 23 is raised, chamber 29 is put in communication with chamber 10
90 through ports 26 and 27.

The auxiliary valve consists of a differential valve 32, provided with cup-leather pistons 33 and 34 of different diameters. The valve 35 is provided with two cup-leathers 36 and 37 of equal diameter and is free to move up and down on the stem of valve 32, its motion being controlled by the tappet-nuts 90 and 91 on the valve-stem. The cup-leathers 36 and 37 need not be of same diameter as valve 34, as shown. In place of any or all of the cup-leathers rubber, cloth-inserted rubber,

metal, or other material may be used. When valve 35 is raised so that 37 is above port 38, chamber 39 is in communication with the live-water pipe through port 38, chamber 21, ports 20 and 18, and chamber 17. When the valve 35 is lowered so that the piston 37 is below port 38, 39 is in communication with the exhaust-pipe through port 38, chamber 31, port 30, and chamber 29. Nuts 41 and 42 and set-screws 43 and 44 are for adjusting the motions of the valves 23 and 32.

The action of the motor may be described as follows: The motive water is admitted through inlet and fills the chamber 17, port 22, chamber 8, port 18, chamber 19, port 20, and chamber 21. The pressure of motive water acting on lower end of valve 32 raises valve 32 and holds it firmly against disk 13. The pressure of motive water acting on upper end of valve 23 forces it down, the cup-leather 24 uncovering the port 26, thus admitting motive water to 10. The pressure is the same on the two sides of the diaphragm 11, the forces acting on this diaphragm counteracting one another; but the pressure of motive water acting on lower side of diaphragm 9 the combined effect is to force the two diaphragms up with a force dependent upon the free or effective area of 9—that is, the area within the inside circumference of ring 40. As disk 13 moves upward valve 32 follows and lifts valve 35 until the port 38 is uncovered to the chamber 21, thus admitting live or motive water to chamber 39. The area of the lower end of valve 23 being greater than the area of its upper end, the valve is forced up, cutting off port 26 from chamber 17 and opening port 26 to chamber 29, thus putting chamber 10 in communication with the exhaust-pipe. A ring 40 is inserted above diaphragm 9, making the free or effective area of 9 less than that of 11. Therefore when the lower side of 11 is relieved of pressure the two diaphragms are forced down with a force whose magnitude depends upon the difference in the effective areas of 9 and 11. As disk 13 is lowered valve 32 is forced down, finally striking and forcing valve 35 down until port 38 is cut off from chamber 21 and opened to chamber 31, thus putting chamber 39 in communication with the exhaust-pipe. The lower end of valve 23 being relieved of pressure, the valve is forced down, cutting off the port 26 from chamber 29 and again putting chamber 10 in communication with chamber 17 through ports 26 and 27.

The rings 40 are made of various sizes with regard to the inside diameter, the particular size used depending upon the amount of suction desired.

The area of the lower end of valve 32 being greater than the area of its upper end, it will be held up against disk 13 whenever live water is in chamber 19.

The motor end of the double-acting differential diaphragm motor pump or compressor

is the same as the motor of the single-acting machine described above.

The double-acting pump or compressor consists of the following arrangements and constructions of parts: Pump-chamber 50, Fig. 2, is in communication with chamber 51 through port 52, and chamber 53 is in communication with 54 through the port 55. Chambers 50, 53, 56, and 57 are inclosed and separated from one another by the flexible diaphragms 58, 59, 60, and 61, as shown in Fig. 2, the effective areas of 59 and 61 being greater than those of 58 and 60, the area of 58 being preferably equal to that of 60. The diaphragms are secured to the body of the machine by the rings and bolts, as shown, and clamped together in the middle between the disks 62, 63, 64, 65, and 66 by means of bolt 67. It is evident that when the diaphragms are forced upward the volume of chamber 50 will be decreased and the volume of 53 will be increased, thereby forcing water out of the chamber 50 and causing water to flow into the chamber 53 by suction. The arrangement and action of the lift-valves 68 68 and 69 69 are evident without further description.

70 is the suction-pipe, and 71 is the delivery-pipe.

The area (free or effective area) of disk 61 should preferably be twice that of 60 and area of 60 equal to that of 58. The area of 59 depends upon the pressure desired in the delivery-pipe 71. Thus if a suction of ten pounds per square inch in 70 and a pressure of twenty pounds per square inch (above atmospheric pressure) in 71 are desired, the motive water having a pressure of thirty pounds per square inch above atmospheric pressure and exhaust-pressure equal to atmospheric pressure, we have area of diaphragm 59 equal area of 61, equal to twice the area of 58, and equal to twice the area of 60, the friction of the machine being regarded as zero. Therefore any desired pressure may be obtained in the delivery-pipe by proportioning accordingly.

The diaphragms may be made of cloth-inserted rubber, rubber, leather, rawhide, or similar material or of thin corrugated disks of steel, brass, bronze, copper, or similar metal.

The arrangement of the ports 52 and 55 with respect to the diaphragms may be changed without materially affecting the working and design of the machine. Thus, for example, port 22 may open into chamber 50 instead of 56 and port 52 into chamber 56 instead of 50.

In Fig. 1 port 26 may consist of a single opening or a horizontal row of small openings, the latter design being used to prevent the cup-leather 24 from being forced into the opening.

The plug 80 makes the ports 26 and 27 easily accessible, and the plugs 81 and 82 make the removal of valves 23 and 32 an easy matter.

The advantages of this device are obvious. It will be seen that the friction is reduced to a minimum, and there are no stuffing-boxes or guides to get out of order, and no leakage is possible. The wearing qualities also are very great, since the flexible diaphragms yield gently to the pressure and cushion the stroke. Therefore there is no water-hammer or shock to the apparatus. Again, the hydrant or other motive fluid cannot come in contact with the fluid pumped by the machine.

I believe myself to be the first to provide a pump-action by means of diaphragms of different areas, including between them a chamber with motive fluid under constant pressure.

Having described my invention, what I claim as new, and desire to secure by Letters Patent, is—

1. In a differential diaphragm-pump, the combination with a sectional chamber, provided with a motor end and a pumping-head, of diaphragms secured transversely across said chamber between said sections, central disks secured to said diaphragms, the said disks being of different diameters, a separator between said disks, an annular ring about the margin of one of the diaphragms, an inlet-passage to the chamber between the diaphragms for fluid under pressure, and an inlet and outlet opening from said motor end to the side of one of the diaphragms, inlet and outlet openings to the motor end, and valves in said motor end to alternately admit said fluid to said diaphragm and to withdraw it therefrom, whereby the said diaphragms are given a reciprocating movement, substantially as described.

2. In a device for the purpose described the combination with reciprocating diaphragms inclosed in a chamber of means for alternately and automatically admitting and exhausting

motive fluid from contact with one of said diaphragms, consisting of a main differential valve, a valve-chamber, outlet and inlet ports to said valve-chamber, a port arranged to serve alternately as inlet and exhaust to and from said diaphragm-chamber, an auxiliary differential valve adapted to move in unison with said diaphragms, a change-valve sleeved upon the stem of said auxiliary valve, a valve-chamber in which the auxiliary valve moves and passages connecting said chambers, whereby motive fluid is conducted to said valves to reverse their movements, substantially as described.

3. In a diaphragm fluid-pump, actuated by motive fluid, the combination with a chamber, of flexible diaphragms secured transversely across said chamber including between them a chamber constantly filled with motive fluid under pressure, a ring about the margin of one of the diaphragms, arranged to limit its area, central disks of different sizes secured to said diaphragms and extending over the effective area of said diaphragms—a separator between said disks, means for admitting to and withdrawing from the side of the diaphragm of largest effective area the motive fluid, whereby the diaphragms are reciprocated, and a pumping-chamber adjacent to said diaphragms and inlet and outlet valves connected therewith, whereby fluid will be drawn into the pumping-chamber and expelled therefrom with each reciprocation of the diaphragm substantially as described.

In testimony whereof I have signed my name to this specification in the presence of two subscribing witnesses.

JOHN H. FOX.

Witnesses:

JESSE A. FENNER,
WM. M. MONROE.