



(86) Date de dépôt PCT/PCT Filing Date: 2016/01/15
 (87) Date publication PCT/PCT Publication Date: 2016/07/21
 (85) Entrée phase nationale/National Entry: 2017/06/08
 (86) N° demande PCT/PCT Application No.: US 2016/013558
 (87) N° publication PCT/PCT Publication No.: 2016/115438
 (30) Priorité/Priority: 2015/01/16 (US62/104,194)

(51) Cl.Int./Int.Cl. *G01N 1/22* (2006.01),
G08B 21/12 (2006.01)
 (71) Demandeur/Applicant:
INDUSTRIAL SCIENTIFIC CORPORATION, US
 (72) Inventeurs/Inventors:
BELSKI, TIMOTHY J., US;
BRENSTUHL, RODNEY DAVID, US;
FUTRELL, JOSHUA ALLEN, US;
HUGHES, CHARLES DENNIS, US;
MIKULIN, THOMAS MICHAEL, US;
SUWALSKI, HENRY J., US;
TIMCO, DANIEL JAMES, US
 (74) Agent: BORDEN LADNER GERVAIS LLP

(54) Titre : SYSTEME MODULAIRE POUR LA SURVEILLANCE DE GAZ
 (54) Title: MODULAR GAS MONITORING SYSTEM

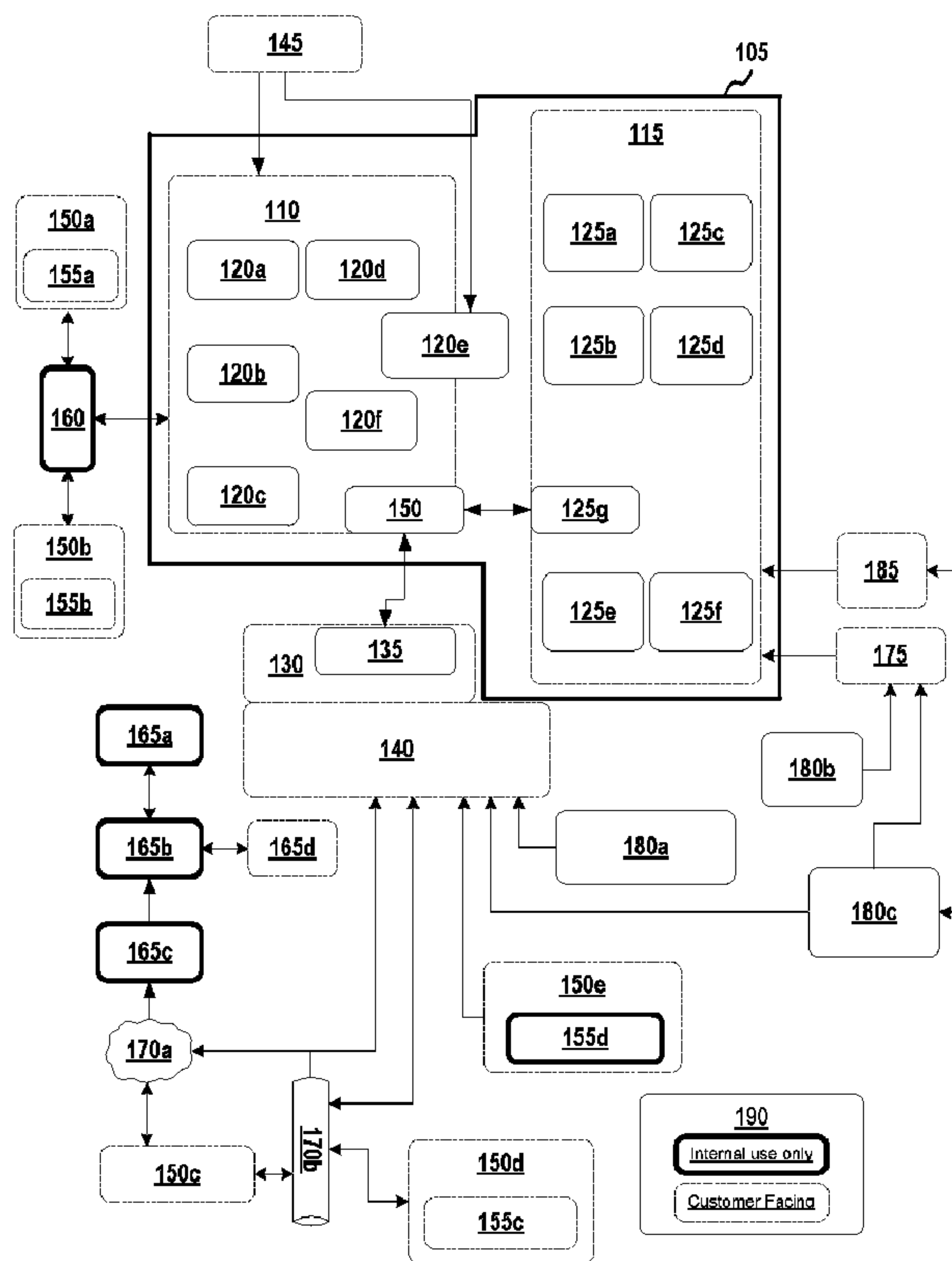

FIG. 1

(57) Abrégé/Abstract:

Monitoring systems and apparatuses and methods for using same are generally described. A gas monitoring system may include a base component and a module component. The module may be configured to be operably coupled to the base component

(57) **Abrégé(suite)/Abstract(continued):**

through corresponding interface connectors. The system may be monitor for gases and generate alarms relating thereto, when the module is connected to the base. The base and/or module may have limited or no functionality when disconnected from the module and/or base. The module may include components that typically have an increased potential for upgrades, replacement, maintenance, or other modifications. The base may include components that typically have a lower rate of being upgraded, replaced, or requiring maintenance. In this manner, high maintenance components may be arranged in a module that has a smaller and more portable form factor as compared to the base and the system overall.

(12) INTERNATIONAL APPLICATION PUBLISHED UNDER THE PATENT COOPERATION TREATY (PCT)

(19) World Intellectual Property
Organization
International Bureau(10) International Publication Number
WO 2016/115438 A1(43) International Publication Date
21 July 2016 (21.07.2016)

(51) International Patent Classification:

G01N 1/22 (2006.01) G08B 21/12 (2006.01)

(21) International Application Number:

PCT/US2016/013558

(22) International Filing Date:

15 January 2016 (15.01.2016)

(25) Filing Language:

English

(26) Publication Language:

English

(30) Priority Data:

62/104,194 16 January 2015 (16.01.2015) US

(71) Applicant: INDUSTRIAL SCIENTIFIC CORPORATION [US/US]; 1 Life Way, Pittsburgh, Pennsylvania 15205-7500 (US).

(72) Inventors: BELSKI, Timothy, J.; Washington, Pennsylvania 15301 (US). BRENSTUHL, Rodney, David; Amsterdam, Ohio 43903 (US). FUTRELL, Joshua, Allen; Pittsburgh, Pennsylvania (US). HUGHES, Charles, Dennis; Moon Township, Pennsylvania 15108 (US).

MIKULIN, Thomas, Michael; New Wilmington, Pennsylvania 16142 (US). SUWALSKI, Henry, J.; Cranberry Township, Pennsylvania 16066 (US). TIMCO, Daniel, James; McDonald, Pennsylvania 15057 (US).

(74) Agents: MONOCELLO, John, A., III et al.; GTC Law Group PC & Affiliates, c/o CPA Global, 900 Second Avenue South, Suite 600, Minneapolis, Minnesota 55402 (US).

(81) Designated States (unless otherwise indicated, for every kind of national protection available): AE, AG, AL, AM, AO, AT, AU, AZ, BA, BB, BG, BH, BN, BR, BW, BY, BZ, CA, CH, CL, CN, CO, CR, CU, CZ, DE, DK, DM, DO, DZ, EC, EE, EG, ES, FI, GB, GD, GE, GH, GM, GT, HN, HR, HU, ID, IL, IN, IR, IS, JP, KE, KG, KN, KP, KR, KZ, LA, LC, LK, LR, LS, LU, LY, MA, MD, ME, MG, MK, MN, MW, MX, MY, MZ, NA, NG, NI, NO, NZ, OM, PA, PE, PG, PH, PL, PT, QA, RO, RS, RU, RW, SA, SC, SD, SE, SG, SK, SL, SM, ST, SV, SY, TH, TJ, TM, TN, TR, TT, TZ, UA, UG, US, UZ, VC, VN, ZA, ZM, ZW.

(84) Designated States (unless otherwise indicated, for every kind of regional protection available): ARIPO (BW, GH,

[Continued on next page]

(54) Title: MODULAR GAS MONITORING SYSTEM

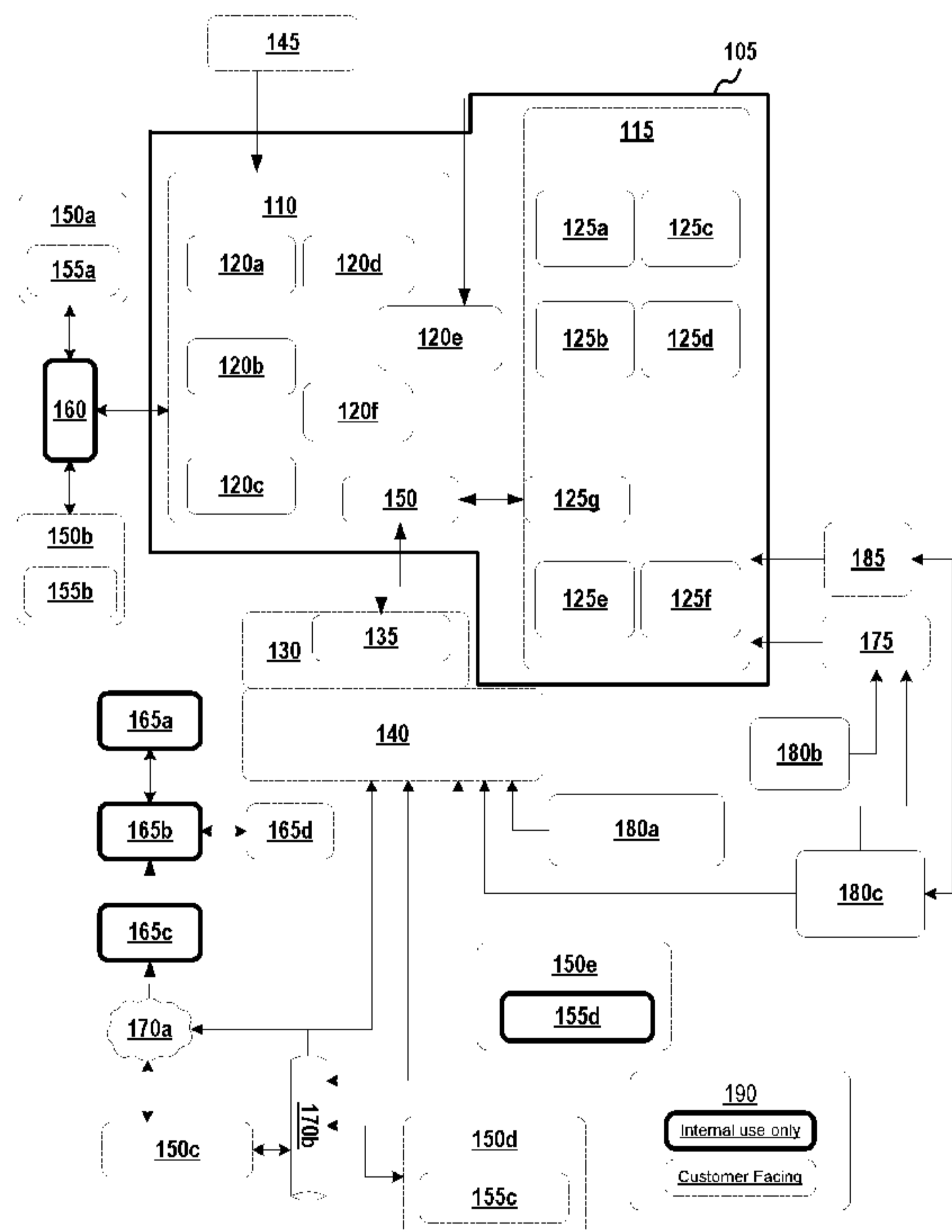

FIG. 1

(57) Abstract: Monitoring systems and apparatuses and methods for using same are generally described. A gas monitoring system may include a base component and a module component. The module may be configured to be operably coupled to the base component through corresponding interface connectors. The system may be monitor for gases and generate alarms relating thereto, when the module is connected to the base. The base and/or module may have limited or no functionality when disconnected from the module and/or base. The module may include components that typically have an increased potential for upgrades, replacement, maintenance, or other modifications. The base may include components that typically have a lower rate of being upgraded, replaced, or requiring maintenance. In this manner, high maintenance components may be arranged in a module that has a smaller and more portable form factor as compared to the base and the system overall.

WO 2016/115438 A1



GM, KE, LR, LS, MW, MZ, NA, RW, SD, SL, ST, SZ,
TZ, UG, ZM, ZW), Eurasian (AM, AZ, BY, KG, KZ, RU,
TJ, TM), European (AL, AT, BE, BG, CH, CY, CZ, DE,
DK, EE, ES, FI, FR, GB, GR, HR, HU, IE, IS, IT, LT,
LU, LV, MC, MK, MT, NL, NO, PL, PT, RO, RS, SE,

SI, SK, SM, TR), OAPI (BF, BJ, CF, CG, CI, CM, GA,
GN, GQ, GW, KM, ML, MR, NE, SN, TD, TG).

Published:

— *with international search report (Art. 21(3))*

MODULAR GAS MONITORING SYSTEM

CROSS-REFERENCE TO RELATED APPLICATIONS

[0001] This application claims the benefit of U.S. Provisional Application No. 62/104,194, filed on January 16, 2015 and entitled “Modular Gas Monitoring System,” the contents of which are incorporated by reference in their entirety as if fully set forth herein.

BACKGROUND

[0002] Gas monitoring devices are used in industrial work environments where individuals may be at risk of exposure to a number of hazardous substances and environmental conditions, such as toxic gases, highly combustible gases, and oxygen-depleted environments. Typical gas monitoring devices often include one or more gas sensors, a processing component and firmware to analyze the gas sensor information, a display to present gas detection information to a user, and alarms to alert the user to any hazardous conditions and/or device status. In addition, the gas monitoring devices may include bump testing and calibration functionality to ensure they are calibrated and performing properly.

[0003] Gas monitoring devices are life-critical equipment in many industrial environments. Accordingly, manufacturers are continually developing improved components and firmware that are, for example, more efficient, more accurate, more sensitive, or longer lasting. However, it is often difficult and/or cost-prohibitive to update gas monitoring devices in the field. In addition, typical gas monitoring devices do not allow for individual electronic components to be updated. As a result, industrial users often do not obtain updated systems until they purchase a new gas monitoring device, which may take many years to occur. Accordingly, industrial users and workers would benefit from a system that allows for system-critical components of a gas monitoring device to be replaced and/or updated efficiently and cost-effectively without requiring the replacement of the entire gas monitoring device or the purchase of multiple pieces of equipment.

SUMMARY

[0004] This disclosure is not limited to the particular systems, devices and methods described, as these may vary. The terminology used in the description is for the purpose of describing the particular versions or embodiments only, and is not intended to limit the scope.

[0005] As used in this document, the singular forms “a,” “an,” and “the” include plural references unless the context clearly dictates otherwise. Unless defined otherwise, all technical and scientific terms used herein have the same meanings as commonly understood

by one of ordinary skill in the art. Nothing in this disclosure is to be construed as an admission that the embodiments described in this disclosure are not entitled to antedate such disclosure by virtue of prior invention. As used in this document, the term “comprising” means “including, but not limited to.”

[0006] In an embodiment, a gas monitoring system may include a module having a mobile form factor. The module may include a memory configured to store a firmware application and data, a processor operably coupled to the memory and configured to execute firmware to control the gas monitoring system, and at least one sensor. The gas monitoring system may include a base having at least one power source and at least one base interface. In one aspect, the gas monitoring system may include at least one module interface arranged within the base and configured to interface with the at least one base interface, thereby operably coupling the module to the base. The module may be configured to receive power from the base and to control the base responsive to being connected to the base.

[0007] In an embodiment, a method of monitoring gas using a gas monitoring apparatus may include detecting at least one concentration of at least one gas using the gas monitoring apparatus. The gas monitoring apparatus may include a module having a mobile form factor. The module may include a memory configured to store a firmware application and data, a processor operably coupled to the memory and configured to execute firmware to control the gas monitoring apparatus, and at least one sensor. The gas monitoring apparatus may include a base having at least one power source and at least one base interface. In one aspect, the gas monitoring apparatus may include at least one module interface arranged within the base and configured to interface with the at least one base interface, thereby operably coupling the module to the base. The module may be configured to receive power from the base and to control the base responsive to being connected to the base. In one aspect, the method may include generating at least one alarm configured to alert a user to a hazardous condition based on the at least one concentration of the at least one gas.

BRIEF DESCRIPTION OF THE DRAWINGS

[0008] The above and other objects of the present invention will become more readily apparent from the following detailed description taken in connection with the accompanying drawings.

[0009] FIG. 1 depicts an illustrative gas monitoring system according to some embodiments.

[0010] FIG. 2 depicts an illustrative gas sensor configuration of a gas monitoring system according to some embodiments.

[0011] FIG. 3 depicts illustrative inputs and outputs for a gas monitoring system according to some embodiments.

[0012] FIG. 4A depicts a front view of an illustrative gas monitoring system according to a first embodiment.

[0013] FIG. 4B depicts a back view of an illustrative gas monitoring system according to a first embodiment.

[0014] FIG. 4C depicts a front view of an illustrative gas monitoring system according to a second embodiment.

[0015] FIG. 4D depicts a back view of an illustrative gas monitoring system according to a second embodiment.

[0016] FIG. 5 illustrates various embodiments of a computing device for implementing the various methods and processes described herein.

DETAILED DESCRIPTION

[0017] The described technology generally relates to a gas monitoring system (the “system”) that includes a base component (the “base”) and a separate module component (the “module”). The module may be configured to be operably coupled to the base component through corresponding interface connectors. In some embodiments, the module may also be configured to be operably coupled to a docking station and/or a data transfer device through corresponding interface connectors to connect the module to the docking station and/or the data transfer device. In some embodiments, the module may be connected to the docking station and/or the data transfer device through a cradle. In some embodiments, the module may also be coupled wirelessly and/or through wired connections to other modules, to other system elements, and/or to external elements.

[0018] In some embodiments, the system may be fully functional, for example, to monitor for gases and generate alarms relating thereto, when the module is connected to the base. In some embodiments, the base may have limited or no functionality when disconnected from the module. For example, the base may be configured to provide display and alarm testing functions when disconnected from the module. In some embodiments, the module may have limited functionality when disconnected from the base. For instance, the module may be configured to provide gas detection, bump and calibration functions, and to communicate with a docking station and/or computing devices when disconnected from the

base. In some embodiments, the base may perform all or some of the functions described herein (for instance, have “full functionality”) when disconnected from the module. In some embodiments, the module may perform all or some of the functions described herein (for instance, have full functionality) when disconnected from the base.

[0019] In some embodiments, the module may be configured to include components that typically have an increased potential for upgrades, replacement, maintenance, or other modifications (“high maintenance components”) compared with components within the base. For example, high maintenance components may include gas sensors and firmware. Alarms, displays, or the like may typically have a lower rate of being upgraded, replaced, or requiring maintenance (“low maintenance components”) than other system components, for example, in comparison to high maintenance components. In some embodiments, the low maintenance components may be arranged within the base. The module may be configured as a smaller and more portable component as compared to the base, which may generally be larger and heavier than the module. In some embodiments, the module may have a mobile or ultra-mobile form factor that is configured to facilitate portability, for example, by being able to be easily carried by a user. In some embodiments, the base may have a stationary or substantially stationary form factor. For example, the base may be and/or may be installed within a stationary or substantially stationary object or structure, such as a wall, a vehicle, mining equipment, or the like. In this manner, high maintenance components may be arranged in a module that has a smaller and more portable form factor than the base or the system overall. For example, if new or updated components of the module are available, the module may be disconnected from the base in the field, transported to a location where the module may be updated, and then transported back to the field and connected to the base. In another example, if new or updated components of the module are available, the module may be disconnected from the base and the entire module replaced with a new module having the new or updated components. As such, industrial users may obtain an upgraded system without having to replace the entire system or transport the entire system to a different location. In addition, gas detection and processing functions, which are typically performed by high maintenance components, in the module may be separated from comparatively lower-level functions, which are typically low maintenance components, such as display and alarm functions, in the base.

[0020] In some embodiments, the base may be configured to operate with different types of modules, for example, having different gas sensors, firmware, or the like. In this

manner, a single base station may be used to provide different systems and/or functions depending on the type of module connected to the base station.

[0021] Accordingly, systems configured according to some embodiments may allow industrial users and system manufacturers to easily, efficiently, and cost-effectively upgrade their systems and use a wider range of gas detection and processing functions with a single base in the field than is available using conventional gas detection technology.

[0022] FIG. 1 depicts a gas monitoring system according to some embodiments. As shown in FIG. 1, a system **105** may include a module **110** and a base **115**. The module **110** may include various components, such as a battery **120a**, data logs **120b** (for example, data for bump tests, calibrations, measurement data, datalog data, diagnostics, errors, alarm events, instrument settings, sensor settings, or the like), communication transceivers **120c** (for example, wireless communication transceivers), gas sensors **120d**, a pump **120e** (for example, a sampling pump for aspirated operation), firmware **120f**, and/or a module interface connector **150**. The module **110** may also include a non-transitory memory and processing hardware for executing the firmware **120f**, generating and storing the data logs **120c**, controlling the functions of the system **105**, and/or executing a bootloader application. Illustrative memory elements and processing hardware may include, without limitation, a CPU **505**, ROM **510**, RAM **515**, and/or a memory device **525** (for instance, flash memory) depicted in FIG. 5. In some embodiments, the firmware **120f** may be upgraded via the bootloader application over a communication protocol, such as Modbus or through wireless communications. In some embodiments, certain of the components of the gas detection system may be for internal use only or customer (or user) facing components, as indicated according to legend **190**.

[0023] In some embodiments, the system **105** may be configured to operate in different modes depending on the type of module **110** that is installed in the base **115**. Non-limiting types of modes may include a diffusion mode and an aspirated mode.

[0024] In some embodiments, the system **105** may be configured to communicate with other systems, for instance, through the communication transceivers **120c**. The system **105** may be able to transmit and/or receive information to/from other systems including, without limitation, alert messages (for instance, alarms, gas concentrations, faults, low battery conditions, device and/or component identification, or the like) and/or ongoing status messages (for instance, “on,” “working,” identifiers, or the like).

[0025] The base **115** may include various components, such as a display **125a**, alarms **125b**, a human machine interface (HMI) **125c**, warnings **125d**, battery charge indicator **125e**, a battery **125f**, and a base interface connector **125g**. The module interface connector **150** may be connected to the base interface connector **125g** to operably couple the module **110** to the base **115**. Non-limiting examples of alarms **125b** may include, without limitation, audio and/or visual local high gas alarm, local low gas alarm, local positive over-range alarm, local negative over-range alarm, and/or a remote gas alarm. The warnings **125d** may be configured to get the attention of users in the area of the system **105**, such as through flashing lights or warning tones that are different than alarm tones. Non-limiting examples of warnings may include audio and/or visual low battery warning, calibration due warning, bump due warning, bump fail warning, zero fail warning, local system error warning, RAM test failure warning, flash test failure warning, sensor checksum failure warning, pump test warning, and/or instrument checksum failure warning.

[0026] In some embodiments, the module **110** may be electrically and physically connected to the base **115**. In some embodiments, the module **110** and the base **115** may be configured to communicate through the interface connectors **150** and **125g**. The interface connectors **150** and **125g** may be configured to communicate using any communication protocol known in the art. In some embodiments, the module interface connectors **150** and **125g** may be configured to communicate using a serial communications protocol, such as the Modbus communication protocol. In some embodiments, the base **115** may include an indicator (not shown) configured to indicate whether the module **110** is and/or is not connected (or properly connected) to the base **115**. In some embodiments, the system **105** may only function, or may only function to monitor gases, when the module **110** is connected to the base **115**. In some embodiments, the module **110** and/or the base **115** may be configured to interface with additional devices, for example, through the interface connectors **150** and **125g**. In some embodiments, the additional devices may include a maintenance device, such as a calibration adapter.

[0027] In some embodiments, neither the module **110** nor the base **115** is capable of operating independently. For instance, in some embodiments, the module **110** may only operate when installed in the base **115** or the cradle **130** (i.e., for docking functions), and the base may only operate when the module is connected thereto. In such embodiments, only a complete system **105** (for instance, a system having a base **115** with a module **110** connected thereto) is capable of performing gas detection and alarm functions.

[0028] In some embodiments, the module **110** may be operably coupled to a docking station **140**. In some embodiments, the module **110** may be operably coupled to the docking station **140** through a cradle **130**, for instance, by connecting the module interface connector **150** to interface connector **135** of the cradle. The cradle **130** may be operably coupled to the docking station **140**. In some embodiments, the docking station **140** may be configured to provide docking station functions to the module **110**. In an embodiment using a cradle **130**, the docking station **140** may be configured to provide the docking station functions to the module **110** through the cradle. Illustrative and non-limiting examples of docking station functions may include bump and calibration testing, reporting, information presentation via computing devices **150d**, **150e** in communication with the docking station, and other docking station functions as would be known to a person having ordinary skill in the art.

[0029] In some embodiments, the docking station **140** may be configured as an iNet™-compatible docking station as provided by Industrial Scientific Corporation of Pittsburgh, Pennsylvania, United States. In some embodiments, the docking station **140** may be configured as a DS2 Docking Station™ provided by Industrial Scientific Corporation. The docking station **140** may be in communication with various networks, such as the Internet **170a** and/or an Ethernet network **170b**. Through the networks **170a**, **170b**, the docking station **140** may be in communication with various management systems and/or software, including, without limitation, DSX™ Docking Station servers **150c** and software **155c** and iNet™ administrative consoles **165a**, databases **165b**, servers **165c**, and control systems **165d**.

[0030] The module **110** may be in communication with various computing devices **150a**, **150b**, for example, through communication transceiver **120e**. The module **110** may communicate with the computing devices **150a**, **150b** using various communication protocols and/or software as would be known to a person having ordinary skill in the art. In some embodiments, the module **110** may communicate with the computing devices **150a**, **150b** using Device Upgrading Service Software (DUSS) and/or Accessory Software (AccSW) as provided by Industrial Scientific Corporation for, among other things, upgrading the firmware **120f** of the module. Calibration and/or bump testing of the module **110** may be performed using various calibration and/or bump testing devices **145**, for example, in addition to any calibration and/or bump testing functionality provided through the docking station **140**.

[0031] The system **105** may use various power sources to power the system and/or charge the batteries **120a**, **125f** of the components, such as a charging cable **180a** (for example, DC to DC, 12V, or the like), inlet power **180b** (for example, DC to DC, 12V, or the like), and/or inlet power **180c** (for example, AC to DC, 100-240V, or the like) through various charging accessories **175** and/or field deployable, intrinsically safe power supplies **185**. In some embodiments, at least one of the power sources may be arranged within the base **115**. In some embodiments, at least one of the power sources may be arranged within the module **110**. In some embodiments, the module **110** may be configured to receive power from the base **115**. In some embodiments, the module **110** may not include a power source and may receive power to operate from power sources arranged within the base **115**.

[0032] The gas sensors **120d** may include any gas sensors known in the art. Non-limiting examples of sensors **120d** may include catalytic sensors, electrochemical sensors, infrared (IR) sensors, and photo-ionization detection (PID) sensors.

[0033] In some embodiments, the module **110** may include one gas sensor **120d**. In some embodiments, the module **110** may include a plurality of gas sensors **120d**. In some embodiments, the module **110** may include 1 gas sensor **120d**, 2 gas sensors, 3 gas sensors, 4 gas sensors, 5 gas sensors, 10 gas sensors, 15 gas sensors, 20 gas sensors, 50 gas sensors, 100 gas sensors, 1000 gas sensors, 1-3 gas sensors, 1-5 gas sensors, 1-10 gas sensors, 1-100 gas sensors, 1-1000 gas sensors, and any value or range between any two of these values (including endpoints). Although non-limiting examples of the number of gas sensors **120d** are provided herein, embodiments are not so limited, as the module **110** may include any number of gas sensors capable of operating according to some embodiments.

[0034] In some embodiments, the module **110** may not include a gas sensor **120e**. In some embodiments, the module **110** may be configured to operate as a wireless receiving station with or without gas sensors **120d**. In some embodiments, the module **110** (and/or one or more other portions of the system **105**) may include non-gas sensors (not shown). Illustrative and non-restrictive examples of non-gas sensors may include radiation sensors, weather sensors, accelerometers, light sensors, motion sensors, video sensors, tactile sensors, or any other type of sensor known in the art.

[0035] In some embodiments including a plurality of gas sensors **120d**, portions of the gas sensors may be configured to detect and/or measure different types of gas. Non-limiting types of gas that may be detected by the gas sensors **120d** may include oxygen, lower explosive limit (LEL) of flammable gases and vapors, carbon monoxide, hydrogen

sulfide, carbon monoxide and hydrogen sulfide (COSH), ammonia, nitrogen dioxide, sulfur dioxide, volatile organic compounds (VOC), carbon dioxide, carbon monoxide with low hydrogen, chlorine, hydrogen, hydrogen cyanide, combustible gases, methane, hydrogen chloride, nitric oxide, phosphine, and combinations thereof. The gas sensors **120d** may be arranged in various configurations on and within the module **110**. For instance, a plurality of gas sensors **120d** may be arranged on multiple surfaces and/or planes of the module **110**. In some embodiments, at least a portion of the gas sensors **120d** may include redundant sensors, for example, such as sensors using DualSense™ sensor technology provided by Industrial Scientific Corporation.

[0036] FIG. 2 depicts an illustrative gas sensor configuration for a module having 6 sensor positions according to some embodiments. As shown in FIG. 2, a plurality of sensors **205** associated with sensor numbers **210** may be arranged on or within a module. The sensor configuration of a module may include low power sensor configurations **220** and/or high and low power sensor configurations **230**. Readings **240** for the sensors may be presented on a display **225** on the base. The legend **215** provides the shading and/or outline properties to indicate various types of sensors **205**. Non-limiting examples of sensors may include high power sensors (for instance, catalytic bead sensors, infrared sensors, or photoionization detectors) **A**, low power sensors (for instance, electrochemical sensors or low power infrared sensors) **B/D**, dual gas sensors (for instance, carbon monoxide/hydrogen sulfide sensors) **C**, redundant sensors **E** (for instance, DualSense™ sensors), and non-redundant (or “single”) sensors **F**.

[0037] FIG. 3 depicts illustrative inputs and outputs for a gas monitoring system according to some embodiments. As shown in FIG. 3, a system **305** may receive various inputs **310a-g** and provide various outputs **315a-f**. Illustrative inputs may include, without limitation, power source inputs **310a** (including, for instance, temporary and continuous power source inputs), sample and/or hazardous gas input **310b** that may be analyzed by the system **305**, bump and/or calibration gas input **310c** to test and/or calibrate the system, user input **310d** for controlling the system or accessing system information (for instance, unit on/off, screen selection, configuration, or the like), inter-unit communication **310e** between different systems (for instance, alarm or status messages), configuration settings **310f**, and device and/or application communication input **310g**, for example, for communicating to external computing devices and/or applications.

[0038] Non-limiting examples of outputs generated by the system **305** may include alarms **315a** (for example, audio, visual, confidence signals, low battery, system error, or the like), user information **315b** (for example, sensor types, system status, sensor replacement, battery state, calibration needed, last calibration date, and/or exposure data), software communication **315c** (for example, communication to software for configuration, maintenance and service, reporting, or the like, such as iNet™, DUSS, AccSW, and/or manufacturer applications), device communication **315d** (For example, alarm relay messages), communication **315e** to other systems, and outgoing device and/or application communications **315f** (for example, device logs, status, alarms, or the like). The alarms **315a** may be configured as audio and/or visual alarms for communicating the current status of the system **305** to the immediately surrounding area, other systems, and/or external computing devices or applications.

[0039] FIG. 4A depicts an image of a front view of an illustrative gas monitoring system according to a first embodiment and FIG. 4C depicts a graphical representation of a front view of an illustrative gas monitoring system according to a second embodiment. As shown in FIGS. 4A and 4C, a system **400** may include a base **405** and modules **410a**, **410b**. In some embodiments, the system **400** may use a plurality of modules **410a**, **410b**. In some embodiments, the system **400** may use one module **410a**, **410b**. FIGS. 4A and 4C depict a diffusion module **410a** and an aspirated module **410b**. The base includes a display **415** and buttons **420** configured to initiate certain system functions. Non-limiting examples of buttons **420** may include a power on/off button and a user interface access button. FIG. 4B depicts an image of a back view of an illustrative gas monitoring system according to a first embodiment and FIG. 4D depicts a graphical representation of a back view of an illustrative gas monitoring system according to a second embodiment. As shown in FIGS. 4B and 4D, in some embodiments, a module **410a** or **410b**, respectively, may be installed in the base **405** to form a complete system **400**. As shown in FIGS. 4A-4D, the gas monitoring system and/or components thereof may have a shape generally resembling a safety cone. For instance, the base **405** may have a shape generally resembling a safety cone.

[0040] FIG. 5 depicts a block diagram of exemplary internal hardware that may be used to contain or implement the various computer processes and systems as discussed above, for example, as a processing circuit for module **110**. A bus **500** serves as the main information highway interconnecting the other illustrated components of the hardware. CPU **505** is the central processing unit of the system, performing calculations and logic operations

required to execute a program. CPU **505**, alone or in conjunction with one or more of the other elements disclosed in FIG. 5, is an exemplary processing device, computing device or processor as such terms are used within this disclosure. Read only memory (ROM) **510** and random access memory (RAM) **515** constitute exemplary memory devices.

[0041] A controller **520** interfaces with one or more optional memory devices **525** to the system bus **500**. These memory devices **525** may include, for example, an external or internal DVD drive, a CD ROM drive, a hard drive, flash memory, a USB drive and/or the like. As indicated previously, these various drives and controllers are optional devices. Additionally, the memory devices **525** may be configured to include individual files for storing any software modules or instructions, auxiliary data, common files for storing groups of results or auxiliary, or one or more databases for storing the result information, auxiliary data, and related information as discussed above.

[0042] Program instructions, software or interactive modules for performing any of the functional steps as described above may be stored in the ROM **510** and/or the RAM **515**. Optionally, the program instructions may be stored on a tangible computer-readable medium such as a compact disk, a digital disk, flash memory, a memory card, a USB drive, an optical disc storage medium, such as a Blu-ray™ disc, and/or other recording medium.

[0043] An optional display interface **530** may permit information from the bus **500** to be displayed on the display **535** in audio, visual, graphic or alphanumeric format. Communication with external devices may occur using various communication ports **570**. An exemplary communication port **570** may be attached to a communications network, such as the Internet or a local area network.

[0044] The hardware may also include an interface **575** which allows for receipt of data from input devices such as a keyboard **550** or other input device **555** such as a mouse, a joystick, a touch screen, a remote control, a pointing device, a video input device and/or an audio input device.

[0045] The present disclosure is not to be limited in terms of the particular embodiments described in this application, which are intended as illustrations of various aspects. Many modifications and variations can be made without departing from its spirit and scope, as will be apparent to those skilled in the art. Functionally equivalent methods and apparatuses within the scope of the disclosure, in addition to those enumerated herein, will be apparent to those skilled in the art from the foregoing descriptions. Such modifications and variations are intended to fall within the scope of the appended claims. The present

disclosure is to be limited only by the terms of the appended claims, along with the full scope of equivalents to which such claims are entitled. It is to be understood that this disclosure is not limited to particular methods, reagents, compounds, compositions or biological systems, which can, of course, vary. It is also to be understood that the terminology used herein is for the purpose of describing particular embodiments only, and is not intended to be limiting.

[0046] With respect to the use of substantially any plural and/or singular terms herein, those having skill in the art can translate from the plural to the singular and/or from the singular to the plural as is appropriate to the context and/or application. The various singular/plural permutations may be expressly set forth herein for sake of clarity.

[0047] It will be understood by those within the art that, in general, terms used herein, and especially in the appended claims (*e.g.*, bodies of the appended claims) are generally intended as “open” terms (*e.g.*, the term “including” should be interpreted as “including but not limited to,” the term “having” should be interpreted as “having at least,” the term “includes” should be interpreted as “includes but is not limited to,” etc.). While various compositions, methods, and devices are described in terms of “comprising” various components or steps (interpreted as meaning “including, but not limited to”), the compositions, methods, and devices can also “consist essentially of” or “consist of” the various components and steps, and such terminology should be interpreted as defining essentially closed-member groups. It will be further understood by those within the art that if a specific number of an introduced claim recitation is intended, such an intent will be explicitly recited in the claim, and in the absence of such recitation no such intent is present. For example, as an aid to understanding, the following appended claims may contain usage of the introductory phrases “at least one” and “one or more” to introduce claim recitations. However, the use of such phrases should not be construed to imply that the introduction of a claim recitation by the indefinite articles “a” or “an” limits any particular claim containing such introduced claim recitation to embodiments containing only one such recitation, even when the same claim includes the introductory phrases “one or more” or “at least one” and indefinite articles such as “a” or “an” (*e.g.*, “a” and/or “an” should be interpreted to mean “at least one” or “one or more”); the same holds true for the use of definite articles used to introduce claim recitations. In addition, even if a specific number of an introduced claim recitation is explicitly recited, those skilled in the art will recognize that such recitation should be interpreted to mean at least the recited number (*e.g.*, the bare recitation of “two recitations,” without other modifiers, means at least two recitations, or two or more

recitations). Furthermore, in those instances where a convention analogous to “at least one of A, B, and C, etc.” is used, in general such a construction is intended in the sense one having skill in the art would understand the convention (*e.g.*, “a system having at least one of A, B, and C” would include but not be limited to systems that have A alone, B alone, C alone, A and B together, A and C together, B and C together, and/or A, B, and C together, etc.). In those instances where a convention analogous to “at least one of A, B, or C, etc.” is used, in general such a construction is intended in the sense one having skill in the art would understand the convention (*e.g.*, “a system having at least one of A, B, or C” would include but not be limited to systems that have A alone, B alone, C alone, A and B together, A and C together, B and C together, and/or A, B, and C together, etc.). It will be further understood by those within the art that virtually any disjunctive word and/or phrase presenting two or more alternative terms, whether in the description, claims, or drawings, should be understood to contemplate the possibilities of including one of the terms, either of the terms, or both terms. For example, the phrase “A or B” will be understood to include the possibilities of “A” or “B” or “A and B.”

[0048] In addition, where features or aspects of the disclosure are described in terms of Markush groups, those skilled in the art will recognize that the disclosure is also thereby described in terms of any individual member or subgroup of members of the Markush group.

[0049] As will be understood by one skilled in the art, for any and all purposes, such as in terms of providing a written description, all ranges disclosed herein also encompass any and all possible subranges and combinations of subranges thereof. Any listed range can be easily recognized as sufficiently describing and enabling the same range being broken down into at least equal halves, thirds, quarters, fifths, tenths, etc. As a non-limiting example, each range discussed herein can be readily broken down into a lower third, middle third and upper third, etc. As will also be understood by one skilled in the art all language such as “up to,” “at least,” and the like include the number recited and refer to ranges which can be subsequently broken down into subranges as discussed above. Finally, as will be understood by one skilled in the art, a range includes each individual member. Thus, for example, a group having 1-3 cells refers to groups having 1, 2, or 3 cells. Similarly, a group having 1-5 cells refers to groups having 1, 2, 3, 4, or 5 cells, and so forth.

[0050] Various of the above-disclosed and other features and functions, or alternatives thereof, may be combined into many other different systems or applications. Various presently unforeseen or unanticipated alternatives, modifications, variations or

improvements therein may be subsequently made by those skilled in the art, each of which is also intended to be encompassed by the disclosed embodiments.

CLAIMS

What is claimed is:

1. A monitoring system comprising:
a module having a mobile form factor, the module comprising:
a memory configured to store a firmware application and data,
a processor operably coupled to the memory and configured to execute firmware to control the gas monitoring system, and
at least one sensor;
a base comprising at least one power source and at least one base interface; and
at least one module interface arranged within the module and configured to interface with the at least one base interface, thereby operably coupling the module to the base, wherein the module is configured to receive power from the base and to control the base responsive to being connected to the base.
2. The monitoring system of claim 1, wherein the gas monitoring system is operable to monitor data measured via the at least one sensor responsive to the module being operably coupled to the base.
3. The monitoring system of claim 1, wherein the at least one sensor comprises at least one of a gas sensor, a radiation sensor, a weather sensor, an ambient environment sensor, sound pressure wave sensor, and a motion sensor.
4. The monitoring system of claim 1, wherein the module further comprises a wireless communication transceiver.
5. The monitoring system of claim 4, wherein the wireless communication transceiver is configured to allow communications between the module and other modules external to the gas monitoring system.
6. The monitoring system of claim 4, wherein the module is configured to transmit and receive at least one of alert messages and status messages from other modules external to the gas monitoring system via the wireless communication transceiver.

7. The monitoring system of claim 1, wherein the gas monitoring system is configured to operate in one of a diffusion mode and an aspirated mode determined based on a type of the module.
8. The monitoring system of claim 1, wherein the module is configured to interface with at least one maintenance device when disconnected from the base, the at least one maintenance device comprising at least one of a docking station and a data transfer device.
9. The monitoring system of claim 1, wherein the at least one sensor comprises a gas sensor, and wherein the gas monitoring system is operable to monitor gas measured via the gas sensor responsive to the module being operably coupled to the base.
10. The monitoring system of claim 1, wherein the module is configured to interface with at least one of a bump device and a calibration device.
11. The monitoring system of claim 1, wherein the module is non-operational when disconnected from the base.
12. The monitoring system of claim 1, wherein the module is configured to perform gas detection functions, bump and calibration functions, and to communicate with a computing device when disconnected from the base.
13. The monitoring system of claim 1, wherein the base is non-operational when disconnected from the module.
14. The monitoring system of claim 1, wherein the base is configured to perform display functions and alarm functions when disconnected from the module.
15. A method of monitoring gas using a gas monitoring apparatus, the method comprising:
 - detecting at least one concentration of at least one gas using the gas monitoring apparatus, the gas monitoring apparatus comprising:
 - a module having a mobile form factor, the module comprising:

a memory configured to store a firmware application and data,
a processor operably coupled to the memory and configured to execute
firmware to control the gas monitoring apparatus, and
at least one gas sensor,
a base comprising at least one power source and at least one base interface,
and
at least one module interface arranged within the base and configured to
interface with the at least one base interface, thereby operably coupling the module to
the base, wherein the module is configured to receive power from the base and to
control the base responsive to being connected to the base; and
generating at least one alarm configured to alert a user to a hazardous condition based
on the at least one concentration of the at least one gas.

16. The method of claim 15, wherein the at least one sensor comprises a gas sensor, and
wherein the gas monitoring apparatus is operable to monitor gas measured via the gas sensor
responsive to the module being operably coupled to the base.

17. The method of claim 15, further comprising transmitting and receiving at least one of
an alert message and a status message from at least one second module external to the gas
monitoring apparatus via a wireless communication transceiver arranged within the module
of the gas monitoring apparatus.

18. The method of claim 15, wherein the gas monitoring apparatus is configured to
operate in one of a diffusion mode and an aspirated mode determined based on a type of the
module.

19. The method of claim 15, further comprising powering the module by connecting the
module to the base.

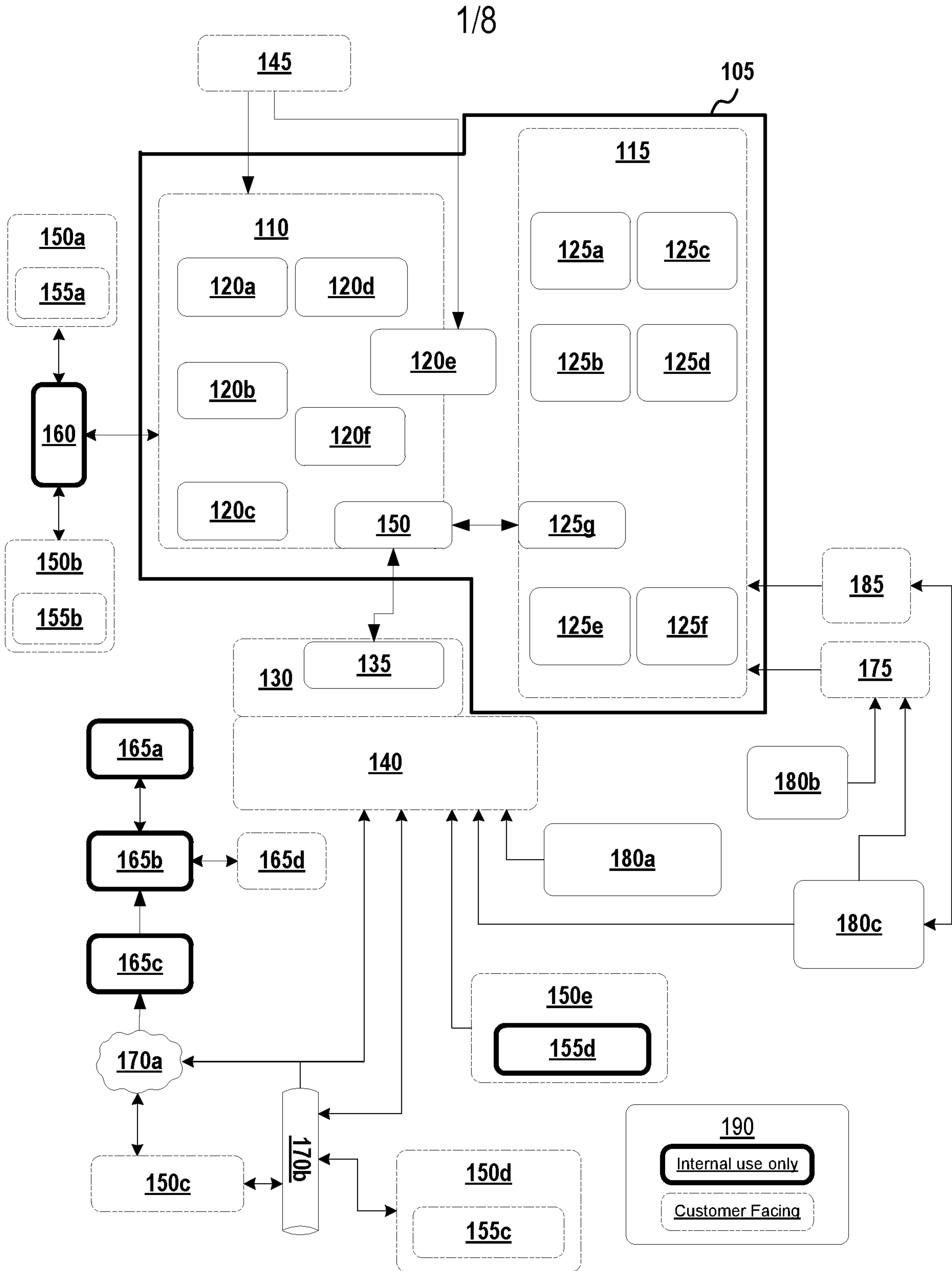

FIG. 1

2/8

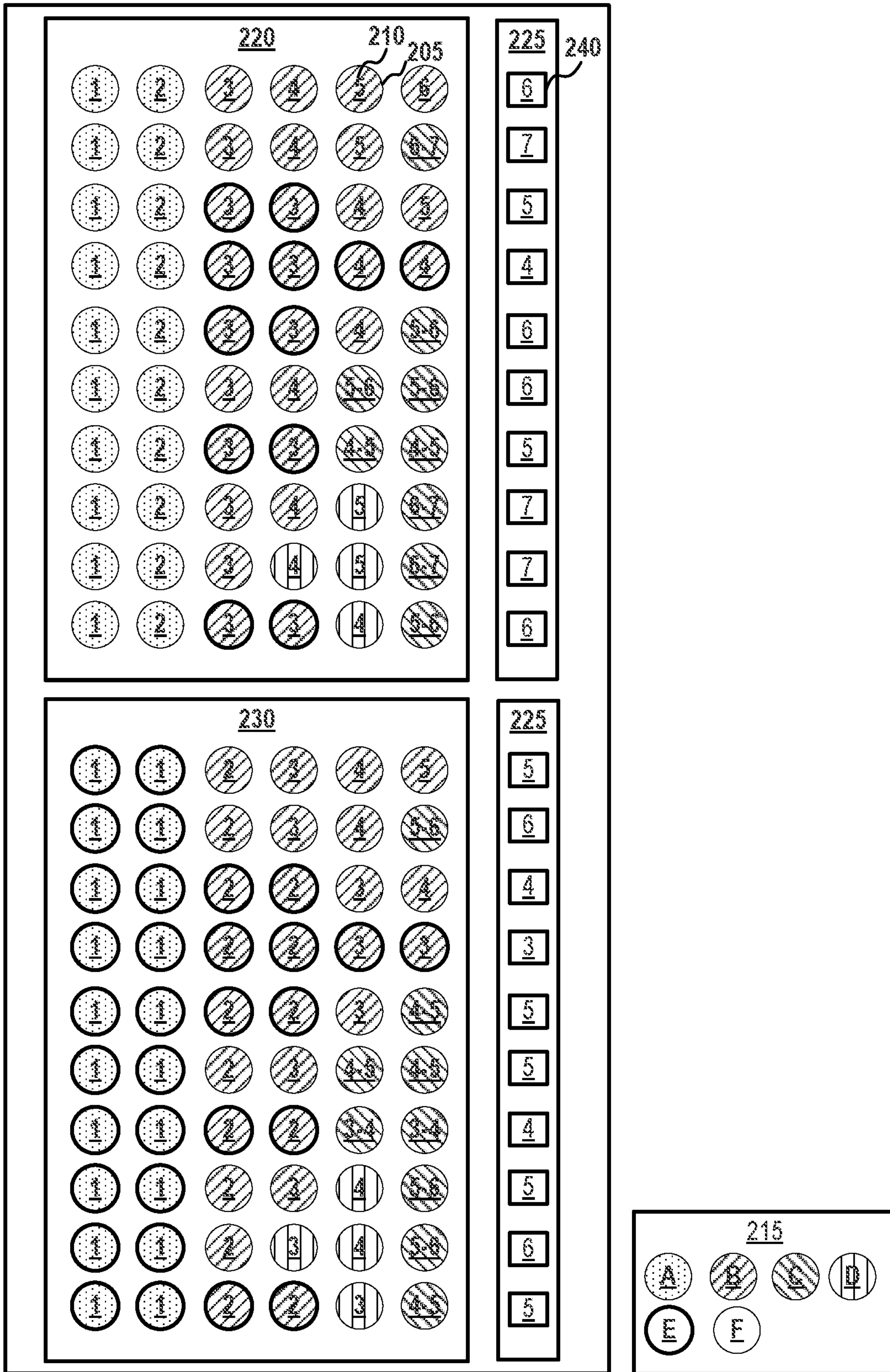

FIG. 2

3/8

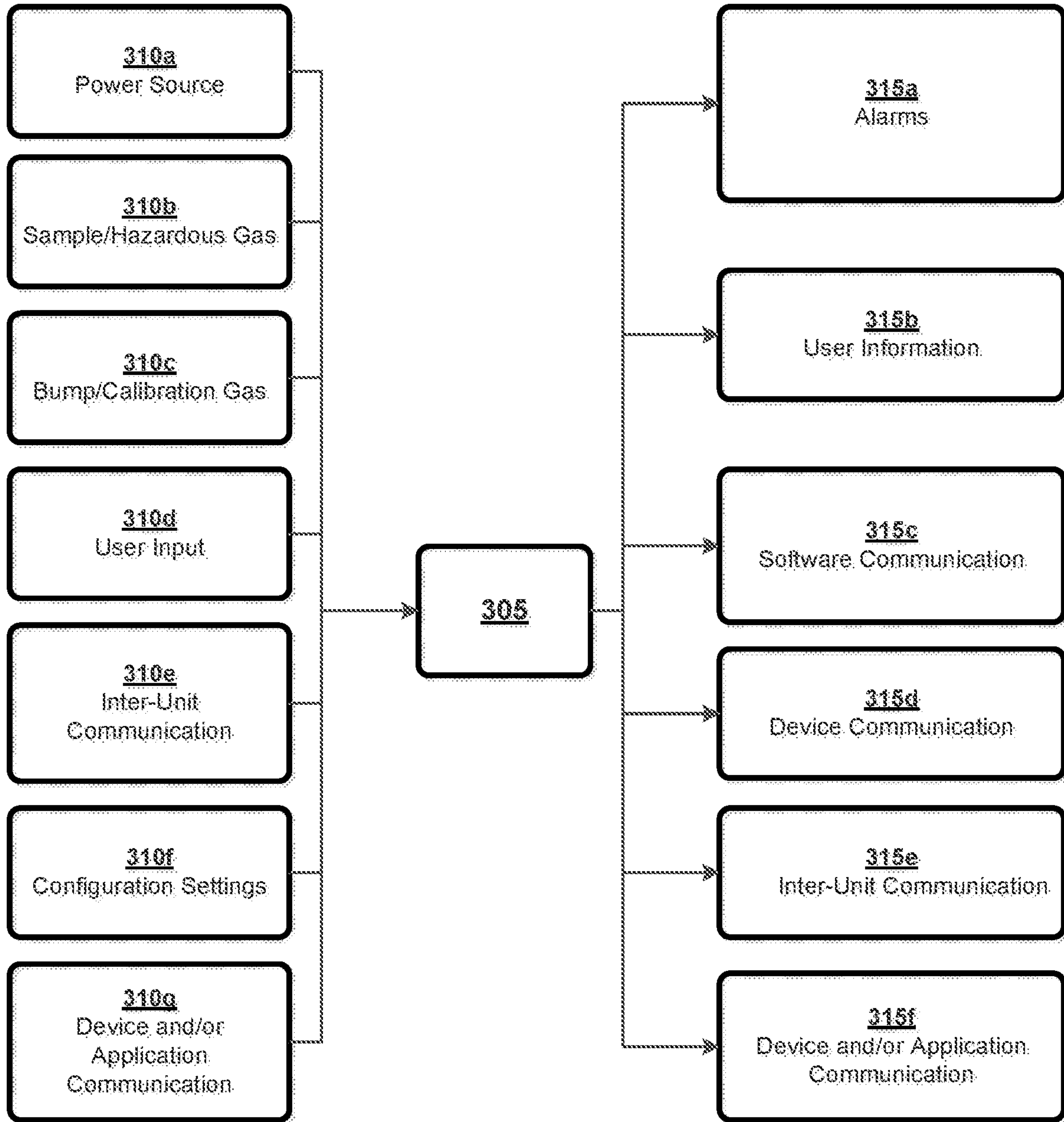

FIG. 3

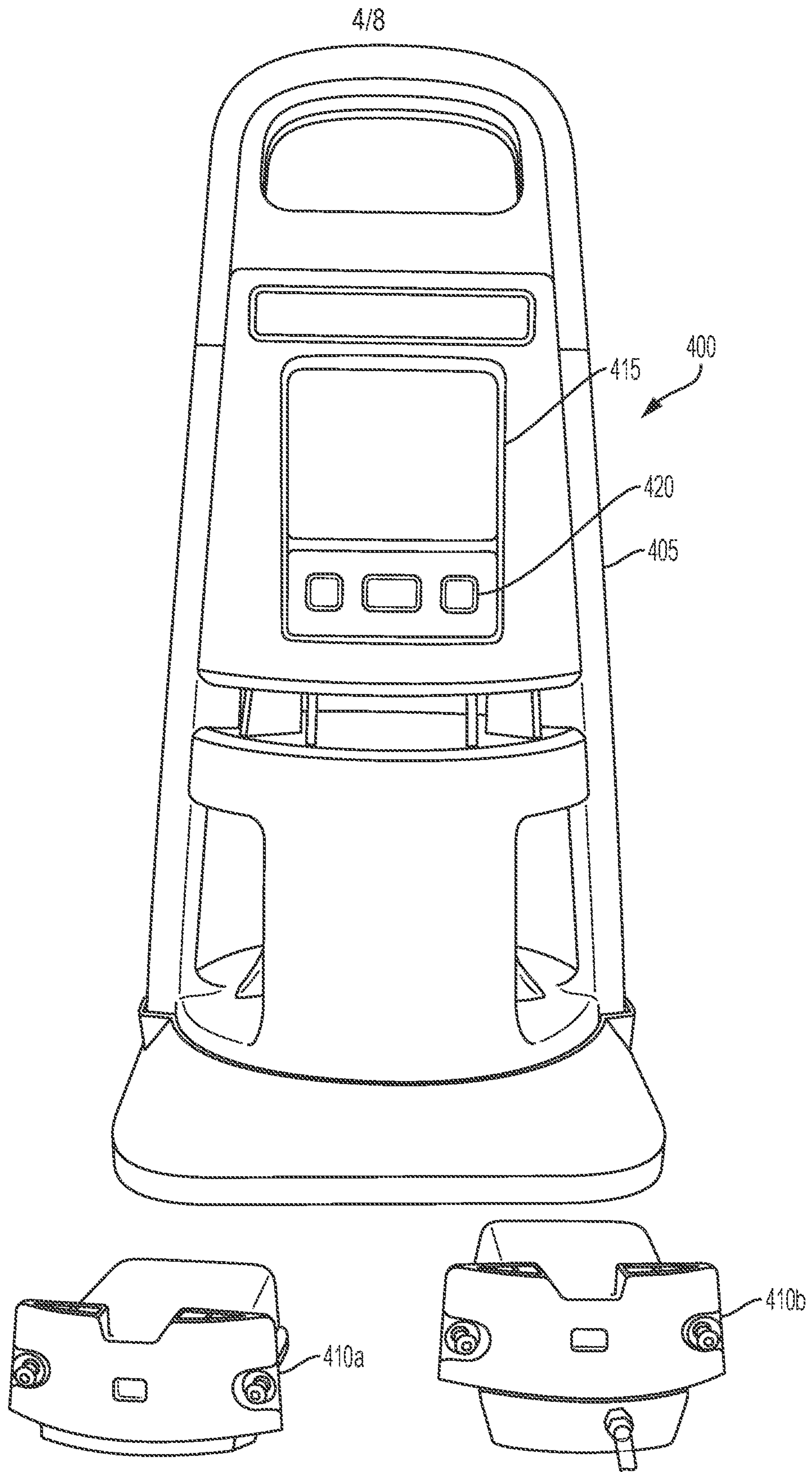

FIG. 4A

5/8

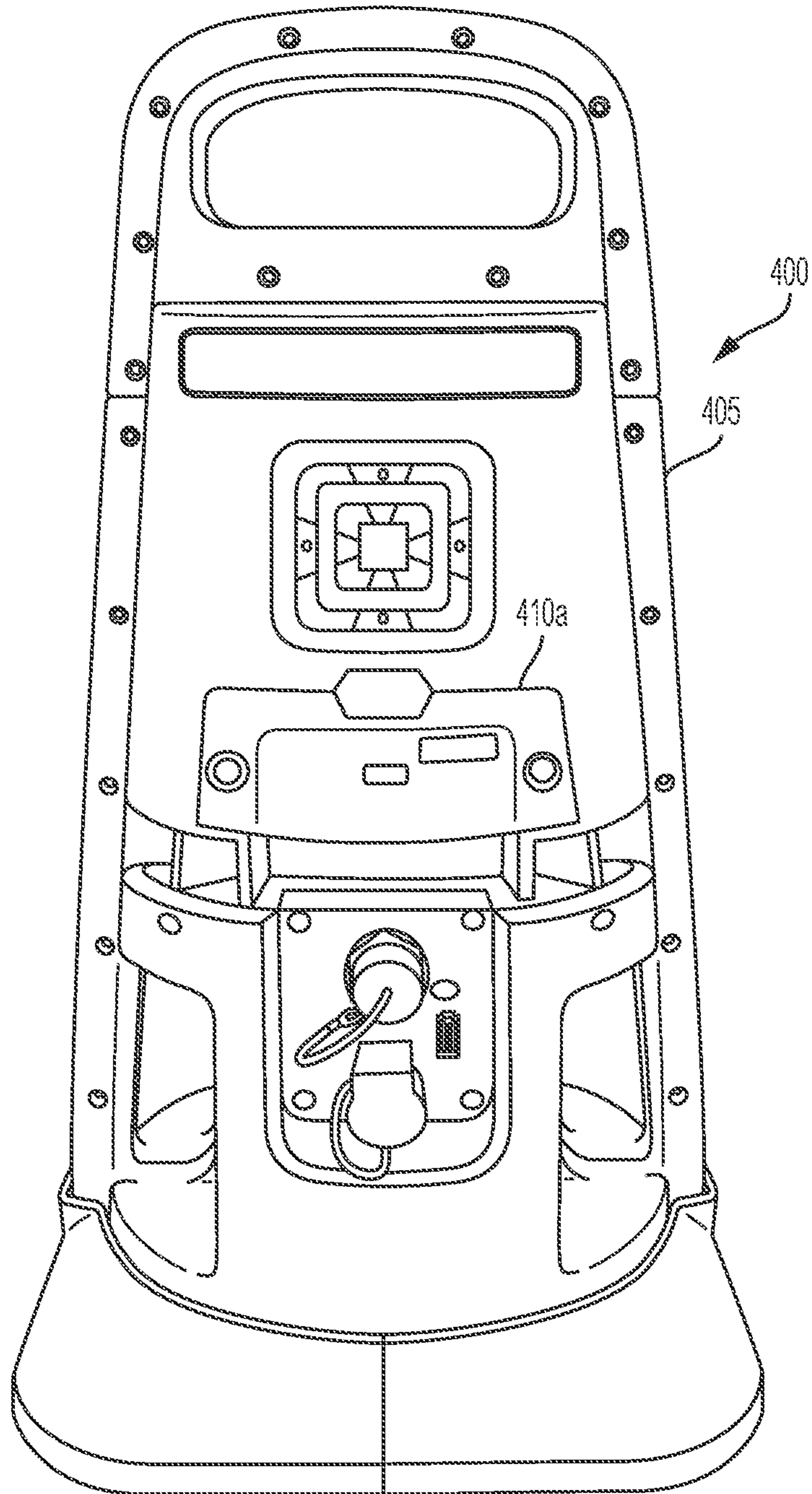
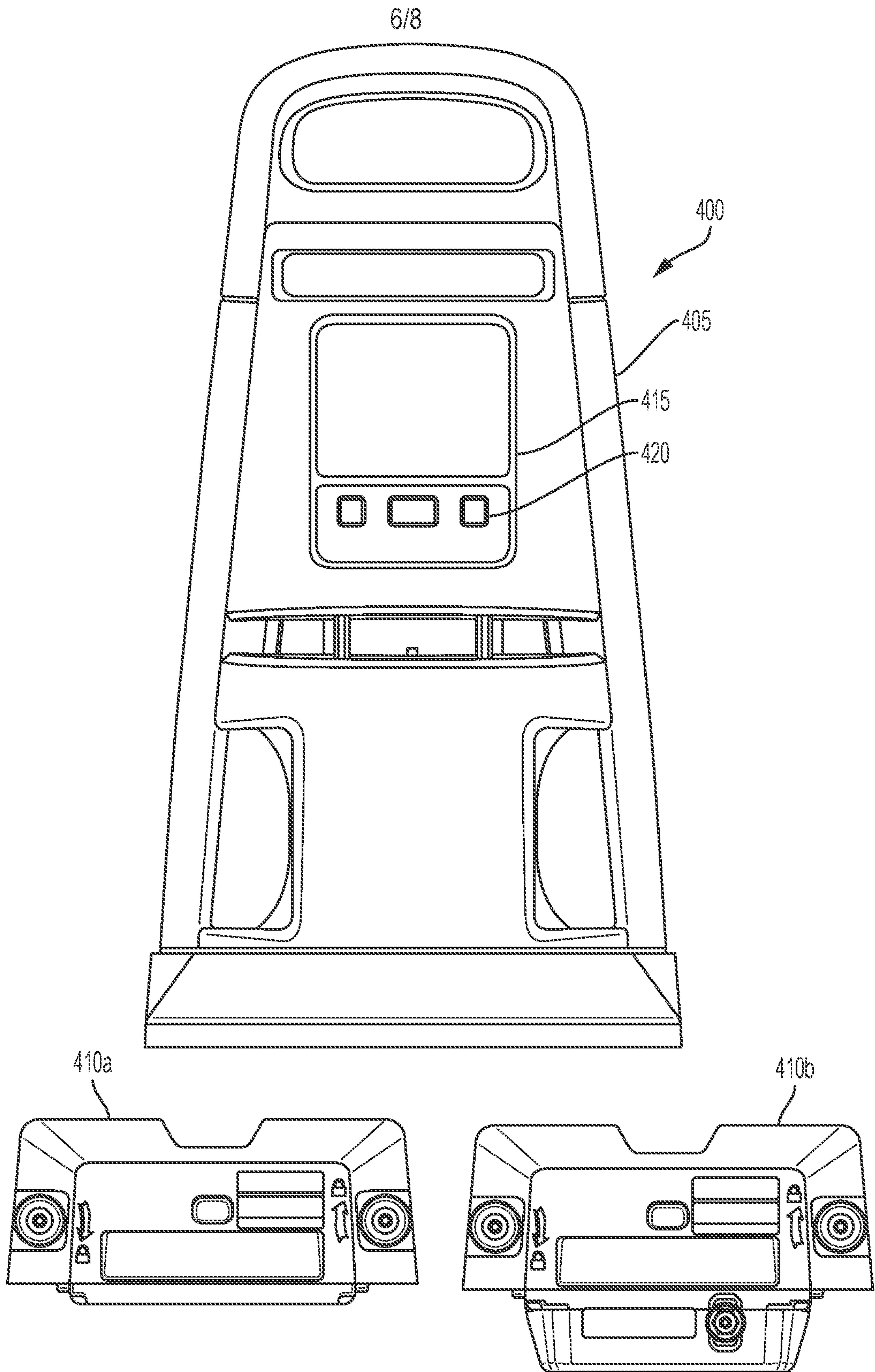

FIG. 4B



718

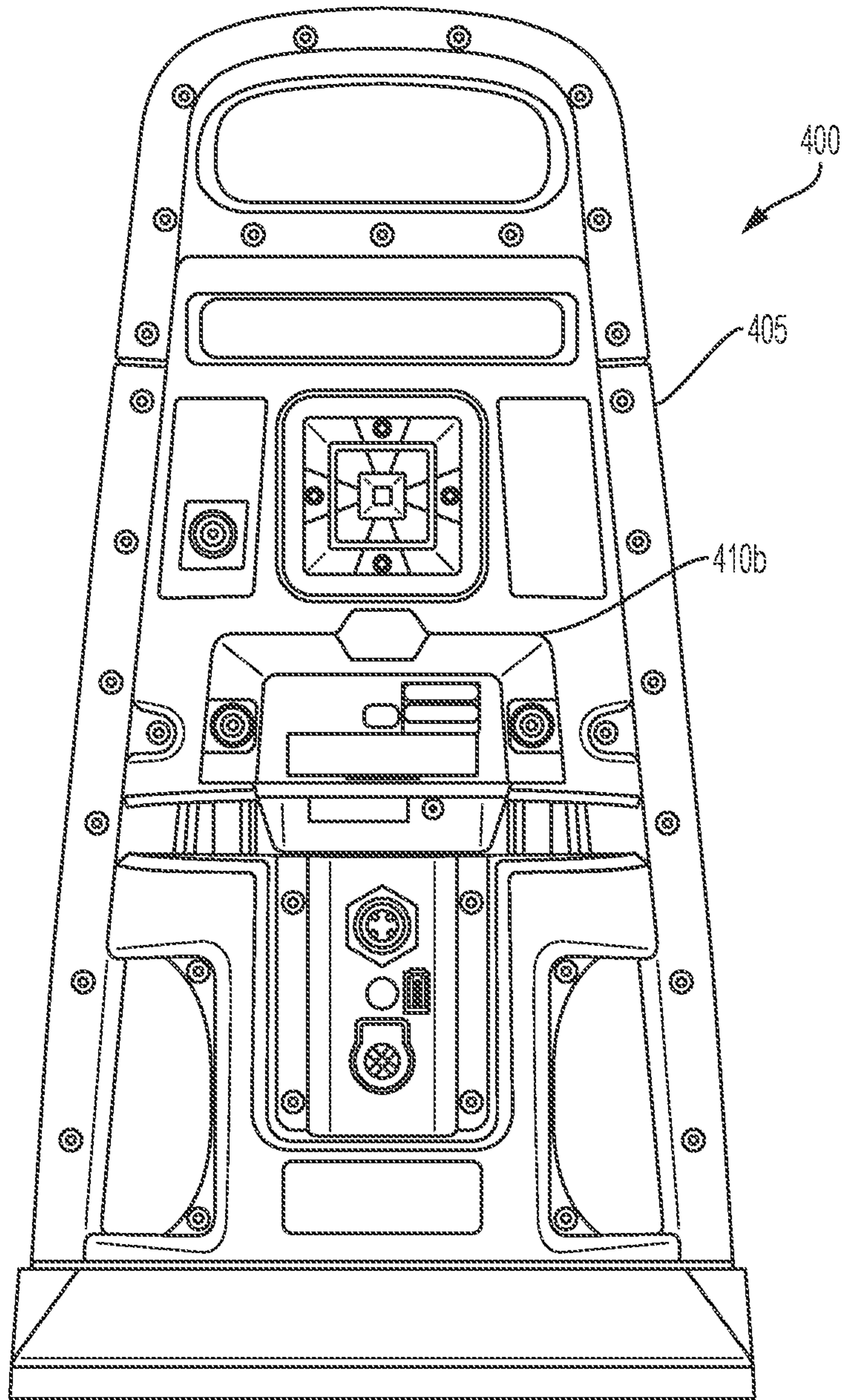

FIG. 4D

8/8

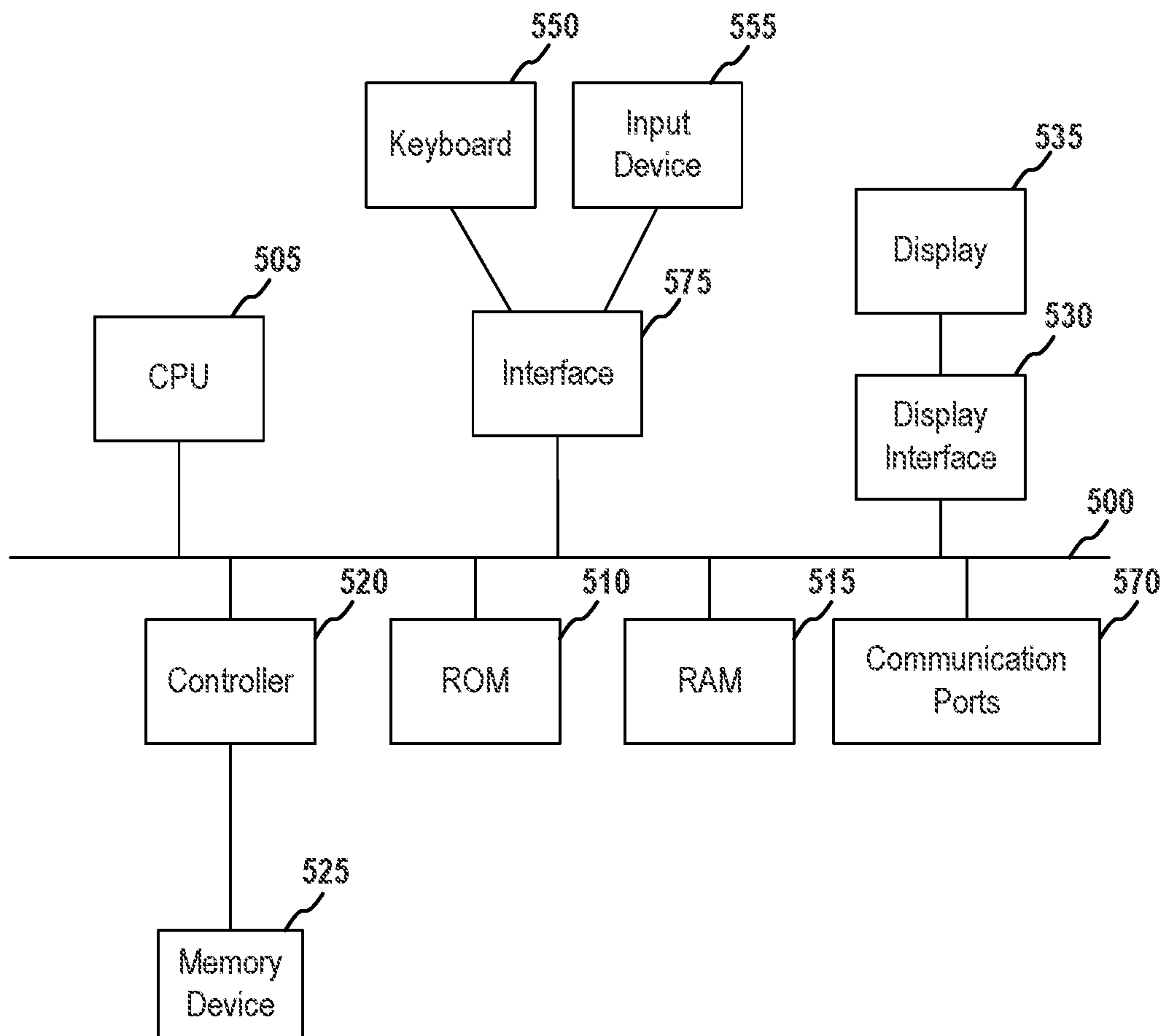

FIG. 5

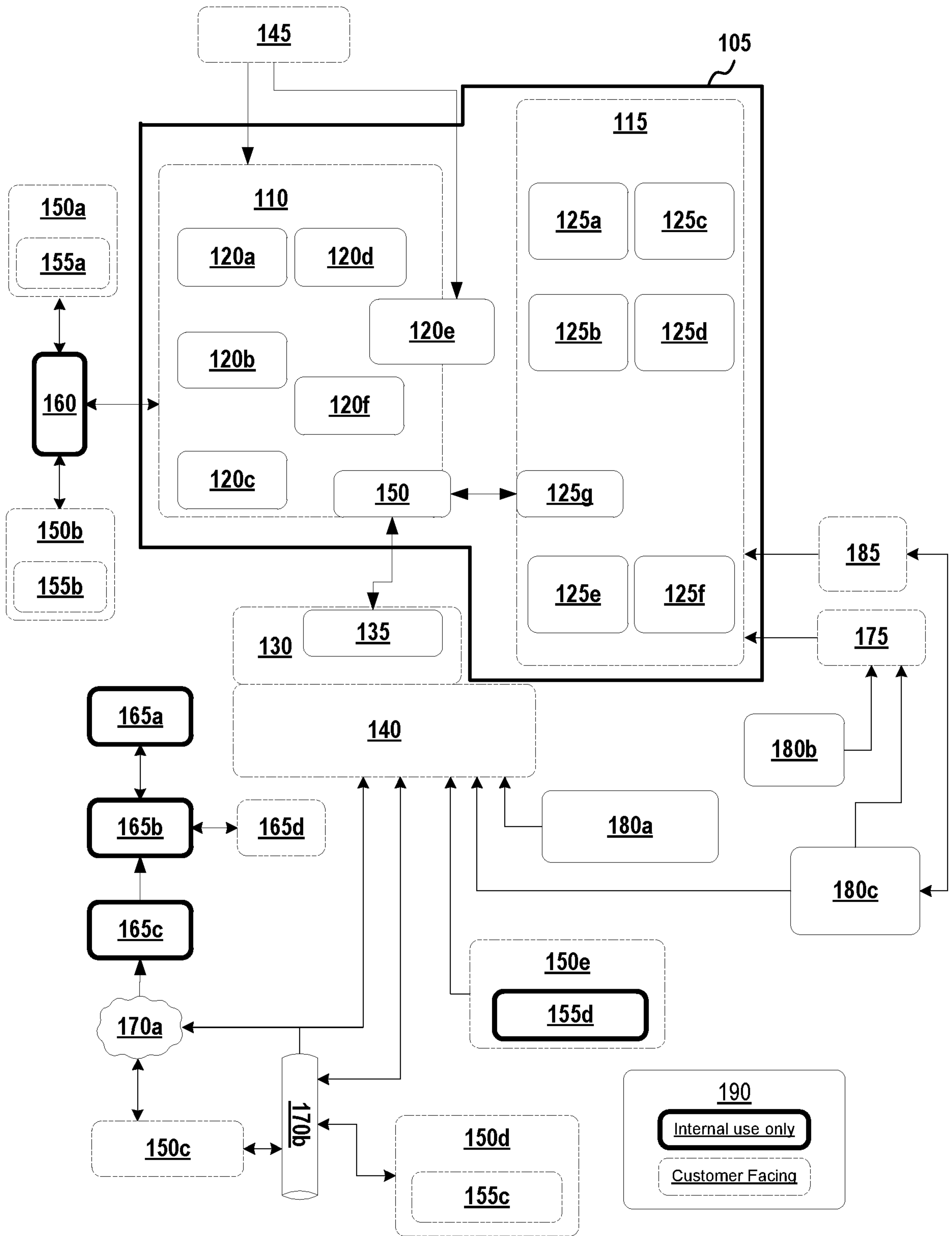

FIG. 1