



(12)

EUROPEAN PATENT APPLICATION

(43) Date of publication:
07.06.2006 Bulletin 2006/23

(51) Int Cl.:
B65D 5/48 (2006.01)

(21) Application number: 06004616.6

(22) Date of filing: 07.08.2001

(84) Designated Contracting States:
AT BE CH CY DE DK ES FI FR GB GR IE IT LI LU
MC NL PT SE TR
Designated Extension States:
LT LV RO

(72) Inventors:
• Auclair, Jean-Michel
36000 Chateauroux (FR)
• Daniel, Jean-Yves
36000 Chateauroux (FR)

(30) Priority: 10.08.2000 GB 0019755

(74) Representative: Hepworth, John Malcolm et al
Hepworth Lawrence Bryer & Bizley
Bloxam Court
Corporation Street
Rugby
Warwickshire CV21 2DU (GB)

(62) Document number(s) of the earlier application(s) in
accordance with Art. 76 EPC:
01957482.1 / 1 309 488

(71) Applicant: MeadWestvaco Packaging Systems
LLC
Stamford,
Connecticut 06905 (US)

Remarks:
This application was filed on 07 - 03 - 2006 as a
divisional application to the application mentioned
under INID code 62.

(54) Carton and insert and blank for forming the same

(57) A carton for packaging one or more articles comprising linear series of panels for forming a tubular structure comprising base panel, opposed side panels and a top panel, wherein the carton comprises an end closure panel hinged to one of said linear series of panels for at least partially closing one end of the tubular structure wherein said end closure panel comprises a hand aperture and wherein there further comprises an insert comprising a second hand aperture in registry with the first hand aperture, whereby the carton may be engaged by a user by the aperture formed in the carton by the first and second apertures.

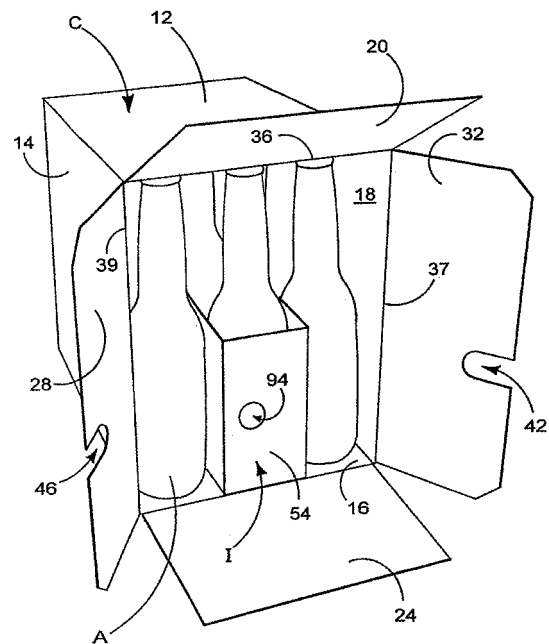

FIGURE 4

Description

Background of the Invention

[0001] The invention relates to a carton and blank for forming a carton for carrying a plurality of articles and an insert structure associated with the carton to provide additional protection to articles contained in the carton.

[0002] The use of an insert or partition in a carton is well known as a means to serve as a cushion between the articles and/or between the articles and the outer walls to protect them. In such known cartons, the insert is free to move in a vertical plane, which is undesirable because the insert will no longer serve as a cushion if moved in an upward position, for example between bottle necks.

[0003] Some inserts are formed from a unitary blank, which can reduce the rigidity of the erected insert. Examples of inserts formed from a single blank are shown in US 4 294 398 and US 5 529 240.

Summary of the Invention

[0004] The present invention seeks to overcome or at least mitigate the problems of the prior art.

[0005] A first aspect of the invention provides a carton for packaging one or more articles said carton comprising a linear series of panels for forming a tubular structure comprising a base panel, opposed side panels and a top panel, wherein the carton comprises an end closure panel hinged to one of said linear series of panels for at least partially closing one end of the tubular structure, said end closure panel comprising a first hand aperture, wherein the insert for insertion into the carton comprises a second hand aperture which is in registry with the first hand aperture when the insert is properly accommodated within the carton, so that a user may grasp and lift the carton by the first and second hand apertures.

[0006] Preferably, a carton wherein the end closure panel is secured to the insert.

[0007] Preferably, a carton wherein the carton comprises a further end closure panel hinged to a panel adjacent to said one of the linear series of panels, wherein the further end closure panel comprises a recess wherein the recess is in registry with the first and second apertures.

[0008] Preferably, a carton wherein there comprises a second further end closure panel opposed the further end closure panel wherein the second further end closure panel comprise a second recess whereby the second recess forms a composite aperture with the first recess wherein the composite aperture is in registry with the first and second apertures.

[0009] Preferably, a carton wherein the hand aperture may be used to engage a tear portion, the tear portion extending into the top panel, the tear portion forms an access means such that the contents of the carton may be accessed.

[0010] Preferably a carton wherein the tear portion extends into each of the opposed side panels.

[0011] Preferably, a carton wherein the top panel comprises a fold line, wherein the top panel may be folded along the fold line upon partial opening of the access means.

[0012] A second aspect of the invention provides a carton comprising an outer shell having a plurality of outer panels and an insert structure comprising a securing panel secured to one of the outer panels, a medial panel hingedly connected to the securing panel and a transverse partition panel foldably connected to the medial panel by a pair of spaced fold lines intermediate opposing ends of the transverse partition panel thereby to create a panel which extends outwardly from both sides of the medial panel when the insert structure is formed in a set up carrier.

[0013] Preferably, a carton wherein a second medial panel is hingedly connected to the securing panel, the securing panel extending between the first and second medial panels.

[0014] Preferably, a carton wherein the second medial panel is provided with a transverse partition panel hingedly connected thereto so as to be secured to the transverse partition panel of the first medial panel.

[0015] A third aspect of the invention provides a blank for forming a carton for carrying a plurality of articles comprising a top, bottom and opposing side wall panels hingedly connected together in series, an end panel hingedly connected to the base panel and an end flap hingedly connected to one of the side wall panels and a separate blank for forming an insert structure including a securing panel connected to a medial panel, wherein an aperture is provided in the end flap such that during construction of the carton glue is applied to an outer face of the securing panel and end flap to secure together the end panel, end flap and securing panel when placed together in face contacting relationship in a set up condition.

[0016] Preferably, a blank wherein the aperture is provided by a recess struck from the free side edge of the end flap.

[0017] Preferably, a blank wherein a second end flap is hingedly connected the other side wall panel and is provided with a recess in registry with the first recess such that the end panel is secured directly to the securing panel by application of glue to part of the securing panel on display through the first and second recesses.

[0018] Preferably, a blank wherein the insert structure further includes a transverse partition panel struck from the medial panel and foldably connected to the medial panel by a pair of spaced fold lines intermediate opposing ends of the transverse partition panel thereby to create a panel which extends outwardly from both sides of the medial panel when the insert structure is formed in a set up carrier.

[0019] A fourth aspect of the invention provides a blank for forming an insert structure comprising a medial panel

having a transverse partition panel foldably connected thereto by a pair of spaced fold lines intermediate opposing ends of the transverse partition panel thereby to create a panel which extends outwardly from both sides of the medial panel when the insert structure is formed in a set up carrier wherein the transverse partition panel comprises a first aperture suitable for engagement during construction of the insert structure.

[0020] Preferably, a blank wherein there comprises an end panel hinged to the medial panel wherein the end panel comprises a second aperture suitable for engagement during construction of the insert structure.

[0021] Preferably, a blank wherein the first and second apertures are in registry with one another when the insert structure is in a setup condition.

[0022] Preferably, a blank wherein the insert structure comprises a plurality of transverse partition panels, each comprising an aperture wherein the apertures are in registry with one another when the insert structure is in a setup condition.

[0023] A fifth aspect of the invention provides a package for carrying a plurality of articles, the package comprising a carton and an insert received in the carton, the carton comprising:

a pair of top and base panels hingedly interconnected by a pair of opposed side panels to form a tubular structure, and an end closure structure for at least partially, closing each of opposed ends of the tubular structure, each of the end closure structures comprising:

a top end flap hingedly connected to the top panel,
 a side end flap hingedly connected to each side panel,
 a base end flap hingedly connected to the base panel, and
 means for securing said flaps together,
 said top end flap having a first hand aperture,
 the insert being secured by the securing means to at least the top end flap,
 said insert having a second hand aperture that is sufficiently aligned with the first hand aperture in a top end flap on the same end of the carton so that a person's hand can be inserted through the first and second aligned apertures.

Brief Description of the Drawings

[0024] Exemplary embodiments of the invention will now be described, by way of example only, with reference to the accompanying drawings in which:

FIGURE 1 illustrates the blank for forming the outer carton according to a first embodiment of the invention;

FIGURE 2 illustrates the blank for forming the insert structure according to a first embodiment of the invention;

FIGURE 3 illustrates the insert structure in a set up condition formed from the blank shown in Figure 2;

FIGURE 4 shows the carton and insert structure in an erected and loaded condition with the articles;

FIGURE 5 illustrates the erected and loaded carton illustrated in Figure 4, with the end panels secured to the end flaps to complete its construction;

FIGURE 6 illustrates the blank for forming the outer carton according to a second embodiment of the invention;

FIGURE 7 illustrates the blank for forming the insert structure according to a second embodiment of the invention;

FIGURES 8, 9 and 10 illustrate the construction and loading of the carton from the blank of Figure 6;

FIGURE 11 illustrates the erected and loaded carton illustrated in Figure 10, with the end panels secured to the end flaps to complete its construction;

FIGURES 12 and 13 illustrate the carton with the lid removed;

FIGURE 14 illustrates the blank for forming the outer carton according to a third embodiment of the invention;

FIGURE 15 illustrates the blank for forming the insert structure according to a third embodiment of the invention;

FIGURES 16 and 17 illustrate the construction and loading of the carton from the blank of Figure 15;

FIGURE 18 illustrates the erected and loaded carton illustrated in Figure 17, with the end panels secured to the end flaps to complete its construction; and

FIGURE 19 illustrates the carton with the lid removed.

Detailed Description of the Preferred Embodiments

[0025] Referring to the drawings and in particular, Figures 1 and 2, there is shown one embodiment of a blank for forming a carton and a blank for forming an insert structure made from paperboard or similar foldable sheet material. It is envisaged that a unitary blank for the carton and insert structure could be used without departing from

the scope of invention. In the embodiments described below, the carton is a "fully-enclosed" type although it will be recognised that the invention could be applied to a "wraparound" type carton or "basket-type" carton where it is required to secure an insert structure to one of the outer panels.

[0026] Turning to the first embodiment shown in Figure 1, the blank 10 comprises a plurality of panels for forming the top, base and opposed side walls whereby there is shown a top panel 12, a first side wall panel 14, bottom panel 16 and second side wall panel 18 hingedly connected one to the next in series along fold lines 13, 15 and 17 respectively.

[0027] The ends of the carton are constructed by one or more end panels. In this embodiment, opposed end panels 20 and 22 are hingedly connected to the opposing ends of top wall panel 12 along fold lines 36 and 38 respectively. A second pair of end panels 24, 26 is provided along opposing end edges of base panel 16 and hingedly connected thereto along fold lines 36 and 38 respectively.

[0028] Preferably, a pair of end flaps 28, 30 is hingedly connected to first side wall panel 14 along opposing end edges and are connected thereto by fold lines 36, 38 respectively. Likewise, a second pair of end flaps 32, 34 are hingedly connected to side wall panel 18 along fold lines 36, 38 respectively. The end panels 20, 22; 32, 34 are usually secured to the end flaps, so that in use, the end flaps support the end walls to improve rigidity.

[0029] There may further comprise one or more recesses struck from end flaps. In use, the recess enables the insert structure I (Figure 4) to be secured to one or more of the end panels 20, 24, described below. In this embodiment, a pair of recesses 42, 46 are provided in end flaps 28, 32 that are positioned in corresponding positions along the opposing side edges, so as to marry up when the carton is erected. Preferably, a second pair or recesses 44, 48 is applied to the opposing end flaps 30, 34 so that the insert structure can be inserted from either end to be secured to the outer carton described in more detail below.

[0030] It is envisaged that the recess is not limited to the shape illustrated in Figure 1 and indeed could be replaced by other means to allow the insert structure to juxtapose the end panel. For example, end flap 28 could terminate at the lower edge of recess 46 or, alternatively one or more apertures could be struck from end flaps 28 and/or 32.

[0031] Turning to the construction of the insert structure, there comprises a blank 50, as shown in Figure 2, comprising one or more medial partition panels and a securing panel. There further comprises at least one transverse partition panel. Therefore, for a carton holding a group of four articles in a 2 x 2 arrangement, a single medial panel and transverse partition panel is required together with the end panel. Other arrangements are envisaged, so that for three rows of articles, two medial partition panels are provided.

[0032] In the illustrated embodiment, there comprises

a first medial partition panel 52, an end panel 54 and second medial partition panel 56 hingedly connected together along fold lines 58 and 60 and adapted to receive twelve articles in a 3 x 4 arrangement.

5 **[0033]** Figure 2 shows medial partition panel 52 is provided with three transverse partition panels 62a, 62b and 62c. Each transverse partition panel is similar and therefore only partition panel 62a is described in any greater detail.

10 **[0034]** Transverse partition panel 62a is connected to medial partition panel 52 along upper and lower fold lines 66a and 68a to create a panel that extends outwardly from both sides of the medial panel 52. It will be seen from Figure 2 that, in this embodiment, fold lines 66 and 68 are aligned in a vertical plane. The upper and lower edges of panel 62a are adapted to extend one side of the medial panel are defined by cut lines 76 and 78 respectively which separate the panel 62a from medial panel 52. Cut line 76 extends from the lower end of fold line 66 to the upper end of the upper fold line 66b connecting panel 62b to medial panel 52. Similarly, cut line 78 extends from the upper end of fold line 68 to the lower end of the lower fold line connecting panel 62b to medial panel 52.

25 **[0035]** Further cut lines 77 and 79 define respectively the upper and lower edges of the part of the transverse partition panel that will extend outwardly from the other side of the medial panel 52. The opposing side edges of transverse partition panel 62a are provided by cut lines 72 and 74 respectively and optionally, apertures 70a, 70b.

30 **[0036]** Adjacent one of the side edges 74 of partition panel 62a, there comprises a protruding portion 98 used to overlap the portion 96 of transverse panel 64a struck from the other medial partition panel 56 and described in more detail below.

35 **[0037]** The second medial partition panel is also provided with three transverse partition panels 64a, 64b and 64c. It will be seen that each transverse partition panel is similar and therefore only partition panel 64c is described in any greater detail.

40 **[0038]** Transverse partition panel 64c is similar to transverse partition panel 62a in that it is preferably adapted to extend outwardly on both sides of the medial panel 56. Thus, panel 64a is connected to medial partition panel 56 along fold lines 80c and 82c that are aligned in a vertical plane, in this embodiment. The upper and lower edges of panel 64a to extend one side of the medial panel are defined by cut lines 86 and 87 respectively which separate the panel 64a from medial panel 56. Cut line 86 extends from the upper end of fold line 82c to the lower end of the upper fold line 82b connecting panel 64b to medial panel 56. Similarly, cut line 87 extends from the lower end of fold line 80c to the upper end of lower fold line 80b connecting panel 64b to medial panel 56. A further cut line 84 is shaped to define the part that will extend outwardly from the other side of the medial panel 56. Cut line 84 also defines a protruding portion 96 used

to overlap the portion 98 struck from the transverse panel 62c of other medial partition panel 52 and described in more detail above.

[0039] There may further comprise a tab 92 and cut lines 90 extending from the end edge of transverse panel 64a. Additionally or alternatively, there may also comprise apertures 70 struck from medial panel 52. In use, they assist in causing the panels 62a, 64a to separate from the medial panels 52 and 56 respectively.

[0040] A plurality of apertures 88, 94 struck from each of the transverse partition panels 64a, 64b, 64c and a corresponding aperture 94 may be struck from end panel 54 may be provided: they are used by suitable machinery to open the transverse panels 64 during the mechanical construction of the insert structure.

[0041] Turning now to the second embodiment of the present invention, as illustrated in Figures 6 to 13 which is similar to the first embodiment and therefore, like numerals have been where possible used to denote like parts with the addition of the prefix "1". Only the differences between the first and second embodiments will be described in any greater detail.

[0042] In this embodiment, the recesses 142, 146 are provided at opposed and spaced positions in end flap 120, as shown in Figure 6. Furthermore the means to connect the outer panel to the insert structure is provided on one end of the carton only.

[0043] The blank is adapted to receive one or more articles, for example sachets and to be displayed within the carton by means of a display window formed by recesses in end panels 122 and 126. In order to gain access to the interior of the carton an access structure is provided, which in this embodiment is provided by a plurality of frangible lines. The frangible lines 101, 104, 102, and 108 are formed in the panels 134, 118, 120, 114 and 130 to define a removable cover. The cover is provided by panels 147 and 145 as well as end flap 122 top panel 112 and part of end flap 120. To assist in removing the cover an aperture and finger tab 143 are provided in end flap 120.

[0044] In some embodiments the cover is provided with a fold line 106, which is used to partially fold back the cover to reveal the contents of the carton.

[0045] The insert structure 150 is illustrated in Figure 7 and are placed intermediate the outer edges of the sachets and the outer walls to provide extra protection. In this embodiment there are opposed medial panels 152 and 156 and securing panel 154 hingedly connected together along fold lines 158 and 160, as shown in Figure 7.

[0046] Turning now to the third embodiment of the present invention, as illustrated in Figures 14 to 18 which is similar to the first embodiment and therefore, like numerals have been where possible used to denote like parts with the addition of the prefix "2". Only the differences between the first and third embodiments will be described in any greater detail.

[0047] It will be seen from Figure 14 that the construction of the end panels 224, 226; 220, 222 and end flaps

232, 234; 228, 230 is very similar to the first embodiment. The principal difference is that in this embodiment there is provided a handle structure. The handle is struck from top panel 212 by opposed cut lines 227a, 227b; 261a, 261b; 229a, 229b to define a handle strip H and is hingedly connected thereto along fold lines proximate a central portion of top panel 212.

[0048] Preferably the handle strip H extends into the adjacent side or end walls. In this embodiment, the handle strip extends into side wall panels 218 and 214 and is hingedly connected thereto along fold lines 221 and 223 respectively. The handle strip is separated from side wall panels 218 and 214 by extensions of cut lines 227 and 229 respectively that terminate at the ends of fold lines 221 and 223. There may further comprise hand support flaps 265 hingedly connected to opposed side edges of handle strip H.

[0049] The insert blank 250 is illustrated in Figure 15 and, again, is placed intermediate the outer edges of the sachets and the outer walls to provide extra protection. In this embodiment there are opposed medial panels 252 and 256 and securing panel 254 hingedly connected together along fold lines 258 and 260, as shown in Figure 15.

[0050] The insert blank 250 is also provided with additional flaps 251 and 257. In use the flaps envelop the sachets to be held in position as they are loaded into the carton.

[0051] Turning to the construction of the carton from any of the carton blanks illustrated in Figures 1, 6 or 14 and the insert structure from the insert blanks illustrated in Figure 2, 7 or 15 each blank requires a series of sequential folding and gluing operations which are preferably performed in a straight line machine, so that the carton and blank are not required to be rotated or inverted to complete its construction. The folding process is not limited to that described below and can be altered according to particular manufacturing requirements.

[0052] Dealing with the construction of the insert structure I of the first embodiment from the blank 50, shown in Figure 2, the medial partition panels 52 and 56 are folded out of alignment from securing panel 54 along fold lines 58, 60 to be placed in a substantially perpendicular arrangement, whereby the medial partition panels 52 and 56 are substantially parallel and in a spaced arrangement. To construct the individual cells O (shown in Figure 3), the transverse partition panels 62 and 64 are moved out of alignment with medial partition panels 52 and 56 respectively. Turning first to transverse partition panel 62c, the panel is folded along fold lines 66c and 68c so that the protruding portion 98 is folded inwardly on one side of the medial panel 52. It will be seen that the transverse partition panel 62c is caused to pivot about fold lines 66c and 68c so that the panel extends from both sides of the medial panel 52. Preferably, the transverse partition panel 62c is substantially perpendicular to the medial panel 52. Likewise, transverse partition panels 62a and 62b are formed in a like manner.

[0053] Transverse partition panels 64a, 64b, 64c are formed in a like manner whereby panel 64c is folded out of alignment with medial panel 56 along fold lines 80c and 82c and is caused to pivot so that the transverse panel 64c extends from both sides of the medial panel 56 in a substantially perpendicular relationship with respect to it. Protruding portion 96 extends inwardly and comes into abutment with corresponding protruding portion 98. Preferably, the corresponding protruding parts 96, 98 are secured together by glue or other suitable means known in the art which creates a rigid insert structure I. Panels 64b and 64a are formed in a like manner and shall therefore not be described in any greater detail. Thus, the insert structure is in a set up condition as shown in Figure 3. It will be seen that there are twelve cells O formed to separate and support the articles in adjacent cells.

[0054] The insert structure I is ready to receive the articles, which are loaded by relative vertical movement between the articles A and the insert structure I during forward feed movement. The articles enter their respective cells through the open bottom of the insert structure. Alternatively, the articles can enter their respective cells through the top of the insert structure I.

[0055] The outer carton C is constructed by folding top panel 12, first side wall panel 14, base panel 16 and second side wall panel 18 out of alignment with each other along fold lines 13, 15 and 17 to be folded into a tubular structure, shown in Figure 4. Top panel 12 and side panel 18 are secured together by securing flap 40. In those embodiments with securing flap 40, it is secured to side panel 18 by folding along fold line 41 to be secured to the side panel 18 by glue or other suitable means known in the art.

[0056] The carton is at an intermediate stage of construction whereby the articles and insert structure are inserted into the carton C from one of the ends. It will be seen from Figure 4 that the end panels 20 and 24 and end flaps 28 and 32 are folded outwardly along fold line 36 to guide the articles and insert structure into the carton. Preferably, the opposing end wall is formed prior to receiving the articles whereby end flaps 30 and 34 are folded inwardly along fold lines 31 and 39 respectively. Thereafter, end wall panels 22 and 26 are folded inwardly along fold lines 35 and 38 to be secured to the end flaps 30 and 32 by glue or other suitable means known in the art. Thus, the carton is at the stage illustrated in Figure 4.

[0057] In order to complete construction of the carton C, the insert structure I should be secured to one of the end wall panels 20 or 24. To this end, the end flaps 28 and 32 are folded inwardly along fold line 36 so that a portion of the end flaps 28, 32 come into abutment with the end wall 54 of insert structure I, and the recesses 42 and 46 are aligned, as shown in Figure 5.

[0058] End wall panel 20 is folded downwardly along fold line 36 and is, optionally, secured to the end flaps 28 and 32 by glue or other suitable means known in the art. Alternatively, the end wall 20 is held in place by end

wall panel 24, which is secured to the end flaps described below. Thereafter, the lower end wall panel 24 is folded inwardly along fold line 33 and secured to the end flaps 28 and 32 by glue, such as glue strip G2, or other suitable means known in the art. In order to secure the insert structure I to end wall panel 24, a strip of glue G1 is, in this embodiment, applied in a substantially straight line intermediate opposing side edges of the end flaps such that the glue is applied through recesses 42, 46 to the insert structure.

[0059] In alternative embodiments, glue may be applied to different areas of the blank such as where apertures are used instead of the recess. By folding the end wall panel 24 inwardly, it is secured in face contacting relationship with the end flaps 28 and 32 and, the part of the insert structure I revealed by the recesses 42, 46. In this way, the insert structure I is secured directly to an outer wall of the carton by the application of glue in a standard method i.e. using a straight line gluing gun. Thus, the carton is in a set up condition.

[0060] The construction of the carton of the second embodiment is similar to the first embodiment in that the outer carton C is constructed by folding top panel 112, first side wall panel 114, base panel 116 and second side wall panel 118 out of alignment with each other along fold lines 113, 115 and 117 to be folded into a tubular structure, shown in Figure 8. Base panel 116 and side panel 18 are secured together. In those embodiments with securing flap 140, it is secured to side panel 118 by folding along fold line 142 to be secured thereto by glue or other suitable means known in the art.

[0061] The insert structure is inserted into the carton, as shown in Figure 8, which helps to brace the outer carton and maintain it in a set up condition. Thereafter the articles are loaded into the carton and the end flaps 130 and 134 and end panels 122, 126 are folded inwardly and secured together to define a display window, as shown in Figure 9.

[0062] Figure 10 shows the opposing end wall formed in like manner to the first embodiment whereby end wall panel 120 is folded downwardly along fold line 136 and is, optionally, secured to the end flaps 128 and 132 by glue or other suitable means known in the art. Thereafter, the lower end wall panel 124 is folded inwardly along fold line 133 and secured to the end flaps 128 and 132 by glue, such as glue portions G, or other suitable means known in the art. In order to secure the insert structure to end wall panel 124, a strip of glue G is, in this embodiment, applied in a substantially straight line intermediate opposing side edges of the end flaps such that the glue is applied through recesses 42, 46 to the insert structure.

[0063] By folding the end wall panel 124 inwardly, it is secured in face contacting relationship with the end flaps 128 and 132 and, the part of the insert structure revealed by the recesses 142, 146. In this way, the insert structure is secured directly to an outer wall of the carton by the application of glue in a standard method i.e. using a straight line gluing gun. Thus, the carton is in a set up

condition as shown in Figure 11.

[0064] In order to remove the cover to gain access to the interior of the carton, as shown in Figures 12 and 13, the user pulls on the pull tab and tears the cover from the carton by tearing along the frangible lines 102, 113, 115, 104, 108, 101 and 103, to separate it as shown in Figure 13, thereby to reveal the articles A.

[0065] Turning to the third embodiment illustrated in Figures 16, the outer carton is formed and loaded in an identical manner to that described above. In this embodiment the insert structure is attached to the outer panels of the end walls at each end. This is achieved by the provision of flaps, 251 and 257 which appear through the recesses 242, 246, as shown in Figure 17. Thereafter the end wall 226 is secured directly to one or both of panels 251, 257 by the application of glue in a standard method.

[0066] The handle is constructed when the user pushes the hand flaps inwardly to reveal the handle strip shown in Figure 18. Lifting the handle strip will separate it from the top and side walls because of the cut lines 227, 229 and 261. The handle strip is hinged to the top panel 212 by step panels 267, which pivot about their hinged connections between the handle strip H and the side walls 218 and 214 to dissipate some of the load from lifting the handle.

[0067] In order to gain access to the interior of the carton shown in Figure 19, there is provided a cover panel struck from top panel 212 and hinged to end wall panel 222. Cover panel is frangibly connected to top and side walls by frangible lines 227, 229 and 225 which separates it from the respective panels to reveal the articles contained in the carton.

[0068] The present invention and its preferred embodiment relates to an arrangement for securing together the outer end panels and at least one panel of an insert structure, however it is anticipated that the invention can be applied to a variety of carriers and is not limited to those of the fully enclosed type hereinabove described and could be used for numerous applications where it is desired to secure a separate blank to an outer carton in a face contacting relationship in which a single application of glue is used.

[0069] It will be recognised that as used herein, directional references such as "top", "base", "end", "side", "inner", "outer", "upper" and "lower" do not limit the respective panels to such orientation, but merely serve to distinguish these panels from one another. Any reference to hinged connection should not be construed as necessarily referring to a single fold line only: indeed it is envisaged that hinged connection can be formed from one or more of one of the following, a score line, a frangible line or a fold line, without departing from the scope of invention.

[0070] It should be understood that various changes may be made within the scope of the present invention, for example, the size and shape of the panels and apertures may be adjusted to accommodate articles of differ-

ing size or shape, alternative top and base closure structures may be used. A single glue aperture may be provided in some embodiments. The carton may accommodate more than one article in different arrays. Additional panel(s) may be provided between the main and transverse article receiving panels so as to form a curved interface there between.

Statements of Invention

[0071] A package for carrying one or more articles comprising a carton having a plurality of wall panels for forming a tubular structure wherein each end of the carton is closed by a first panel hingedly connected to one of the wall panels, an intermediate panel hingedly connected to another wall panel of the carton and adapted to be placed such that at least part of said intermediate panel is disposed in face contacting relationship with the inner face of the first panel, there further comprises within the carton an insert structure associated with one or more articles, the insert structure including a second panel, wherein an aperture or recess is provided in the intermediate panel such that glue applied to an outer face of the second panel and the intermediate panel secures together said first, second and intermediate panels when placed together at least partially in a face contacting relationship to close an end of the carton.

[0072] A package wherein the intermediate panel is provided by an end flap and the aperture is provided by a recess struck from the free side edge of the end flap.

[0073] A package wherein a second end flap is provided with a recess in registry with the first recess such that the first panel is secured directly to the second panel by the application of glue to that part of the second panel on display through the first and second recesses.

[0074] A package wherein the insert structure further includes a medial panel hingedly connected to the second panel and disposed along said other wall panel.

[0075] A package wherein the insert structure further includes a second medial panel disposed along a still another wall panel disposed opposite to said other wall panel, said first and second medial panels hingedly connected to opposite side edges of said second panel respectively.

[0076] A package wherein a transverse partition panel is foldably connected to said first medial panel by a pair of spaced fold lines intermediate opposing ends of the transverse partition panel thereby to create a panel which extends outwardly from both sides of said first medial panel when the insert structure is formed in a set up carrier.

[0077] A package wherein the second medial panel is provided with a transverse partition panel hingedly connected thereto so as to be secured to the transverse partition panel of the first medial panel.

[0078] A package wherein one or more of the wall panels are defined by a frangible connection to facilitate detachment of part of the package to define a display win-

dow with access to the articles contained therein.

[0079] A package wherein there further comprises a handle struck from and hingedly secured to one or more of the wall panels.

Claims

1. A carton and an insert together for packaging one or more articles said carton comprising a linear series of panels for forming a tubular structure comprising a base panel, opposed side panels and a top panel, wherein the carton comprises an end closure panel hinged to one of said linear series of panels for at least partially closing one end of the tubular structure, said end closure panel comprising a first hand aperture, wherein the insert for insertion into the carton comprises a second hand aperture which is in registry with the first hand aperture when the insert is properly accommodated within the carton, so that a user may grasp and lift the carton by the first and second hand apertures.

5

a medial panel hingedly connected to the securing panel and a transverse partition panel foldably connected to the medial panel by a pair of spaced fold lines intermediate opposing ends of the transverse partition panel thereby to create a panel which extends outwardly from both sides of said medial panel when the insert structure is formed in a set up carrier.
2. A carton according to claim 1 wherein the end closure panel is secured to the insert.

10

9. A carton as claimed in claim 8 wherein a second medial panel is hingedly connected to the securing panel, the securing panel extending between the first and second medial panels.
3. A carton according to either of claims 1 or 2 wherein the carton comprises a further end closure panel hinged to a panel adjacent to said one of said linear series of panels, wherein said further end closure panel comprises a recess wherein the recess is in resisting with the first and second apertures.

15

10. A carton as claimed in claim 9 wherein the second medial panel is provided with a transverse partition panel hingedly connected thereto so as to be secured to the transverse partition panel of the first medial panel.
4. A carton according to claim 3 wherein there comprises a second further end closure panel opposed said further end closure panel wherein the second further end closure panel comprise a second recess whereby said second recess forms a composite aperture with the first recess wherein the composite aperture is in resisting with the first and second apertures.

20

11. A blank for forming a carton for carrying a plurality of articles comprising a top, bottom and opposing side wall panels hingedly connected together in series, an end panel hingedly connected to the base panel and an end flap hingedly connected to one of said side wall panels and a separate blank for forming an insert structure including a securing panel connected to a medial panel, wherein an aperture is provided in the end flap such that during construction of the carton glue is applied to an outer face of the securing panel and end flap to secure together said end panel, end flap and securing panel when placed together in face contacting relationship in a set up condition.
5. A carton according to any preceding claims wherein the hand aperture may be used to engage a tear portion, said tear portion extending into the top panel, the tear portion forms an access means such that the contents of the carton may be accessed.

25

12. A blank as claimed in claim 11 wherein the aperture is provided by a recess struck from the free side edge of the end flap.
6. A carton according to claim 5 wherein the tear portion extends into each of the opposed side panels.

30

13. A blank as claimed in claim 12 wherein a second end flap is hingedly connected the other side wall panel and is provided with a recess in registry with the first recess such that the end panel is secured directly to the securing panel by application of glue to part of the securing panel on display through the first and second recesses.
7. A carton according to claim 5 wherein the top panel comprises a fold line, wherein the top panel may be folded along said fold line upon partial opening of the access means.

35

14. A blank as claimed in any of claims 11 to 13 wherein the insert structure further includes a transverse partition panel struck from the medial panel and foldably connected to the medial panel by a pair of spaced fold lines intermediate opposing ends of the transverse partition panel thereby to create a panel which extends outwardly from both sides of said medial panel when the insert structure is formed in a set up carrier.
8. A carton comprising an outer shell having a plurality of outer panels and an insert structure comprising a securing panel secured to one of the outer panels,

40

15. A blank for forming an insert structure comprising a medial panel having a transverse partition panel fold-
- 45
- 50
- 55

ably connected thereto by a pair of spaced fold lines intermediate opposing ends of the transverse partition panel thereby to create a panel which extends outwardly from both sides of said medial panel when the insert structure is formed in a set up carrier wherein the transverse partition panel comprises a first aperture suitable for engagement during construction of the insert structure. 5

16. A blank as claimed in claim 15 wherein there comprises an end panel hinged to the medial panel wherein the end panel comprises a second aperture suitable for engagement during construction of the insert structure. 10

17. A blank as claimed in claim 16 wherein the first and second apertures are in registry with one another when the insert structure is in a setup condition. 15

18. A blank as claimed in any of claims 15 to 17 wherein the insert structure comprises a plurality of transverse partition panels, each comprising an aperture wherein the apertures are in registry with one another when the insert structure is in a setup condition. 20

19. A package for carrying a plurality of articles, the package comprising a carton and an insert received in the carton, the carton comprising: 25

a pair of top and base panels hingedly interconnected by a pair of opposed side panels to form a tubular structure, and an end closure structure for at least partially, closing each of opposed ends of the tubular structure, each of the end closure structures comprising: 30

a top end flap hingedly connected to the top panel, 35

a side end flap hingedly connected to each side panel, 40

a base end flap hingedly connected to the base panel, and

means for securing said flaps together, said top end flap having a first hand aperture, 45

the insert being secured by the securing means to at least the top end flap,

said insert having a second hand aperture that is sufficiently aligned with the first hand aperture in a top end flap on the same end of the carton so that a person's hand can be inserted through the first and second aligned apertures. 50

55

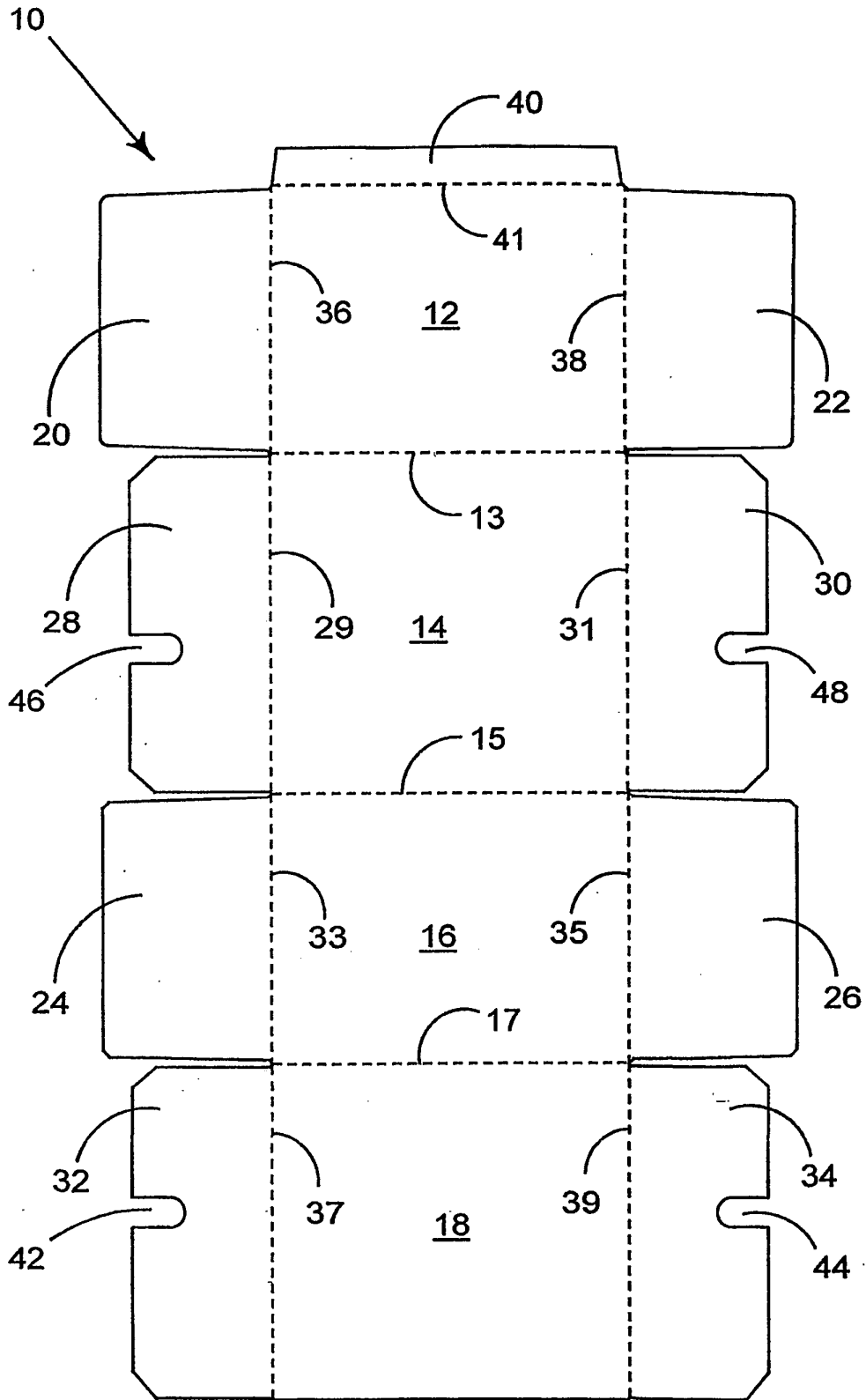

FIGURE 1

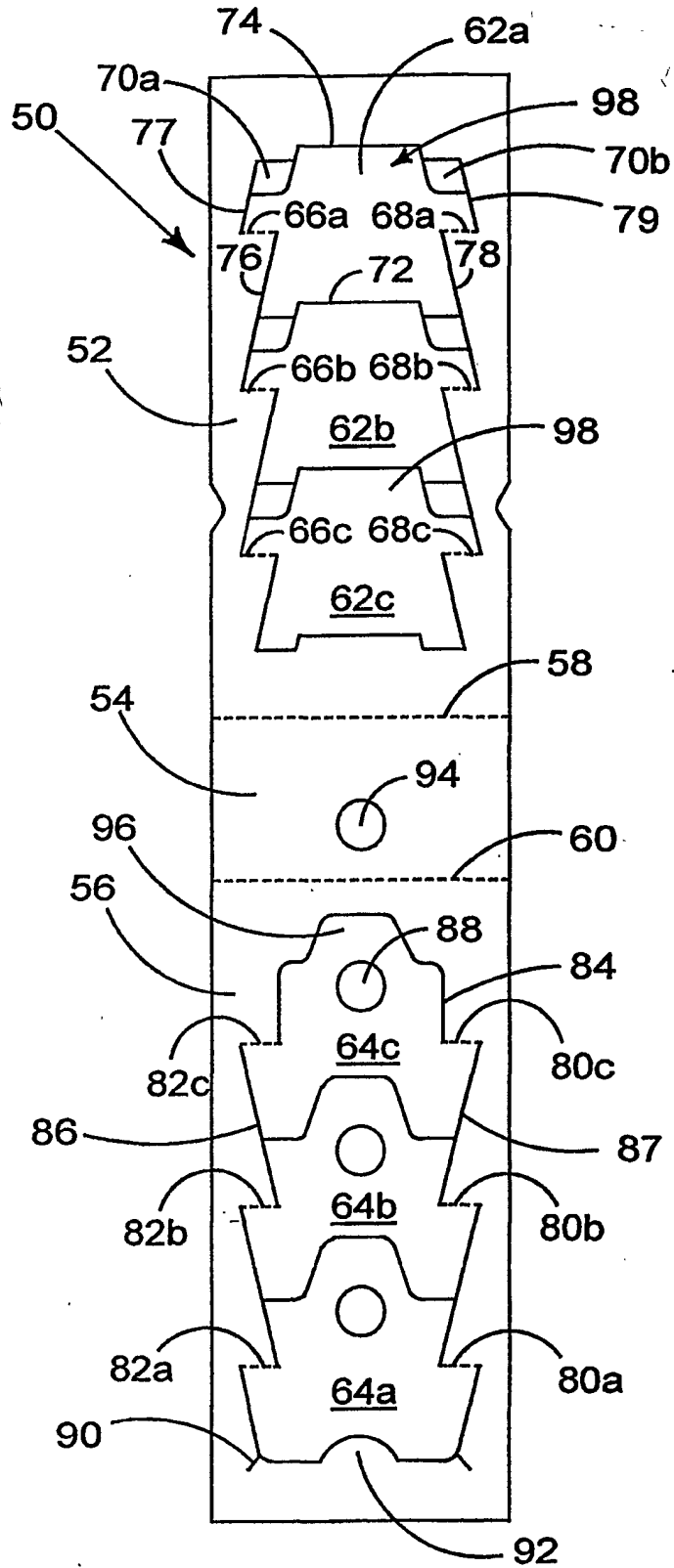

FIGURE 2

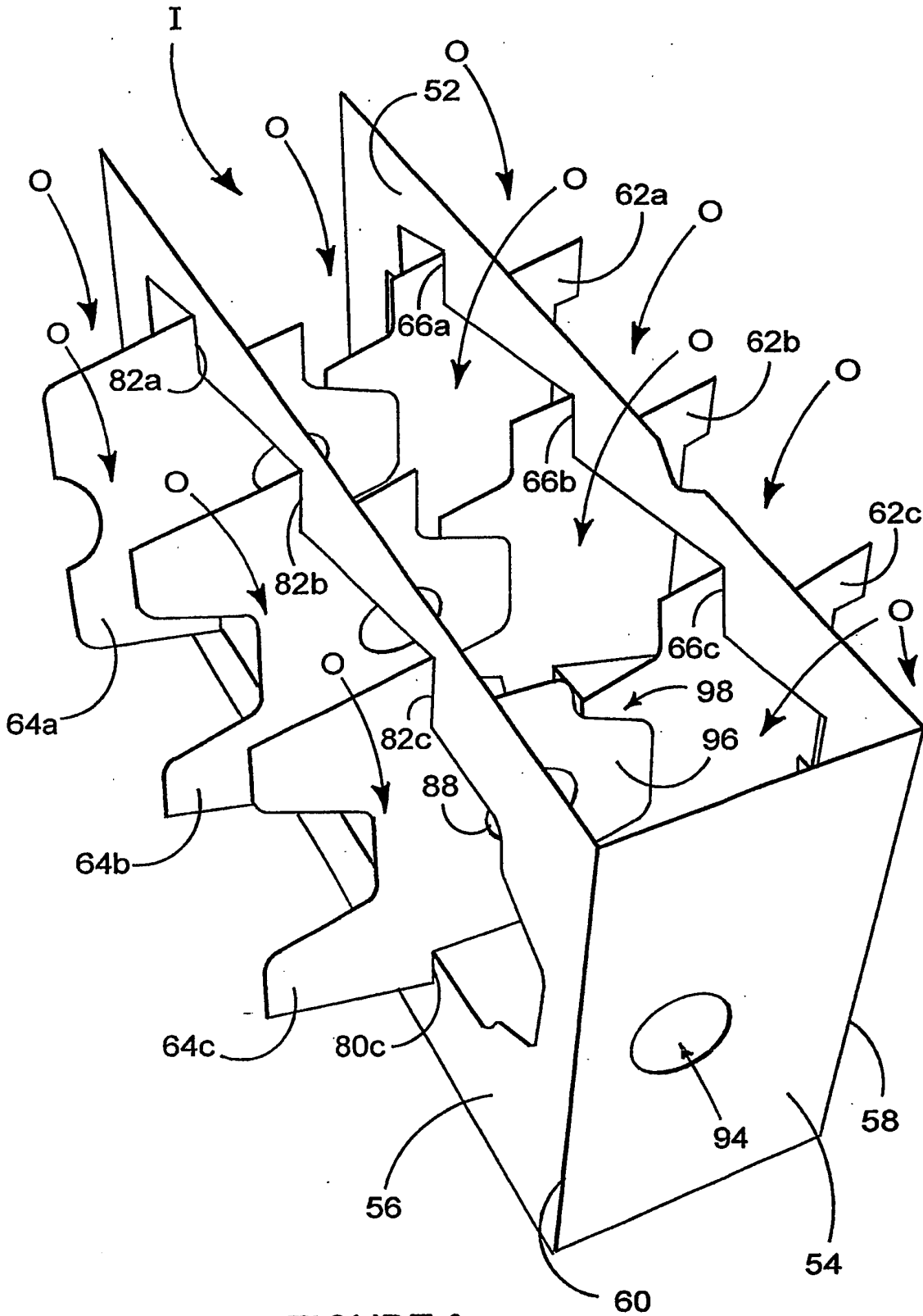

FIGURE 3

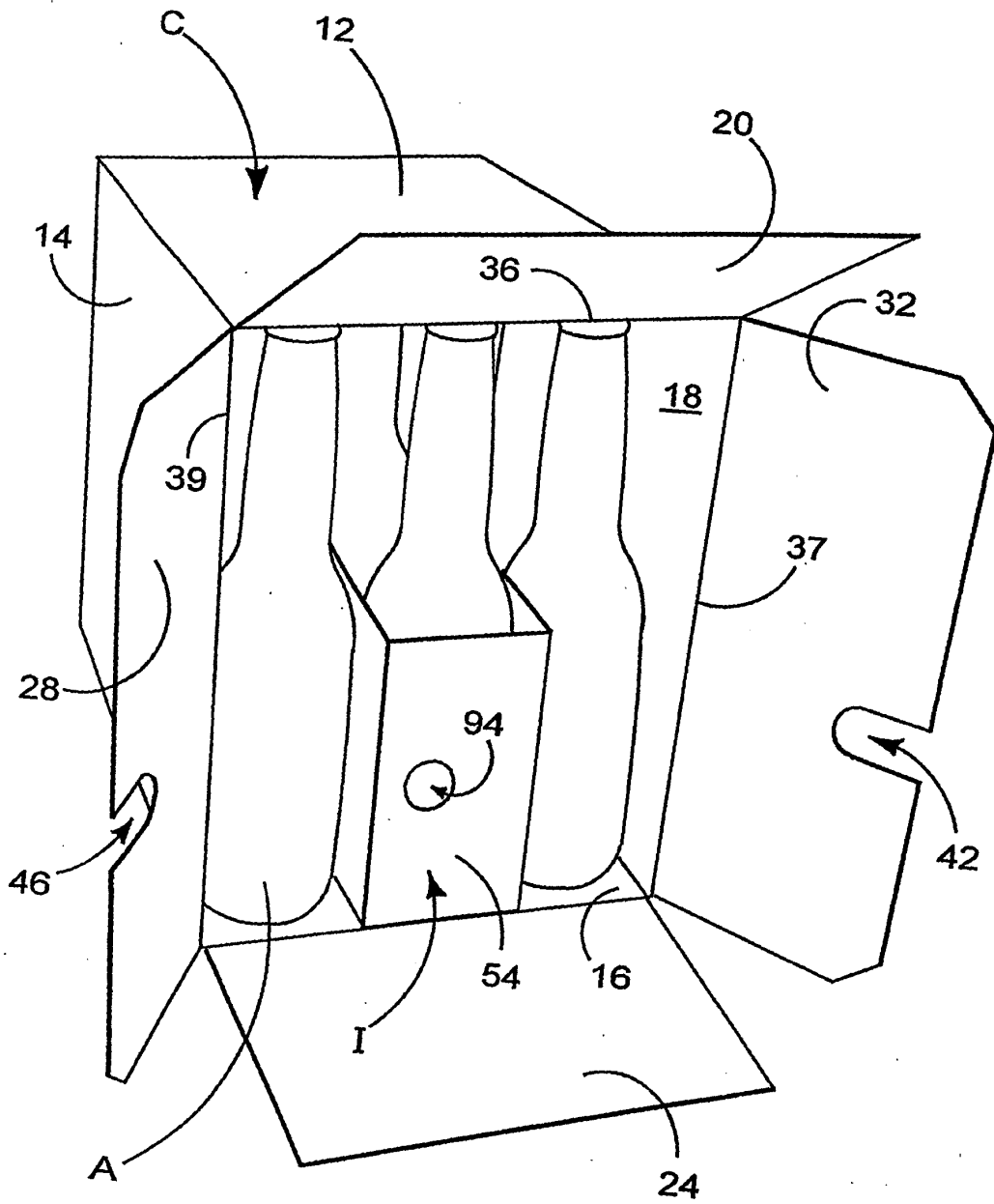

FIGURE 4

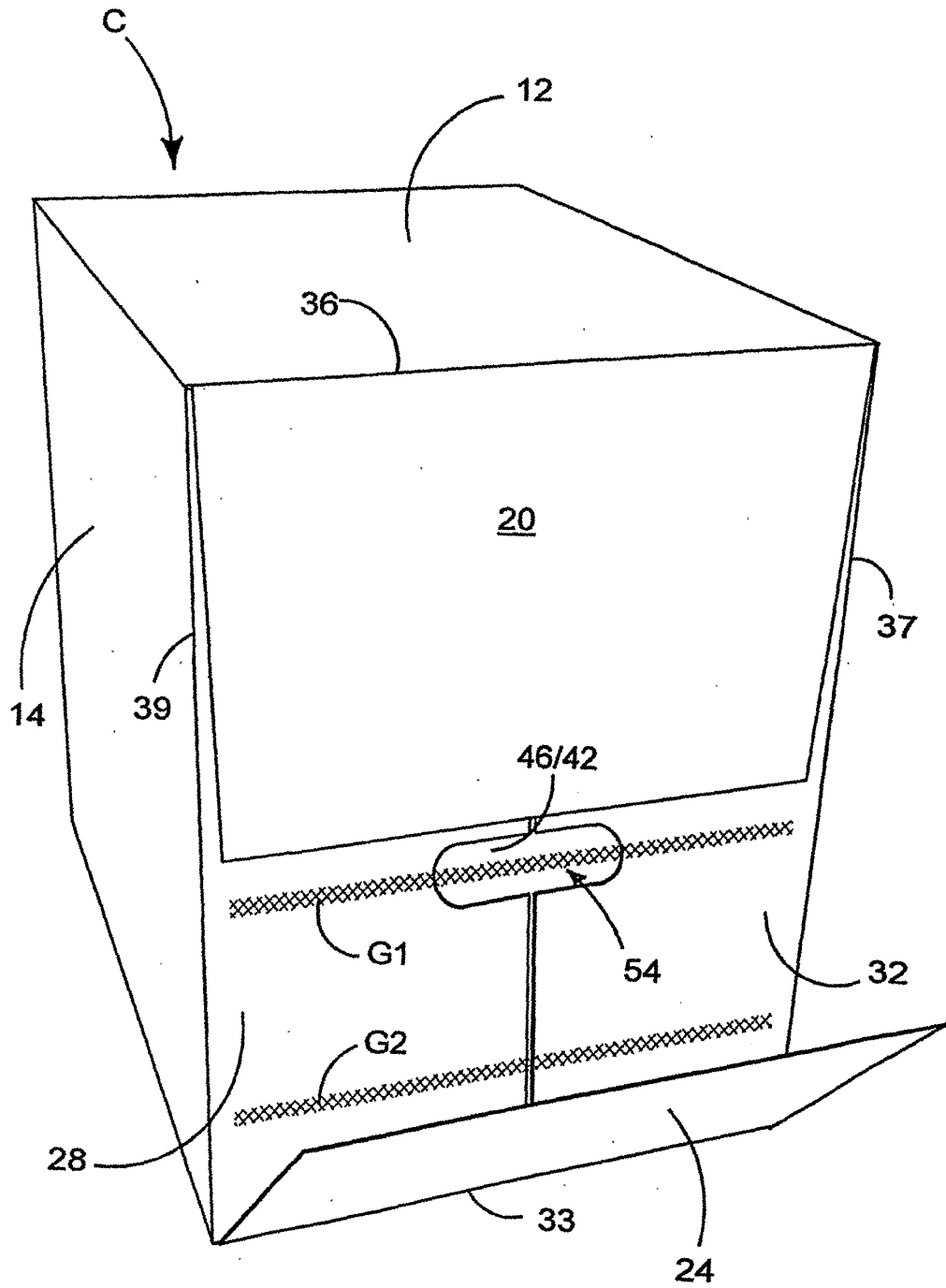

FIGURE 5

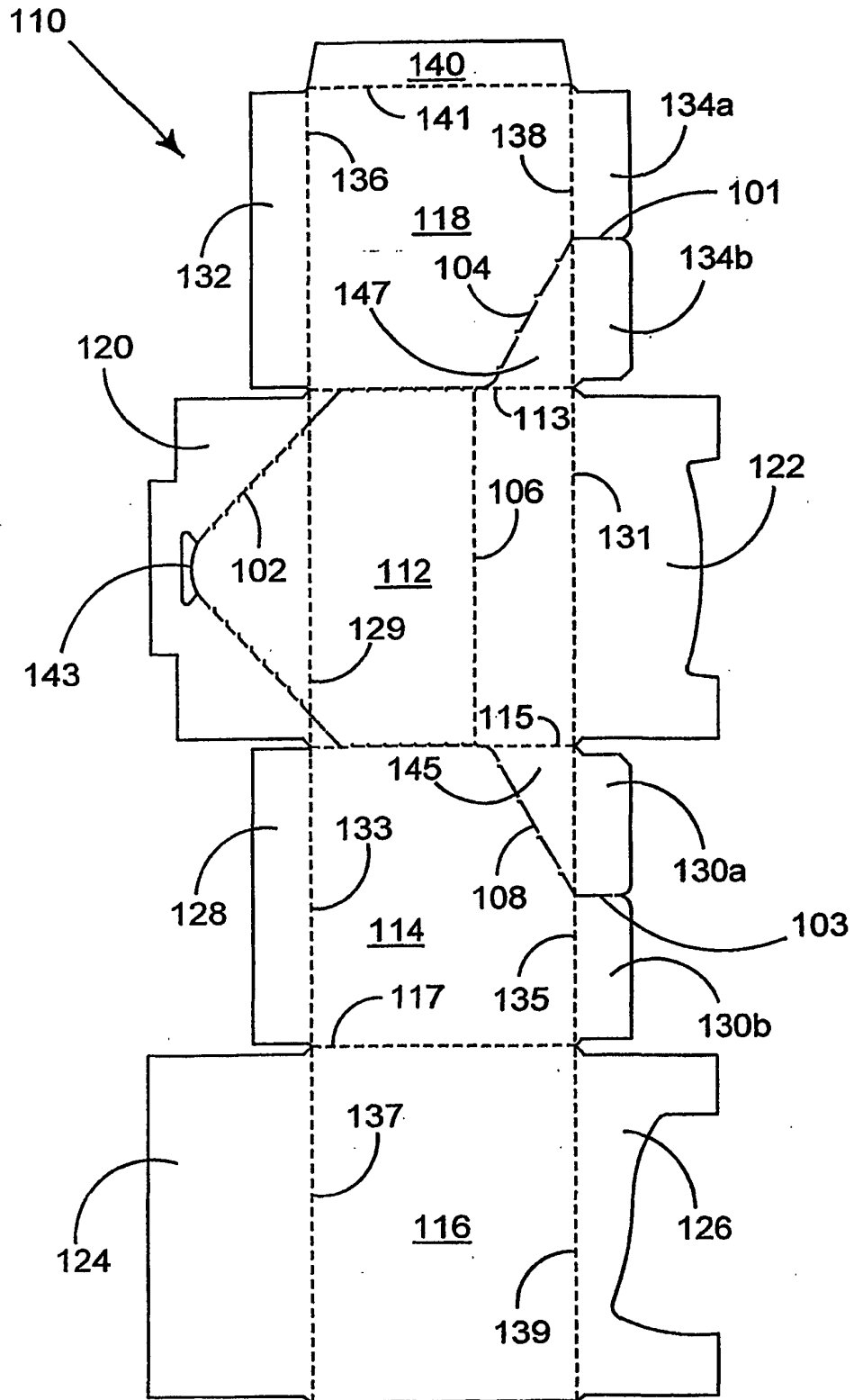

FIGURE 6

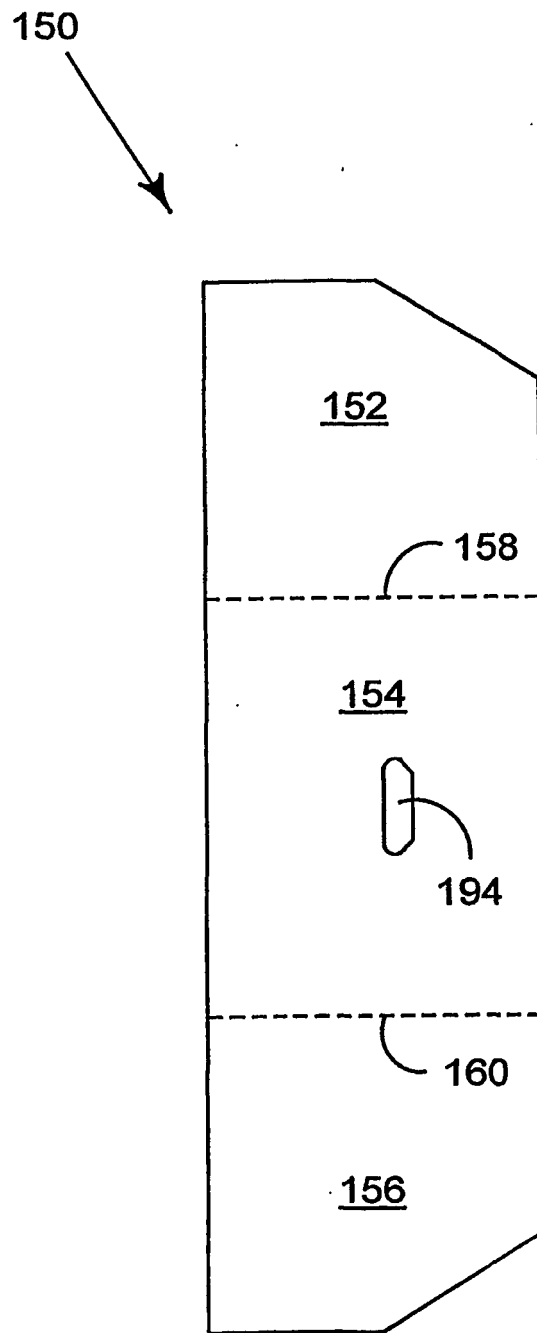

FIGURE 7

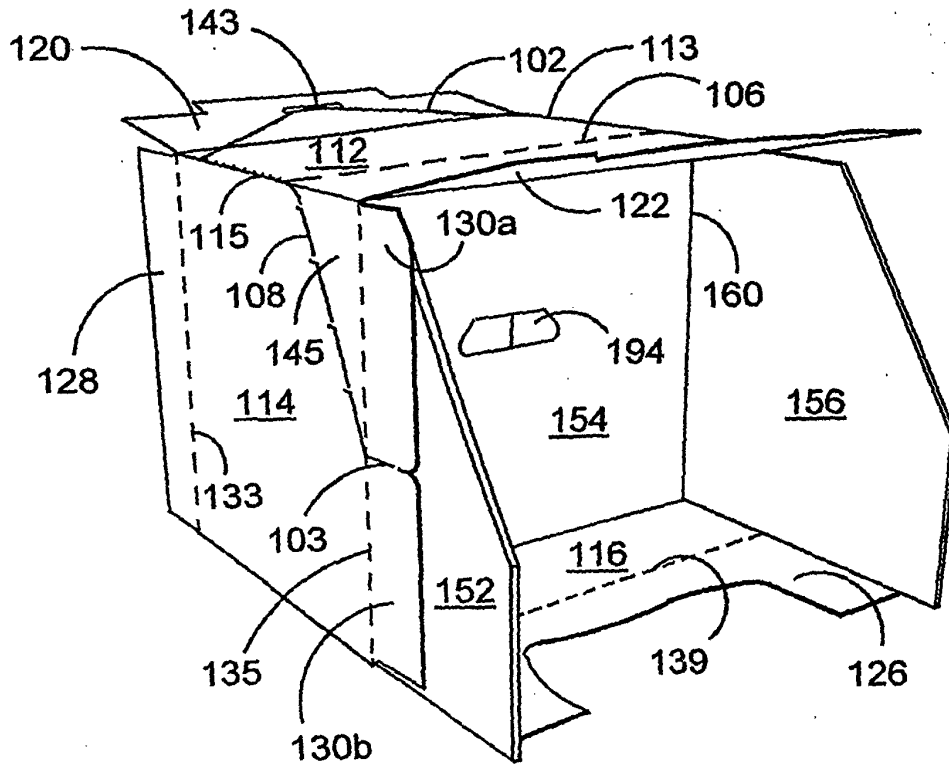

FIGURE 8

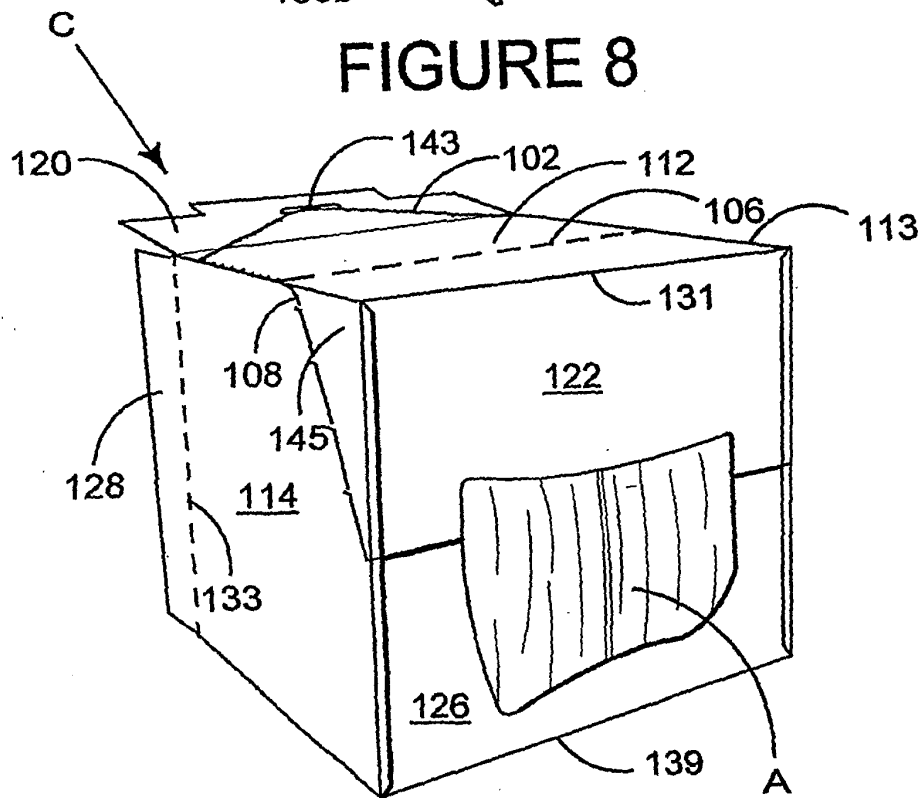

FIGURE 9

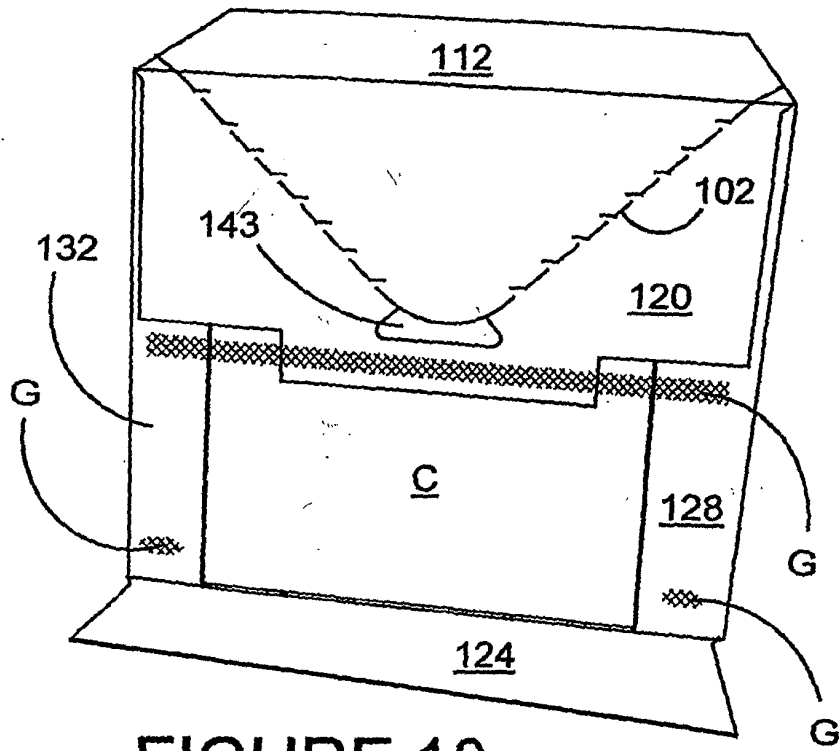

FIGURE 10

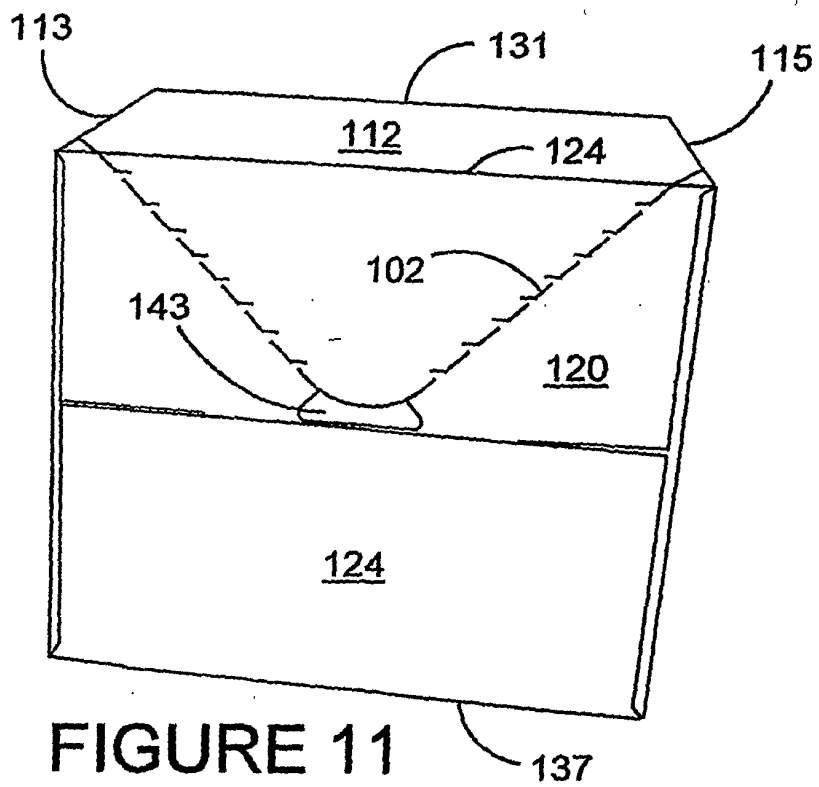

FIGURE 11

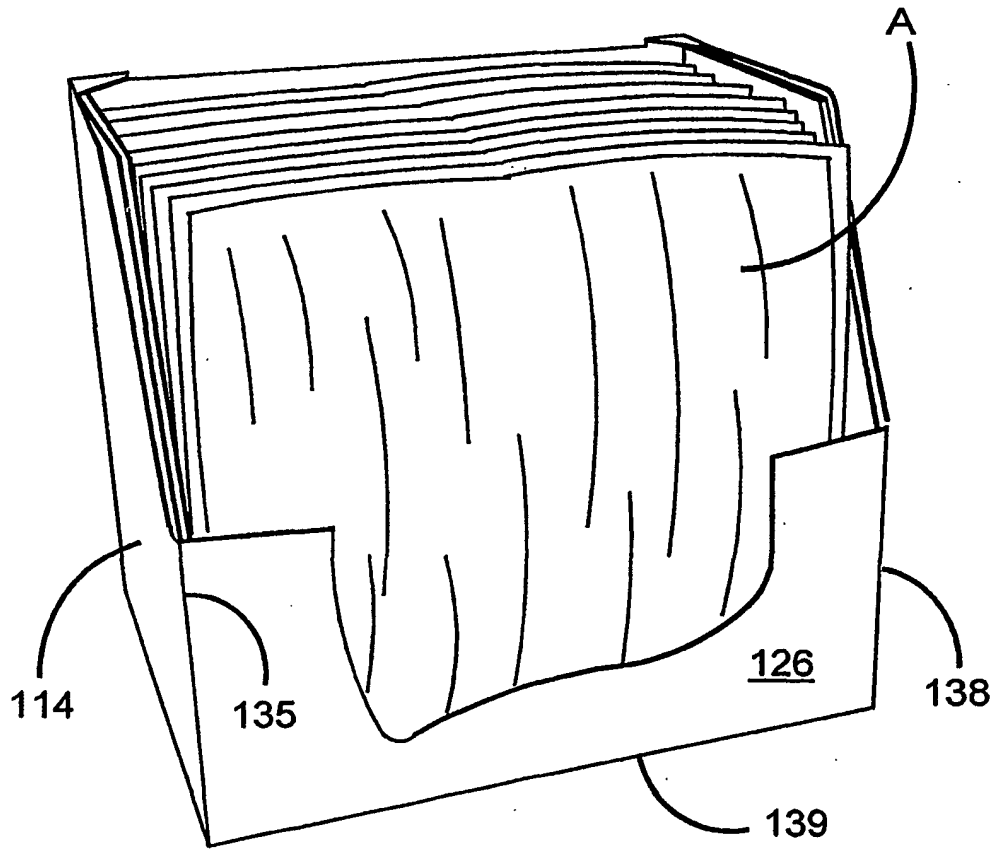

FIGURE 12

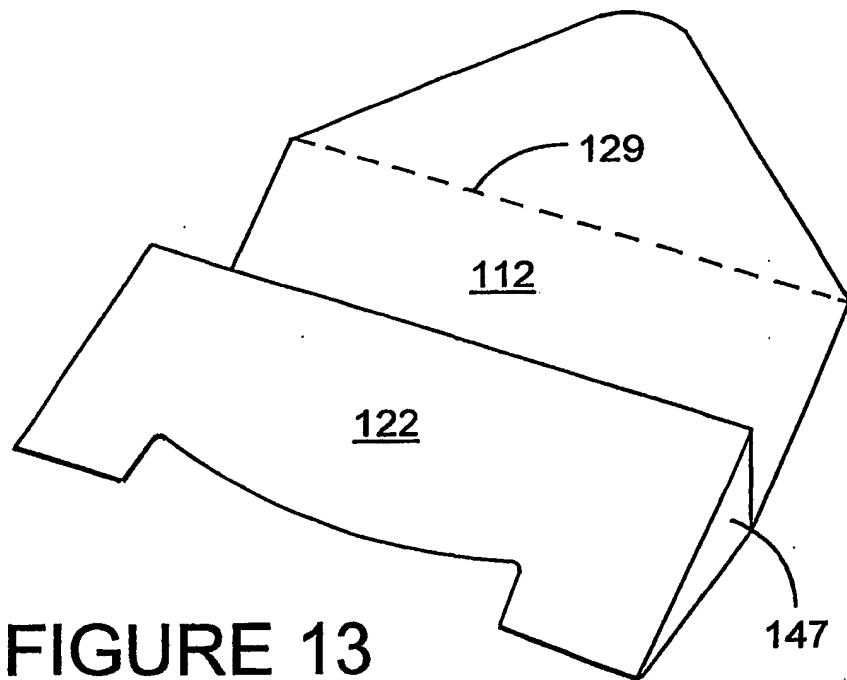

FIGURE 13

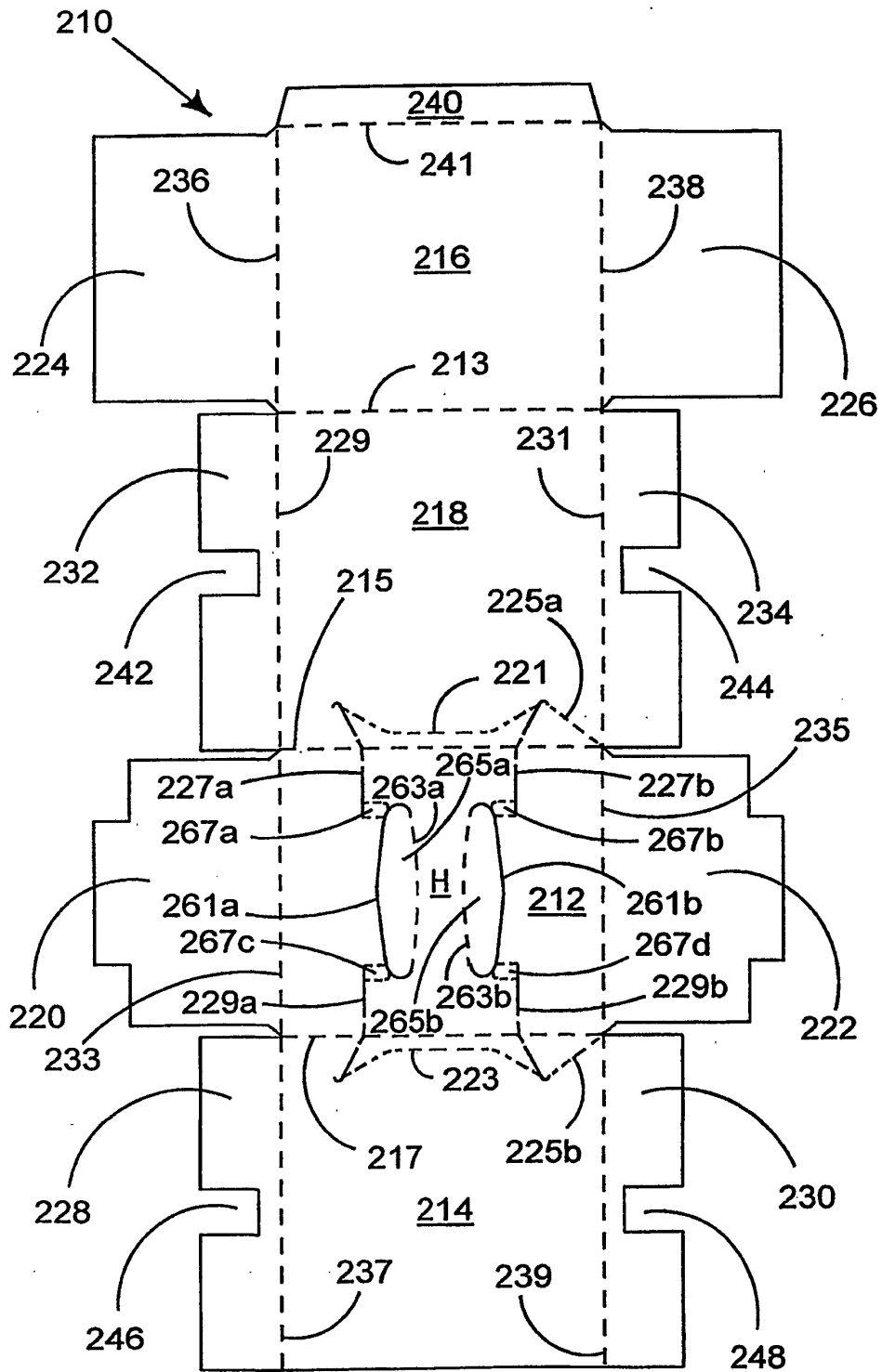

FIGURE 14

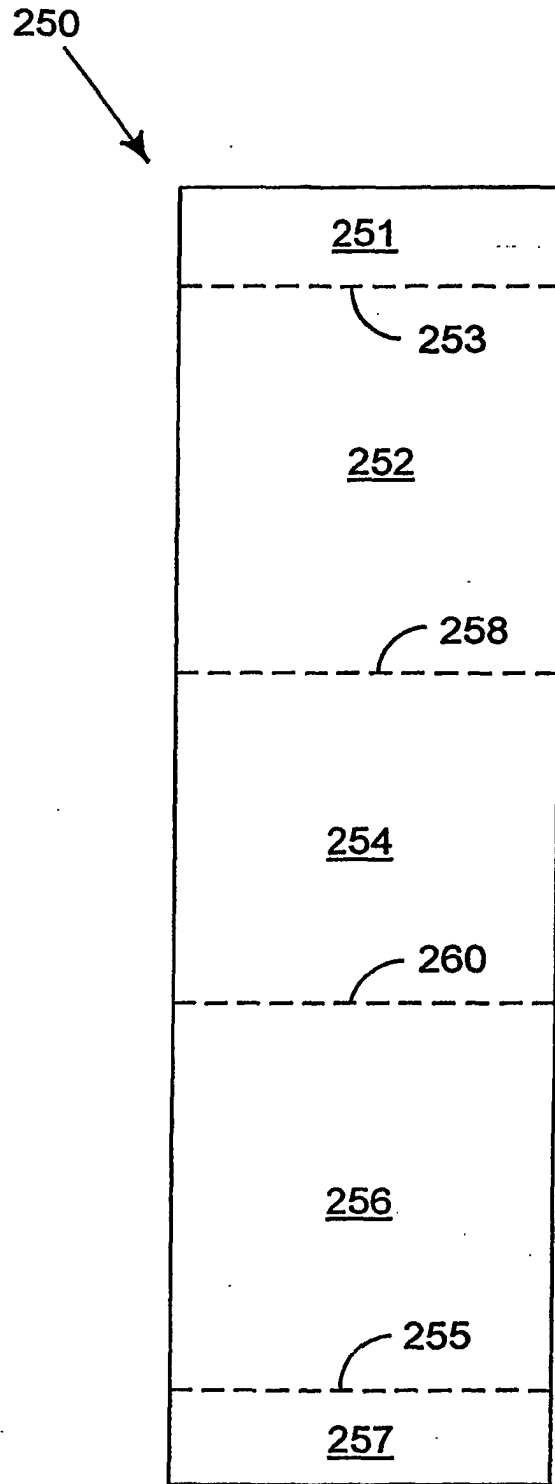

FIGURE 15

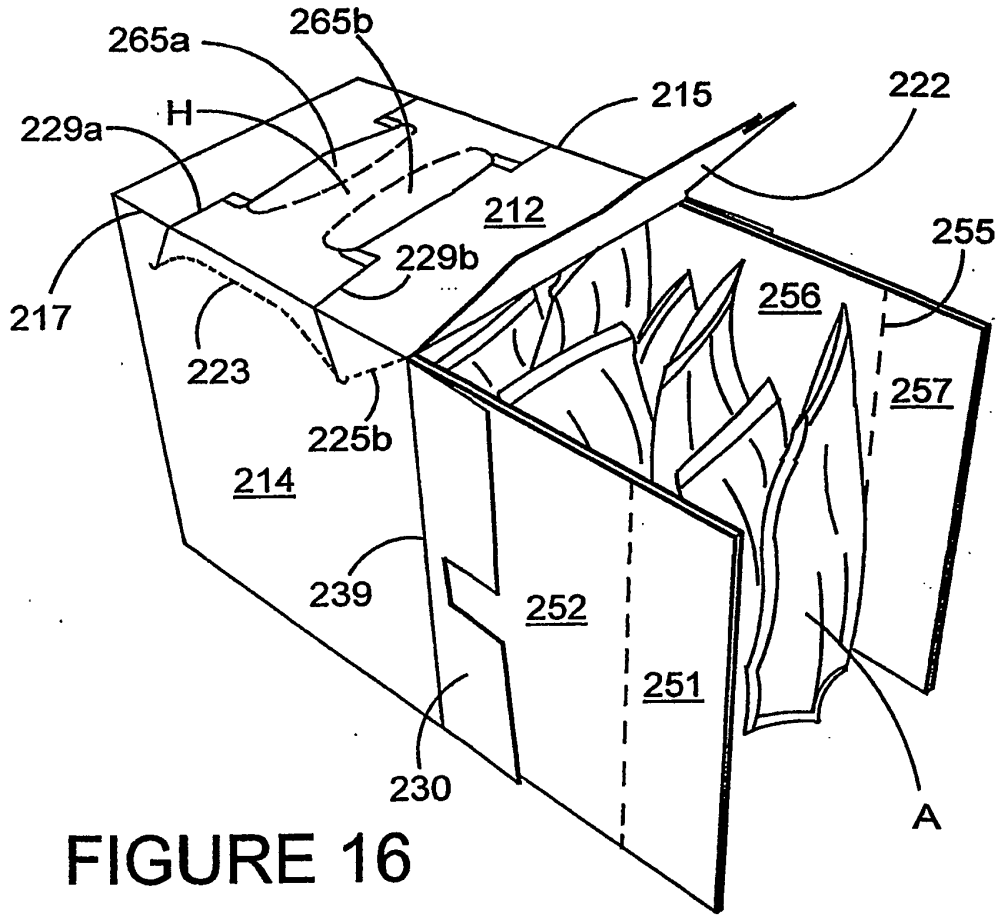

FIGURE 16

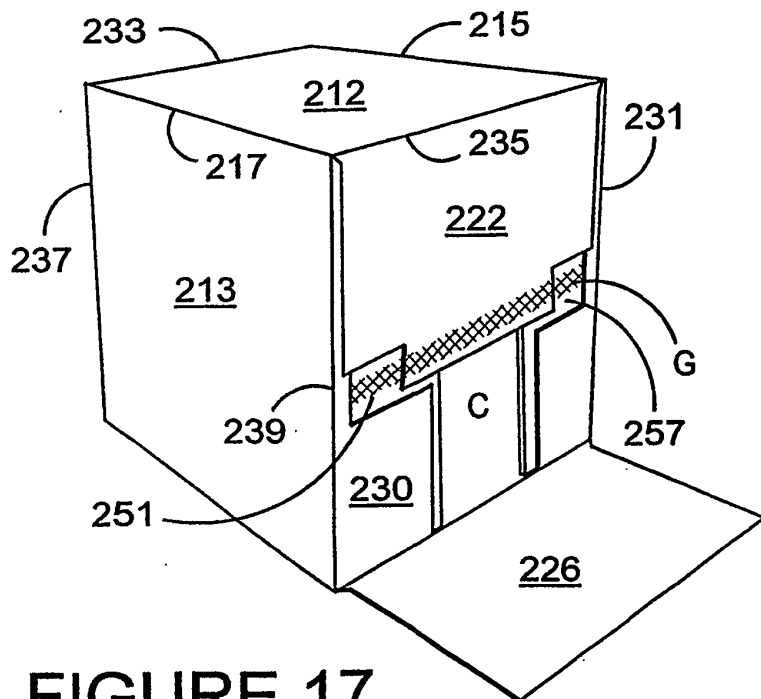

FIGURE 17

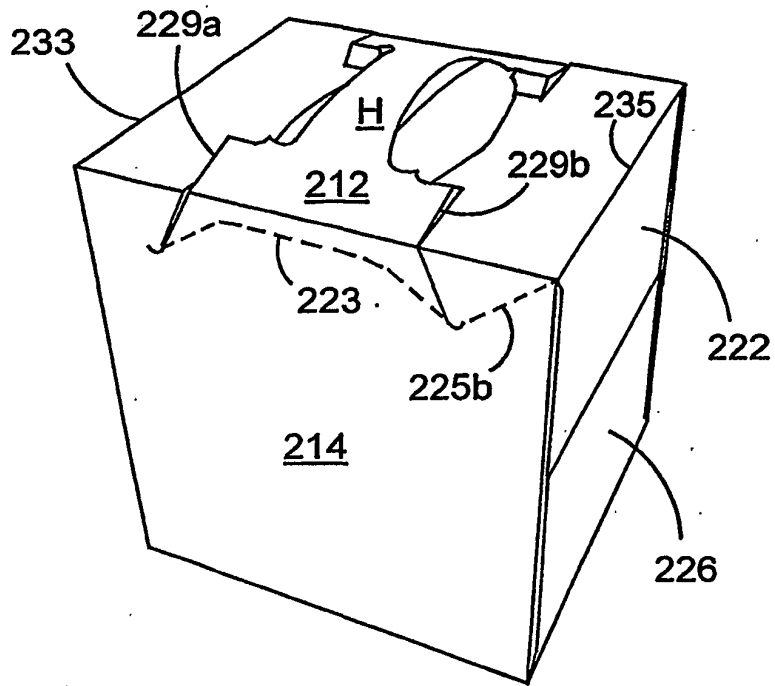

FIGURE 18

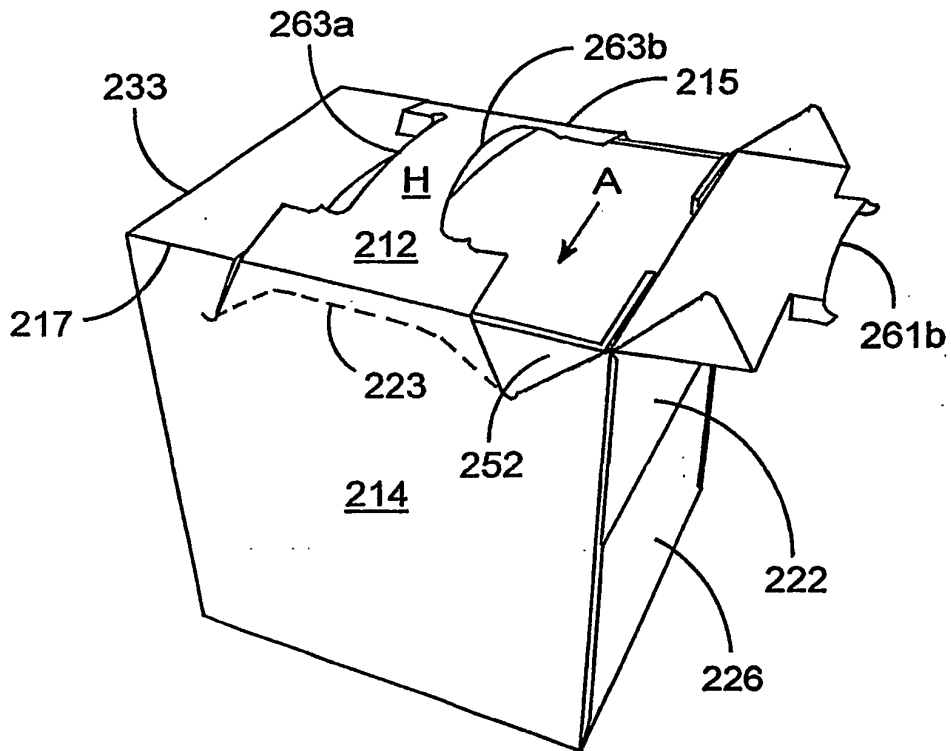

FIGURE 19