



US 20080188334A1

(19) **United States**

(12) **Patent Application Publication**
Feeney et al.

(10) **Pub. No.: US 2008/0188334 A1**

(43) **Pub. Date: Aug. 7, 2008**

(54) **GAME BALL WITH URETHANE GUM RUBBER SURFACE**

Related U.S. Application Data

(63) Continuation of application No. 09/479,985, filed on Jan. 10, 2000, now abandoned.

(75) Inventors: **Brian Feeney**, Enfield, CT (US);
Thomas J. Kennedy, Wilbraham, MA (US); **R. Dennis Nesbitt**, Westfield, MA (US)

Publication Classification

(51) **Int. Cl.**
A63B 41/10 (2006.01)

Correspondence Address:
FAY SHARPE LLP
1100 SUPERIOR AVENUE, SEVENTH FLOOR
CLEVELAND, OH 44114 (US)

(52) **U.S. Cl.** **473/605**

(73) Assignee: **Spalding Sports Worldwide, Inc.**, Chicopee, MA (US)

(57) **ABSTRACT**

A game ball having a highly durable cover exterior formed of a urethane gum rubber compound. The urethane material of the cover exterior is a cross-linked molded rubber material which provides superior abrasion resistance compared to ball covers made from a molded natural rubber.

(21) Appl. No.: **10/724,952**

(22) Filed: **Dec. 1, 2003**

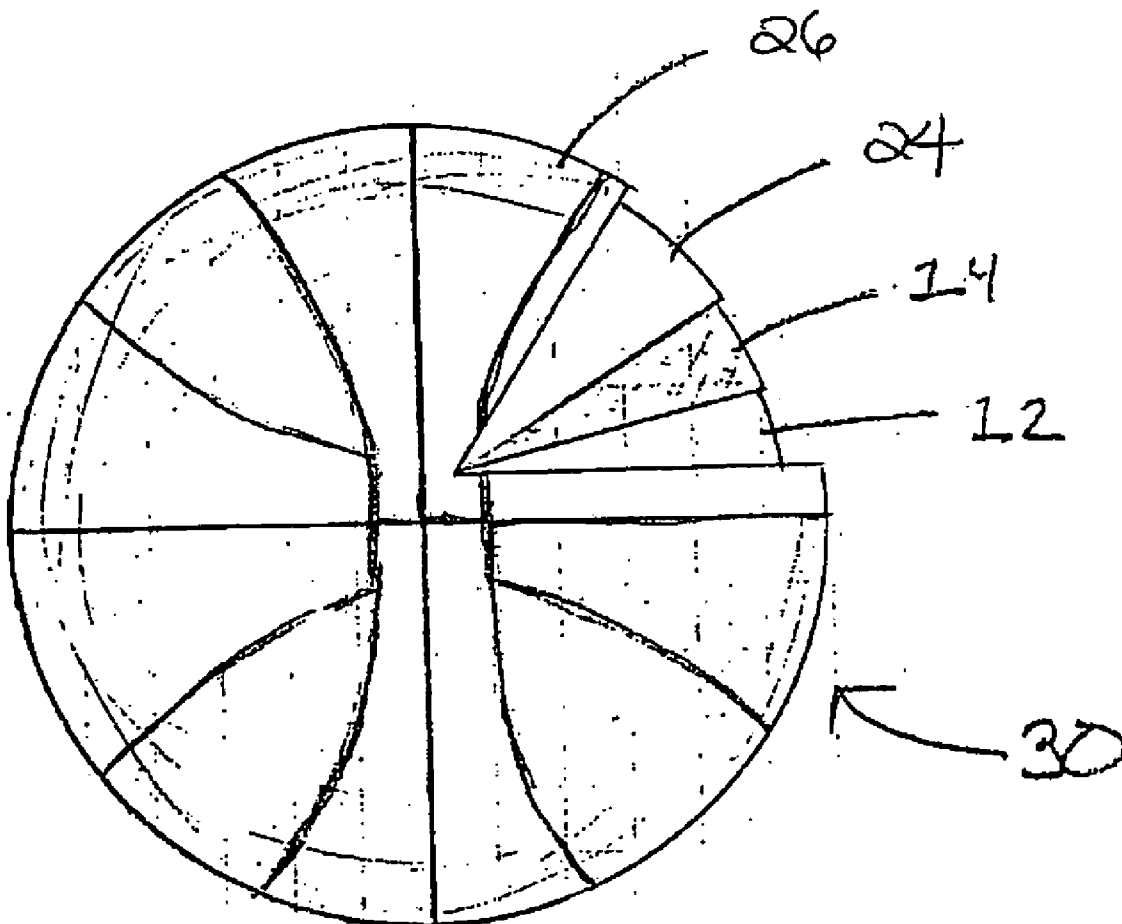

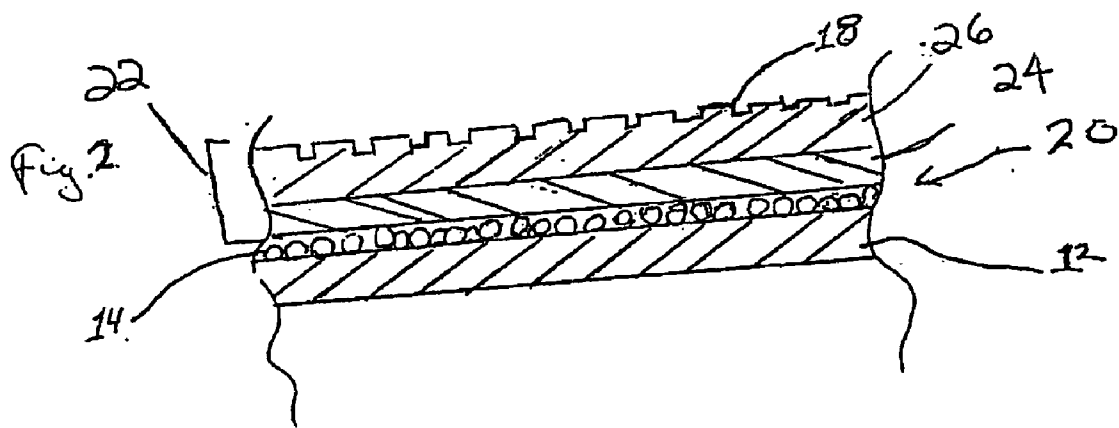
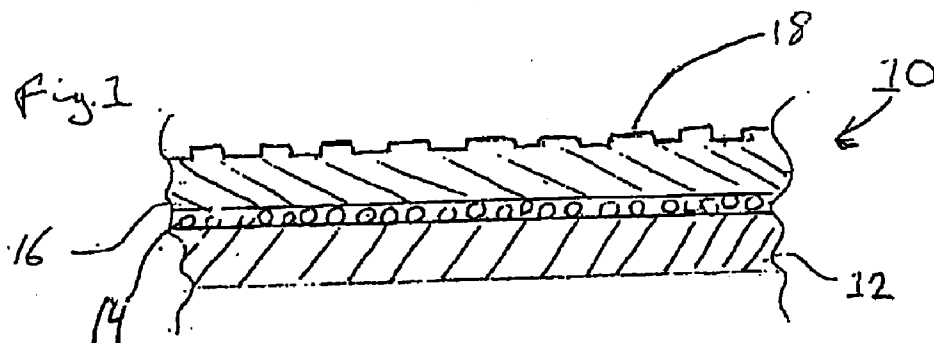

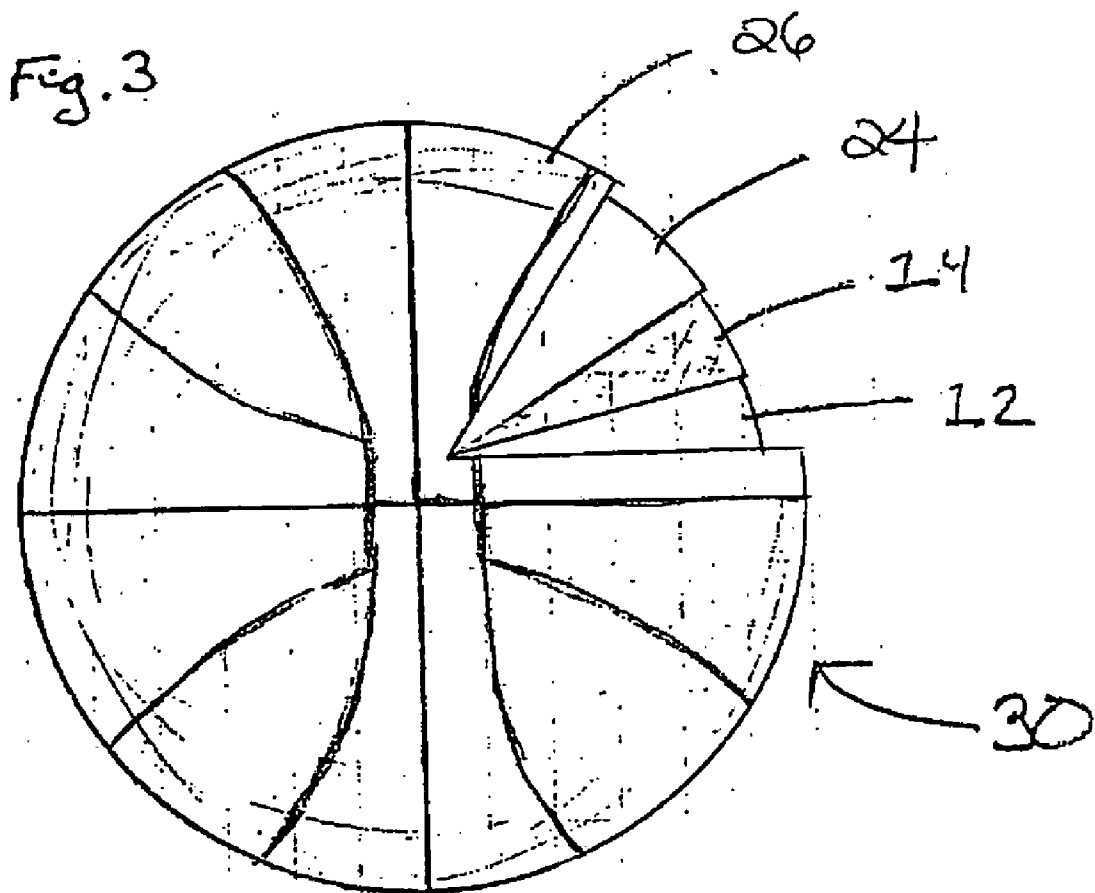

GAME BALL WITH URETHANE GUM RUBBER SURFACE

FIELD OF THE INVENTION

[0001] The present invention relates generally to game balls and more particularly is directed to game balls having a urethane gum rubber surface which provides for improved durability of the ball.

BACKGROUND OF THE INVENTION

[0002] Traditionally, game balls are made with an outer cover of leather. With a sport such as basketball, when played exclusively in a gymnasium on a finished wooden floor, or football, which is played on a grass covered field, the durability of a leather covered game ball is not a critical factor. However, when these and other sports are played on a paved surface such as is present in playgrounds, residential driveways, parking lots, or even in the street, the leather cover of the game ball wears excessively from contact with the abrasive paved playing surface.

[0003] The game ball industry has developed balls featuring covers formed from molded materials such as rubber or polyvinyl chloride (PVC) to improve ball wear. In addition, synthetic leather covers have been developed which closely simulate the appearance and feel of a natural leather cover, while providing greater durability than could be provided by natural leather.

[0004] Game balls which have covers made of molded natural rubber or PVC are often formed with a pebbled surface texture resembling a pebble-grained leather. When such balls are used on a paved playing surface the pebble texture tends to wear away leaving the surface of the ball smooth, slick and difficult for the player to handle. A small amount of dust on either the hands of the player or on the surface of the worn ball may dramatically increase the slipperiness of the ball. Likewise, perspiration on the hands of the player or water on the surface of the worn ball increase the slipperiness of the ball as well.

SUMMARY OF THE INVENTION

[0005] An object of the present invention is to provide a game ball with improved wear resistance.

[0006] Another object of the present invention is to provide a game ball with improved wear resistance and with play performance characteristics which are similar to the play performance characteristics of a game ball with a natural rubber cover.

[0007] These and related objects are achieved by providing a game ball with a cover formed of a urethane gum rubber composition. The urethane gum rubber is a raw rubber, based on polyurethane, which is subjected to a cross-linking process (vulcanization) during and after forming operations. The cured urethane rubber composition has a cross-linked structure similar to that of vulcanized natural rubber, but exhibits abrasion resistance many times greater than natural rubber compounds. When used in the cover of a game ball the ball exhibits very high durability with a high resistance to abrasion and wear as experienced in normal use.

[0008] The cover of the ball is formed by molding the urethane gum rubber in place over the substructure of the ball and subjecting the molded ball to conditions to promote the cure and cross-linking of the urethane gum rubber. The compositions of the cover optionally include other materials, such

as fillers, coloring pigments or dyes, cross-linking promoters, processing aids and cure accelerators.

[0009] A urethane gum rubber cover may be applied to any game ball. However, such a cover has particular utility when used in connection with basketballs, footballs, softballs, baseballs, and generic play balls for use on paved surfaces. It is envisioned that other game balls may advantageously use the urethane gum rubber compositions for their respective covers.

[0010] The invention accordingly comprises the several steps and the relation of one or more of such steps with respect to the others and the article possessing the features, properties, and relation of elements as exemplified in the following detail disclosure.

DESCRIPTION OF THE DRAWINGS

[0011] FIG. 1 is a sectional view of the cover of a game ball made according to the invention.

[0012] FIG. 2 is a sectional view of the cover of a game ball made according to a second embodiment of the invention in which the cover has multiple layers.

[0013] FIG. 3 is a view of a basketball, partially broken away and partially in section, according to the second embodiment of the invention which features a multiple layer covering.

DETAILED DESCRIPTION OF THE INVENTION

[0014] For clarity of description and ease of understanding, the invention will be described in connection with basketballs. It will be understood that other game balls including balls with various core structures which may include solid cores, hollow cores, wound cores, air-filled bladders and even air filled balls which have no bladder can advantageously employ the features of the present invention. Furthermore, in the figures similar structures in the several drawings will be identified with the same numbers.

[0015] With reference to FIG. 1, the basketball 10 includes a bladder 12 for holding air, a reinforcing layer of monofilament windings 14 which wrap around the bladder 12 and help the ball maintain its shape, and a cover layer 16 of a urethane gum rubber which surrounds and encloses the winding wrapped bladder. The bladder 12 is typically made of, for example, a butyl rubber composition including halo-butyl rubber (chloro or bromo-butyl rubber), or other similar resilient, stretchable material for holding air. The bladder 12 has a generally spherical shape and is equipped with a valve or other structure (not shown) for permitting air under pressure to be introduced to the interior of the bladder 12 for inflation and pressurization.

[0016] The wound reinforcing layer 14 is typically formed of monofilaments of polyester and/or nylon and is wrapped around the bladder 12 in either a pre-determined pattern or a random fashion to help the ball 10 retain spherical shape under typically inflation pressure and under the stresses of use. The windings 14 are coated with an adhesive which allows them to adhere to the bladder 12 and also to each other to ease the winding process. The bladder 12 is ordinarily fully or partially pressurized to maintain a spherical shape while the wrappings are applied. In addition, the bladder 12 may be cooled to stiffen and stabilize the material of the bladder to further ease winding of the reinforcing layer.

[0017] The cover 16 forms the exterior surface of the ball. The cover 16 in the present invention is formed of a urethane

gum rubber composition which is molded in place over the monofilament wrapped bladder and cured, preferably in a spherical mold with the application of heat and pressure to promote the cure and cross-linking of the urethane cover material.

[0018] In FIG. 2 a second embodiment of the invention is shown with the ball 20 featuring a bladder 12 covered by a layer of windings 14, over which a multiple layer cover 22 is formed. The multiple layer cover 22 features an inner or first layer 24 which surrounds and encloses the bladder 12 and wound layer 14, and an outer or second cover layer 26 which surrounds and encloses the first cover layer 24 and defines the ball exterior surface 18. The first cover layer 24 is formed of a natural rubbers while the outer cover layer 26 is formed of a urethane gum rubber composition.

[0019] In FIG. 3 a basketball with a multiple layer cover is shown partially cut away. The ball 30 includes a bladder 12 covered with a layer of windings 14 which is enclosed by an inner cover layer 24 of a natural rubber composition, the whole being enclosed and enveloped within an outer cover layer 26 of urethane gum rubber.

[0020] The use of a multiple layer cover combining a layer of natural rubber with a layer of urethane gum rubber in the cover reduces the total amount of urethane gum rubber required in a ball of the present invention. At present market prices, urethane gum rubber materials are quite expensive. Creating a cover with a reduced amount of urethane gum rubber is of particular interest in controlling the cost of a game ball. By reducing the thickness of the urethane gum rubber used in the cover of the ball and adding a layer of natural rubber, the desirable durability and long-wearing properties are retained while the total expense of the materials from which the ball is made are reduced. The urethane gum rubber used in the cover of the invention is a raw rubber material based on polyurethane which can be processed using conventional machinery intended for processing natural rubber compounds. Like a natural rubber composition, the urethane gum rubber is shaped and then subjected to a cross-linking process (vulcanization).

[0021] The cover of the ball of the present invention may be molded to include a textured outer surface 18 for improving the grip and feel of the ball. It will be appreciated that the surface 18 of a basketball can be molded with a surface texture simulating the pebbled texture of pebble-grained leather or any other texture as desired. Other surface detail including the manufacturer's name, trademarks, model numbers, inflation instructions, ball detailing such as simulated lacing or stitching, and graphics can also be molded into the surface of the ball.

[0022] In terms of physical properties, once a urethane gum rubber is cross-linked and cured it exhibits high tear resistance, high elongation at break, high rebound resilience, and depending on the composition, a Shore A hardness of about 45-85. The cross-linked urethane gum rubber also has excellent resistance to degradation from exposure to ultra-violet light, oxygen, and ozone. What is of greatest interest in the present invention is the high degree of abrasion resistance offered by the urethane gum rubber.

[0023] One particular urethane gum rubber highly suitable for use in this invention is commercially available from Rhein Chemie Corporation, Trenton, N.J., and is commercially available as UREPAN 50EL06G. This particular urethane material is the poly-addition product made from diphenylmethane diisocyanate and a C₄ polyether. According to the

manufacturer, UREPAN 50EL06G may be processed using standard rubber industry processing techniques and equipment without any restrictions. It will be appreciated by the practitioner of skill in the art that other UREPAN materials and similar materials available from other chemical manufacturers, may be selected according to their physical properties for the desired game ball application. The urethane gum rubber of the present invention is mixed with other materials for processing into a game ball cover. In general, these materials include vulcanizing agents for promoting the cross-linking of the urethane gum rubber and various other components including fillers, coloring materials, and materials to improve processing.

[0024] The vulcanizing agents act as cross-linking agents and as cure accelerators. The use of sulfur plus mercapto accelerators has proven to be favorable for use as vulcanizing agents in urethane gum rubber resin compositions. Zinc stearate may be used as a coactivator. Therefore, combinations of sulfur, mercaptobenzothiazole (MBT), dibenzothiazyl disulphide (MBTS), complexes of zinc chloride and dibenzothiazyl disulphide (RHENOCURE AUR available from Rhein Chemie Corp., Trenton, N.J.) and mixtures thereof may be used as cross-linking agents and cure accelerators in urethane gum rubber resin compositions.

[0025] A general formula setting forth the amounts of various components and additives suitable for making a game ball cover is presented in Table 1 below.

TABLE 1

URETHANE GUM RUBBER COMPOSITION	
General Formula	
Ingredient	Parts by Weight
urethane	50-100
sulfur	1-4
reinforcing filler	5-50
zinc stearate	0.25-2.0
curing agent	0.5-2.0
cure accelerator(s)	1.0-6.0
coloring pigment(s)	0-5
processing promoter	1.0-5.0
dispersing and tackifying resin	0.5-3.0

[0026] The process of manufacturing a game ball of the present invention is generally similar to that used in manufacturing a game ball having a natural rubber cover. In the case of a game ball having a cover 16 comprising a single layer of urethane gum rubber, a bladder 12 of butyl rubber is manufactured by conventional methods, such as by parison blow-molding or by blow-molding two parallel sheets of uncured butyl rubber in a spherical mold. Typically, a valve is molded into the bladder 12 when the bladder is formed.

[0027] The bladder 12 is inflated to an appropriate pressure to stabilize its spherical shape and monofilaments of polyester and/or nylon are then wrapped around the bladder 12 to create the winding layer 14. To cause the windings to adhere to the bladder and to each other, and thus simplify the winding process, the filaments are lightly coated with an adhesive (not shown) compatible with the materials of the bladder 12, the windings, and the cover 16. As the monofilaments are wrapped in place around the bladder 12 the adhesive holds them in place and prevents them from unraveling.

[0028] A batch of urethane gum rubber is prepared having a general composition as set forth in Table 1. The components of the composition are mixed using standard rubber process-

ing equipment, such as a Banbury mixer, to thoroughly combine the ingredients. A pliable, moldable dough-like mass is produced which can subsequently be molded and cured. For the cover of a ball, such as a basketball, the dough-like mass of uncured urethane gum rubber is formed into a sheet such as by passing it through the rollers of a calendaring machine. The uncured sheet is cut to an appropriate size and shape for lining the interior surface of a hemispherical ball mold. For a basketball, the sheet can be cut into double-tapered panels or simple strips, for example, and laid in each half of the ball mold to completely cover the mold surface. A mold may feature a vacuum system to hold the panels in place in the mold or, alternately, a light adhesive may be used to hold the panels in place. Typically, the panels or pieces of uncured sheet of urethane gum rubber are overlapped at their edges to ensure the structural integrity of the molded cover. Alternatively, the urethane gum rubber can be preformed into a hollow hemispherical shape ending at an equator line. Two urethane hemispheres are then placed in opposition within the mold with their equator lines facing.

[0029] The interior surface of the ball mold may be engraved or tooled to impart a surface texture to the cover of the finished ball. Also, simulated stitching, lacing, seams or panel lines may be added to the mold surface, along with manufacturers' names, model names and numbers, autographs of sport figures and graphic designs, for molding into the ball cover.

[0030] A bladder **12** and winding layer **14** subunit is placed into the mold lined with urethane cover material and the mold is closed around the subunit. The bladder is inflated to force the subunit into full contact with the urethane material lining the interior of the mold cavity. Heat and pressure is applied to the mold to cause the raw urethane gum rubber to flow into and around the monofilaments of the winding layer and to assume the shape and texture imparted by the tooled mold inner surface. The heat and pressure also causes the urethane material to cross-link and cure, firmly bonding the cover and subunit into a unitary basketball and permanently creating the textured exterior surface of the ball. At the end of the time necessary to attain the desired level of cross-linking, the completed ball is removed from the mold and allowed to cool. Any flash or mold marks left on the cover of the finished ball may be buffed out or otherwise removed. The ball may then be decorated through the application of paint, decals, and other graphics or decorations.

[0031] The game ball **20** of the present invention which possesses a multi-layer cover **22** may be made according to a process similar to that described above. A layer of raw urethane gum rubber sheet is placed in contact with the mold halves. A layer of raw natural rubber sheet is placed in contact with the urethane gum rubber layer. The bladder and winding layer subunit is placed within the mold, the mold is closed and the bladder inflated. Heat and pressure is applied and both the natural rubber and urethane gum rubber flow and are cured within the mold. Naturally, one or both of the natural and urethane rubber layers could also be in the form of hollow hemispheres which are layered in opposition within the mold.

[0032] The ball of the invention may also be manufactured using the carcass and panel method as described in U.S. Pat. No. 3,119,618. This method is particularly suited for the manufacture of basketballs. Following this method a ball carcass which encapsulates the bladder and windings can be molded from a natural rubber compound. The carcass is formed with protruding channels which provide assistance in

locating the cover panels in position on the ball. The cover panels are formed from a urethane gum rubber composition and cured in a mold which provides cover panels of the exact size and shape need to fit between the channels of the carcass. The cured panels are glued in place on the carcass with an adhesive appropriate for the carcass and cover materials, the ball is given a final clean-up to remove manufacturing marks, and detail or decoration are added, as needed.

[0033] When a multi-layered cover is to be made special care must be taken in selecting and preparing the materials used in the cover and also special care must be taken in the subsequent cross-linking process. It is well known that natural rubber cross-links at a much faster rate than the urethane gum rubber. For example, a typical natural gum rubber composition will typically vulcanize within 5 minutes upon application of 150° C. In contrast, a urethane gum rubber as used in the present invention may take up to 15 minutes to achieve a desired level of cross-linking. It is further known that exposing the natural rubber to the amount of heat necessary to achieve proper cross-linking for the urethane gum rubber may damage the natural rubber. Conversely, exposing the urethane gum rubber to the amount of heat necessary to cause cross-linking of the natural rubber will leave the urethane gum rubber under cured. To accommodate the disparate cure rates of the natural rubber and the urethane gum rubber the inventors have found that reduced amounts of accelerators in the natural rubber composition may be used.

[0034] It may be desirable for certain game ball applications to produce a softer cover material. As the urethane gum rubber of the cover is typically rather hard, the inventors have found that foaming the natural rubber layer of the multi-layered cover provides the finished ball with an appropriate level of cover softness. In the case of a basketball cover, a foam rubber density in the range of 0.5 to 0.95 grams/cubic centimeter (g/cm³) provides a ball with good feel and playability.

[0035] In a game ball with a single layer cover, the thickness of the urethane gum rubber layer ranges from 0.3 to 3.5 mm, more preferably from 0.9 to 2.7 mm and optimally is about 1.9 mm. In a game ball with a multiple layer cover, the thickness of the inner natural rubber layer ranges from 0.1 to 1.6 mm, more preferably from 0.6 to 1.4 mm and is optimally about 1.1 mm. The outer urethane gum rubber layer overlying the inner natural rubber layer ranges from 0.3 to 1.9 mm, more preferably from 0.5 to 1.4 mm and is optimally about 0.8 mm. Naturally, when a carcass with protruding channels is used, the thickness of the inner natural rubber layer will be greater in the area of the channels.

[0036] A batch of urethane gum rubber was prepared according to the formulation found in Table 2 below. This composition is identified as STOCK EXAMPLE 1 (Stock Ex. 1).

TABLE 2

STOCK EXAMPLE 1 - URETHANE GUM RUBBER COMPOSITION	
Ingredient	Parts by Weight
UREPAN 50ELO6G ¹ urethane rubber resin	100.00
sulfur	1.50
CABOSIL ² reinforcing filler	40.00
zinc stearate	0.50
RHENOCURE AUR ³ curing agent	1.00
ALTAX (MBTS) ⁴ cure accelerator	4.00

TABLE 2-continued

STOCK EXAMPLE 1 - URETHANE GUM RUBBER COMPOSITION	
Ingredient	Parts by Weight
CAPTAX (MBT) ⁵ cure accelerator	2.00
ORANGE MASTER BATCH ⁶ coloring	3.50
TiO ₂ coloring pigment	2.00
AFLUX 12 ⁷ processing promoter	1.00
RHENOSIN TM90 ⁸ processing promoter	4.00
TOTAL	159.5

¹UREPAN 50ELO6G is a urethane rubber resin commercially available from Rhein Chemie Corp., Trenton, New Jersey.

²CABOSIL is a fumed silica reinforcing filler commercially available from Cabot Corp., Atlanta, Georgia.

³RHENOURE AUR is a curing agent for sulphur cross-linkable polyurethane rubbers and is commercially available from Rhein Chemie Corp., Trenton, New Jersey.

⁴ALTAX is an MBTS cure accelerator commercially available from R. T. Vanderbilt, Norwalk, Connecticut.

⁵CAPTAX is an MBT cure accelerator commercially available from R. T. Vanderbilt, Norwalk, Connecticut.

⁶ORANGE MASTER BATCH is an orange colored pigment master batch commercially available from Disco Inc., Ringwood, New Jersey.

⁷AFLUX 12 is a processing promoter for synthetic rubber compounds and is commercially available from Rhein Chemie Corp.

⁸RHENOSIN TM90 is a processing promoter which improves the distribution of fillers within the rubber composition and is commercially available from Rhein Chemie Corp.

[0037] The ingredients were mixed in a Banbury-type mixer to completely mix the ingredients and obtain a batch of stock identified as Stock Example 1. It will be appreciated that the urethane gum rubber of the invention may be mixed and processed using conventional rubber making equipment and techniques. The uncured mixture was then passed through a calendaring machine or a 2 roll mill to produce a sheet of uncured urethane gum rubber. The sheet was cut into several pieces each sized to fit a plaque mold and the pieces were cured in an electric press under various conditions which are outlined below. The samples were tested to determine their physical properties.

STOCK EX. 1-A

[0038] A sample Stock Example 1 was placed in a mold preheated and maintained at a temperature of 150° C. The material remained in the hot mold for 10 minutes under 7 tons of pressure to form a plaque and was removed while hot. This plaque was tested and found to have a Shore A hardness of 77.

STOCK EX. 1-B

[0039] A plaque was prepared as in Example-1A above, with the plaque remaining in the hot mold for 20 minutes. This plaque was tested and found to have a Shore A hardness of 77.

STOCK EX. 1-C

[0040] A plaque was prepared as in Example 1-A above, with the plaque remaining in the hot mold for 30 minutes. This plaque was tested and found to have a Shore A hardness of 78.

COMPARATIVE EXAMPLE 1

[0041] A batch of natural rubber cover stock having a composition as set forth in Table 3 below was also prepared. This composition is identified as COMPARATIVE EXAMPLE 1 (Comp. Ex. 1).

TABLE 3

COMPARATIVE EXAMPLE 1 - NATURAL RUBBER COMPOSITION	
Ingredient	Parts by Weight
60 CV ¹ Malaysian natural rubber resin	59.00
ANDREZ 8000 ² high styrene resin	22.00
CARIFLEX BR-1220 ³ polybutadiene	19.00
VERFLAKE (CaCO ₃) ⁴ filler	60.00
HISIL 233 ⁵ reinforcing filler	18.50
CIRCO ⁶ light oil processing oil	5.00
ZnO activator	3.30
stearic acid activator	2.00
DEG diethylene glycol activator	1.00
CUMAR ⁷ resin plasticizer	2.20
VANAX 1290 ⁸ antioxidant	2.20
ORANGE MASTER BATCH coloring pigment	3.50
sulfur	1.90
CAPTAX (MBT) cure accelerator	.78
ALTAX (MBTS) cure accelerator	.24
unads ⁹ cure accelerator	.50
m. tuads ¹⁰ vulcanization accelerator	1.00
Total	202.12

¹SMR 60 CV is a natural butyl resin obtained from Malaysian rubber trees and is commercially available from Muehlstein, Leominster, Massachusetts.

²ANDREZ 8000 is a commercially available from high styrene/butadiene resin commercially available from Anderson Development, Adrian, Michigan.

³CARIFLEX B2-1220 is a polybutadiene commercially available from Muehlstein, Norwalk, Connecticut

⁴VERFLAKE is a calcium carbonate filler commercially available from Hampden Color & Chemical, Springfield, Massachusetts.

⁵HISIL 233 is a fumed silica reinforcing filler commercially available from PPG Industries, Pittsburgh, Pennsylvania

⁶CIRCO light oil is a processing oil commercially available from Sun Chemical, Cincinnati, Ohio.

⁷CUMAR is a plasticizer/softener commercially available from Neville Chemical, Pittsburgh, Pennsylvania.

⁸VANAX 1290 antioxidant commercially available from R. T. Vanderbilt.

⁹unads is a tetramethyl thiuram monosulfide vulcanization accelerator commercially available from R. T. Vanderbilt, Norwalk, Connecticut.

¹⁰m. tuads is a methyl tetramethyl thiuram disulfide vulcanization accelerator commercially available from R. T. Vanderbilt, Norwalk, Connecticut.

[0042] The natural rubber composition was mixed in a Banbury mixer, formed into a sheet on a 2 roll mill and pieces of the sheet were cut to fit a plaque mold. The pieces were then cured in an electric press under various conditions as outlined below. Tests were conducted to determine their physical properties.

COMP. EX. 1-A

[0043] A sample of the batch of stock identified as Comp. Ex. 1 was placed in a mold preheated and maintained at a temperature of 140° C. The material remained in the hot mold for 10 minutes to form a plaque and then was removed while hot. This plaque was tested and found to have a Shore A hardness of 70.

COMP. EX. 1-B

[0044] A plaque was prepared as in Comp. Ex. 1-A above, with the plaque remaining in the hot mold for 20 minutes. This plaque was tested and found to have a Shore A hardness of 77.

COMP. EX. 1-C

[0045] A plaque was prepared as in Comp. Ex. 1-A above, with the plaque remaining in the hot mold for 30 minutes. This plaque was tested and found to have a Shore A hardness of 78.

[0046] Comparative testing was carried out on samples of the urethane gum rubber and the natural rubber of the control stock using a Taber abrasion testing machine following the methods outlined in ASTM F 510-78. The results of the Taber abrasion test are reported below in Table 4.

TABLE 4

ABRASION TESTING (TABER)		
Material	Mass in grams of amount abraded after 1000 cycles using H-18 "GREY WHEEL"	
	1 st RUN	2 nd RUN
Comp. Ex. 1-A, natural rubber, 10 min. cure time	0.84	1.03
Stock Ex. 1-A, urethane gum rubber, 10 min. cure time	0.11	0.12
Comp. Ex. 1-B, natural rubber, 20 min. cure time	1.08	1.04
Stock Ex. 1-B, urethane gum rubber, 20 min. cure time	0.11	0.10
Comp. Ex. 1-C, natural rubber, 30 min. cure time	1.11	1.08
Stock Ex. 1-C, urethane gum rubber, 30 min. cure time	0.11	0.10

[0047] In each of the abrasion test runs it was found that the polyurethane rubber provided substantially greater resistance

according to the present invention was designated Example 2. In the bounce test each ball was propelled from a series of rotating wheels (in a manner similar to batting practice machines used to pitch baseballs) at an angled barrier comprising a new, cross-hatched steel bounce plate. The ball bounces off the angled barrier and is directed into a net where the energy of the rebounding ball is dissipated. A return ramp in the mechanism automatically returns the ball to the wheels for repeated firing against the angled barrier. The firing is continued until the ball has been fired against the barrier 10,000 times; each impact with the angled barrier being counted as a single bounce.

[0049] Prior to the testing each ball was measured to determine the initial circumference (size) of the ball in inches, initial weight in grams, durometer hardness (using a Type "O" gauge from Rex Gauge Company, 1250 Busch Parkway, Buffalo Grove, Ill.), and out of round measurement or "O/R". Out of round measurement is tested by placing a ball on a roller stand. A dial indicator is placed against the ball outside surface and the gauge is set to read zero. The ball is rotated on the roller stand 360 degrees and the high and low readings on the gauge are recorded. The ball is repositioned a total of three times and the high and low measurements are averaged. The differences between the high and low readings represent the out of round measurement.

[0050] After 10,000 bounces the size, weight, durometer hardness and O/R measurements were taken again. In addition, the change in weight of each ball was determined. The data accumulated is reported in Table 5, below.

TABLE 5

BOUNCE AND ABRASION TESTING OF BASKETBALLS										
		Measurements After 10,000 Bounces								
Mfg.	Ball Model	Initial Measurements								Change in Wt.
		Dur.	Size	O/R	Wt.	Dur.	Size	O/R	Wt.	
	Example 2	72	30.13	0.087	596.9	72	30.31	0.125	593.7	3.2
Wilson	Jet Extreme	56	29.88	0.116	598.3	54	30	0.160	594.5	3.8
Vega	NBA Ultimate	70	29.63	0.077	593.5	67	29.75	0.116	578.7	14.8
Rawlings	RR1	73	29.63	0.028	615.2	70	30.00	0.109	598.6	16.6
Urax	ZR Cushion	58	29.75	0.049	596.2	55	30.06	0.182	578.8	17.4
Urax	Kobe	71	29.75	0.046	595.1	67	30.00	0.187	573.3	21.8
Nike	NSB 1000	70	29.56	0.050	621.6	70	29.63	0.085	586.4	35.2

Weight Measurements (wt.) are given in grams.

Size refers to the circumference of the ball measured in inches.

to abrasion than did natural rubber. It will be recalled that natural rubber cures more quickly than urethane rubber and consequently one might expect natural rubber to have greater abrasion resistance than urethane rubber at the shorter cure times. Surprisingly, the urethane rubber exhibits higher abrasion resistance than natural rubber at every cure time tested. It is also projected that the urethane rubber likewise would perform superior to the natural rubber at every cross-link density. It will be appreciated that improved abrasion resistance translates directly into longer ball life and retention of molded surface texture.

[0048] A ball made according to the present invention with a polyurethane rubber cover was tested against several commercially available balls in a bounce test. The ball made

[0051] As shown in Table 5, the ball made according to the present invention, Example 2, showed the lowest change in weight due to abrasion incurred in the bounce test. The durometer hardness remained unchanged before and after the test, a performance which was only equaled by the Nike "NSB 1000" ball. The Example 2 ball showed a slight increase in size (0.18 inch) due to the repeated impacts. This is well within acceptable limits and less than the Urax "ZR Cushion" and Urax "Kobe" balls.

[0052] As will be apparent to those skilled in the art, various modifications and adaptations will become readily apparent without departure from the spirit and scope of the invention.

1. A game ball comprising:
 - an inflatable bladder;
 - a layer of windings disposed about said bladder; and

a cover disposed about said layer of windings, said cover including a vulcanized urethane gum rubber layer, said urethane gum rubber layer having a thickness of from 0.3 mm to 3.5 mm.

2. (canceled)
3. (canceled)
4. (canceled)
5. (canceled)
6. (canceled)
7. (canceled)
8. (canceled)
9. (canceled)
10. (canceled)
11. (canceled)
12. (canceled)
13. (canceled)
14. (canceled)
15. (canceled)
16. (canceled)
17. (canceled)
18. (canceled)
19. (canceled)
20. (canceled)
21. (canceled)
22. (canceled)

23. The game ball of claim 1, wherein the thickness of said urethane gum rubber layer is from 0.9 mm to 2.7 mm.

24. The game ball of claim 1, wherein said urethane gum rubber layer comprises a urethane gum rubber obtained from the poly-addition of an isocyanate and a polyether; and said urethane gum rubber is vulcanized through a sulfur-based cross-linking reaction.

25. The game ball of claim 1, wherein said urethane gum rubber layer comprises a urethane gum rubber obtained from the poly-addition of a diphenylmethane diisocyanate and a C₄ polyether; and said urethane gum rubber is vulcanized through a sulfur-based cross-linking reaction.

26. The game ball of claim 1, wherein said cover further comprises a vulcanization agent selected from the group consisting of sulfur, mercaptobenzothiazole, dibenzothiazyl disulphide, zinc chloride complex of dibenzothiazyl disulphide and mixtures thereof.

27. The game ball of claim 5, wherein said cover has a composition comprising 50 to 100 parts of a urethane gum rubber and 2.5 to 12.0 parts of said vulcanization agent expressed parts by weight based on 100 parts urethane.

28. The game ball of claim 6, wherein said composition further comprises 5 to 50 parts of a reinforcing filler.

29. The game ball of claim 1, wherein said cover further includes an inner layer overlaid by said urethane gum rubber layer.

30. The game ball of claim 8, wherein said inner layer is comprised of cured natural rubber.

31. The game ball of claim 9, wherein said inner layer is foamed and has a density within the range of 0.5 to 0.95 g/cm³.

32. The game ball of claim 8, wherein the thickness of said urethane gum rubber layer is from 0.3 mm to 1.9 mm.

33. The game ball of claim 11, wherein the thickness of said urethane gum rubber layer is from 0.5 mm to 1.4 mm.

34. The game ball of claim 11, wherein the thickness of said inner layer is from 0.1 mm to 1.6 mm.

35. The game ball of claim 1, wherein said urethane gum rubber layer has a Shore A durometer hardness within the range of 45 to 85.

36. A game ball comprising:

an inflatable bladder;

a layer of polymeric filaments wound over said bladder; and

a cover molded over said layer of filaments, said cover comprising a vulcanized urethane gum rubber layer, wherein said urethane gum rubber comprises a urethane gum rubber obtained from the poly-addition of an isocyanate and a polyether; and said urethane gum rubber is vulcanized through a sulfur-based cross-linking reaction.

37. The game ball of claim 15, wherein said cover consists essentially of said urethane gum rubber layer.

38. The game ball of claim 15, wherein said cover further comprises a vulcanized natural rubber layer, said natural rubber layer positioned between said layer of filaments and said vulcanized urethane gum rubber layer.

39. The game ball of claim 17, wherein said cover consists essentially of said urethane gum rubber layer overlying said natural rubber layer.

40. The game ball of claim 17, wherein said inner layer of said cover is foamed to attain a density of 0.5 to 0.95 g/cm³.

41. The game ball of claim 17, wherein said inner layer has a thickness in the range of 0.01-1.16 mm and said urethane gum rubber layer has a thickness in the range of 0.3-1.9 mm.

42. A basketball comprising:

an inflatable bladder;

a layer of polymeric filaments overlaying said bladder; and a multi-layered cover overlying said layer of filaments, said cover comprising a vulcanized natural rubber inner layer with a density of at least 0.8 g/cm³ overlying said layer of filaments and a vulcanized urethane rubber exterior layer with a density of at least 0.8 g/cm³ overlying said inner layer, said exterior layer having a higher durometer hardness and greater abrasion resistance than said inner layer.

43. The basketball of claim 21, wherein the thickness of said exterior layer is from 0.3 mm to 1.9 mm.

44. The basketball of claim 22, wherein the thickness of said exterior layer is from 0.5 mm to 1.4 mm.

45. The basketball of claim 21, wherein the thickness of said inner layer is from 0.1 mm to 1.6 mm.

46. The basketball of claim 24, wherein the thickness of said inner layer is from 0.6 mm to 1.4 mm.

47. A method for making a game ball, comprising:

providing a core;

providing urethane gum rubber resin obtained from the poly-addition of an isocyanate and a polyether;

mixing a vulcanized agent with said urethane gum rubber resin to create a urethane gum rubber;

molding said urethane gum rubber over said core; and

vulcanizing said urethane gum rubber through a sulfur-based cross-linking reaction.

48. The method of claim 26, wherein said urethane gum rubber resin is obtained from the poly-addition of a diphenylmethane diisocyanate and a C₄ polyether.

49. The method of claim 26, wherein said vulcanization agent is selected from the group consisting of sulfur, mercaptobenzothiazole, dibenzothiazyl disulphide, zinc chloride complex of dibenzothiazyl disulphide and mixtures thereof.

50. The method of claim **26**, further comprising the step of molding a rubber inner layer over said core and wherein the step of molding said urethane gum rubber over said core comprises molding said urethane gum rubber over said rubber inner layer.

51. The method of claim **29**, wherein said step of molding a rubber inner layer over said core comprises foaming said inner layer to a density within the range of 0.5-0.95 g/cm³.

* * * * *