



(12) **United States Design Patent**
Pojanaporn

(10) **Patent No.:** **US D1,004,117 S**
(45) **Date of Patent:** **** Nov. 7, 2023**

(54) **PERCUSSION MASSAGER**

FOREIGN PATENT DOCUMENTS

(71) Applicant: **MerchSource, LLC**, Irvine, CA (US)

WO 2021222571 A1 11/2021

(72) Inventor: **Wantana Pojanaporn**, Anaheim, CA (US)

OTHER PUBLICATIONS

(73) Assignee: **MerchSource, LLC**, Irvine, CA (US)

Amazon, "Sharper Image Powerboost_Massage Gun", Date First Available: Apr. 2, 2021. <https://www.amazon.com/SHARPER-IMAGE-Deep-Tissue-Professional-Attachments/dp/B091JF576T> (Year: 2021).*

(**) Term: **15 Years**

Primary Examiner — Michael A Maharajh

(21) Appl. No.: **29/806,032**

(74) *Attorney, Agent, or Firm* — Avyno Law P.C

(22) Filed: **Aug. 31, 2021**

(51) **LOC (14) Cl.** **24-01**

(52) **U.S. Cl.**
USPC **D24/215**

(58) **Field of Classification Search**
USPC D24/200, 211, 212, 213, 214, 215;
D8/14.1; D28/13
CPC A61H 23/006; A61H 2201/0153; A61H
7/005; A61H 23/00; A61H 7/003
See application file for complete search history.

(57) **CLAIM**

I claim the ornamental design for a percussion massager, as shown and described.

(56) **References Cited**

U.S. PATENT DOCUMENTS

898,209	A	9/1908	Foster
925,758	A	6/1909	Davis
D403,075	S	12/1998	Lie
D407,498	S	3/1999	Cooper
D478,385	S	8/2003	Dirks et al.
D531,733	S	11/2006	Burout, III et al.
D609,817	S	2/2010	Piller et al.
D659,843	S	5/2012	Wang
D693,932	S	11/2013	Nichols
9,889,066	B2	2/2018	Danby et al.
10,305,627	B2	5/2019	Li et al.
10,314,762	B1	6/2019	Marton et al.
10,357,425	B2	7/2019	Wersland et al.
D855,822	S	8/2019	Marton et al.
10,428,850	B2	10/2019	Wersland et al.
10,470,970	B2	11/2019	Nazarian et al.
10,492,984	B2	12/2019	Marton et al.
D873,432	S	1/2020	Duan

(Continued)

DESCRIPTION

FIG. 1 is a top perspective view of the front and left side of a percussion massager of the present invention.
FIG. 2 is a bottom perspective view the rear and right side of the percussion massager of FIG. 1.
FIG. 3 is a side elevation view of the left side of the percussion massager of FIG. 1.
FIG. 4 is a side elevation view of the right side of the percussion massager of FIG. 1.
FIG. 5 is a front elevation view of the percussion massager of FIG. 1.
FIG. 6 is a rear elevation view of the percussion massager of FIG. 1.
FIG. 7 is a top plan view of the percussion massager of FIG. 1; and,
FIG. 8 is a bottom plan view of the percussion massager of FIG. 1.
In the drawings, the broken lines depict portions of the percussion massager that form no part of the claimed design.

1 Claim, 6 Drawing Sheets

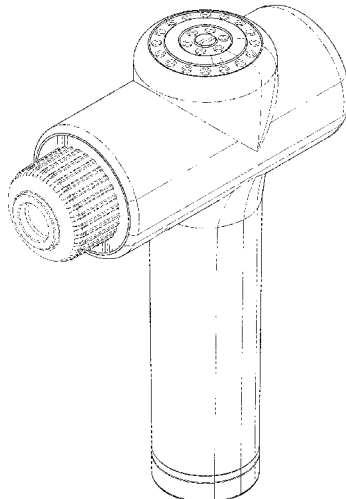

(56)

References Cited

U.S. PATENT DOCUMENTS

D874,015	S	1/2020	Marton et al.	11,160,721	B2	11/2021	Wersland et al.
D875,961	S	2/2020	Li	11,160,722	B2	11/2021	Wersland et al.
10,557,490	B2	2/2020	Wersland et al.	11,160,723	B2	11/2021	Wersland et al.
10,561,574	B1	2/2020	Marton et al.	11,166,863	B2	11/2021	Wersland et al.
10,617,588	B2	4/2020	Wersland et al.	D938,056	S	12/2021	Wu
D884,205	S	5/2020	Zhuang	D939,101	S	12/2021	Yang
D884,207	S	5/2020	Ma	D939,103	S	12/2021	Xu
D886,317	S	6/2020	Marton et al.	D939,724	S	* 12/2021	Hu D24/215
10,682,281	B2	6/2020	Smith, Jr. et al.	D939,725	S	12/2021	Tong
10,702,448	B2	7/2020	Wersland et al.	D940,345	S	1/2022	Cheng
10,714,953	B1	7/2020	Solana et al.	D940,892	S	* 1/2022	Shen D24/215
D893,738	S	8/2020	Zhuang	11,253,423	B1	2/2022	Williams et al.
D895,132	S	9/2020	Hu	D945,007	S	* 3/2022	Liu D24/215
D895,133	S	9/2020	Xu	D946,779	S	3/2022	Ren
D895,135	S	* 9/2020	Xu D24/215	11,285,075	B2	3/2022	Danby et al.
D895,829	S	9/2020	Hu	D948,067	S	4/2022	Zheng et al.
D895,831	S	* 9/2020	Chen D24/215	D948,068	S	4/2022	Xu
10,758,452	B2	9/2020	Wersland et al.	D948,739	S	4/2022	Zou
10,774,860	B2	9/2020	Wersland et al.	D949,369	S	* 4/2022	Wu D24/211
D898,209	S	10/2020	Xu	D949,379	S	4/2022	Xu
D898,933	S	10/2020	Xu	D949,381	S	4/2022	Kong
10,847,984	B2	11/2020	Solana et al.	D949,383	S	4/2022	Xu
D905,863	S	12/2020	Lin	D949,384	S	4/2022	Liang
D906,533	S	12/2020	Xu	D949,385	S	4/2022	Zang
10,857,064	B2	12/2020	Wersland et al.	D949,389	S	4/2022	Ying
D907,229	S	* 1/2021	Zhang D24/215	D949,419	S	4/2022	Lin
D907,230	S	1/2021	Zhang	D949,421	S	4/2022	Luo
D908,908	S	1/2021	Xu	D949,427	S	4/2022	Ying
10,888,492	B2	1/2021	Marton et al.	D950,087	S	* 4/2022	Shu D24/215
D910,194	S	2/2021	Radtke	D950,088	S	4/2022	Tian
D911,535	S	2/2021	Yu	D950,753	S	5/2022	Zhang
10,905,627	B2	2/2021	Marton et al.	D952,174	S	5/2022	Shu
10,912,707	B2	2/2021	Wersland et al.	D952,175	S	5/2022	Zou
10,912,708	B2	2/2021	Marton et al.	D952,884	S	5/2022	Wang
10,918,565	B2	2/2021	Wersland et al.	D952,885	S	5/2022	Zou
D912,267	S	3/2021	Tang	D953,556	S	5/2022	Marton et al.
D913,516	S	3/2021	Zhang	D953,557	S	5/2022	Wu
D913,517	S	3/2021	Yu	D956,251	S	6/2022	Marton et al.
10,940,081	B2	3/2021	Nazarian et al.	D956,252	S	6/2022	Marton et al.
10,945,915	B2	3/2021	Wersland et al.	D956,253	S	6/2022	Marton et al.
10,959,908	B2	3/2021	Lee et al.	D956,254	S	6/2022	Marton et al.
10,959,911	B2	3/2021	Wersland et al.	D956,255	S	6/2022	Marton et al.
D916,307	S	4/2021	Xiong	D956,256	S	6/2022	Marton et al.
D917,060	S	* 4/2021	Hu D24/215	D956,257	S	6/2022	Marton et al.
10,980,704	B2	4/2021	Wersland et al.	D956,258	S	6/2022	Marton et al.
D918,408	S	* 5/2021	Huang D24/215	11,357,697	B2	6/2022	Wersland et al.
D920,531	S	5/2021	Xu	D956,989	S	7/2022	Ma
10,993,874	B1	5/2021	Marton et al.	D956,992	S	7/2022	Lin
D921,916	S	6/2021	Xu	D956,994	S	7/2022	Marzolf et al.
D921,917	S	6/2021	Xu	D958,392	S	* 7/2022	Meng D24/215
D923,187	S	6/2021	Ma et al.	D961,108	S	8/2022	Jin
D923,188	S	6/2021	Xu	D961,799	S	8/2022	Ying
D923,190	S	6/2021	Xu	D962,188	S	8/2022	Min et al.
D923,194	S	6/2021	Xu	D962,461	S	8/2022	Zhang
D924,422	S	7/2021	Huang	D962,462	S	8/2022	Ji
D925,751	S	7/2021	Wu	D963,185	S	9/2022	Kong
D925,756	S	7/2021	Xu	D963,188	S	9/2022	Pang
D925,758	S	7/2021	Xu	D964,584	S	* 9/2022	Wang D24/215
D926,335	S	7/2021	Zhang	D964,585	S	9/2022	Tang et al.
D926,338	S	7/2021	Xu	D965,164	S	9/2022	Luo
D927,714	S	8/2021	Li	D965,808	S	10/2022	Jiang et al.
D927,715	S	8/2021	Li	11,478,400	B1	10/2022	Marton et al.
D928,338	S	8/2021	Hu	D968,637	S	11/2022	Xie et al.
D929,601	S	8/2021	Lin	D969,335	S	11/2022	Zhang
11,090,222	B2	8/2021	Zhou	D970,030	S	* 11/2022	Zheng D24/215
D931,481	S	9/2021	Li	11,497,676	B2	11/2022	Liu et al.
D931,487	S	9/2021	Li	D972,159	S	* 12/2022	Yu D24/215
D932,039	S	9/2021	Yu	D979,086	S	2/2023	Marton et al.
D932,045	S	9/2021	Shen	2019/0247271	A1	8/2019	Lee et al.
D933,250	S	10/2021	Shen	2020/0261306	A1	8/2020	Pepe
D934,441	S	10/2021	Zhang	2020/0276079	A1	9/2020	Cheng
D934,442	S	10/2021	Xu	2020/0289365	A1	9/2020	Wersland et al.
D935,636	S	* 11/2021	Luo D24/215	2020/0352822	A1	11/2020	Marton et al.
D935,637	S	11/2021	Li	2020/0352823	A1	11/2020	Marton et al.
D937,431	S	11/2021	Li	2020/0357046	A1	11/2020	McGann
				2020/0390644	A1	12/2020	Yang
				2021/0022951	A1	1/2021	Hu
				2021/0022955	A1	1/2021	Wersland et al.
				2021/0032257	A1	2/2021	Coates et al.

(56)

References Cited

U.S. PATENT DOCUMENTS

2021/0038472	A1	2/2021	Marton et al.
2021/0077340	A1	3/2021	Pepe
2021/0104318	A1	4/2021	Wersland et al.
2021/0113427	A1	4/2021	Liu et al.
2021/0161759	A1	6/2021	Minkus
2021/0169733	A1	6/2021	Wersland et al.
2021/0177692	A1	6/2021	Nazarian et al.
2021/0244609	A1	8/2021	Lee et al.
2021/0244610	A1	8/2021	Wersland et al.
2021/0244611	A1	8/2021	Wersland et al.
2021/0283005	A1	9/2021	Lee et al.
2021/0307998	A1	10/2021	Rochel
2021/0361524	A1	11/2021	Marton et al.
2022/0031554	A1	2/2022	Hu et al.
2022/0051780	A1	2/2022	Jacobs et al.
2022/0133585	A1	5/2022	Marton et al.

* cited by examiner

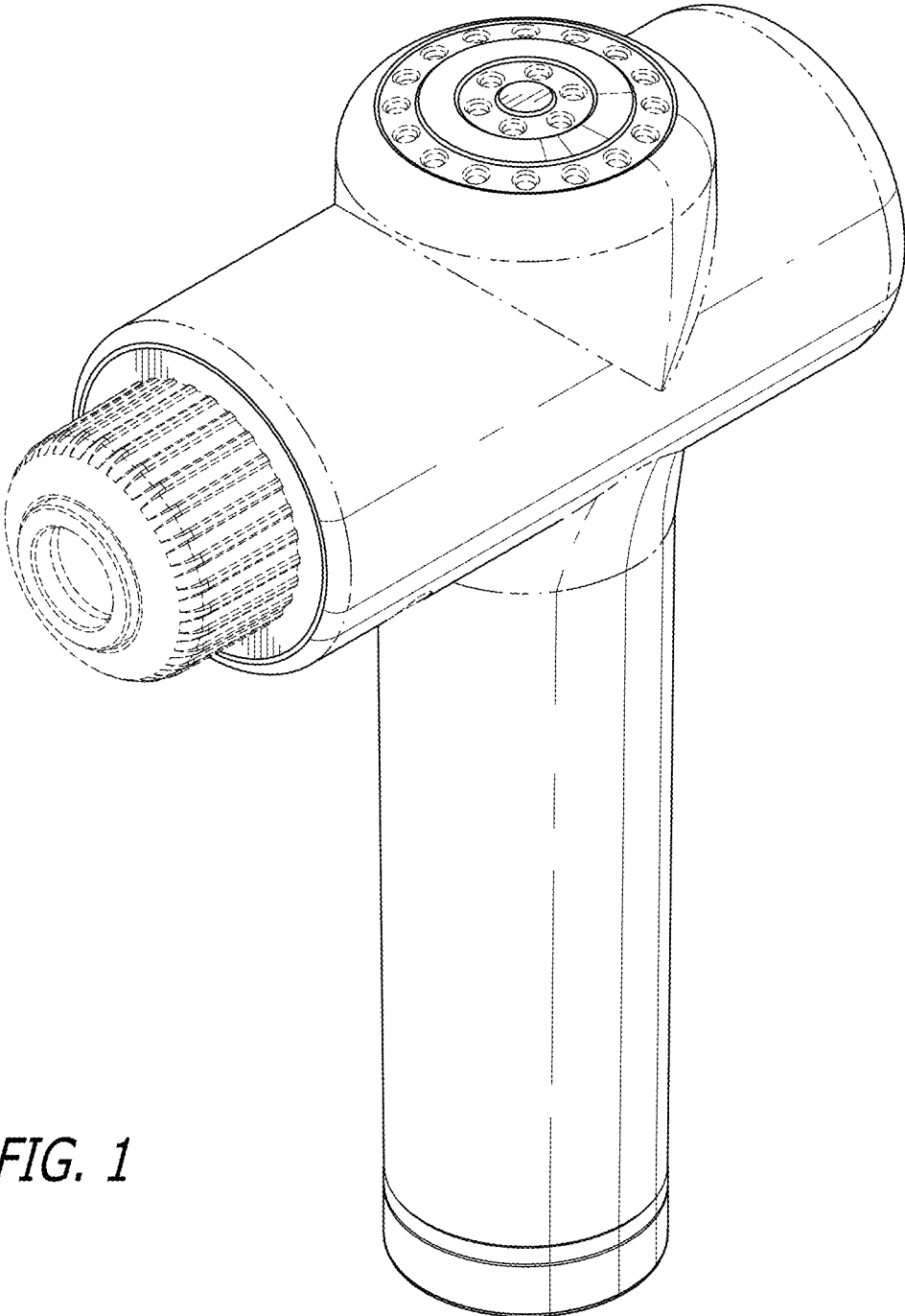

FIG. 1

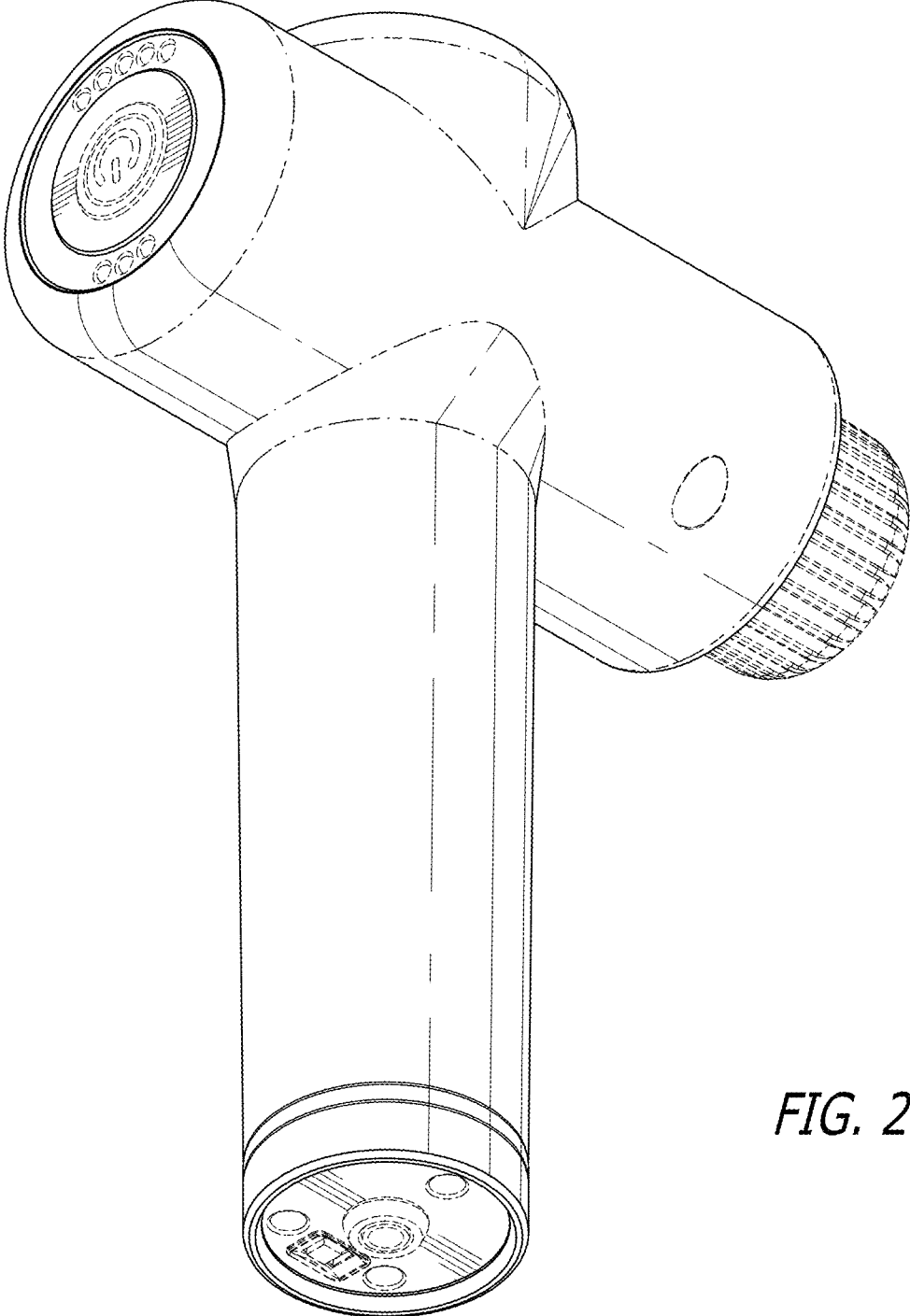

FIG. 2

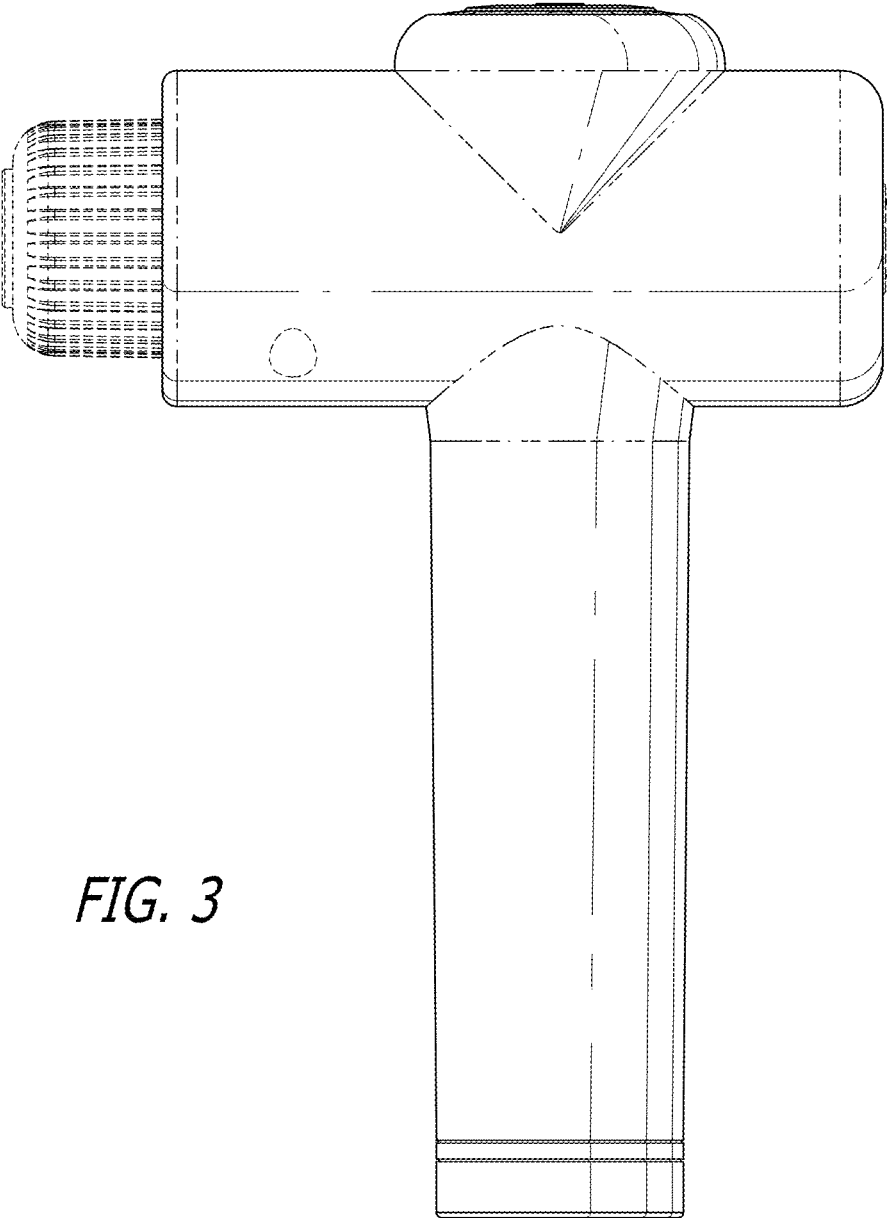

FIG. 3

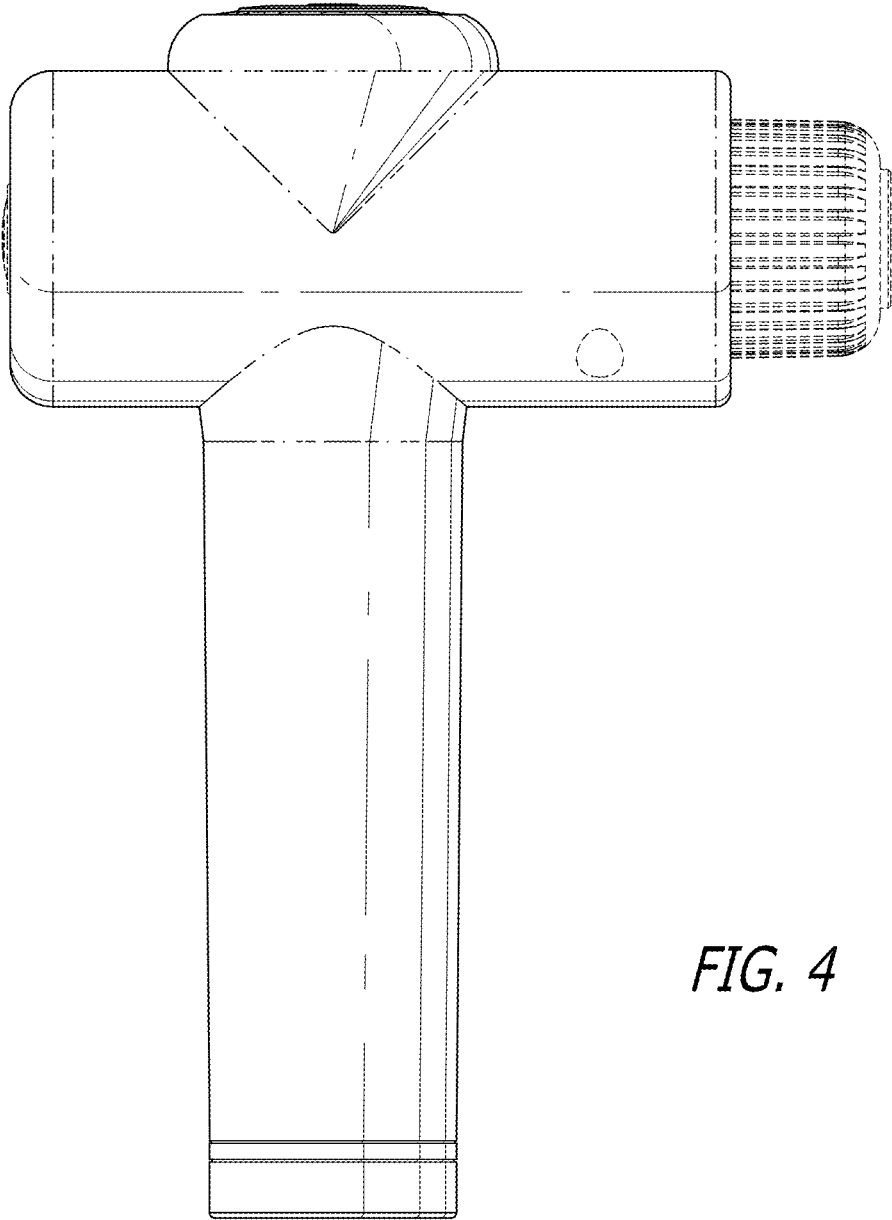

FIG. 4

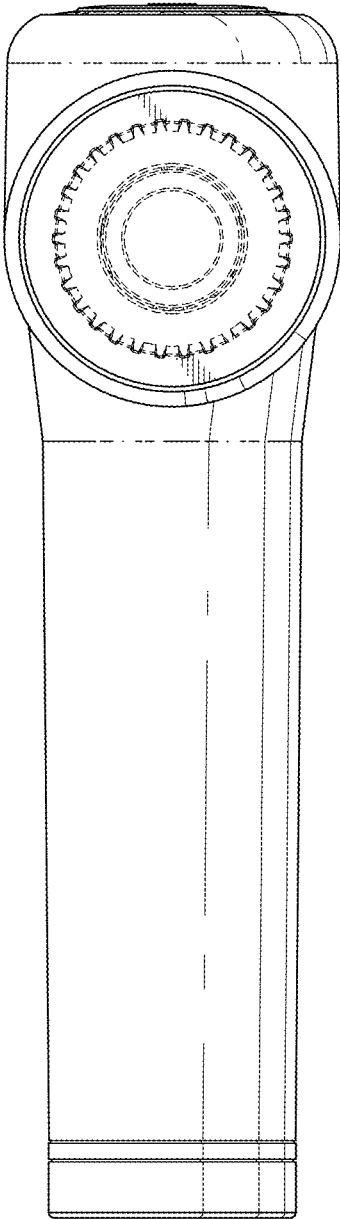

FIG. 5

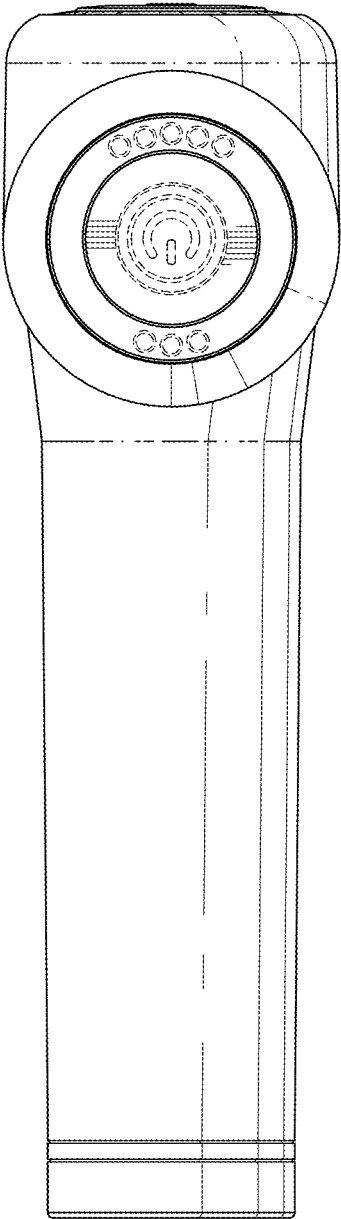

FIG. 6

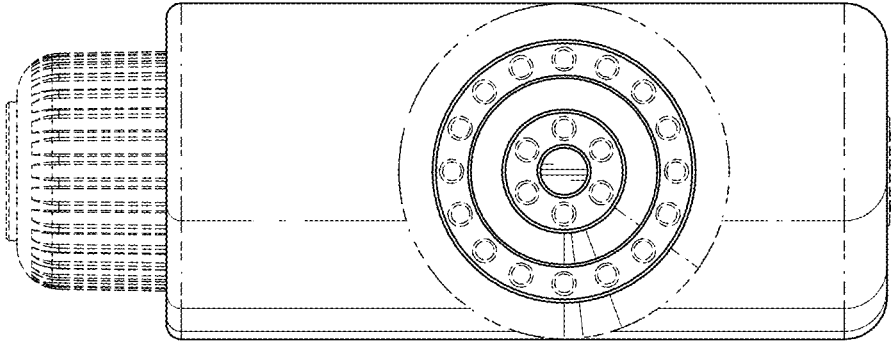

FIG. 7

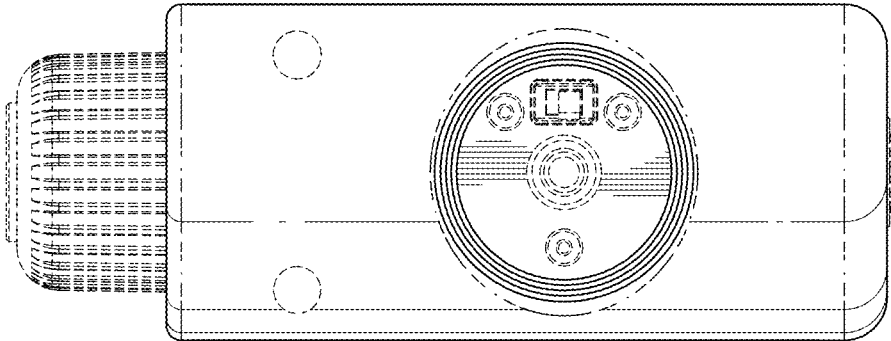

FIG. 8