

REPUBLIC OF SOUTH AFRICA
PATENTS ACT, 1978
PUBLICATION PARTICULARS AND ABSTRACT
(Section 32(3)(a) - Regulation 22 (1) (g) and (31))

OFFICIAL APPLICATION NO

LODGING DATE

ACCEPTANCE DATE

21 01
2004/6422

22
2004-08-13

43
27-09-05

INTERNATIONAL CLASSIFICATION

NOT FOR PUBLICATION

51 B41K; B41J

CLASSIFIED BY:
MORRISON FORSTER INC.

FULL NAME(S) OF APPLICANT(S)

71 SILVERBROOK RESEARCH (PTY) LTD

FULL NAME(S) OF INVENTOR(S)

72 KIA SILVERBROOK

TITLE OF INVENTION

54 DIGITAL STAMP

COUNTRY

EARLIEST PRIORITY CLAIMED
NUMBER

DATE

33 AU

31 PS 0490
PCT/AU03/00168

32 13.02.2002
12.02.2003

57 ABSTRACT (NOT MORE THAN 150
WORDS)

NUMBER OF
SHEETS 32

SEE ATTACHED SHEET

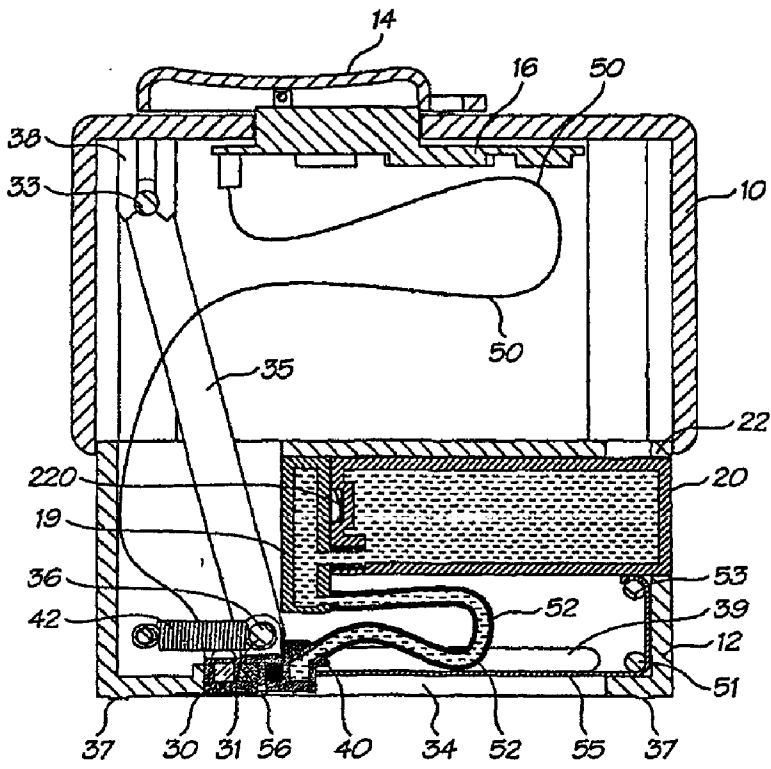

(57) Abstract: A digital stamp is described which can print out a message using a moveable inkjet printhead (30) which can be moved by a mechanical arrangement of arm (35) and pivots (33, 36). A cartridge (20) containing ink feeds the printhead (30) with monochrome or color ink via lines (52). Movement of the upper section (10) of the housing towards the lower section (12) of the housing moves the arm (35) to slide the printhead (30) across the aperture (34) in the lower section (12) while at the same time electronic signals fed to the printhead (30) print out the stored message. A spring (42) returns the printhead (30) to its inoperative position once having traversed the opening (34). The stored message may be fixed, replaceable or programmable or may be one from a fixed number of stored or updateable messages or images or can be input by an attached apparatus, for example, a CCD imager, to record an image and to print it via the printhead (30). The digital stamp can replace a rubber stamp in an office or may be used to print labels in a retail environment. An infra-red ink may also be supplied which can be used to print an encoded digital message with or on top of a visual print-out as a security measure when a printhead having the necessary number of inkjet nozzles is employed.

DIGITAL STAMP

FIELD OF THE INVENTION

5 The present invention relates to a hand held digital stamp for printing on print media, which is designed to replace existing rubber stamp devices or stencils.

BACKGROUND OF THE INVENTION

10 Rubber stamps have been known for a long time and embody a variety of constructions including a fixed face or a movable face. In the latter the inked rubber surface is moved vertically into contact with the paper or media being stamped. The stamp is normally a fixed message and cannot be altered.

15 A number of stamps are employed in an office to convey messages, for example, "Faxed"; "Copy"; or "Confirmation". This creates considerable inventory as well as a limitation that any different message requires a new stamp to be created and, once created, the new stamp has only one functional purpose.

While rubber stamps are common in office environments there are other types of markers. Stencils are one such type and it is contemplated that the instant invention may be used in place of stencils.

CO-PENDING APPLICATIONS

20 Various methods, systems and apparatus relating to the present invention are disclosed in the following co-pending applications filed by the applicant or assignee of the present invention simultaneously with the present application:

25	AP39	AP43	AP44	AP46	AP47	AP48
	AP49	AP50	AP51	AP52	AP53	AP55
	AP58	AP60	AP61	AP62	AP63	AP64
	AP65	AP66	AP67	AP68	AP69	AP70
	AP71	AP77	AP78	AP79		

30 The disclosures of these co-pending applications are incorporated herein by cross-reference. Each application is temporarily identified by its file reference. This will be replaced by the corresponding PCT Application Number when available.

35 RELATED PATENT APPLICATIONS AND PATENTS

	US6,227,652	US6,213,588	US6,213,589	US6,231,163
	US6,247,795	US6,394,581	US6,244,691	US6,257,704
	US6,416,168	US6,220,694	US6,257,705	US6,247,794
	US6,234,610	US6,247,793	US6,264,306	US6,241,342
40	US6,247,792	US6,264,307	US6,254,220	US6,234,611
	US6,302,528	US6,283,582	US6,239,821	US6,338,547
	US6,247,796	US09/113,122	US6,390,603	US6,362,843

	US6,293,653	US6,312,107	US6,227,653	US6,234,609
	US6,238,040	US6,188,415	US6,227,654	US6,209,989
	US6,247,791	US6,336,710	US6,217,153	US6,416,167
	US6,243,113	US6,283,581	US6,247,790	US6,250,953
5	US6,267,469	US6,273,544	US6,309,048	US6,420,196
	US6,443,558	US09/422,892	US6,378,989	US09/425,420
	US09/422,893	US09/609,140	US6,409,323	US6,281,912
	US09/575,113	US6,318,920	US6,488,422	US09/693,644
	US6,457,810	US6,485,135	US09/112,763	US6,331,946
10	US6,246,970	US6,442,525	US09/505,951	US09/505,147
	US09/505,952	US09/575,108	US09/575,109	US09/575,110
	US09/607,985	US6,398,332	US6,394,573	US09/606,999
	US6,238,044	US6,425,661	US6,390,605	US6,322,195
	US09/504,221	US6,480,089	US6,460,778	US6,305,788
15	US6,426,014	US6,364,453	US6,457,795	US09/556,219
	US09/556,218	US6,315,399	US6,338,548	US09/575,190
	US6,328,431	US6,328,425	US09/575,127	US6,383,833
	US6,464,332	US6,390,591	US09/575,152	US6,328,417
	US6,322,194	US09/575,177	US09/575,175	US6,417,757
20	US09/608,780	US6,428,139	US09/607,498	US09/693,079
	US09/693,135	US6,428,142	US09/692,813	US09/693,319
	US09/693,311	US6,439,908	US09/693,735	PCT/AU98/00550
	PCT/AU00/00516	PCT/AU00/00517	PCT/AU00/00511	PCT/AU00/00754
	PCT/AU00/00755	PCT/AU00/00756	PCT/AU00/00757	PCT/AU00/00095
25	PCT/AU00/00172	PCT/AU00/00338	PCT/AU00/00339	PCT/AU00/00340
	PCT/AU00/00341	PCT/AU00/00581	PCT/AU00/00580	PCT/AU00/00582
	PCT/AU00/00587	PCT/AU00/00588	PCT/AU00/00589	PCT/AU00/00583
	PCT/AU00/00593	PCT/AU00/00590	PCT/AU00/00591	PCT/AU00/00592
	PCT/AU00/00584	PCT/AU00/00585	PCT/AU00/00586	PCT/AU00/00749
30	PCT/AU00/00750	PCT/AU00/00751	PCT/AU00/00752	PCT/AU01/01332
	PCT/AU01/01318	PCT/AU00/01513	PCT/AU00/01514	PCT/AU00/01515
	PCT/AU00/01516	PCT/AU00/01517	PCT/AU00/01512	PCT/AU01/00502
	PCT/AU02/01120	PCT/AU00/00333	PCT/AU01/00141	PCT/AU01/00139
	PCT/AU01/00140	PCT/AU00/00753	PCT/AU01/01321	PCT/AU01/01322
35	PCT/AU01/01323	PCT/AU00/00594	PCT/AU00/00595	PCT/AU00/00596
	PCT/AU00/00597	PCT/AU00/00598	PCT/AU00/00741	PCT/AU00/00742

SUMMARY OF THE INVENTION

According to a first aspect of the invention there is provided a programmable marking device for printing
40 indicia on print media by movement of a printing mechanism with respect to the print media while said print

media is substantially stationary, said printing mechanism including a printing means for printing said indicia, storage means for storing in an electronic form information for printing said indicia, means for reading information from said storage means, means for writing information to said storage means, and processor means for processing said information and for controlling said printing means to print said indicia as said printing means is moved with respect to said print media.

By using a compact, movable printhead, a digital stamp can be created which can print a single message or a plurality of separate messages and can be either pre-programmed or programmable. In the latter case, the programmability of the stamp may be done via a link to a computer system, via a separate module that can be attached to the stamp device, or by some other method within the knowledge of a person skilled in the art.

Preferably, printing only occurs when said housing is in contact with print media.

Preferably, the housing has an aperture through which said printing means can print when said means for moving said printing means is operative with said housing in contact with said print media.

The means for moving the printing means may operate either manually or automatically.

Preferably, the printing means is an inkjet printhead.

Preferably, the printing mechanism includes ink supply means accommodated within said housing, which are modular and may be replaceable.

Print media includes any material suitable for printing thereon such as paper products, fabric, plastics material, metallic film or other film so treated as to allow fixing and/or absorption of the ink employed. In addition, the properties and characteristics of the ink may be adjusted to improve the fixing and/or absorption of the ink with a particular or range of print media.

BRIEF DESCRIPTION OF THE DRAWINGS

Preferred embodiments of the invention will now be described with respect to the following figures in which:

Figure 1 shows a cross sectional schematic of a stamp according to a first embodiment of the invention in a first position;

Figure 2 shows a cross sectional schematic of the stamp of Figure 1 in a second, operative position;

Figure 3, shows an underneath view of Figure 2;

Figure 4, shows an exploded view of the embodiment of Figure 1 illustrating the components thereof;

Figure 5 shows an example of use of the stamp of Figure 1;

Figure 6 shows a cartridge being mated with the body of the stamp of Figure 1;

Figure 7 shows one embodiment of a cartridge according to the invention for use with the embodiment of Figure 1;

Figure 8 shows schematically a second embodiment of the invention;

Figure 9 shows schematically a third embodiment of the invention;

Figure 10 shows schematically a fourth embodiment of the invention;

Figure 11 shows schematically a fifth embodiment of the invention: and

5 Figures 12 and 13 show schematically two alternative embodiments for positioning the printhead in the aperture of the stamp.

PREFERRED MODES OF PERFORMING THE INVENTION

10 Referring to figure 1, the stamp according to one embodiment of the invention comprises a housing having two parts, an upper part 10 and a lower part 12 with the upper part 10 of the housing moveable with respect to the lower part or base 12 of the housing. Figure 1 shows the stamp with the housing in the inoperative or extended position while figure 2 shows the stamp in its operative mode towards the end of a stamping operation.

15 Fixed to the outside of the upper housing 10 is a slide 14 which is fixed to a printed circuit board 16 on the inside of the upper housing 10. In the lower housing 12, a printhead 30 is located at one end 32 of an opening 34 in the lower housing 12 and is supplied with ink from ink cartridge 20 via ink connector 19 and tubes 52. The printed circuit board (PCB) 16 has the necessary solid state memory 15 and processing capabilities to operate the printhead 30 and control other function within the stamp housing, such as detecting the presence
20 or absence of an ink cartridge 20. Solid state memory includes, for example, ROM, PROM, EEPROM or low power consumption RAM such as CMOS, DRAM or SRAM devices.

Slide 14 is used to select what indicia are to be printed as stored in memory 15. The slide 14 may be a potentiometer whose resistance value is interpreted by circuitry on PCB 16 to select a print choice from
25 memory 15, or may be a selector switch which chooses the required print by contacting conductor strips or fingers on PCB 16 which strips are coded for the desired location in memory 15. The selector switch may be a linear slide switch, as shown, or may be a rotary switch.

30 A battery (not shown) for operating the printhead 30 can be accommodated in or associated with the ink cartridge 20, which is supported on base moulding 22.

The printhead 30 moves across the opening 34 and in doing so prints the selected indicia 24, characteristic of the stamp, for example as illustrated in figure 5, on print media 26. The printhead 30 may be moved by an electrical motor or by various mechanical arrangements or a combination of motor and mechanical linkage.
35 Typical mechanical arrangements may be rack and pinion, peg and groove or rack and pinion and worm screw.

In the embodiment shown in figure 1, the printhead 30 is moved across the opening 34 by a mechanical mechanism comprising a pair of arms 35 fixed at one end to the top 36 of the printhead 30 by axle 31 and at
40 their other end to a bracket 38 of the upper housing 10 by axle 33. A pair of pulley wheels or bearings 37

fixed to printhead 30 (see Fig.4) engage in slot 39 to constrain the motion of the printhead 30 to a linear motion across the opening 34. As the upper housing 10 is moved toward the lower housing 12 by manual action the arms 35 move the printhead 30 from left, as shown in figure 1, to the right, as shown in figure 2. At the same time, the printhead 30 is activated to print the indicia required. The printhead 30 is supplied with
5 information and activating signals from the processing circuitry on PCB 16 via the wires 50 and with ink from the ink cartridge 20 via ink connector 19 and tubes 52. A four ink (red, yellow, cyan, black) printhead is illustrated although printheads having from one to six inks can be employed as disclosed in applicant's applications listed in the appendix.

10 A return spring 42 is fixed between a stationary part 47 of the lower housing 12 and axle 31 on printhead 30 and ensures that the printhead 30 and upper housing 10 will return to their initial starting positions as shown in figure 1, upon release of the pressure from the upper housing 10.

A tambour or shutter 55 covers the opening 34 when the stamp is not in use (see Fig.1). The tambour 55 is
15 attached to the ledge 40 of printhead 30. As the printhead 30 moves across the opening 34 the tambour 55 is moved around the rollers or bearings 51, 53 and along the base of the ink cartridge 20. The tambour 55 is shown in its fully retracted state in Figure 2. When spring 42 returns the printhead 30 to its rest position, the tambour 55 is drawn back to cover the opening 34 as shown in figure 1.

20 A copper arm 56 extends from the lower housing 12 to cover the printhead 30 when in the "home position" as shown in figure 1. In this way the face of the printhead 30 is protected from dirt and damage. The copper arm 56 may further include a sponge or other absorbent material for collecting drips or extraneous ink between runs of the printhead 30. The copper arm 56 may also act as a lever to contact a microswitch (not
25 shown) when the arm 56 is pressed onto print media to activate the circuitry controlling the printing by printhead 30. A pair of rubber feet 37 supports the lower housing 12 and hence printhead 30 away from any support surface or the surface of the print media when printing. Printhead 30 is an inkjet printhead and the thickness of the feet 37 spaces the printhead 30 from the print media without interfering in the operation thereof.

30 A sensor (not shown) for example, a CCD image sensor, may be provided on the side of the printhead 30 to detect the position of the printhead 30 with respect to the housing to co-ordinate printing by the printhead 30. Signals from the CCD image sensor are fed to circuitry on PCB (printed circuit board) 16 for processing. This circuitry controls the operations of the printhead 30. The printhead 30 is a type of electromechanically driven inkjet printhead and the circuitry provides the signals to the respective ink nozzles required to print the
35 message stored in ROM or RAM on the PCB 16.

The ink cartridge 20 is replaceable so that the stamp can be reused once the ink supply has been exhausted. It is also contemplated that a stamp may be used once only and therefore that the ink cartridge 20 is not designed to be replaceable in some forms of the invention.

One embodiment of a replaceable cartridge 20 is shown in Figure 7. It comprises a body 200 having flanges 202 at the front face 204 for grabbing and wedge-shaped cut-outs 206 at the sides 208 for mating with complimentary structures on the inside of the side walls 210 of the lower housing 12. Ink outlets 212, four in number are shown, provide access to separate internal compartments storing each of the four inks. A printed circuit chip 214 is fixed to the rear 216 of the cartridge 20 and is encoded with details of the cartridge 20 such as the features (number, colours) and characteristics (viscosity, use by date) of the ink or inks used so that when inserted into the housing the chip 214 contacts a receiving connector dock 220 (see Figure 6) whereby these details may be read by the processing circuitry on PCB 16. The ink outlets 212 mate with inlet sockets 222 on the ink connector 19. The connector 19 is provided with means for rupturing seals (not shown) in the ink outlets 212 of the cartridge 20 when the cartridge 20 is first installed. For example, the inlets 222 may have sharp metal edges for doing this. The ink cartridge 20 may also include a battery pack with enough energy to operate the printhead 30 for the duration of the ink supply. Alternatively, provision for a battery pack may be provided elsewhere within the housing to fulfil these requirements or to supplement them.

The printhead 30 can be of a type of sufficient size and detail to print across and along the opening 34 but preferably involves an inkjet printhead of a type such as disclosed in the inventor's earlier applications as listed below in the Appendix.

The stamp according to the invention may be operated mechanically, as described above, or may be operated fully electrically, in which case the upper housing need not be made moveable with respect to the base housing but the two housings could be of a fixed configuration.

Other ways of moving the printhead 30 are also contemplated, including using a DC or an AC motor under internal power or through an external power connection. Regulation of the motion of the printhead 30 may be provided by a mechanical governor or by the control circuitry for the motor such as by using a stepper motor or a synchronous AC motor.

As an alternative to the CCD image sensor, positioning of the printhead 30 may be sensed by an optical quadrature wheel.

If the stamp is electrically powered, the power may be provided internally either from a separate battery pack, from a battery integral with the ink cartridge, from a generator or dynamo operated when the upper housing is moved downwardly, as described above, or by an external wired connection, for example a USB (universal serial bus) connection (see Figure 9).

Various embodiments of the stamp are contemplated and four further embodiments thereof are shown in figures 8-11 respectively.

In figure 8, a pre-programmed stamp is shown. A fixed message is, for example, provided in a ROM associated with the circuitry driving the printhead. The message may be displayed on an LCD 60 on the face

of the stamp and may be further programmable by a set of select buttons, keys or toggles 62 which may, for example, present a time or a date to be printed out with the fixed word, message or image.

5 In figure 9, a programmable stamp is shown which has a connector socket 70, for example a USB (universal serial bus) connector for connecting to a portable or fixed computer which can be used to program or provide input via the USB to the stamp for printing out a message made up via the keyboard or mouse of said portable or fixed computer.

10 In the embodiment shown in figure 10, a stamp is made with a removable module 80 which can be clipped onto top housing 10 and has a number of selectable printable elements 82 which can be selected by the selection dial 84. For example, the material that may be selected may be character images of a type such as Mickey Mouse, or Simpsons characters. Module 80 may be removed and replaced by a separate module 90 to provide a different selection of characters allowing the stamp to be selectively "programmed". Contacts 86 in the base of a module 80, 90 allow the information for the printing of the selected character(s) to be transferred
15 to the processing circuitry of the stamp housing.

As shown in figure 11, a stamp is provided which has an attached lens 100, view finder 102 and image sensor 104, the latter two for example being a LCD 102 and a charge coupled device (CCD) 104 respectively, making in effect a miniature camera. The CCD 104 can be used to take a picture of a scene using the button
20 106 while displaying the scene on the viewfinder 102. The image can then be stored and printed out using the printhead 30 in the manner such as disclosed in the applicant's Artcam applications for example as described in US Patent 6,152,619. The stamp may also be provided with a processor unit that can add other details to the image taken by the CCD 104, for example, the time and date or some text. The stamp may also be provided with a programmable input, such as disclosed with respect to the embodiment of figure 9, whereby,
25 for example, the time and date or the name of the author of the photograph or image may be applied thereto when printed out.

The stamp may be used to replace the prior art rubber stamps used in office environments but may also be used in a variety of other situations, for example, to print a barcode and/or price on a tag or label with the tag
30 or label fixed to the product or separate therefrom. In the latter case, an embodiment such as described with respect to figure 9 may be used whereby the stamp is connected via a connector such as an USB to the inventory computer in a supermarket or retail store which loads the details of a barcode and/or price for printing by the printhead 30. The printhead 30 is, for example, as described in US Patent 6,152,619 a linear inkjet printhead having from 1 up to 6 colour jets which are arranged in a linear columnar configuration
35 printing a column of dots in each colour as the printhead traverses the aperture in the base of the stamp. The printhead 30 may be positioned in the opening 250 in the base 252 of the stamp to move along either the long axis 254 or the short axis 256 of the opening 250 as shown respectively in Figures 12 and 13. Such printheads may have a resolution of up to 1600 dots per inch allowing the printing of a detailed monochrome or colour strip. In addition, if an infra-red ink is used an invisible watermark or security code may be included with the
40 visible printed matter. The width of the strip will vary depending upon the size of the printhead used but a

print head has a typical width of 5-8mm. A wider printhead can be provided by overlapping more than one such printhead.

5 The foregoing description has been limited to specific embodiments of this invention. It will be apparent, however, that variations and modifications may be made to the invention, with the attainment of some or all of the advantages of the invention. For example, it will be appreciated that the invention may be embodied in hardware and/or software in a suitably programmed device, both aspects of which are readily accomplished by those of ordinary skill in the respective arts. Therefore, it is the object of the appended claims to cover all such variations and modifications as come within the true spirit and scope of the invention.

10

CLAIMS

1. A programmable marking device for printing indicia on print media by movement of a printing mechanism with respect to the print media while said print media is substantially stationary, said printing mechanism including a printing means for printing said indicia, storage means for storing in an electronic form information for printing said indicia, means for reading information from said storage means, means for writing information to said storage means, and processor means for processing said information and for controlling said printing means to print said indicia as said printing means is moved with respect to said print media.
2. A programmable marking device as claimed in claim 1, wherein said means for writing information to said storage means includes connector means for connecting said storage means to an external processor means.
3. A programmable marking device as claimed in claim 1, wherein said storage means are programmable solid state memory means.
4. A programmable marking device as claimed in claim 1, further wherein said means for writing information includes a removable module engaging a connector of the device, said module being programmed with information for printing a plurality of indicia, the programmable device further including means for selecting one or more of said indicia to be printed by said printing means.
5. A programmable marking device as claimed in claim 1, further including an inbuilt camera comprising lens, an imaging CCD and a view finder and further including switch means for activating said inbuilt camera, said processor means for controlling said printing means including a processor means for processing an image captured by said inbuilt camera means and printing out said image using said printing means.
6. A programmable marking device as claimed in claim 5 wherein said printing means is an inkjet printhead.
7. A programmable marking device as claimed in claim 2, wherein said connector means includes a Universal Serial Bus connector.
8. A programmable marking device as claimed in claim 1, further including a base housing and an upper housing moveable with respect to each other between a rest position and an end position, the device being configured such that relative movement from the rest position to the end position causes movement of the printing means in a printing movement from a start position to a finish position relative to a substrate upon which the device is being used.
9. A programmable marking device as claimed in claim 8, including moving means for generating the printing movement, the moving means including an arm pivotally connected to a fixed point of said upper housing at one end and pivotally connected at the other end to said printing means, and further including a resilient means attached to said printing means for returning said printing means to said rest position after said end position has

been reached.

10. A programmable marking device as claimed in claim 9, wherein said printing mechanism includes an ink supply means; said printing means comprises an inkjet printhead; said means for controlling said printing means
5 comprises microprocessor means and said storage means includes solid state memory means for storing the information required to print said indicia, the marking device including means for connecting said ink supply means to said printing means to convey ink to said inkjet printhead.

11. A programmable marking device as claimed in claim 10, wherein said ink supply means includes a supply of a plurality of inks, said connecting means includes a corresponding plurality of respective connections,
10 said printhead including a corresponding plurality of sets of inkjet nozzles for printing with said plurality of inks.

12. A programmable marking device as claimed in claim 11, wherein said ink supply means includes means storing at least one ink and said printhead includes a plurality of inkjet nozzles for printing with at least said one
15 ink.

13. A programmable marking device as claimed in claim 12, wherein said ink supply means includes means storing at least an infrared ink and another ink, said printhead including a plurality of inkjet nozzles for printing with at the two inks.
20

14. A programmable marking device as claimed in claim 11 wherein said ink supply means is replaceable.

15. A programmable marking device as claimed in claim 12 wherein said ink supply means is replaceable.

25 16. A programmable marking device as claimed in claim 13 wherein said ink supply means is replaceable.

17. A marking device as claimed in claim 2, configured to convert downward movement of the upper housing supplied by a user's hand into lateral movement of the printing means.

30 18. A marking device as claimed in claim 1, wherein one of the components is an inkjet printhead comprising a plurality of nozzles formed by microelectromechanical means.

19. The device of claim 18, wherein the inkjet printhead is a full color printhead.

35 20. A marking device as claimed in claim 1, further including a safety mechanism that only allows printing to take place when the device is in an operative position with respect to a substrate.

40 21. A marking device as claimed in claim 20, wherein the safety mechanism comprises a switch that is normally open, and is configured to close when the marking device is urged into contact with the substrate.

22. A marking device as claimed in claim 2, wherein the base housing includes an aperture disposed, in use, adjacent and substantially parallel to the substrate.

5 23. A marking device as claimed in claim 22, wherein the aperture includes one or more marking lines or formations indicative of an area to be printed during operation of the marking device.

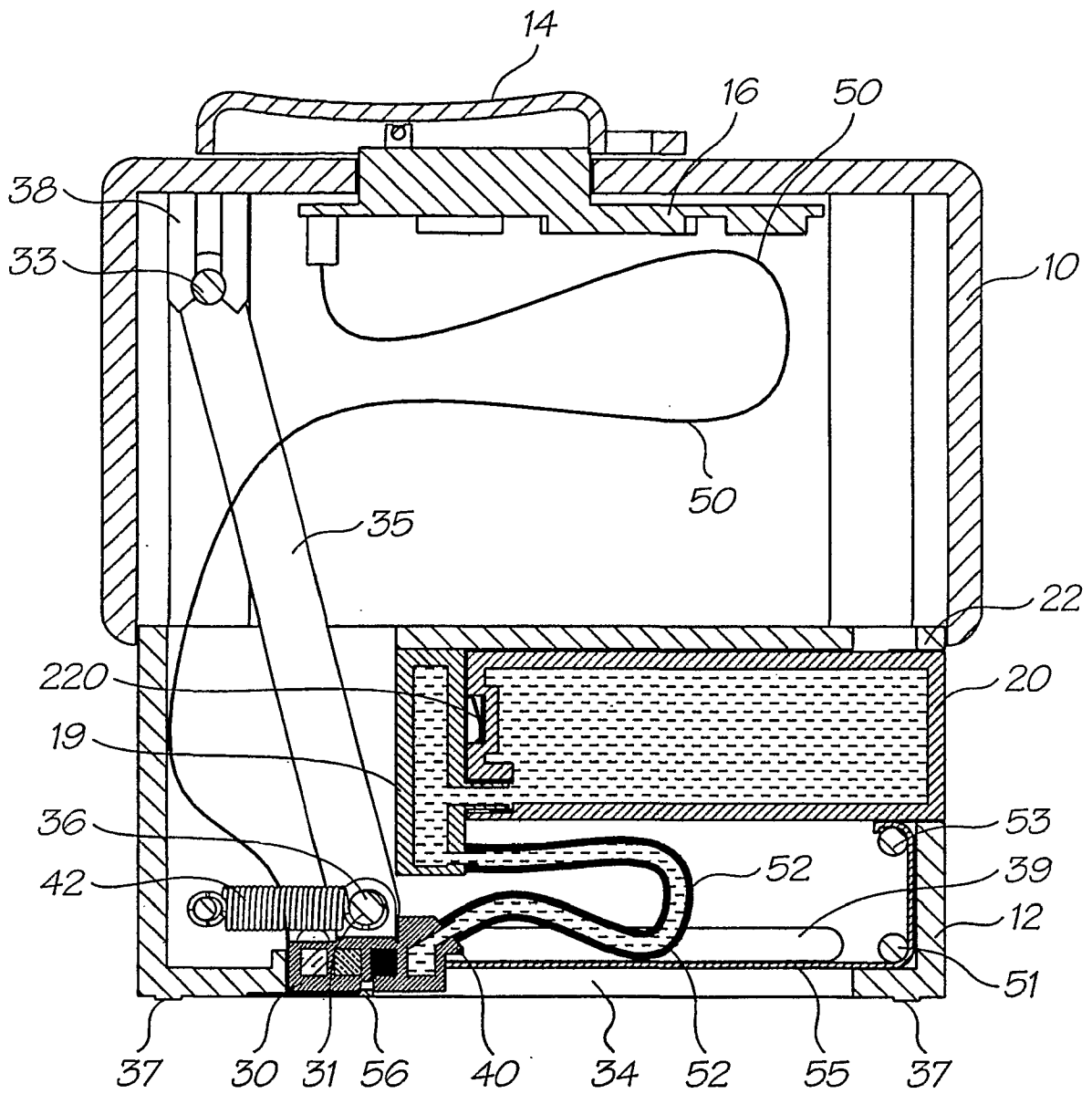

FIG. 1

2/11

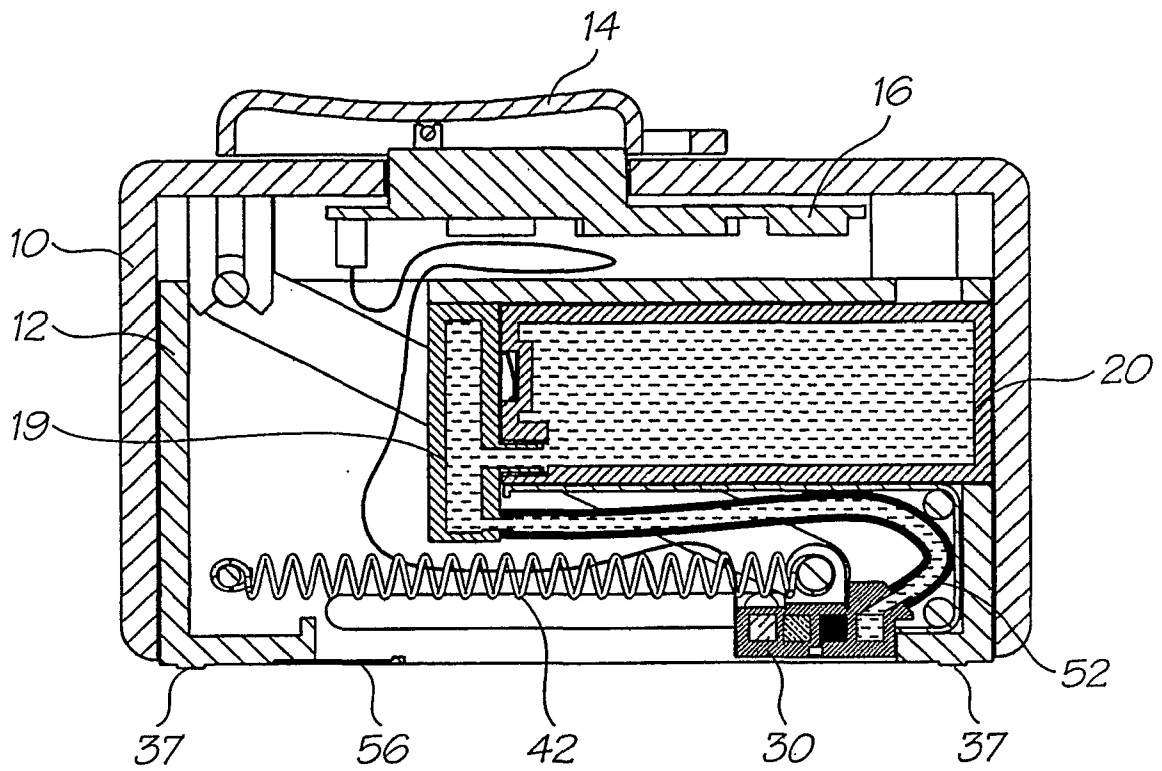

FIG. 2

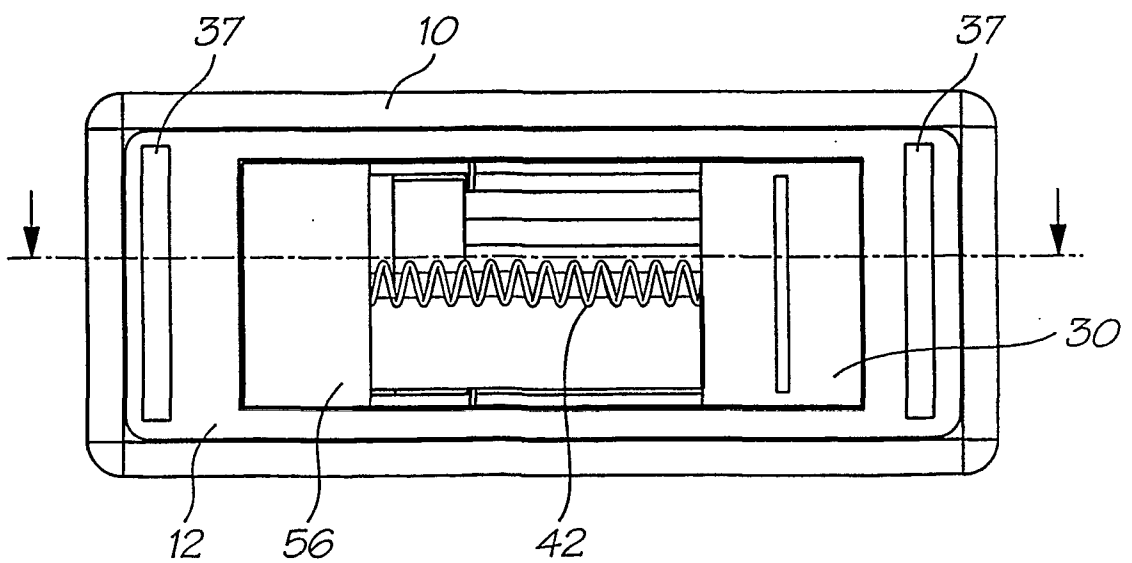

FIG. 3

3/11

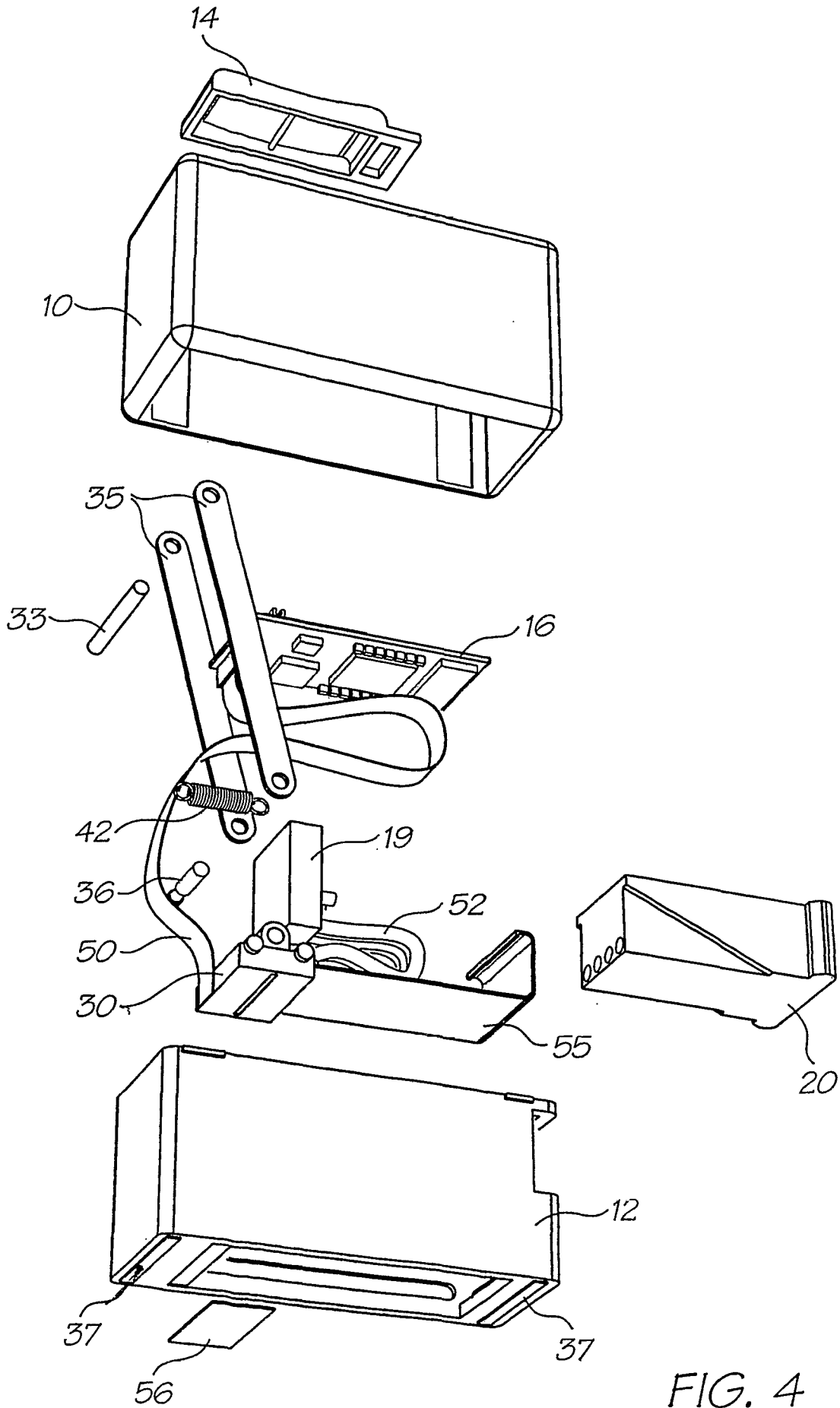

FIG. 4

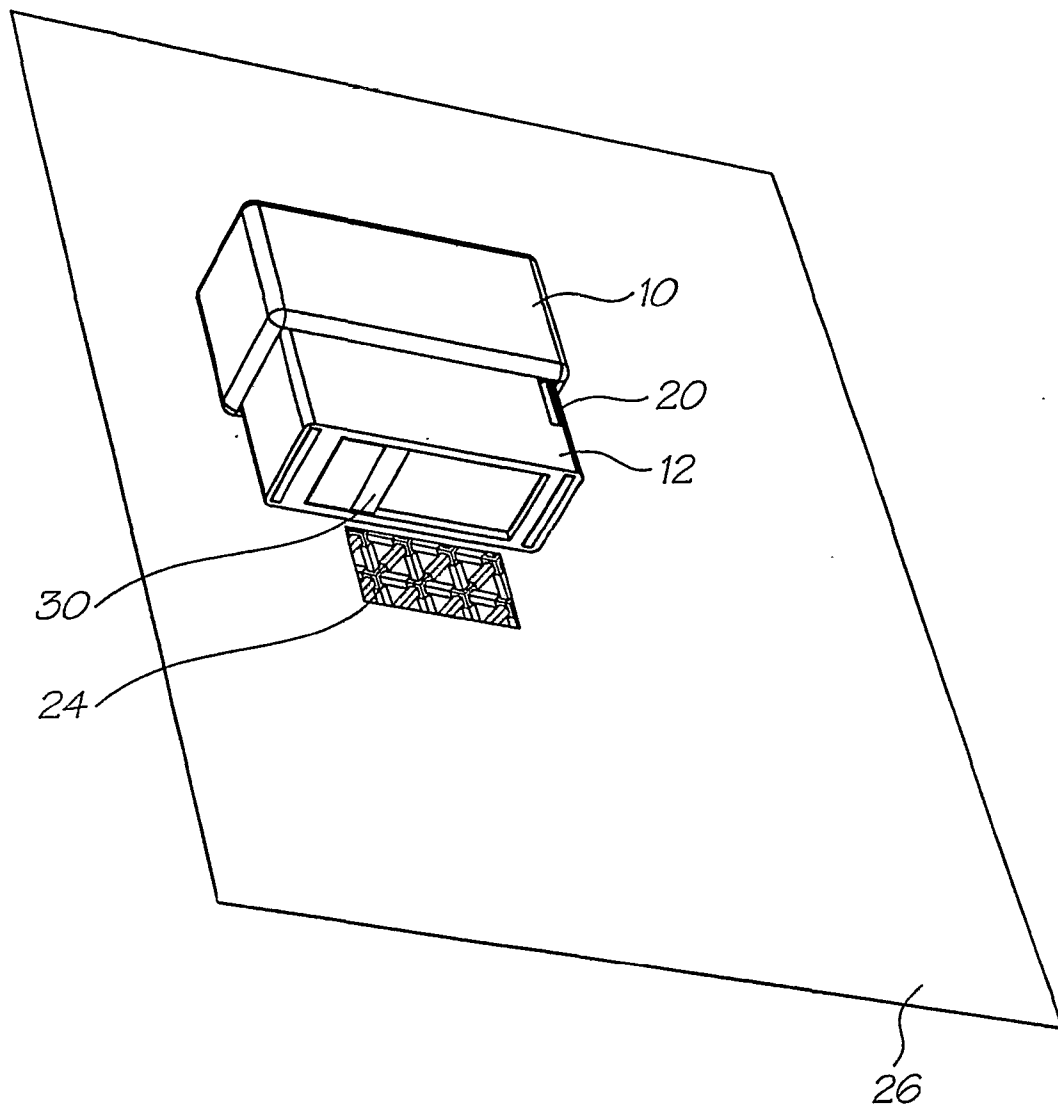

FIG. 5

5/11

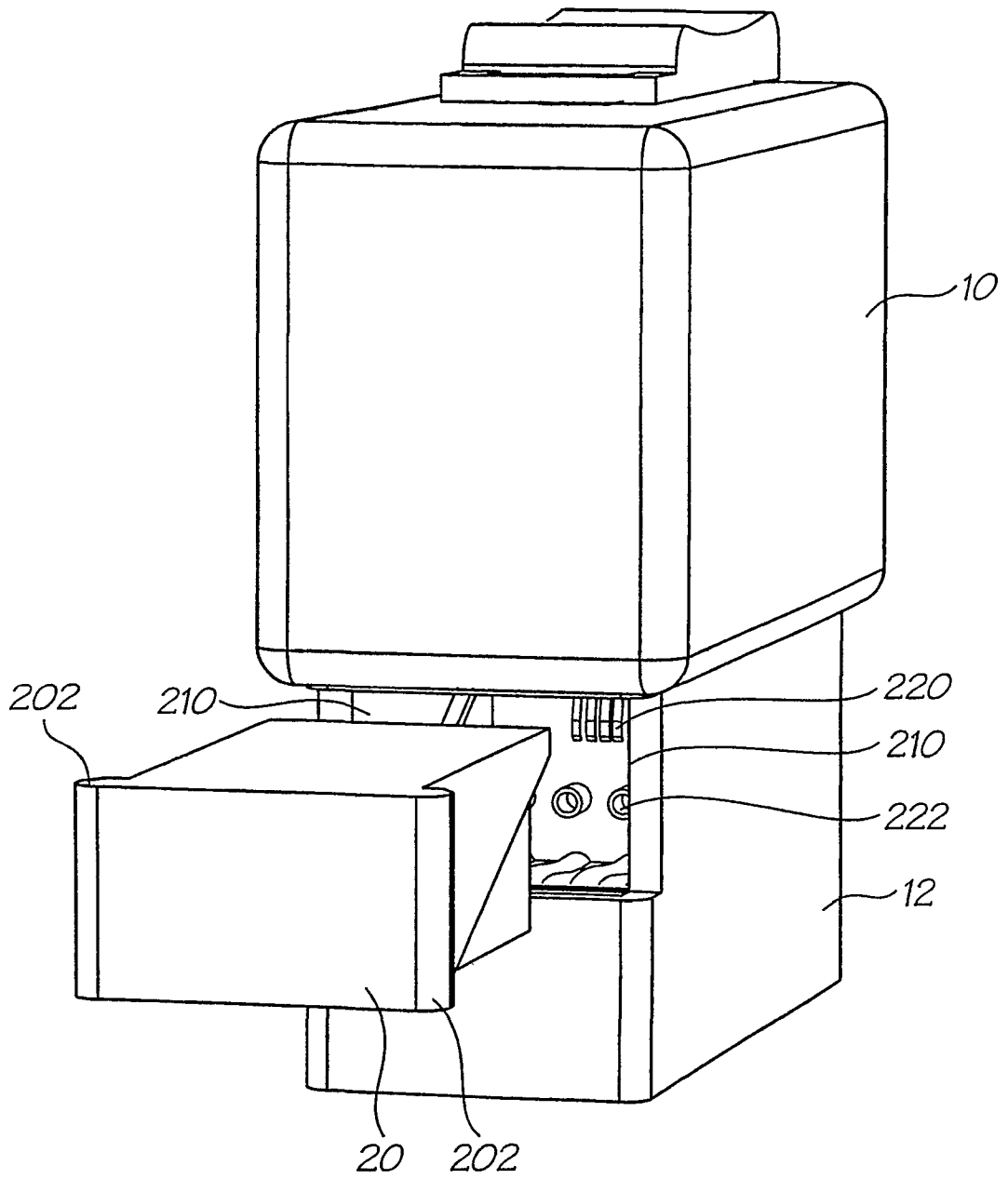

FIG. 6

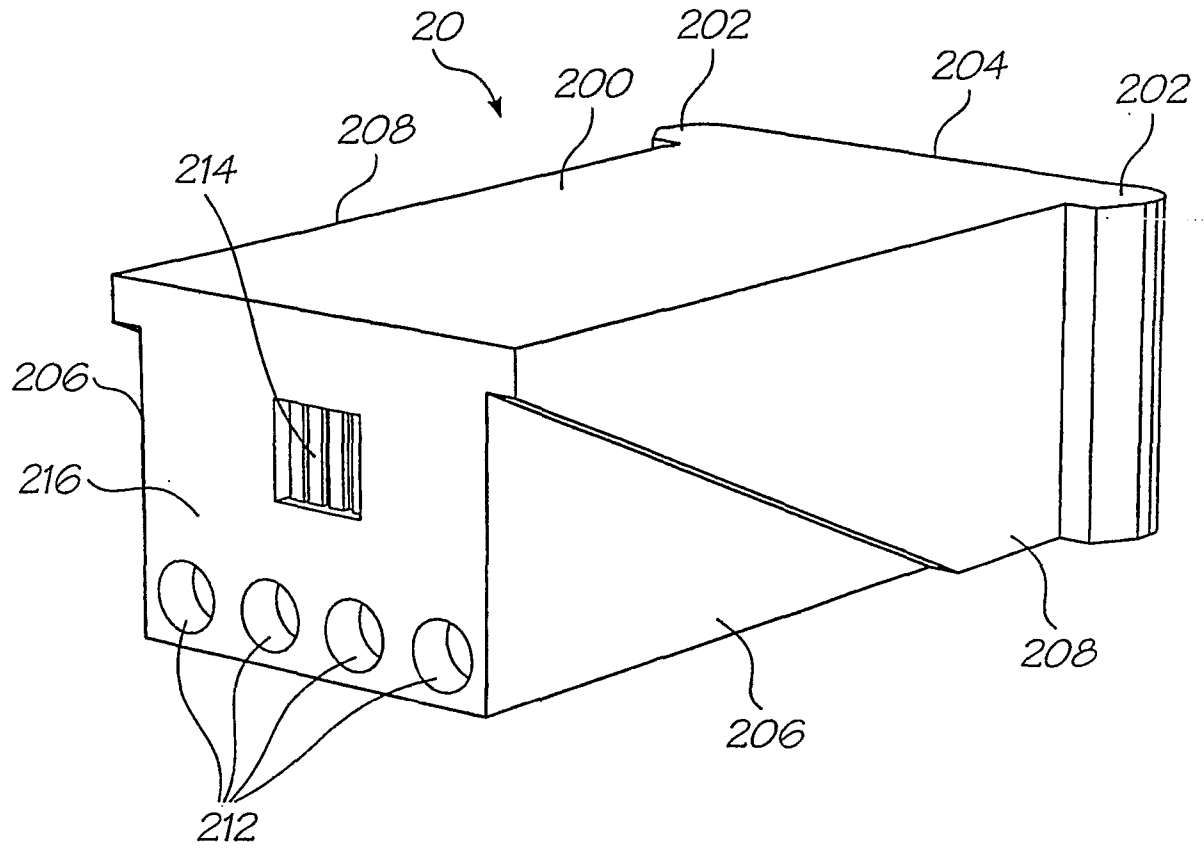

FIG. 7

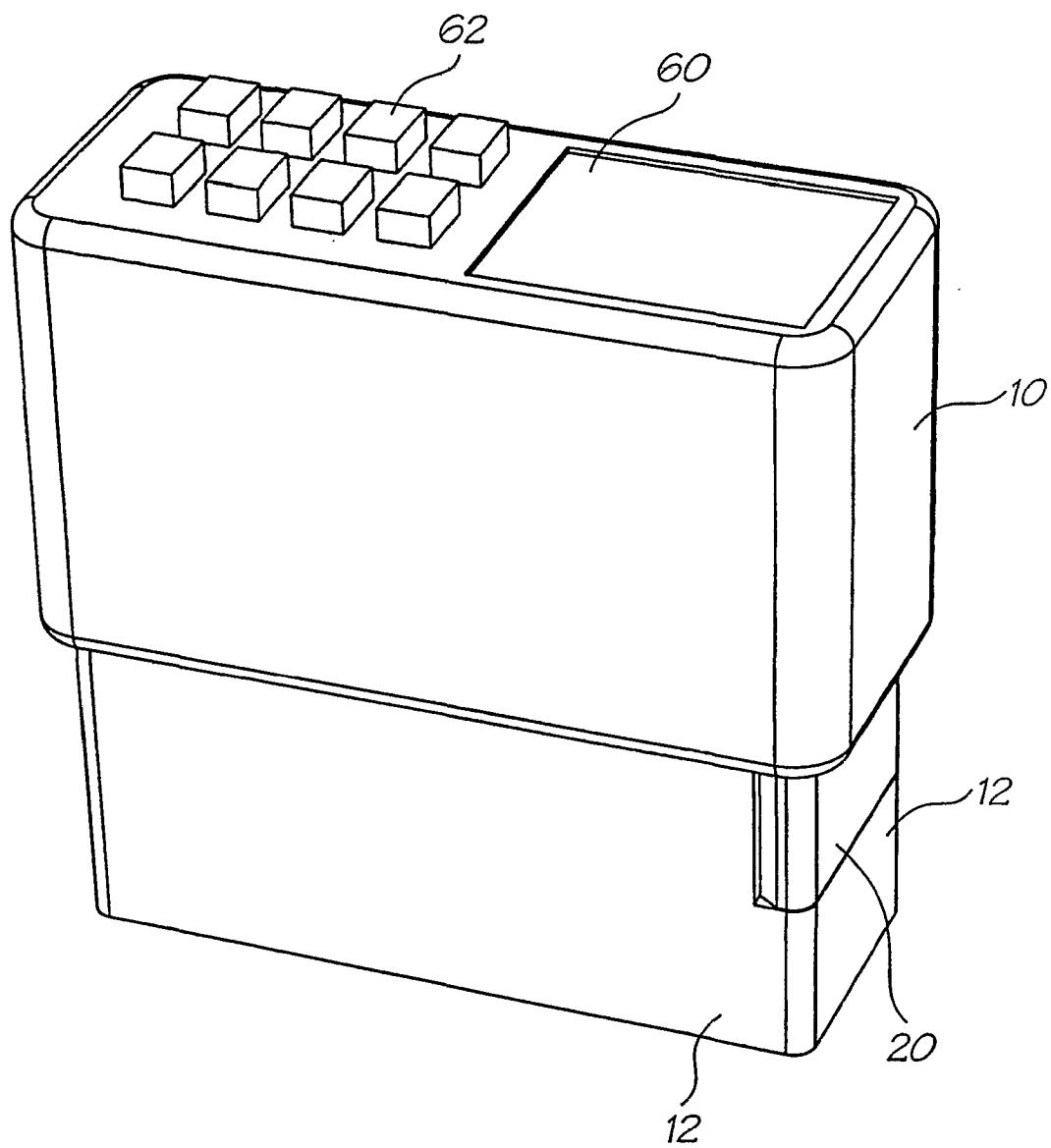

FIG. 8

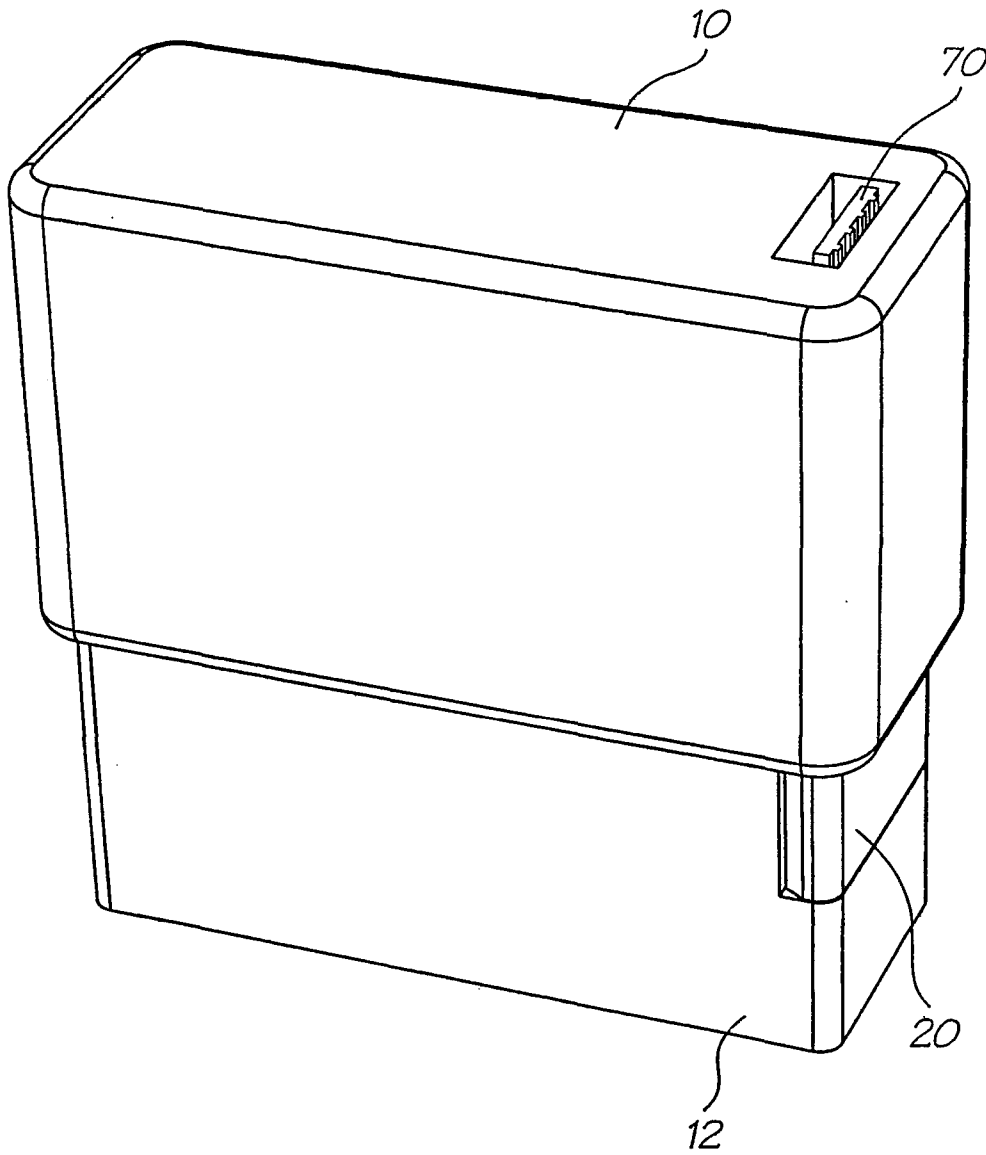

FIG. 9

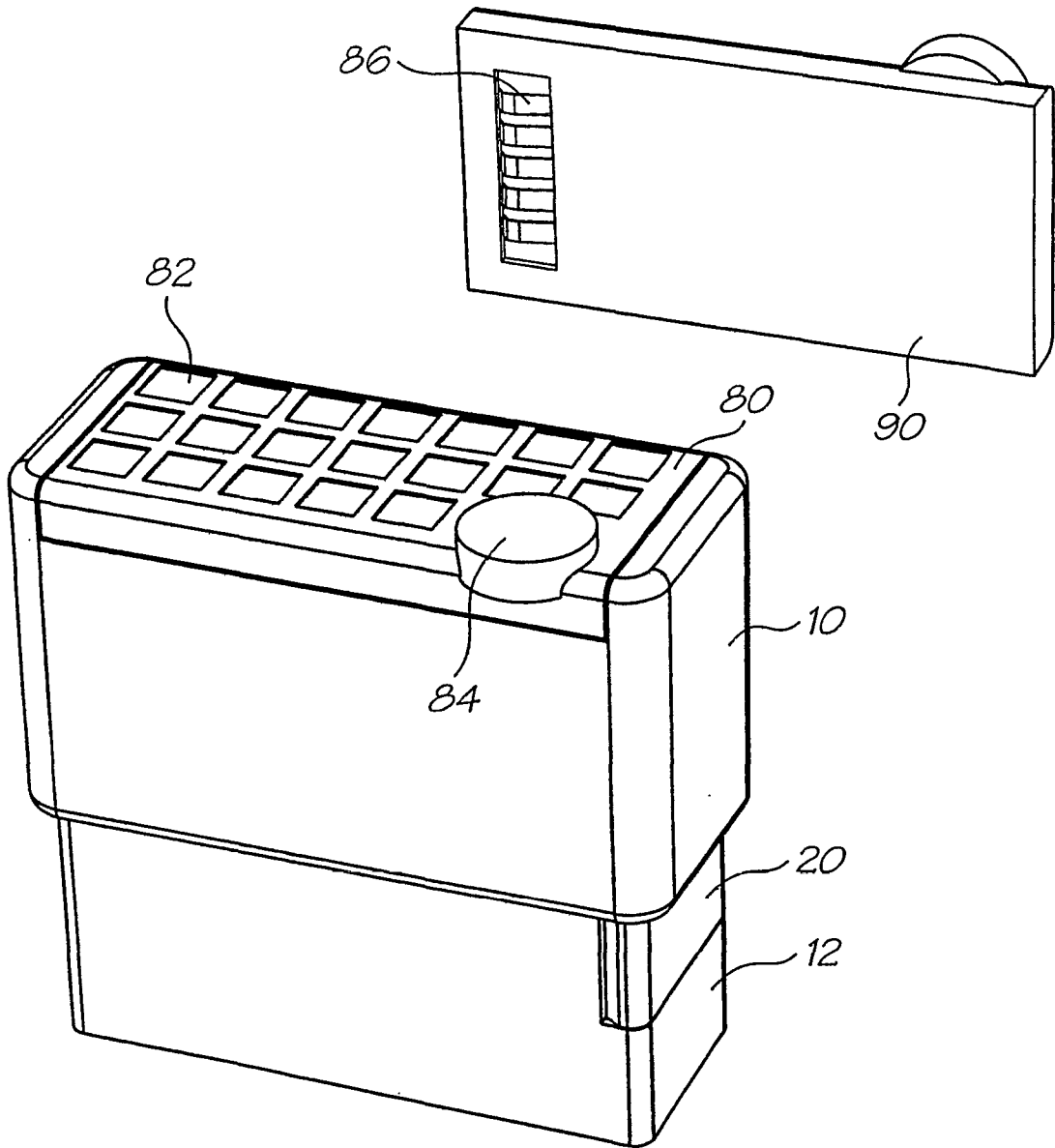

FIG. 10

10/11

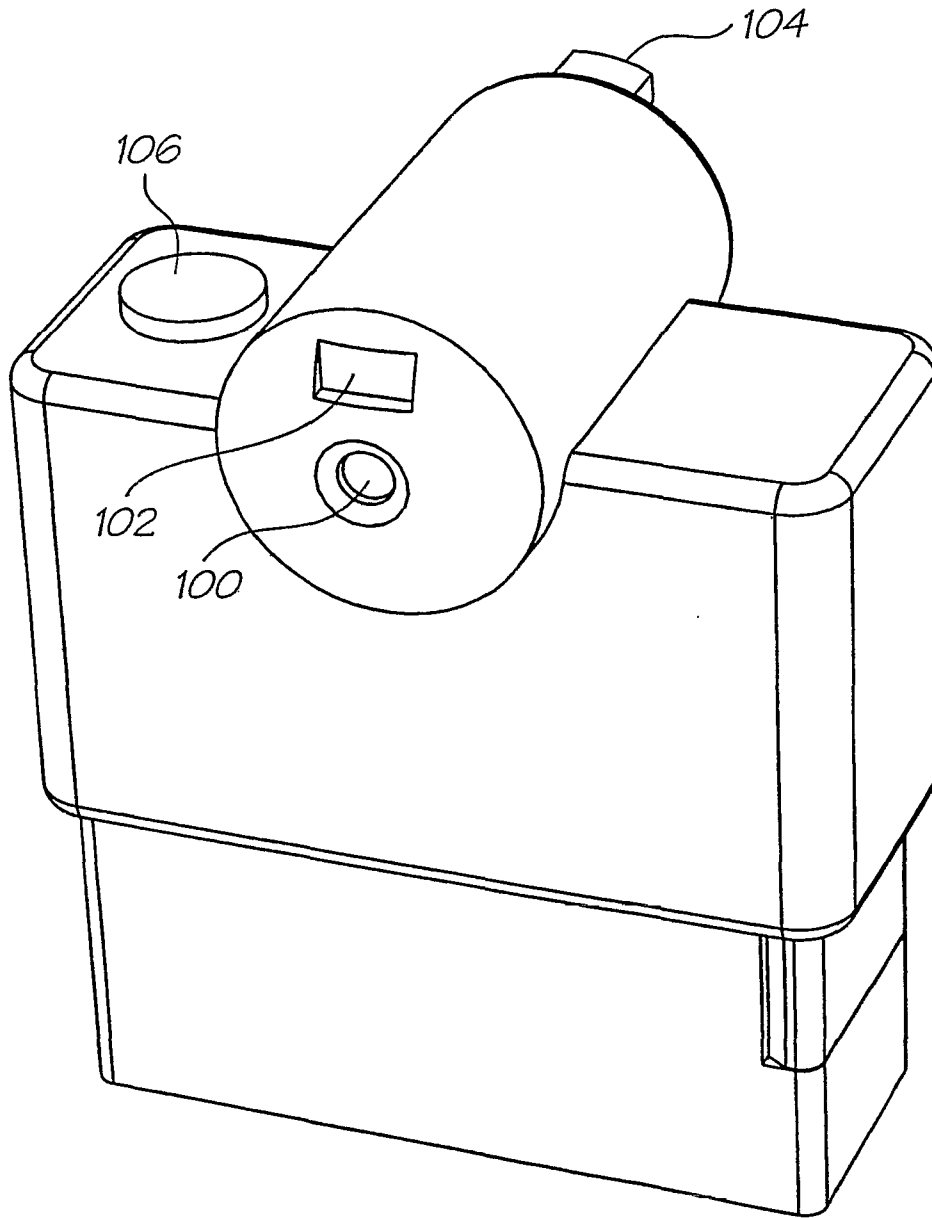

FIG. 11

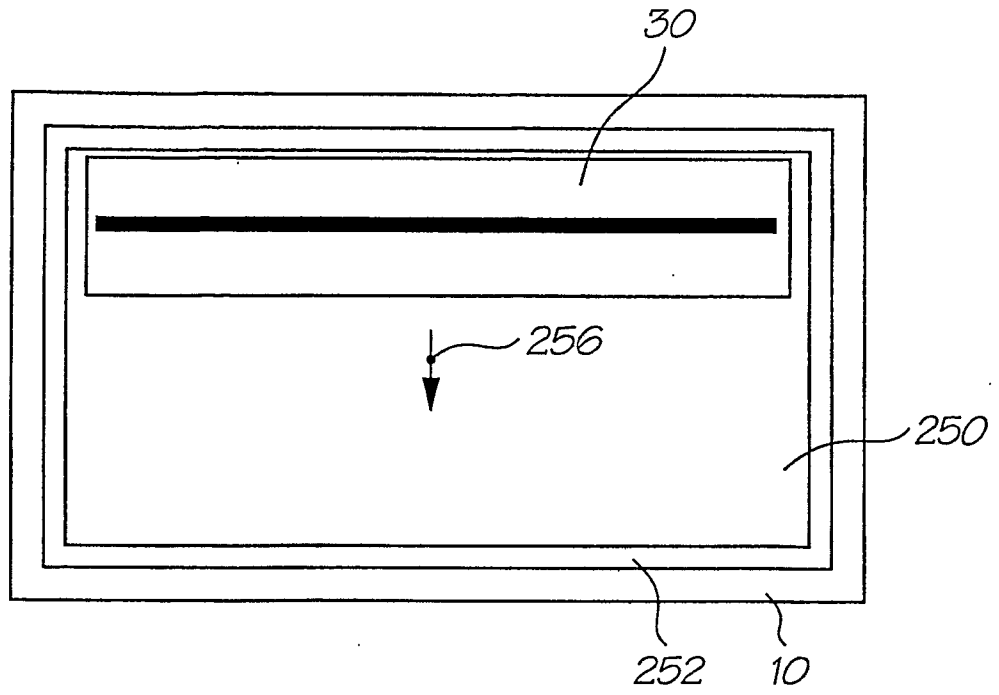

FIG. 13

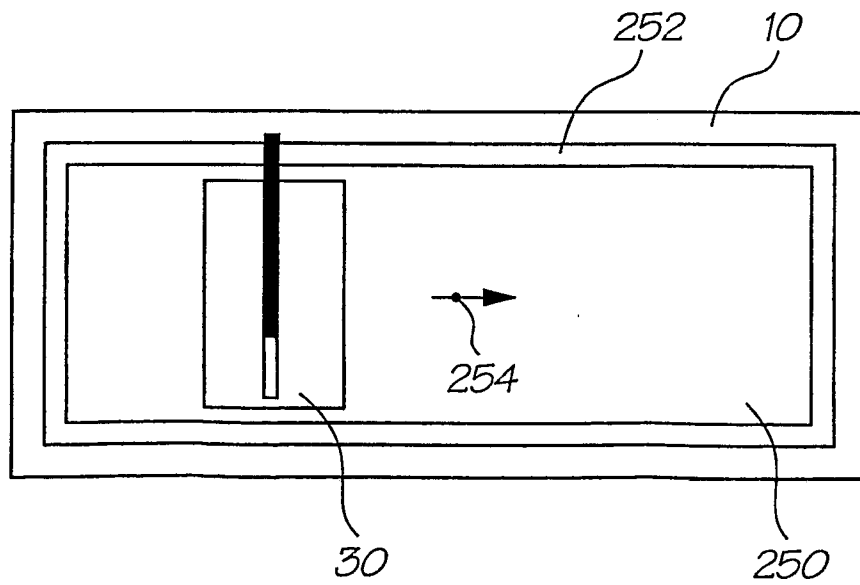

FIG. 12