



US 20150230687A1

(19) **United States**

(12) **Patent Application Publication**
Dries et al.

(10) **Pub. No.: US 2015/0230687 A1**

(43) **Pub. Date: Aug. 20, 2015**

(54) **SPRAY ARM ASSEMBLY FOR DISHWASHER APPLIANCES**

(52) **U.S. Cl.**
CPC *A47L 15/23* (2013.01)

(71) Applicant: **General Electric Company,**
Schenectady, NY (US)

(57) **ABSTRACT**

(72) Inventors: **John Edward Dries,** Louisville, KY (US); **Joel Charles Boyer,** Louisville, KY (US); **Kyle Edward Durham,** Louisville, KY (US)

Dishwasher appliances and spray arm assemblies for dishwasher appliances are provided. An assembly includes an indexing assembly disposed between a conduit and a plurality of spray arms. The indexing assembly includes a disk rotatable about an axis and movable along an axial direction between a first position and a second position, the disk defining an aperture and a channel and comprising a plurality of cams projecting into the channel. The indexing assembly further includes a biasing element configured to urge the disk into the first position, and a boss assembly, the boss assembly comprising a boss extending into the channel of the disk, the boss defining a plurality of guide elements. The guide elements and cams are configured to interact such that movement of the disk along the axial direction between the first position and the second position causes the disk to rotate about the axis.

(73) Assignee: **General Electric Company,**
Schenectady, NY (US)

(21) Appl. No.: **14/181,768**

(22) Filed: **Feb. 17, 2014**

Publication Classification

(51) **Int. Cl.**
A47L 15/23 (2006.01)

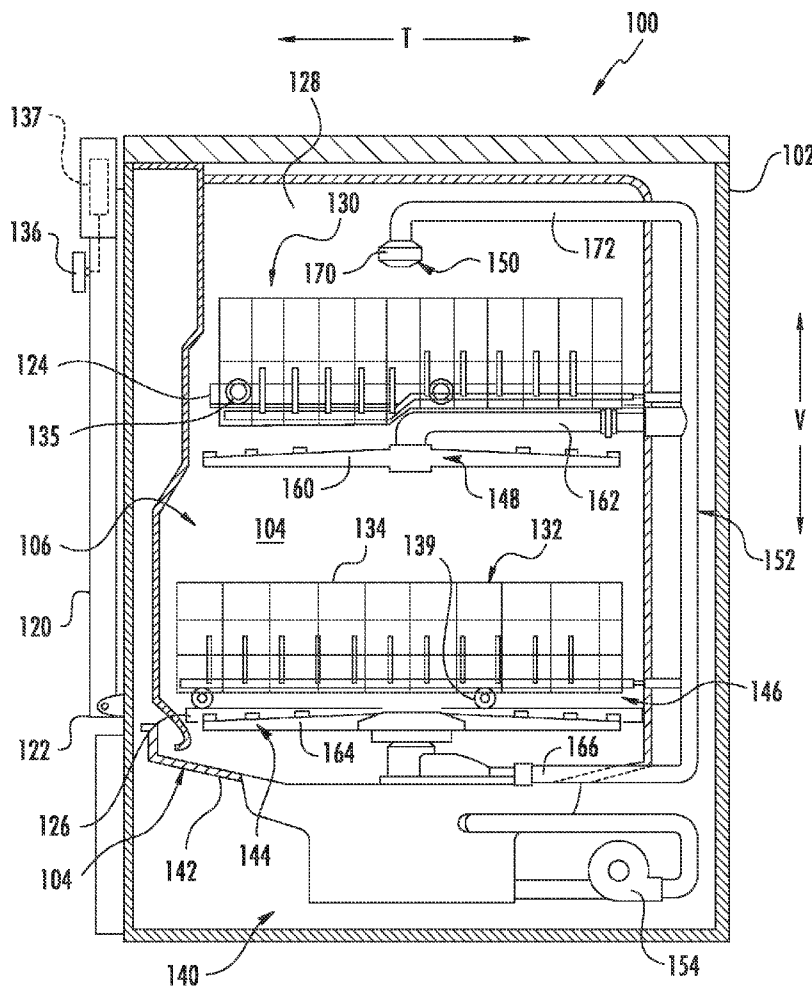

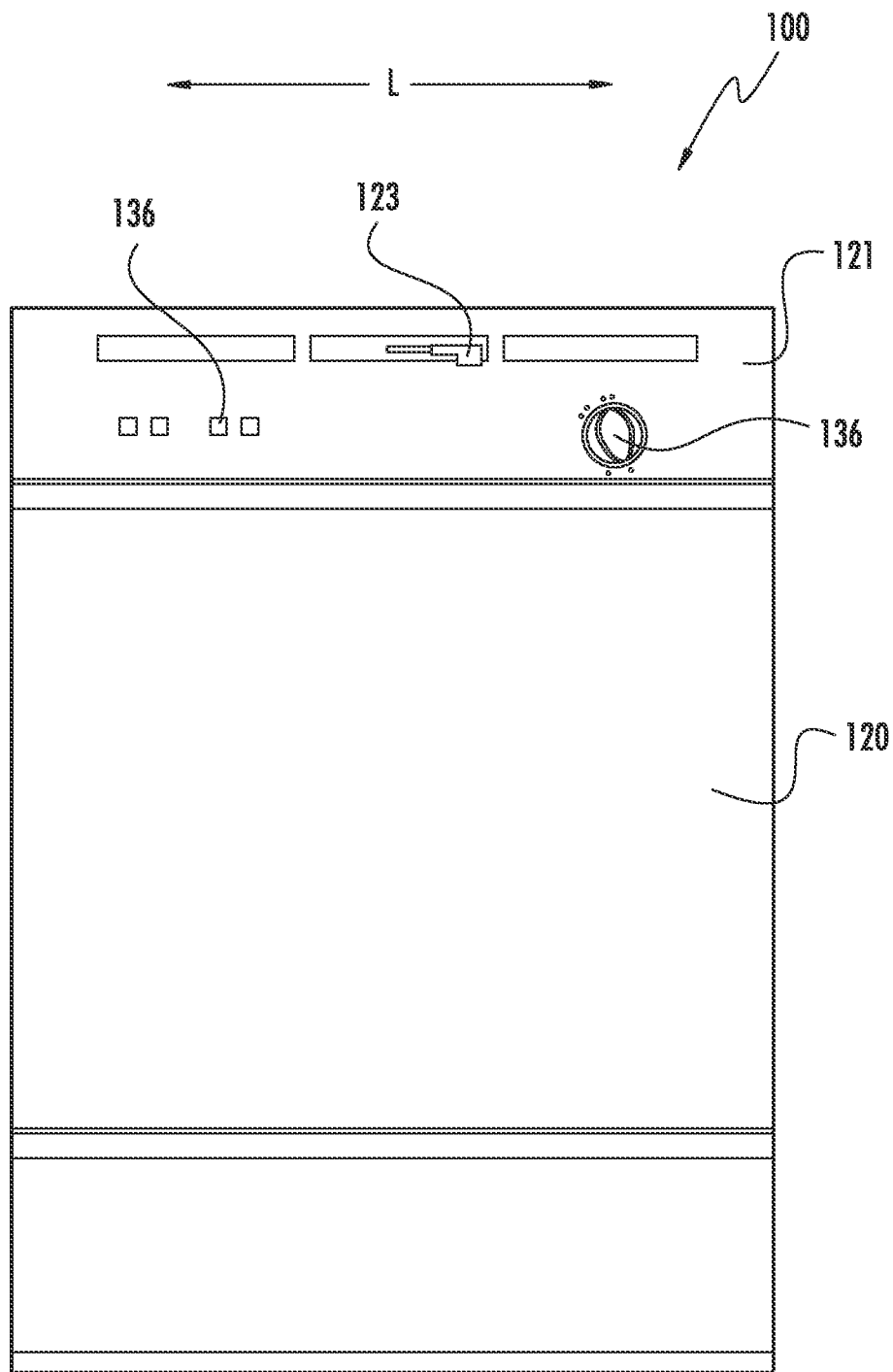

FIG. 1

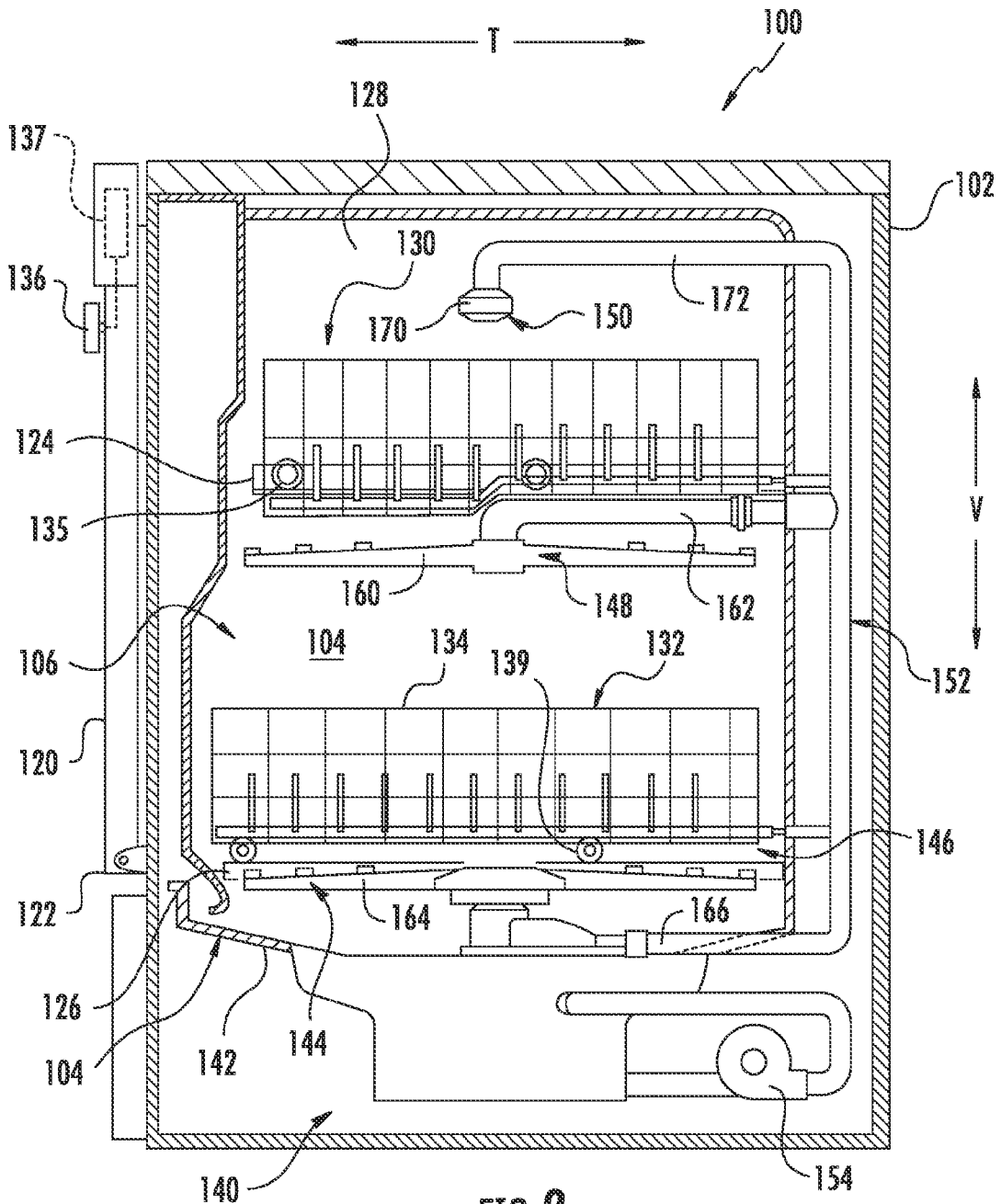
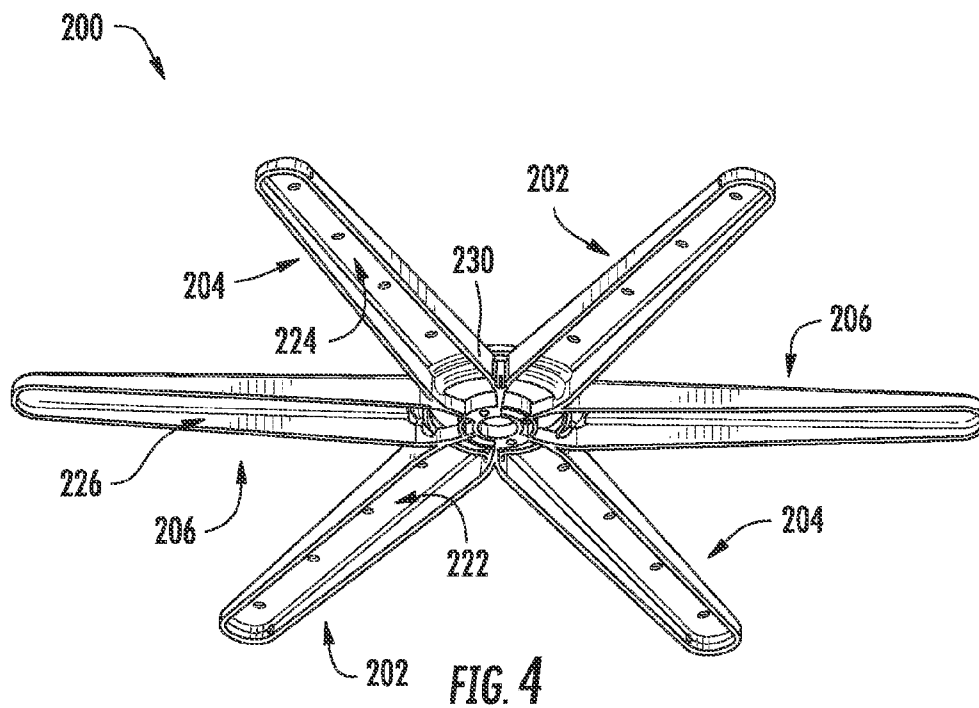
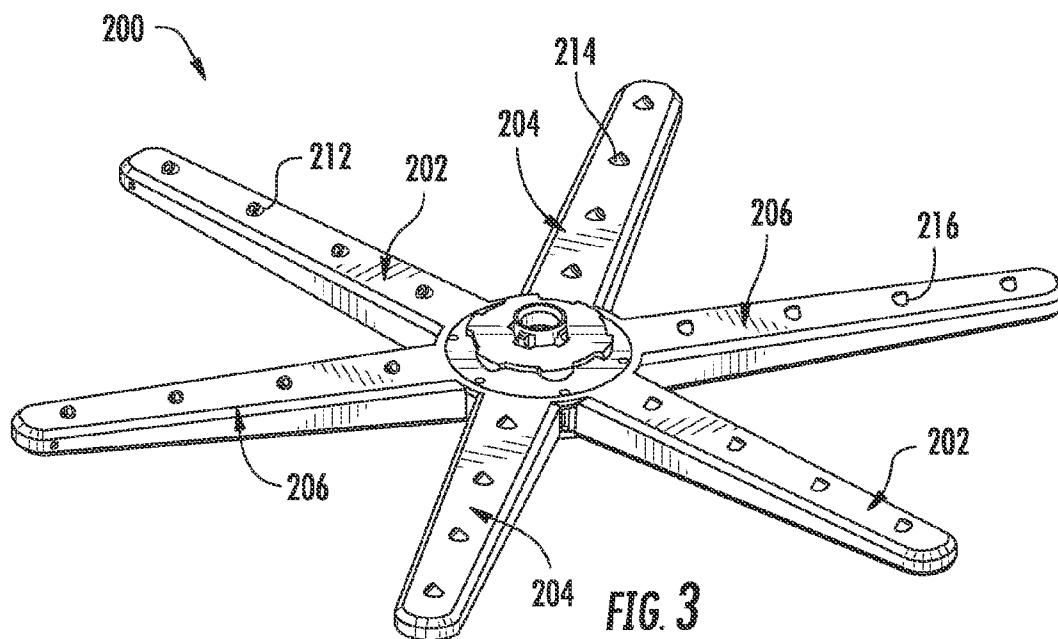
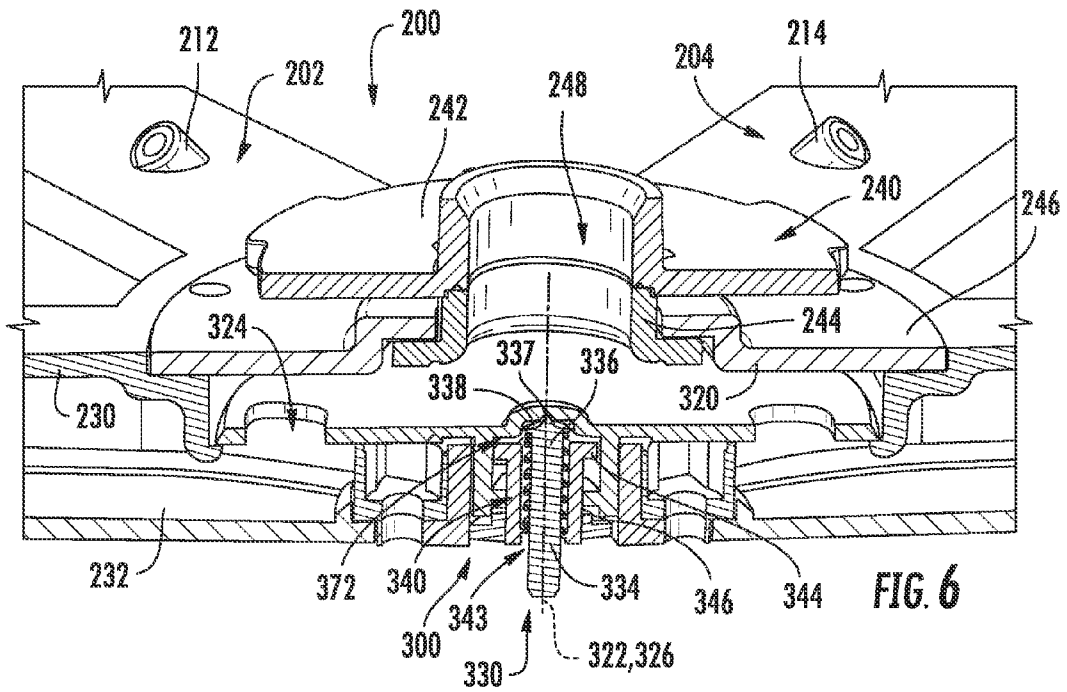
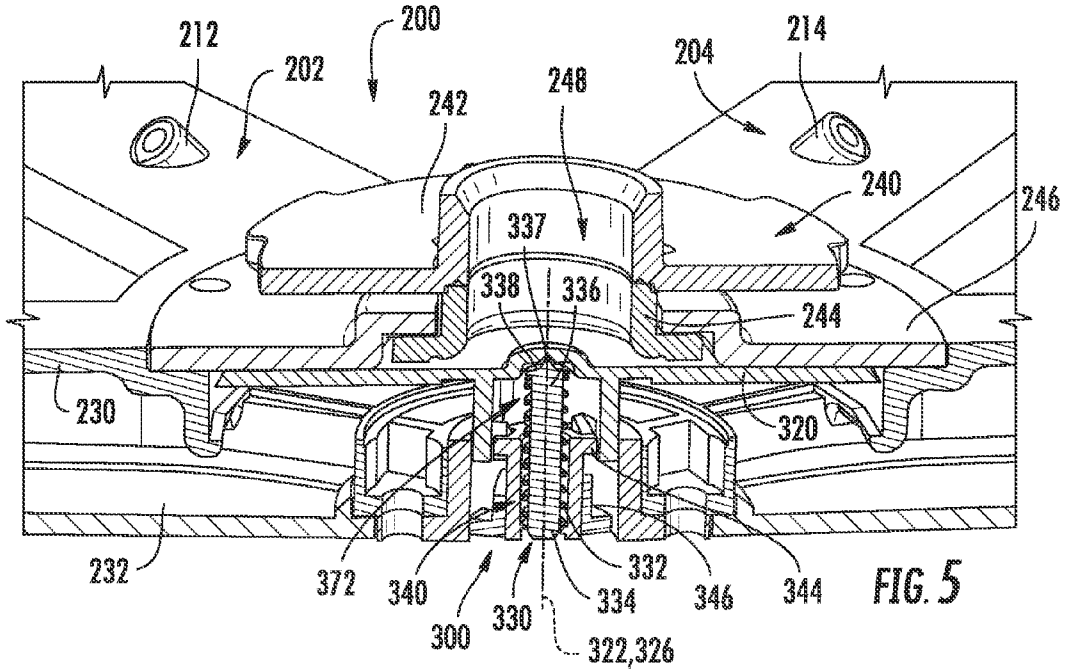
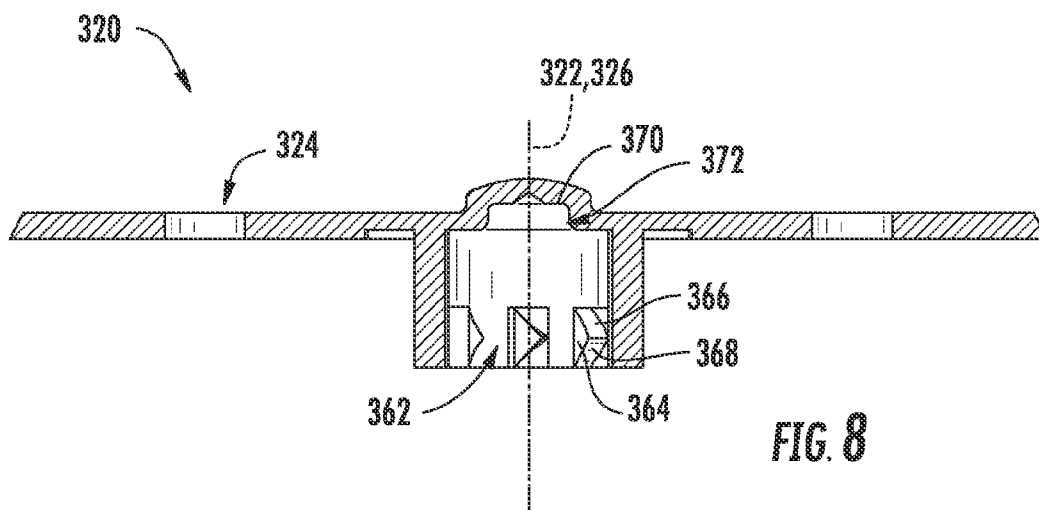
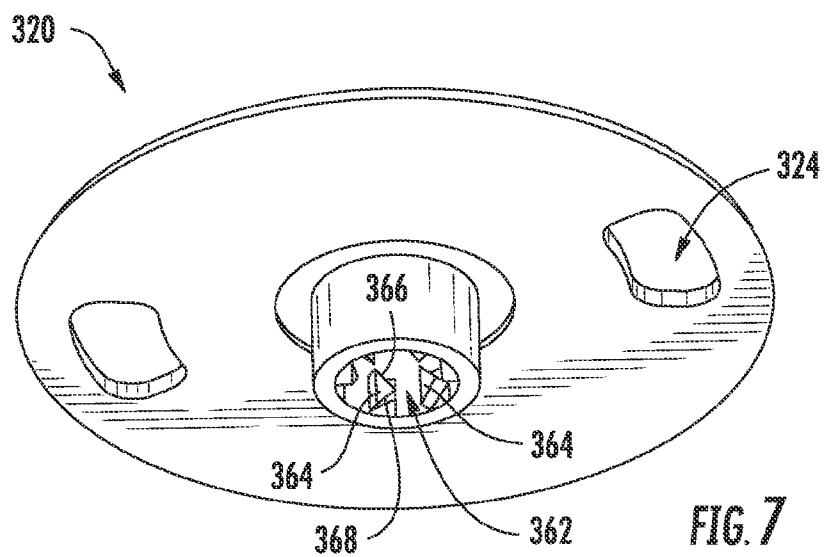
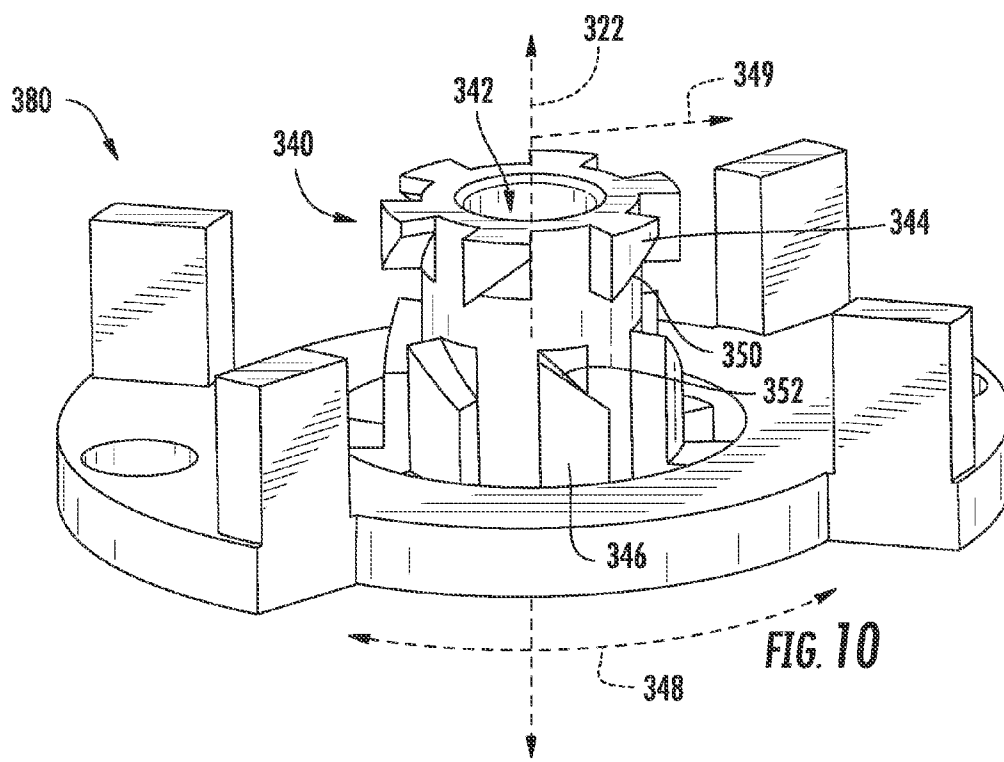
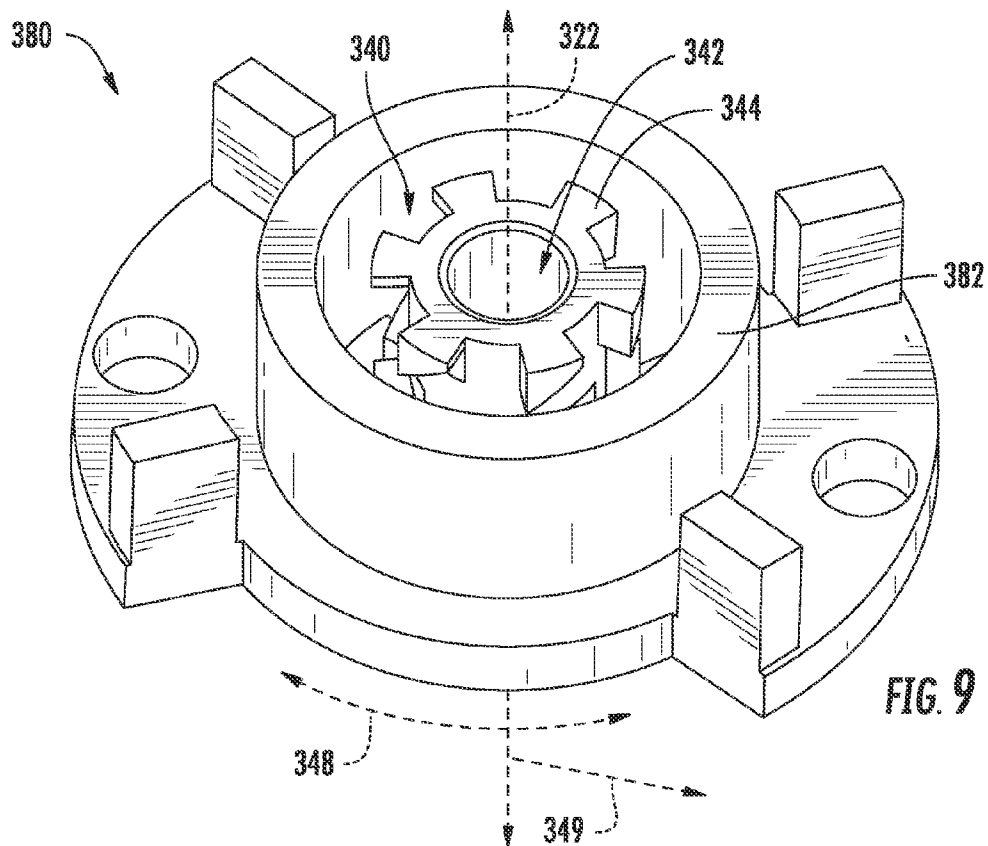

FIG. 2









SPRAY ARM ASSEMBLY FOR DISHWASHER APPLIANCES

FIELD OF THE INVENTION

[0001] The subject matter of the present disclosure relates generally to dishwasher appliances, and more particularly to spray arm assemblies in dishwasher assemblies which include improved indexing and reversing features.

BACKGROUND OF THE INVENTION

[0002] Dishwasher appliances generally include a tub that defines a wash compartment. Rack assemblies can be mounted within the wash compartment of the tub for receipt of articles for washing. Spray assemblies within the wash compartment can apply or direct wash fluid towards articles disposed within the rack assemblies in order to clean such articles. Multiple spray assemblies can be provided including e.g., a lower spray arm assembly mounted to the tub at a bottom of the wash compartment, a mid-level spray arm assembly mounted to one of the rack assemblies, and/or an upper spray assembly mounted to the tub at a top of the wash compartment. Other configurations may be used as well.

[0003] Recently, reversing features have been added to spray arms utilized in dishwasher appliances. These features allow the spray arms to spin in one direction for a period of time and then reverse direction, spinning in the opposite direction for a period of time. This can improve the performance of the dishwasher appliance by providing wash fluid which can contact articles in the dishwasher appliance at multiple directions and from multiple locations.

[0004] However, currently known reversing spray arms rely on costly and complicated reversing features. For example, various actively actuatable mechanical mechanisms have been utilized to facilitate reversing of the spray arms. Such currently known features and spray arms additionally are susceptible to leakage and pressure losses during operation.

[0005] Accordingly, improved spray arms for dishwasher appliances are desired. In particular, spray arms with improved reversing features, and which are less expensive and more reliable than currently known spray arms, would be advantageous.

BRIEF DESCRIPTION OF THE INVENTION

[0006] In one exemplary embodiment, the present disclosure provides a dishwasher appliance. The dishwasher appliance includes a tub that defines a wash chamber for receipt of articles for washing, and a spray arm assembly for directing a fluid flow into the wash chamber. The spray arm assembly includes a plurality of spray arms, the plurality of spray arms comprising a first spray arm and a second spray arm. The spray arm assembly further includes a conduit in fluid communication with the plurality of spray arms, and an indexing assembly disposed between the conduit and the plurality of spray arms, the indexing assembly operable to selectively flow fluid to the first spray arm and the second spray arm. The indexing assembly includes a disk rotatable about an axis and movable along an axial direction between a first position and a second position, the disk defining an aperture and a channel and comprising a plurality of cams projecting into the channel. The indexing assembly further includes a biasing element configured to urge the disk into the first position, and a boss assembly, the boss assembly comprising a boss extending

into the channel of the disk, the boss defining a plurality of guide elements. The guide elements and cams are configured to interact such that movement of the disk along the axial direction between the first position and the second position causes the disk to rotate about the axis.

[0007] In another exemplary embodiment, the present invention provides a spray arm assembly for a dishwasher appliance. The assembly includes a plurality of spray arms, the plurality of spray arms comprising a first spray arm and a second spray arm. The assembly further includes a conduit in fluid communication with the plurality of spray arms, and an indexing assembly disposed between the conduit and the plurality of spray arms, the indexing assembly operable to selectively flow fluid to the first spray arm and the second spray arm. The indexing assembly includes a disk rotatable about an axis and movable along an axial direction between a first position and a second position, the disk defining an aperture and a channel and comprising a plurality of cams projecting into the channel. The indexing assembly further includes a biasing element configured to urge the disk into the first position, and a boss assembly, the boss assembly comprising a boss extending into the channel of the disk, the boss defining a plurality of guide elements. The guide elements and cams are configured to interact such that movement of the disk along the axial direction between the first position and the second position causes the disk to rotate about the axis.

[0008] These and other features, aspects, and advantages of the present invention will become better understood with reference to the following description and appended claims. The accompanying drawings, which are incorporated in and constitute a part of this specification, illustrate embodiments of the invention and, together with the description, serve to explain the principles of the invention.

BRIEF DESCRIPTION OF THE DRAWINGS

[0009] A full and enabling disclosure of the present invention including the best mode thereof, directed to one of ordinary skill in the art, is set forth in the specification, which makes reference to the appended figures, in which:

[0010] FIG. 1 provides a front view of an exemplary embodiment of a dishwashing appliance of the present disclosure.

[0011] FIG. 2 provides a side, cross-sectional view of the exemplary dishwashing appliance of FIG. 1.

[0012] FIG. 3 is a perspective view of various components of a spray arm assembly in accordance with one embodiment of the present disclosure.

[0013] FIG. 4 is a perspective view of upper portions of a plurality of spray arms of a spray arm assembly in accordance with one embodiment of the present disclosure.

[0014] FIG. 5 is a cross-sectional view of various internal components of an exemplary embodiment of a spray arm assembly, including a disk in a first position, in accordance with one embodiment of the present disclosure.

[0015] FIG. 6 is a cross-sectional view of various internal components of an exemplary embodiment of a spray arm assembly, including a disk in a second position, in accordance with one embodiment of the present disclosure.

[0016] FIG. 7 is a perspective view of a disk of a spray arm assembly in accordance with one embodiment of the present disclosure.

[0017] FIG. 8 is a cross-sectional view of a disk of a spray arm assembly in accordance with one embodiment of the present disclosure.

[0018] FIG. 9 is a perspective view of a boss assembly of a spray arm assembly in accordance with one embodiment of the present disclosure.

[0019] FIG. 10 is a perspective view of a boss of a boss assembly, with an outer wall of the boss assembly not shown for illustrative purposes, of a spray arm assembly in accordance with one embodiment of the present disclosure.

DETAILED DESCRIPTION OF THE INVENTION

[0020] Reference now will be made in detail to embodiments of the invention, one or more examples of which are illustrated in the drawings. Each example is provided by way of explanation of the invention, not limitation of the invention. In fact, it will be apparent to those skilled in the art that various modifications and variations can be made in the present invention without departing from the scope or spirit of the invention. For instance, features illustrated or described as part of one embodiment can be used with another embodiment to yield a still further embodiment. Thus, it is intended that the present invention covers such modifications and variations as come within the scope of the appended claims and their equivalents.

[0021] As used herein, the term “article” may refer to, but need not be limited to, dishes, pots, pans, silverware, and other cooking utensils and items that can be cleaned in a dishwashing appliance. The term “wash cycle” is intended to refer to one or more periods of time during the cleaning process where a dishwashing appliance operates while containing articles to be washed and uses a detergent and water, preferably with agitation, to e.g., remove soil particles including food and other undesirable elements from the articles. The term “rinse cycle” is intended to refer to one or more periods of time during the cleaning process in which the dishwashing appliance operates to remove residual soil, detergents, and other undesirable elements that were retained by the articles after completion of the wash cycle. The term “drying cycle” is intended to refer to one or more periods of time in which the dishwashing appliance is operated to dry the articles by removing fluids from the wash chamber. The term “fluid” refers to a liquid used for washing and/or rinsing the articles and is typically made up of water that may include additives such as e.g., detergent or other treatments.

[0022] FIGS. 1 and 2 depict an exemplary domestic dishwasher 100 that may be configured in accordance with aspects of the present disclosure. For the particular embodiment of FIGS. 1 and 2, the dishwasher 100 includes a cabinet 102 having a tub 104 therein that defines a wash chamber 106. The tub 104 includes a front opening (not shown) and a door 120 hinged at its bottom 122 for movement between a normally closed vertical position (shown in FIGS. 1 and 2), wherein the wash chamber 106 is sealed shut for washing operation, and a horizontal open position for loading and unloading of articles from the dishwasher. A latch 123 may be used to lock and unlock door 120 for access to chamber 106.

[0023] Upper and lower guide rails 124, 126 are mounted on tub side walls 128 and accommodate roller-equipped rack assemblies 130 and 132. Each of the rack assemblies 130, 132 is fabricated into lattice structures including a plurality of elongated members 134 (for clarity of illustration, not all elongated members making up assemblies 130 and 132 are shown in FIG. 2). Each rack 130, 132 is adapted for movement between an extended loading position (not shown) in which the rack is substantially positioned outside the wash chamber 106, and a retracted position (shown in FIGS. 1 and

2) in which the rack is located inside the wash chamber 106. This is facilitated by rollers 135 and 139, for example, mounted onto racks 130 and 132, respectively. A silverware basket (not shown) may be removably attached to rack assembly 132 for placement of silverware, utensils, and the like, that are otherwise too small to be accommodated by the racks 130, 132.

[0024] The dishwasher 100 further includes a lower spray-arm assembly 144 that is rotatably mounted within a lower region 146 of the wash chamber 106 and above a tub sump portion 142 so as to rotate in relatively close proximity to rack assembly 132. A mid-level spray-arm assembly 148 is located in an upper region of the wash chamber 106 and may be located in close proximity to upper rack 130. Additionally, an upper spray assembly 150 may be located above the upper rack 130.

[0025] Each spray arm-assembly 144 may include a spray arm and a conduit in fluid communication with the spray arm, for providing a fluid flow to the spray arm. For example, mid-level spray-arm assembly 148 may include a spray arm 160 and a conduit 162. Lower spray-arm assembly 144 may include a spray arm 164 and a conduit 166. Additionally, upper spray assembly 150 may include a spray head 170 and a conduit 172 in fluid communication with the spray head 170.

[0026] The lower and mid-level spray-arm assemblies 144, 148 and the upper spray assembly 150 are part of a fluid circulation assembly 152 for circulating water and dishwasher fluid in the tub 104. The fluid circulation assembly 152 also includes a pump 154 positioned in a machinery compartment 140 located below the tub sump portion 142 (i.e., bottom wall) of the tub 104, as generally recognized in the art. Pump 154 receives fluid from sump 142 and provides a flow to the various assemblies 144, 148, 150.

[0027] Each spray-arm assembly 144, 148 includes an arrangement of discharge ports or orifices for directing washing liquid received from pump 154 onto dishes or other articles located in rack assemblies 130 and 132. The arrangement of the discharge ports in spray-arm assemblies 144, 148 provides a rotational force by virtue of washing fluid flowing through the discharge ports. The resultant rotation of the spray-arm assemblies 144, 148 and the operation of spray assembly 150 provides coverage of dishes and other dishwasher contents with a washing spray. Other configurations of spray assemblies may be used as well.

[0028] The dishwasher 100 is further equipped with a controller 137 to regulate operation of the dishwasher 100. The controller may include one or more memory devices and one or more microprocessors, such as general or special purpose microprocessors operable to execute programming instructions or micro-control code associated with a cleaning cycle. The memory may represent random access memory such as DRAM, or read only memory such as ROM or FLASH. In one embodiment, the processor executes programming instructions stored in memory. The memory may be a separate component from the processor or may be included onboard within the processor.

[0029] The controller 137 may be positioned in a variety of locations throughout dishwasher 100. In the illustrated embodiment, the controller 137 may be located within a control panel area 121 of door 120 as shown in FIGS. 1 and 2. In such an embodiment, input/output (“I/O”) signals may be routed between the control system and various operational components of dishwasher 100 along wiring harnesses that

may be routed through the bottom **122** of door **120**. Typically, the controller **137** includes a user interface panel/controls **136** through which a user may select various operational features and modes and monitor progress of the dishwasher **100**. In one embodiment, the user interface **136** may represent a general purpose I/O (“GPIO”) device or functional block. In one embodiment, the user interface **136** may include input components, such as one or more of a variety of electrical, mechanical or electro-mechanical input devices including rotary dials, push buttons, and touch pads. The user interface **136** may include a display component, such as a digital or analog display device designed to provide operational feedback to a user. The user interface **136** may be in communication with the controller **137** via one or more signal lines or shared communication busses.

[0030] It should be appreciated that the invention is not limited to any particular style, model, or configuration of dishwasher. The exemplary embodiment depicted in FIGS. **1** and **2** is for illustrative purposes only. For example, different locations may be provided for user interface **136**, different configurations may be provided for racks **130**, **132**, and other differences may be applied as well.

[0031] FIGS. **3** through **10** illustrate a spray arm assembly **200** and various components thereof in accordance with various embodiments of the present disclosure. As discussed, the assembly **200** is operable to direct a fluid flow into the wash chamber **106**, for example via a plurality of spray arms and a conduit. The conduit may be in fluid communication with the plurality of spray arms, and may thus supply the fluid flow to the spray arms. Fluid may be received from the fluid circulation assembly **152** by the conduit for flowing to the spray arms.

[0032] In some exemplary embodiments, the spray arm assembly **200** is a mid-level spray-arm assembly **148**. In these embodiments, the conduit may be conduit **162**. Alternatively, the spray arm assembly **200** may be a lower spray-arm assembly **144**. In these embodiments, the conduit may be conduit **166**. In still other embodiments, the spray arm assembly **200** may substitute for upper spray assembly **150**. In these embodiments, the conduit may be conduit **170**.

[0033] As illustrated, spray arm assembly **200** includes a plurality of spray arms. Any suitable number of spray arms may be included in spray arm assembly. For example, the plurality of spray arms of a spray arm assembly **200** may include one or more first spray arms **202**, one or more second spray arms **204**, and one or more third spray arms **206**. In the embodiment illustrated, the plurality of spray arms includes a pair of first spray arms **202**, a pair of second spray arms **204**, and a pair of third spray arms **206**. The spray arms of each pair are disposed oppositely in an array of spray arms.

[0034] Each spray arm **202**, **204**, **206** includes a plurality of discharge ports, through which fluid is flowed into the chamber **106**. For example, first spray arms **202** include discharge ports **212**, second spray arms **204** include discharge ports **214**, and third spray arms **206** include discharge ports **216**. The orientation of the discharge ports **212**, **214**, **216** may cause the plurality of spray arms to rotate in a certain direction when fluid is flowed through the discharge ports. For example, the first discharge ports **212** and third discharge ports **216** as illustrated are oriented such that the plurality of spray arms rotate clockwise when fluid is being flowed therethrough. Second discharge ports **214** as illustrated are oriented such that the plurality of spray arms rotate counter-clockwise when fluid is being flowed therethrough. Alternatively, first dis-

charge ports **212** and third discharge ports **216** may be oriented such that the plurality of spray arms rotate counter-clockwise when fluid is being flowed therethrough, and second discharge ports **214** may be oriented such that the plurality of spray arms rotate clockwise when fluid is being flowed therethrough. In still other embodiments, any suitable directional orientation for any discharge ports is within the scope and spirit of the present disclosure.

[0035] Each spray arm of the plurality of spray arms may define a channel through which fluid may flow to the discharge ports. For example, a first channel **222** may be defined in each first spray arm **202**, a second channel **224** may be defined in the second spray arm **204**, and a third channel **226** may be defined in the third spray arm **206**. As discussed herein, fluid may be selectively and sequentially flowed to channels **222**, **224** and **226** for flowing to ports **212**, **214**, **216** and from the ports into the wash chamber **106**. For example, as discussed herein indexing features may selectively flow fluid to channel **222** for a period of time. The indexing features may then index to selectively flow fluid to the second channels **224**, and then to the third channels **226**. Notably, when fluid is flowed to the first channels **222** and third channels **226** as illustrated, the plurality of spray arms may rotate in one direction, and when fluid is flowed to the second channels **224** as illustrated, the plurality of spray arms may rotate in an opposite direction.

[0036] The plurality of spray arms may in some embodiments be formed together from one or more components. FIG. **4** illustrates upper portions **230** of each spray arm, which may be formed integrally from a single component as illustrated or may be formed individually. Lower portions **232** of the spray arms **232** are illustrated in FIGS. **5** and **6**, and may similarly be formed integrally from a single component or formed individually. The upper portions **230** and lower portions **232** may be brought together to define the channels **222**, **224**, **226** therebetween.

[0037] Referring now to FIGS. **5** through **10**, various additional components of a spray arm assembly **200** are illustrated. For example, referring to FIGS. **5** and **6** (also illustrated in FIG. **3**), an inlet assembly **240** is illustrated. The inlet assembly **240** may be disposed between and in fluid communication with the conduit and the plurality of spray arms. Thus, fluid may flow from the conduit through the inlet assembly **240** to the plurality of spray arms. Inlet assembly **240** may include, for example, an outer cap **242** and an inner cap **244**. The outer cap **242** may connect to the conduit. A spray arm cover **246** may be disposed between the inner cap **244** and outer cap **242**, and may connect to the plurality of spray arms. The cover **246** may rotate with the plurality of spray arms between the inner cap **244** and outer cap **242**. Accordingly, a bearing may be disposed between the cover **246** and inner cap **244** to facilitate such rotation. As illustrated, a bore **248** may be defined by the inlet assembly **240**, such as by the various components thereof, through which fluid may flow to the plurality of spray arms.

[0038] It should be understood that the present disclosure is not limited to the above described inlet assembly **240**, and rather that any suitable inlet assembly for facilitating fluid flow from the conduit to plurality of spray arms and/or rotation of the plurality of spray arms is within the scope and spirit of the present disclosure. For example, portions or all of the inlet assembly **240** may be integral with the conduit and/or plurality of spray arms, or the inlet assembly **240** and com-

ponents thereof may be separate components from the conduit and/or plurality of spray arms.

[0039] Referring now to FIGS. 5 through 10, an indexing assembly 300 is provided for facilitating indexing within the spray arm assembly 200 and resulting selective flowing of fluid to the various spray arms. The indexing assembly 300 may be disposed between the inlet assembly 240 and the plurality of spray arms, and may be operable to selectively flow fluid to the plurality of spray arms, such as the first spray arms 202, second spray arms 204, and third spray arms 206. Advantageously, the indexing assembly 300 selectively controls the fluid flow into the various spray arms without the need for an additional motor or other active component. Further, use of indexing assemblies according to the present disclosure is relatively inexpensive and minimizes leakage and pressure loss concerns during operation.

[0040] Indexing assembly 300 may include, for example a disk 320 which is rotatable about an axis 322, such as a central axial axis which may extend longitudinally with respect to the disk 320. The disk defines one or more apertures 324 for selectively controlling fluid flow from the conduit and inlet assembly into one or more spray arms, such as first spray arms 202, second spray arms 204, and third spray arms 206. Disk 320 can, for example, be selectively rotated such that apertures 324 align with one of channels 222, channels 224 or channels 226 and fluid can be flowed through the apertures 324 into these channels.

[0041] Such selective switching of the aperture 324 may advantageously occur without use of a motor or other active component. For example, as can be seen by comparing FIGS. 5 and 6, disk 320 is movable along an axial direction 326 (such as along axis 322, which is parallel to the axial direction 326) between a first position shown in FIG. 5 and a second position shown in FIG. 6. In the first position shown in FIG. 5, disk 320 is spaced from and not aligned with any of channels 222, 224, 226. The disk 320 may further be in contact with the inlet assembly 240, such as with the spray arm cover 246, as illustrated, which may prevent fluid from flowing through the apertures 324. Cams (discussed herein) of the disk 320 may be between guide elements of a boss (discussed herein) that the disk 320 may interact with to facilitate rotation thereof. In the second position shown in FIG. 6, disk 320 may be proximate and aligned with one of channels 222, 224, 226, and the cams may be in contact with the guide elements. The disk 320 may have, due to cam—guide element interaction, rotated to align with one of the channels 222, 224, 226. Accordingly, in the second position, apertures 324 align with one of channels 222, channels 224 or channels 226 and fluid can be flowed through the apertures 324 into these channels and thus into the corresponding spray arms 202, 204, 206.

[0042] Movement of disk 320 back and forth between the first position shown in FIG. 5 and the second position shown in FIG. 6 is provided by two opposing forces: i) the fluid flow passing through the conduit and inlet assembly 240 towards indexing assembly 300 that is counteracted by ii) a biasing element 330, which may include a compression spring 332 as shown. More particularly, biasing element 330 in exemplary embodiments urges the disk 320 into the first position. For example, when fluid is not flowing through conduit and inlet assembly 240 towards indexing assembly 300, biasing element 330 pushes along axial direction 326 against disk 320 and forces it away from channels 222, 224, 226 along axis 322 to the position shown in FIG. 5. Conversely, when there is a sufficient flow of fluid through conduit and inlet assembly

240 towards indexing assembly 300, the momentum of this fluid will impact disk 320. This momentum overcomes the force provided by biasing element 330 so as to shift disk 320 along axial direction 326 towards the channels 222, 224, 226 to a second position such as that shown in FIG. 6. Disk 320 will remain in the second position until the fluid flow ends or drops below a certain level. Then, biasing element 330 urges disk 320 along axial direction 326 back into the first position shown in FIG. 5.

[0043] The movement of disk 320 back and forth along axis 322 between the first and second positions shown in FIGS. 5 and 6 also causes disk 320 to rotate about axis 322 so that aperture 324 is switched to be in fluid communication with the various channels 222, 224, 226. For this exemplary embodiment, a single movement in either direction causes disk 320 to rotate approximately 30 degrees. Accordingly, disk 320 rotates about axis 322 approximately 60 degrees each time it is moved out of, and then returned to, either the first position (FIG. 5) or the second position (FIG. 6).

[0044] As shown in FIGS. 5 through 10, for this exemplary embodiment, channels 222, 224, 226 are generally spaced apart along a circumferential direction at angles of approximately 60 degrees. Thus, the rotation of disk 320 by approximately 60 degrees necessarily rotates apertures 324 so as to selectively provide fluid flow from one channel to the next channel along the direction of rotation.

[0045] As further illustrated, a cylindrically-shaped boss 340 extends along axis 322. As shown, when in the second position, the boss 340 may extend into a channel 362 defined by disk 320. Boss 340 may further define a recess 342 into which a first end of biasing element 330 is received. An opening 343 within recess 342 may additionally be defined, through which components of biasing element 330 may extend, as discussed herein. Boss 340 may also include a plurality of guide elements 344, 346 that are spaced apart from each other along a circumferential direction 348. The guide elements 344, 346 may project from the boss 340, such as in a radial direction 349. A first plurality of guide elements 344 are located near a distal end of boss 340 while a second plurality of guide elements 346 are located near the channels 222, 224, 226 relative to the first elements 344. Guide elements 344 and 346 are spaced apart along axial direction 326 and are also offset from each other along circumferential direction 348. More particularly, each of the second plurality of guide elements 346 is aligned with a gap positioned between a respective pair of the first plurality of guide elements 344. Conversely, each of the first plurality of guide elements 344 is aligned with a gap between a respective pair of the second plurality of guide elements 346.

[0046] Each of the guide elements 344 and 346 includes a contact face 350 and 352, respectively. Each face 350 and 352 may be at, for example, a non-zero angle between zero and 90 degrees from the axial direction 326. For the exemplary embodiment shown, this angle is about 45 degrees. In another embodiment, this angle is about 42 degrees. In still another embodiment, this angle is between about 40 degrees to about 50 degrees from the axial direction 326. It should be understood, however, that the present disclosure is not limited to the above disclosed angles, and rather that any suitable angles or combination of angles is within the scope and spirit of the present disclosure.

[0047] As stated and shown, boss 340 is received into a channel 362 formed and defined by disk 320. Disk 320 may further include a plurality of cams 364 projecting along the

radial direction 349 into channel 362. Each cam 364 includes an upper contact face 366 and a lower contact face 368. Each face 366 and 368 may, similar to contact faces 350, 352, be at, for example, a non-zero angle between zero and 90 degrees from the axial direction 326. A depression 370 of disk 320 defined and disposed in channel 362 may form and define a second recess 372 into which a second end of biasing element 330 is received.

[0048] Guide elements 344, 346 and cams 364 are configured to interact so that movement of the disk 320 along the axial direction 326 between the first position and the second position causes the disk 320 to rotate about the axis 322. Thus, for example, as a flow of fluid overcomes biasing element 330 and disk 320 moves from the first position towards the second position, lower contact face 368 of each cam 364 contacts contact face 352 of a guide element 346. Disk 320 is caused to rotate, such as approximately 30 degrees, so that each cam 364 moves into a gap between a pair of the plurality of guide elements 346. This movement is guided by contact face 368 and contact face 352. In this second position, apertures 324 are aligned with one of channels 222, 224, 226. As the flow of fluid is turned off, biasing element 330 causes disk 320 to move towards the first position. During this movement, upper contact face 366 of each cam 364 contacts contact face 350 of a guide element 344 and causes disk 320 to rotate another approximately 30 degrees so that each cam 364 moves into a gap between a pair of the first plurality of guide elements 344. This movement is guided by contact face 366 and contact face 350. Upon returning to the second position, disk 320 is again caused to rotate by approximately 30 degrees as previously described so that apertures 330 are now switched to the next sequential channels. The process can be repeated to switch to still other sequential channels.

[0049] Accordingly, during operation of appliance 100, controller 137 can be programmed to operate pump 154 to flow fluid into the spray arm assembly 200 and thus control the position of disk 320. For example, knowing the last channel 222, 224, 226 through which fluid flow occurred, controller 137 can activate pump 154 to rotate disk 320 to the next channel in the direction of rotation of disk 320 so as to control the flow of fluid. Each time pump 154 is cycled off and back on to provide a flow of fluid through spray arm assembly 200, the controller 137 will “know” that disk 320 has been rotated to the next channel.

[0050] Boss 340 may be a component of a boss assembly 380 which may be included in indexing assembly 300. The boss assembly 380 may include the boss 340 and an outer wall 382, which may be a generally cylindrical wall spaced from and surrounding the boss 340. The portion of the disk 320 defining the channel 262 may be disposed between the boss 340 and the outer wall 382.

[0051] Referring briefly again to FIGS. 5 and 6, biasing element 330 as discussed may include a spring 332, such as a compression spring as illustrated. In some embodiments, biasing element 330 may further include a needle bearing 334 which the spring 332 may generally surround. The needle bearing 334 may facilitate rotation of the disk 320 and operation of the indexing assembly 300, by preventing the spring 332 from impeding such rotation and the operation of the indexing assembly 300. For example, needle bearing 324 may include a shaft 336, a needle tip 337, and a collar 338. The tip 337 may contact the disk 320, such as within the second recess 372. The collar 338 may be an upper barrier of the bearing 324 past which the spring 332 cannot extend, such

that the spring 332 does not directly contact the disk 320. Additionally, the end of the shaft 336 opposite the needle tip 337 may be allowed to extend through the opening 343 defined in the first recess 343 when the disk 320 is in the second position. Accordingly, when the disk 320 rotates, the needle bearing 334 may rotate with the disk 320 and relative to the spring 332. The spring may indirectly interact with the disk 320 during movement between the first position and the second position. The use of the needle bearing 334 such that the disk 320 rotates relative to the spring 332, however, reduces or prevents the spring 332 from torqueing during disk 320 rotation and then inducing a biasing force on the disk 320 in the opposite rotational direction, impeding operation of the indexing assembly 300.

[0052] As stated, the indexing assembly 300 of the present disclosure may be used with more or less than three channels or pluralities of channels. In such case, as will be understood by one of skill in the art using the teachings disclosed herein, the configuration of cams and guide elements described above can be modified to provide the desired amount of rotation between the selected number of channels. Six cams along with six upper and six lower guide elements are used to provide approximately 60 degrees of rotation between six channels in the exemplary embodiment above described. By way of example, four cams along with four upper and four lower guide elements could be used to provide approximately 90 degrees of rotation between four outlet ports and so forth. [0053] This written description uses examples to disclose the invention, including the best mode, and also to enable any person skilled in the art to practice the invention, including making and using any devices or systems and performing any incorporated methods. The patentable scope of the invention is defined by the claims, and may include other examples that occur to those skilled in the art. Such other examples are intended to be within the scope of the claims if they include structural elements that do not differ from the literal language of the claims or if they include equivalent structural elements with insubstantial differences from the literal language of the claims.

What is claimed is:

1. A dishwasher appliance, comprising:
 - a tub that defines a wash chamber for receipt of articles for washing;
 - a spray arm assembly for directing a fluid flow into the wash chamber, the spray arm assembly comprising:
 - a plurality of spray arms, the plurality of spray arms comprising a first spray arm and a second spray arm;
 - a conduit in fluid communication with the plurality of spray arms;
 - an indexing assembly disposed between the conduit and the plurality of spray arms, the indexing assembly operable to selectively flow fluid to the first spray arm and the second spray arm, the indexing assembly comprising:
 - a disk rotatable about an axis and movable along an axial direction between a first position and a second position, the disk defining an aperture and a channel and comprising a plurality of cams projecting into the channel;
 - a biasing element configured to urge the disk into the first position; and
 - a boss assembly, the boss assembly comprising a boss extending into the channel of the disk, the boss defining a plurality of guide elements, wherein the

guide elements and cams are configured to interact such that movement of the disk along the axial direction between the first position and the second position causes the disk to rotate about the axis.

2. The dishwasher appliance of claim 1, wherein the disk is movable into the second position by fluid flowed through the inlet assembly and into contact with the disk.

3. The dishwasher appliance of claim 1, wherein the aperture is aligned to flow fluid to one of the plurality of spray arms when the disc is in the second position.

4. The dishwasher appliance of claim 1, wherein the boss defines a first recess into which a first end of the biasing element is received.

5. The dishwasher appliance of claim 1, wherein the disk defines a second recess within the channel, and wherein a second end of the biasing element is received into the second recess.

6. The dishwasher appliance of claim 1, wherein the boss is cylindrically-shaped and defines a circumferential direction and a radial direction, wherein the guide elements of the boss project along the radial direction and are spaced apart from each other along the circumferential direction.

7. The dishwasher appliance of claim 6, wherein the guide elements each include a contact face positioned at a non-zero angle from the axial direction.

8. The dishwasher appliance of claim 1, further comprising an inlet assembly disposed between and in fluid communication with the conduit and the plurality of spray arms.

9. The dishwasher appliance of claim 1, wherein the biasing element comprises a needle bearing and a spring, the spring generally surrounding the needle bearing.

10. The dishwasher appliance of claim 1, wherein the disk comprises a plurality of apertures and the plurality of spray arms comprises a plurality of first spray arms and a plurality of second spray arms.

11. A spray arm assembly for a dishwasher appliance, comprising:

a plurality of spray arms, the plurality of spray arms comprising a first spray arm and a second spray arm;

a conduit in fluid communication with the plurality of spray arms;

an indexing assembly disposed between the conduit and the plurality of spray arms, the indexing assembly operable to selectively flow fluid to the first spray arm and the second spray arm, the indexing assembly comprising:

a disk rotatable about an axis and movable along an axial direction between a first position and a second position, the disk defining an aperture and a channel and comprising a plurality of cams projecting into the channel;

a biasing element configured to urge the disk into the first position; and

a boss assembly comprising a boss extending into the channel of the disk, the boss defining a plurality of guide elements, wherein the guide elements and cams are configured to interact such that movement of the disk along the axial direction between the first position and the second position causes the disk to rotate about the axis.

12. The spray arm assembly of claim 11, wherein the disk is movable into the second position by fluid flowed through the inlet assembly and into contact with the disk.

13. The spray arm assembly of claim 11, wherein the aperture is aligned to flow fluid to one of the plurality of spray arms when the disc is in the second position.

14. The spray arm assembly of claim 11, wherein the boss defines a first recess into which a first end of the biasing element is received.

15. The spray arm assembly of claim 11, wherein the disk defines a second recess within the channel, and wherein a second end of the biasing element is received into the second recess.

16. The spray arm assembly of claim 11, wherein the boss is cylindrically-shaped and defines a circumferential direction and a radial direction, wherein the guide elements of the boss project along the radial direction and are spaced apart from each other along the circumferential direction.

17. The spray arm assembly of claim 16, wherein the guide elements each include a contact face positioned at a non-zero angle from the axial direction.

18. The spray arm assembly of claim 11, further comprising an inlet assembly disposed between and in fluid communication with the conduit and the plurality of spray arms.

19. The spray arm assembly of claim 11, wherein the biasing element comprises a needle bearing and a spring, the spring generally surrounding the needle bearing.

20. The spray arm assembly of claim 11, wherein the disk comprises a plurality of apertures and the plurality of spray arms comprises a plurality of first spray arms and a plurality of second spray arms.

* * * * *