



(12) **EUROPEAN PATENT APPLICATION**

(43) Date of publication:  
**16.02.2005 Bulletin 2005/07**

(51) Int Cl.7: **D06F 35/00, D06F 39/08,  
D06F 39/00**

(21) Application number: **04002021.6**

(22) Date of filing: **30.01.2004**

(84) Designated Contracting States:  
**AT BE BG CH CY CZ DE DK EE ES FI FR GB GR  
HU IE IT LI LU MC NL PT RO SE SI SK TR**  
Designated Extension States:  
**AL LT LV MK**

- **Kim, Jin-Woong**  
**Gwangmyeong, Gyeonggi-Do (KR)**
- **Oh, Soo-Young**  
**Yangcheon-Gu, Seoul (KR)**
- **Jeon, Si-Moon**  
**Seoul (KR)**

(30) Priority: **13.08.2003 KR 2003056266**

(74) Representative: **COHAUSZ & FLORACK**  
**Patent- und Rechtsanwälte**  
**Bleichstrasse 14**  
**40211 Düsseldorf (DE)**

(71) Applicant: **LG ELECTRONICS INC.**  
**Seoul (KR)**

(72) Inventors:  
• **Woo, Kyung-Chul**  
**Yangcheon-Gu, Seoul (KR)**

(54) **Method for smoothing wrinkles of laundry in washing machine**

(57) A method for smoothing the laundry wrinkled during a washing process in the washing machine is disclosed. When a command signal for smoothing wrinkles of the laundry in the washing machine is inputted, water supplied in the washing machine is heated to generate steam and then the generated steam is injected to the laundry in the washing machine while rotating a drum of the washing machine. Thus, wrinkles of the laundry can be smoothed in the washing machine without causing a trouble of ironing.

FIG. 4

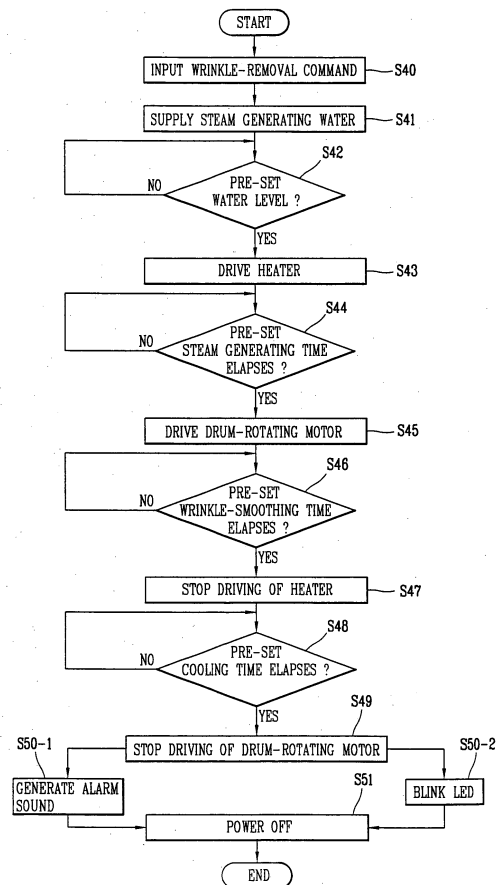

**Description**

## BACKGROUND OF THE INVENTION

## 1. Field of the Invention

**[0001]** The present invention relates to a washing machine and, more particularly, to a method for smoothing wrinkles of the laundry in a drum-type washing machine.

## 2. Description of the Background Art

**[0002]** In general, a washing machine is a device for washing the laundry by performing a washing, rinsing and dewatering stroke. The washing machine is divided into several types according to a washing method such as a pulsator method, an agitation method, a drum method, and the like.

**[0003]** A general drum-type washing machine will now be described with reference to Figure 1. Figure 1 is a sectional view showing a general drum-type washing machine.

**[0004]** As shown in Figure 1, the drum-type washing machine 1 includes a drum 4 having a plurality of lifts 5 formed therein in order to wash the laundry; a rotational shaft 3 coupled to the drum 4 to rotate the drum 4; a motor 6 for transferring a rotational force to the rotational shaft 3 through a pulley; a tub 2 supporting the rotational shaft 3 and coupled at an outer side of the drum 4 to store water; and a heater 7 installed at a lower side of the tub 2 and heating water.

**[0005]** The general drum-type washing machine is operated as follows.

**[0006]** First, after a user inputs the laundry into the drum 4 of the drum-type washing machine 4 and depresses a start button, water is supplied to the drum 4 and at the same time power is applied to the motor 6. At this time, a rotational force of the motor 6 reaches the rotational shaft 3 by a motor system by means of the pulley and a belt, and thus, the rotational shaft 3 is rotated owing to the rotational force of the motor 6. That is, as the drum 4 is repeatedly rotated forwardly and backwardly by virtue of the rotational shaft 3, the laundry in the drum 4 is washed. In addition, washing is also performed by impact power generated when the laundry is lifted up and dropped down by means of the plurality of lifts 5 formed inside the drum 4 and extension and contraction.

**[0007]** According to the drum-type washing method, after a detergent, water and the laundry are input to the drum, washing is performed by using a frictional force between the drum 4 rotated upon receiving the rotational force of the motor 6 and the laundry, so that the laundry is not hardly damaged nor tangled, and in addition, a washing effect of pounding and rubbing the laundry can be obtained.

**[0008]** Other conventional drum-type washing machines are disclosed in USP Nos. 6,615,619 and

6,612,138.

**[0009]** However, the conventional drum-type washing machine has a problem that when a series of washing stroke is completed, the laundry in the drum-type washing machine is found to have wrinkles. For example, when the washing machine completes the washing process, the rinsing process and the dewatering process, the laundry in the drum-type washing machine wrinkles. Thus, after taking the wrinkled laundry out of the washing machine, a user should iron the laundry to get smoothed.

## SUMMARY OF THE INVENTION

**[0010]** Therefore, an object of the present invention is to provide a method for smoothing of the laundry wrinkled during a washing process in a washing machine without causing a trouble of ironing after completion of washing.

**[0011]** To achieve these and other advantages and in accordance with the purpose of the present invention, as embodied and broadly described herein, there is provided a method for smoothing wrinkles of the laundry in a washing machine including: heating water supplied into a washing machine and generating steam when a command signal for smoothing wrinkles of the laundry in the washing machine is inputted; and injecting the generated steam to the laundry in the washing machine while rotating a drum of the washing machine.

**[0012]** To achieve the above object, there is also provided a method for smoothing wrinkles of the laundry in a washing machine including: supplying water into a steam generator of a washing machine when a command signal for smoothing wrinkles of the laundry is inputted by a user's request after a washing process of the washing machine is completed; heating water by means of a heater installed in the steam generator to generate steam; injecting steam generated for a first pre-set time to the laundry in the drum while rotating the drum of the washing machine; and stopping steam-injecting when the first pre-set time elapses.

**[0013]** The foregoing and other objects, features, aspects and advantages of the present invention will become more apparent from the following detailed description of the present invention when taken in conjunction with the accompanying drawings.

## BRIEF DESCRIPTION OF THE DRAWINGS

**[0014]** The accompanying drawings, which are included to provide a further understanding of the invention and are incorporated in and constitute a part of this specification, illustrate embodiments of the invention and together with the description serve to explain the principles of the invention.

**[0015]** In the drawings:

Figure 1 is a sectional view showing a general

drum-type washing machine;

Figure 2 is a perspective view showing a drum-type washing machine having a steam generator in accordance with the present invention;

Figure 3 is a view showing a process of smoothing the laundry adopted for Figure 2 in accordance with the present invention; and

Figure 4 is a flow chart of a method for smoothing wrinkles of the laundry in the drum-type washing machine in accordance with the present invention.

#### DETAILED DESCRIPTION OF THE PREFERRED EMBODIMENTS

**[0016]** Reference will now be made in detail to the preferred embodiments of the present invention, examples of which are illustrated in the accompanying drawings.

**[0017]** A preferred embodiment of a method for smoothing the laundry wrinkled during a washing process in the drum-type washing machine, without causing a trouble of ironing the laundry afterward, by heating water supplied into the washing machine to generate steam and injecting the generated steam to the laundry in the washing machine while rotating the drum of the washing machine, will now be described with reference to Figures 2 to 4.

**[0018]** As shown in Figure 2, a drum-type washing machine having a steam generator of the present invention includes: a drum 140 rotated by a rotational force of an internal motor (reference numeral 210 in Figure 3) of a washing machine to wash the laundry; a water supply pipe 100 for supplying water into the drum 140; a detergent box 190 for supplying a detergent into the drum 140; a steam generator 110 for supplying steam into the drum 140; an injection nozzle 130 for injecting steam generated from the steam generator 110 into the drum 140 through a back-current preventing basin device 120; a drain pipe 150 for draining water from the drum 140; a circulation pump 160 for pumping water drained from the drain pipe 150 and circulating it to the back-current preventing basin device 120 through a cyclic water pipe 170; and an outer cabinet 180 for protecting the drum 140, the water supply pipe 100, the detergent box 190, the steam generator 110, the injection nozzle 130, the drain pipe 150 and the circulation pump 160.

**[0019]** The drum-type washing machine in accordance with the present invention is operated as follows.

**[0020]** First, after a washing process, a rinsing process and a dewatering process are completed, when a user depresses a button (not shown) for smoothing wrinkles of the laundry, steam generating water is supplied into the steam generator 110.

**[0021]** When steam generating water is supplied as much as a pre-set water level in the steam generator 110, water supply is stopped and a heater (not shown) in the steam generator 110 is operated. That is, the heater converts steam generating water supplied into the

steam generator 110 into steam.

**[0022]** Thereafter, when steam in the steam storage space of the steam generator 110 is collected to go beyond a predetermined pressure, steam is injected into the drum 140 of the washing machine through the injection nozzle 130. Then, the injected steam is in contact with the laundry in the drum 140, thereby smoothing wrinkles. Herein, to make steam be in contact with the laundry evenly, it is preferred that the drum is rotated for a pre-set wrinkle-smoothing time (e.g., two minutes) while steam is injected to the laundry.

**[0023]** After the operation for smoothing wrinkles of the laundry is completed, the drum 140 is rotated for a pre-set cooling time (e.g., one minute). When it reaches the pre-set cooling time, the drum is stopped from rotating to remove moisture generated as steam is in contact with the laundry.

**[0024]** Accordingly, after the washing process, wrinkles of the laundry can be smoothed in the washing machine without causing a trouble of ironing afterwards.

**[0025]** The process of smoothing wrinkles of the laundry of the present invention will now be described in detail with reference to Figure 3.

**[0026]** Figure 3 is a view showing a process of smoothing the laundry adopted for Figure 2 in accordance with the present invention.

**[0027]** First, when a command signal for smoothing wrinkles of the laundry is inputted by a user's request, a controller opens a water supply valve (not shown) and supplies steam generating water as much as a pre-set water level in the steam generator 110. The steam generator 110 communicates with the drum 140 accommodating the laundry, and a header (not shown) is installed inside the steam generator 110.

**[0028]** When the command signal for smoothing wrinkles of the laundry is inputted, the header is operated by a control signal of the controller to heat the steam generating water supplied in the steam generator 110 and generate steam.

**[0029]** Thereafter, when steam generated in the steam generator 110 reaches a pressure above a predetermined level, steam is injected to the laundry 200 in the drum 140 while the motor 210 communicating with the drum 140 is driven to rotate the drum 140 for a pre-set wrinkle-smoothing time, whereby the wrinkled laundry can be smoothed in the drum-type washing machine after completion of the washing without a necessity of ironing.

**[0030]** When the pre-set wrinkle-smoothing time is terminated, the heater in the steam generator is stopped to discontinue generation of steam and the drum 140 is rotated for a pre-set cooling time (e.g., one minute) to remove moisture remaining in the laundry. When the pre-set cooling time elapses, that is, when the time for smoothing wrinkles of the laundry is terminated, the user is informed accordingly.

**[0031]** The method for smoothing wrinkles of the laundry in the drum-type washing machine in accordance

with a preferred embodiment of the present invention will now be described with reference to Figure 4.

**[0032]** First, when the command signal for smoothing wrinkles of the laundry is inputted by a user's request (step S40), the controller opens the water supply valve according to the wrinkle-removing command signal and supplies steam generating water into the steam generator 110 (step S41).

**[0033]** While the steam generating water is supplied into the steam generator 110, a water level sensor (not shown) determines whether a water level of the steam generating water reaches a pre-set water level in the steam generator 110 (step S42). In this respect, preferably, the pre-set water level is set at an uppermost position of the heater of the steam generator 110.

**[0034]** Thereafter, when the water level of the steam generating water reaches the pre-set water level in the steam generator 110, the heater is driven (step S43) to generate steam. At this time, steam is generated for a pre-set steam generating time (e.g., two minutes ~ four minutes), and when the pre-set steam generating time elapses (step S44), the generated steam is injected to the laundry 200 in the drum.

**[0035]** While steam is injected to the laundry 200 inside the drum, the drum rotation motor 210 is driven (step S45) to rotate the drum with the laundry received therein. Accordingly, as the generated steam is injected to the laundry inside the drum and the drum is rotated according to driving of the drum-rotating motor, steam is in contact with the laundry evenly, whereby wrinkles of the laundry generated after completion of the washing process can be smoothed.

**[0036]** The process of injecting steam to the laundry and simultaneously rotating the drum 140 by driving the drum-rotating motor 210 is performed for the pre-set wrinkle-smoothing time (e.g., two minutes), and then, when the pre-set wrinkle-smoothing time elapses (step S46), the heater of the steam generator 110 is stopped to discontinue generation of steam (step S47).

**[0037]** After the heater of the steam generator 110 is stopped from operating (step S47), the drum is kept rotating for a pre-set cooling time (e.g., one minute) to cool the heat generated to the laundry as steam has been injected to the laundry. When the pre-set cooling time elapses (step S48), the drum-rotating motor 210 is stopped to stop rotation of the drum (step S49). Accordingly, by rotating the drum after injecting steam to the laundry to smooth wrinkles of the laundry, the wrinkles of the laundry is smoothed and the laundry is dewatered.

**[0038]** After the laundry is dewatered in the step S49, the user is informed of the completion of smoothing of wrinkles of the laundry (steps S50-1 and S50-2), power supply to the washing machine is automatically cut off (step S51), and the present invention is terminated. There can be diverse methods of informing the user of completion of the operation of smoothing wrinkles of the laundry. For example, preferably, an alarm sound can be generated (step S50-1) or an LED (Light Emitting Di-

ode) displaying that the process of smoothing wrinkles of the laundry is being performed can be blinked (step S50-2), to inform the user of completion of smoothing the wrinkles of the laundry.

**[0039]** As so far described, the method for smoothing wrinkles of the laundry in a drum-type washing machine in accordance with the present invention has the following advantage.

**[0040]** That is, for example, after the washing stroke is completed, the drum is rotated while steam is injected to the laundry positioned in the drum, whereby the laundry wrinkled during the washing process can be smoothed and thus the user may not be troubled by ironing the laundry.

**[0041]** As the present invention may be embodied in several forms without departing from the spirit or essential characteristics thereof, it should also be understood that the above-described embodiments are not limited by any of the details of the foregoing description, unless otherwise specified, but rather should be construed broadly within its spirit and scope as defined in the appended claims, and therefore all changes and modifications that fall within the metes and bounds of the claims, or equivalence of such metes and bounds are therefore intended to be embraced by the appended claims.

## Claims

1. A method for smoothing wrinkles of the laundry in a washing machine comprising:

heating water supplied into a washing machine and generating steam when a command signal for smoothing wrinkles of the laundry in the washing machine is inputted; and injecting the generated steam to the laundry in the washing machine while rotating a drum of the washing machine.

2. The method of claim 1, wherein the step of injecting steam to the laundry in the washing machine comprises:

terminating injection of steam to the laundry in the washing machine when a first pre-set time elapses, and rotating the drum for a second pre-set time.

3. The method of claim 2, wherein the step of injecting steam to the laundry in the washing machine comprises:

stopping rotation of the drum when the second pre-set time elapses, and informing a user of completion of smoothing wrinkles of the laundry.

4. The method of claim 3, wherein, in the step of injecting steam to the laundry in the washing machine, an alarm sound is generated or an LED (Light Emitting Diode) displaying proceeding of a process of smoothing wrinkles of the laundry is blinked in order to inform the user of completion of smoothing wrinkles of the laundry. 5
5. A method for smoothing wrinkles of the laundry in a washing machine comprising: 10
- supplying water into a steam generator of a washing machine when a command signal for smoothing wrinkles of the laundry is inputted by a user's request after a washing process of the washing machine is completed; 15
- heating water by means of a heater installed in the steam generator to generate steam; 20
- injecting steam generated for a first pre-set time to the laundry in the drum while rotating the drum of the washing machine; and 25
- stopping steam-injecting when the first pre-set time elapses.
6. The method of claim 5, wherein the step of injecting steam to the laundry comprises: 25
- rotating the drum for a second pre-set time after terminating injection of steam to the laundry in the washing machine. 30
7. The method of claim 6, wherein the step of injecting steam to the laundry in the washing machine comprises: 35
- stopping rotation of the drum when the second pre-set time elapses, and informing a user of completion of smoothing wrinkles of the laundry. 40
8. The method of claim 7, wherein, in the step of injecting steam to the laundry in the washing machine, an alarm sound is generated or an LED (Light Emitting Diode) displaying proceeding of a process of smoothing wrinkles of the laundry is blinked in order to inform the user of completion of smoothing wrinkles of the laundry. 45
9. A method for smoothing wrinkles of the laundry in a drum-type washing machine comprising: 50
- supplying water into a steam generator of a drum-type washing machine when a command signal for smoothing wrinkles of the laundry is inputted by a user's request after a washing process of the drum-type washing machine is completed; 55
- heating water by means of a heater installed in the steam generator to generate steam; 60
- injecting steam generated for a first pre-set time to the laundry in the drum while rotating the drum of the drum-type washing machine; 65
- stopping steam-injecting when the first pre-set time elapses; 70
- rotating the drum for a second pre-set time after stopping injection of steam to the laundry in the drum-type washing machine; and 75
- stopping rotation of the drum when the second pre-set time elapses and informing a user of completion of smoothing wrinkles of the laundry. 80
10. The method of claim 9, wherein in the step of injecting steam to the laundry in the washing machine, an alarm sound is generated or an LED (Light Emitting Diode) displaying proceeding of a process of smoothing wrinkles of the laundry is blinked in order to inform the user of completion of smoothing wrinkles of the laundry. 85

FIG. 1

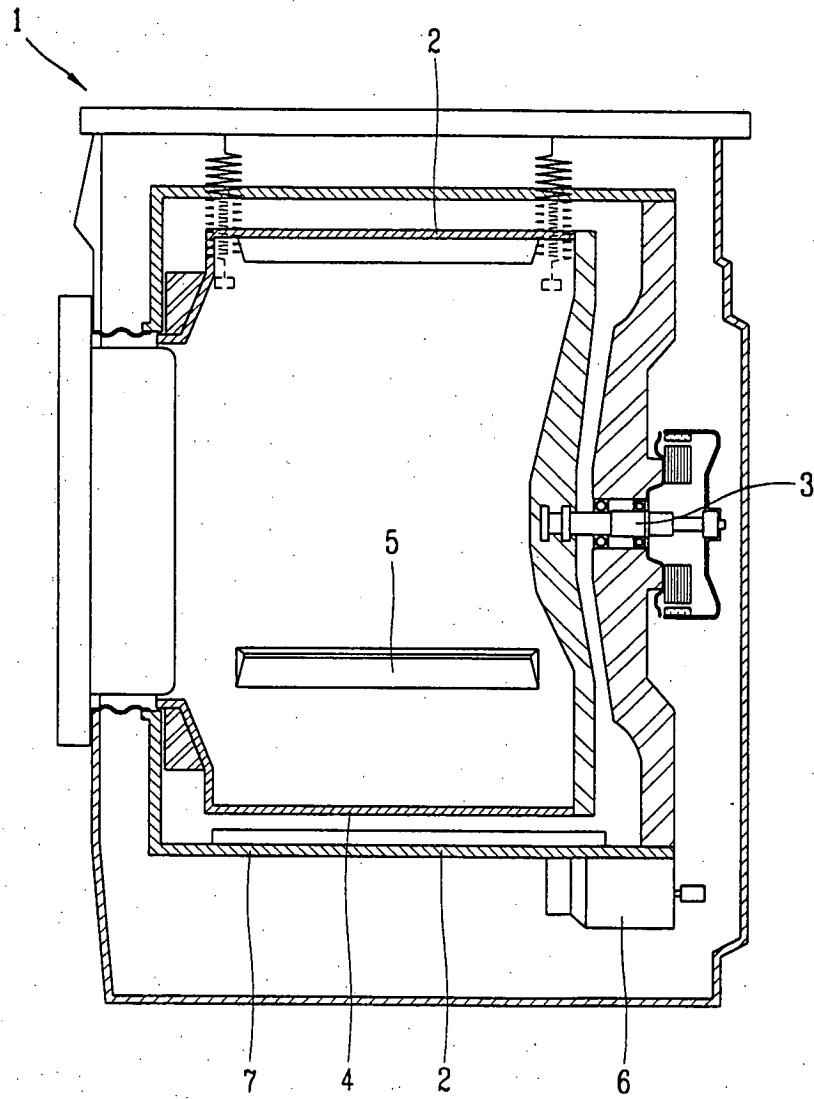

FIG. 2

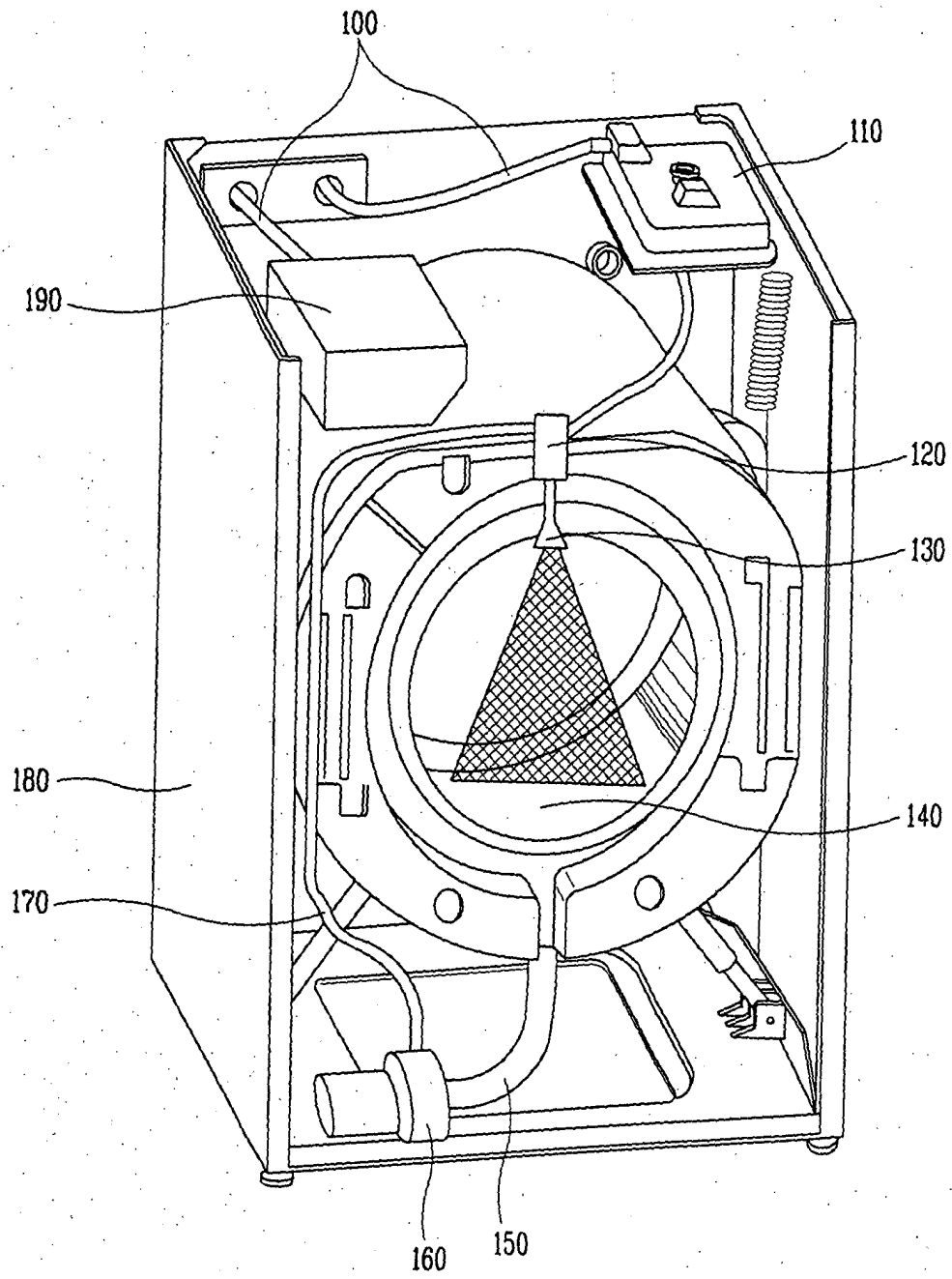

FIG. 3

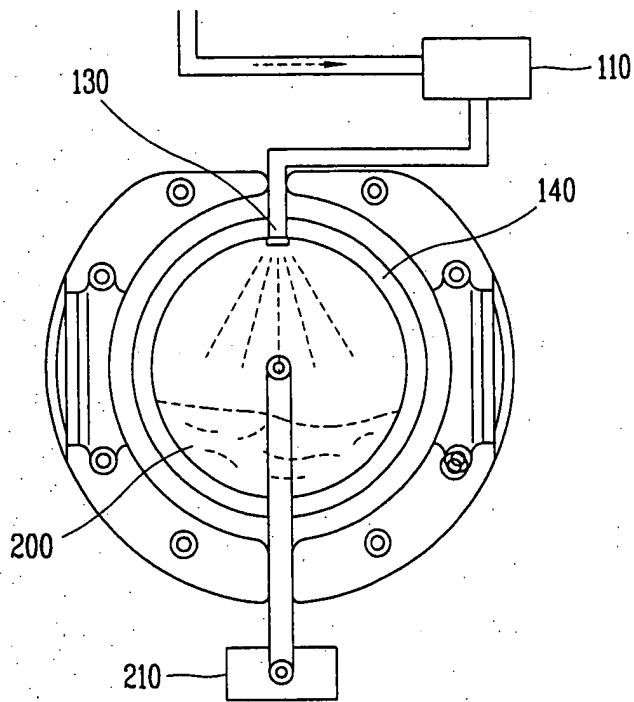
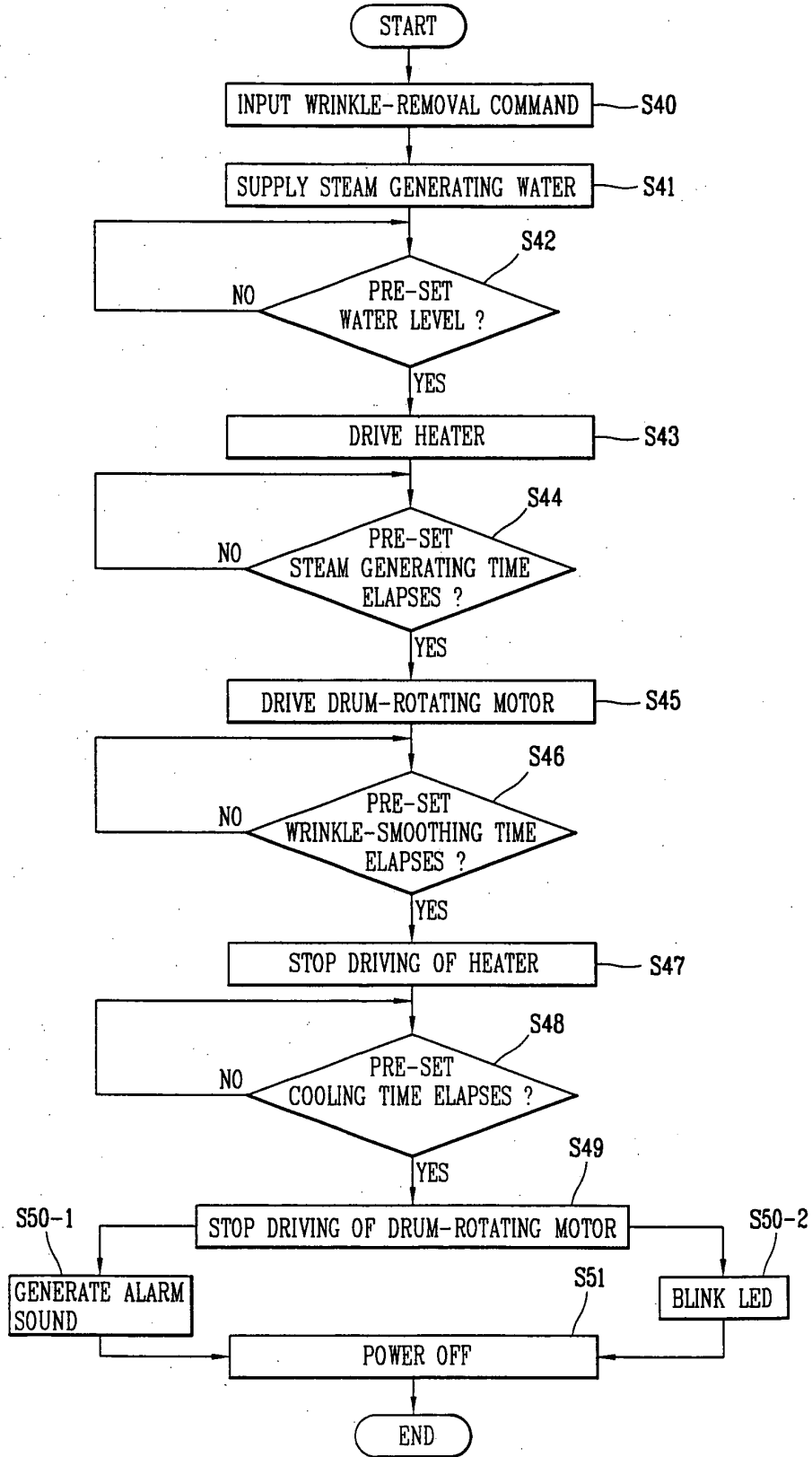



FIG. 4





European Patent  
Office

EUROPEAN SEARCH REPORT

Application Number  
EP 04 00 2021

DOCUMENTS CONSIDERED TO BE RELEVANT			
Category	Citation of document with indication, where appropriate, of relevant passages	Relevant to claim	CLASSIFICATION OF THE APPLICATION (Int.Cl.7)
X	EP 1 275 767 A (V ZUG AG) 15 January 2003 (2003-01-15) * the whole document *	1-10	D06F35/00 D06F39/08 D06F39/00
A	PATENT ABSTRACTS OF JAPAN vol. 2003, no. 05, 12 May 2003 (2003-05-12) -& JP 2003 019382 A (MITSUBISHI ELECTRIC CORP), 21 January 2003 (2003-01-21) * abstract *	1-10	
E	US 2004/187527 A1 (KIM JIN WOONG ET AL) 30 September 2004 (2004-09-30) * the whole document *	1-10	
			TECHNICAL FIELDS SEARCHED (Int.Cl.7)
			D06F
The present search report has been drawn up for all claims			
Place of search Munich		Date of completion of the search 27 October 2004	Examiner Spitzer, B
<p>CATEGORY OF CITED DOCUMENTS</p> <p>X : particularly relevant if taken alone                      Y : particularly relevant if combined with another document of the same category                      A : technological background                      O : non-written disclosure                      P : intermediate document</p> <p>T : theory or principle underlying the invention                      E : earlier patent document, but published on, or after the filing date                      D : document cited in the application                      L : document cited for other reasons</p> <p>&amp; : member of the same patent family, corresponding document</p>			

EPO FORM 1503 03/82 (P04001)

**ANNEX TO THE EUROPEAN SEARCH REPORT  
ON EUROPEAN PATENT APPLICATION NO.**

EP 04 00 2021

This annex lists the patent family members relating to the patent documents cited in the above-mentioned European search report. The members are as contained in the European Patent Office EDP file on  
The European Patent Office is in no way liable for these particulars which are merely given for the purpose of information.

27-10-2004

Patent document cited in search report		Publication date	Patent family member(s)	Publication date
EP 1275767	A	15-01-2003	EP 1275767 A1	15-01-2003
JP 2003019382	A	21-01-2003	NONE	
US 2004187527	A1	30-09-2004	EP 1464751 A1	06-10-2004

EPO FORM P0459

For more details about this annex : see Official Journal of the European Patent Office, No. 12/82