

T. NORDENFELT.
BREECH MECHANISM FOR GUNS.

No. 384,537.

Patented June 12, 1888.

Fig. 1.

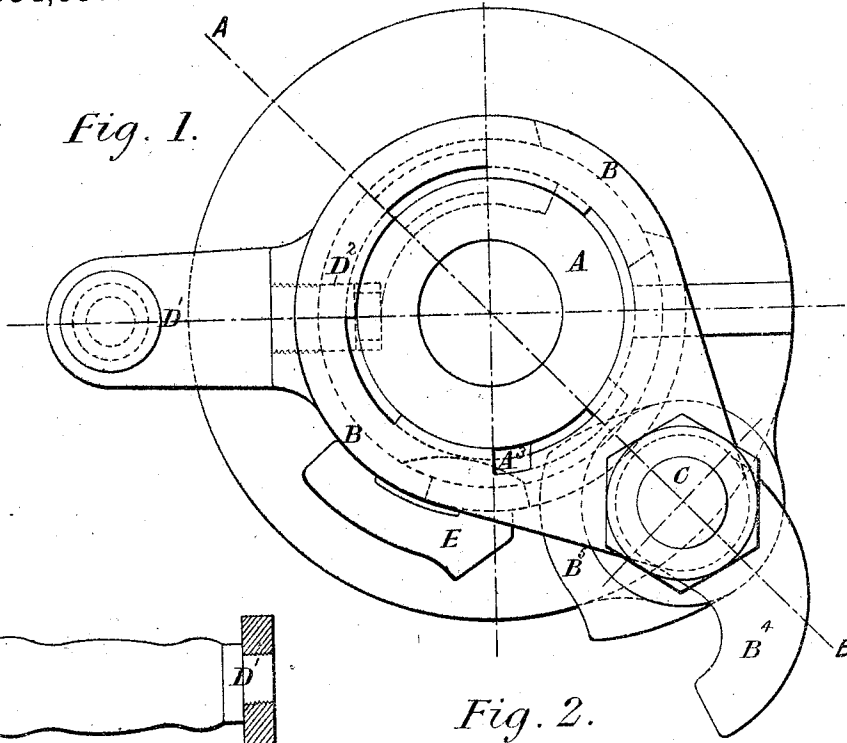
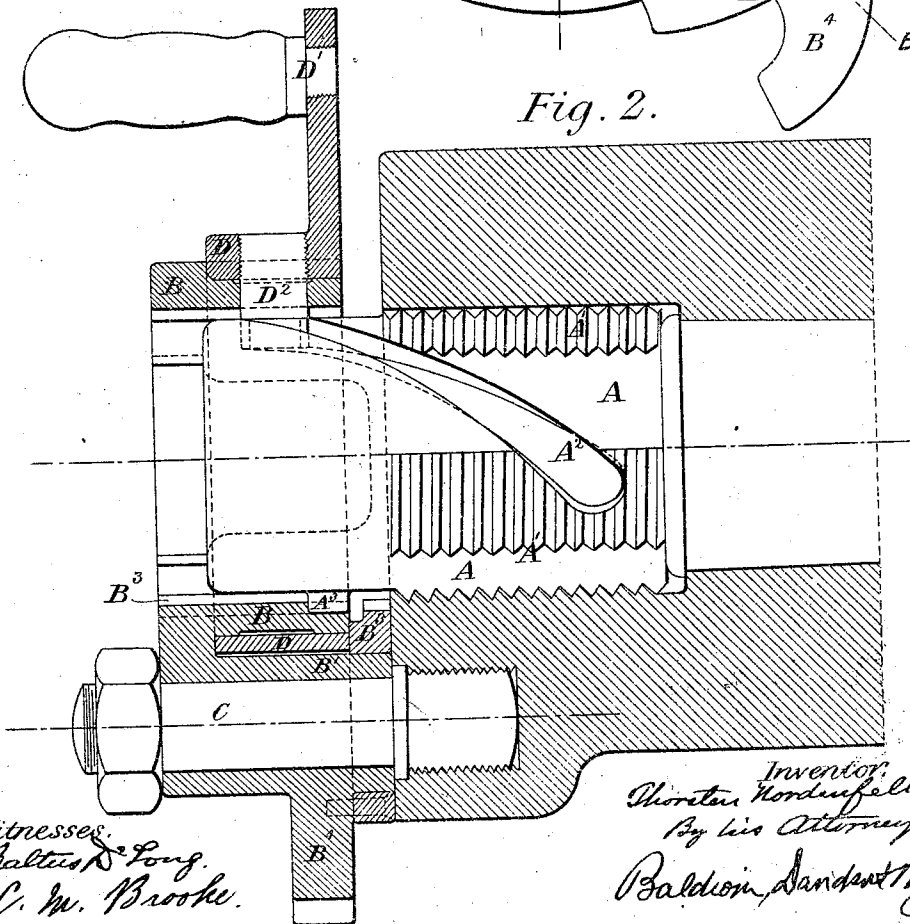

Fig. 2.



Witnesses:
Baltus Long.
C. W. Brooke.

Inventor:
Thorsten Nordenfelt.
By his Attorneys,
Baldwin, Sanderson & Light.

T. NORDENFELT.

BREECH MECHANISM FOR GUNS.

No. 384,537.

Patented June 12, 1888.

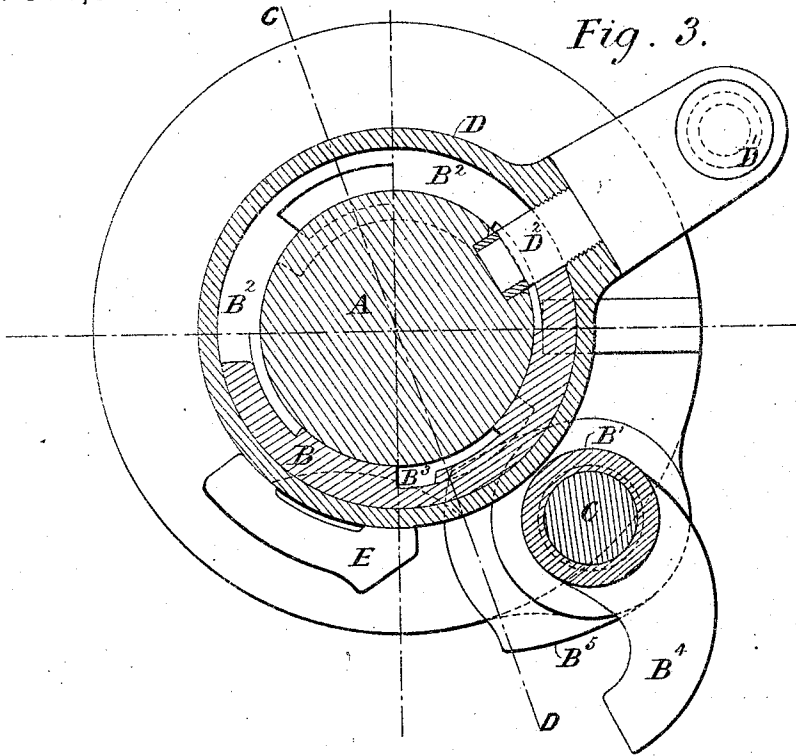

Fig. 3.

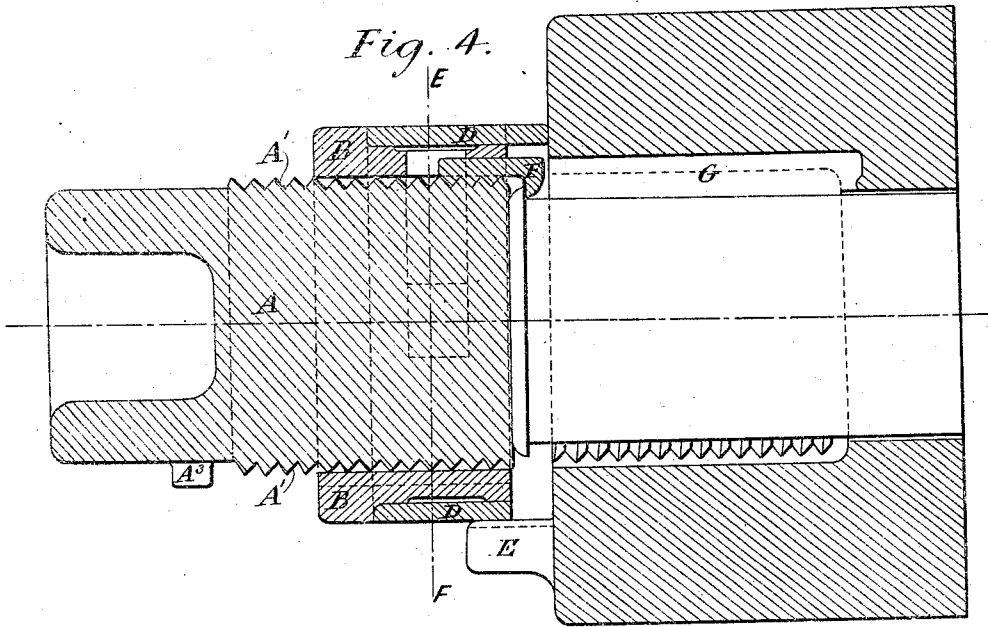

Fig. 4.

Witnesses:
Baltus DeLong.
C. W. Brocke.

Inventor:
Thorsten Nordenfält.
 By his Attorneys:
Baldwin, Dredman & Knight.

(No Model.)

6 Sheets—Sheet 3.

T. NORDENFELT.
BREECH MECHANISM FOR GUNS.

No. 384,537.

Patented June 12, 1888.

Fig. 5.

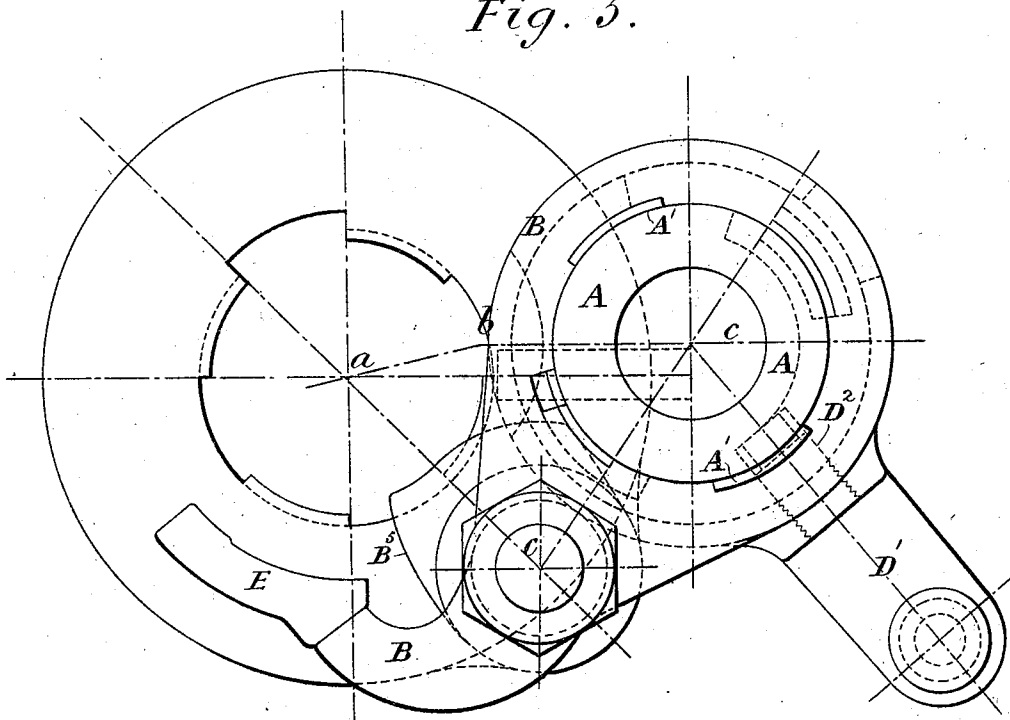
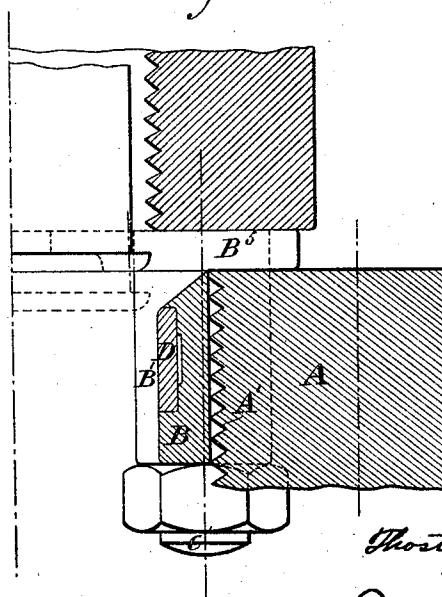

Fig. 6.



Witnesses.
Baltus De Long,
C. W. Brooke.

Inventor.
Thosten Nordenfelt.
By his Attorneys.
Baldwin, Davidson & Nigh

(No Model.)

6 Sheets—Sheet 5.

T. NORDENFELT.

BREECH MECHANISM FOR GUNS.

No. 384,537.

Patented June 12, 1888.

Fig. 8.

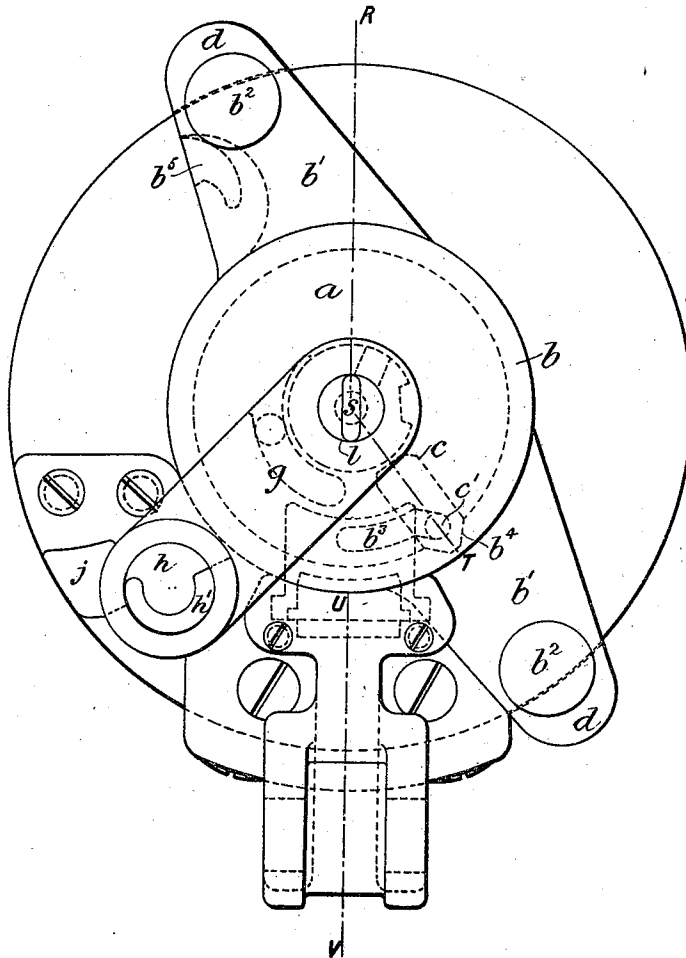

Witnesses.

Baltus D. Long.
C. M. Brooke.

Inventor.

Thorsten Nordenfält.
By his Attorneys.

Baldwin, Dandson & Nyket.

(No Model.)

6 Sheets—Sheet 6.

T. NORDENFELT.

BREECH MECHANISM FOR GUNS.

No. 384,537.

Patented June 12, 1888.

Fig. 9

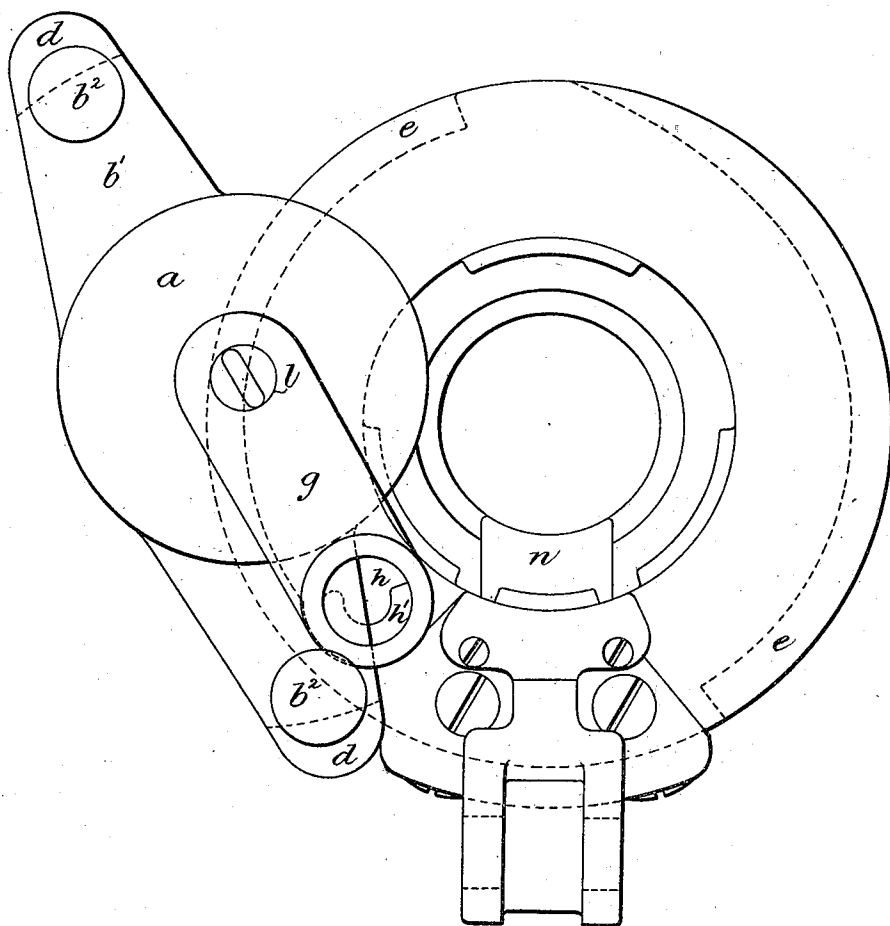

Witnesses,

Baltus De Long.

C. M. Brooke.

Inventor,

Thorsten Nordenfält.

By his Attorneys.

Baldwin, Lindsen & Night.

UNITED STATES PATENT OFFICE.

THORSTEN NORDENFELT, OF WESTMINSTER, ENGLAND, ASSIGNOR TO THE NORDENFELT GUNS AND AMMUNITION COMPANY, (LIMITED,) OF SAME PLACE.

BREECH MECHANISM FOR GUNS.

SPECIFICATION forming part of Letters Patent No. 384,537, dated June 12, 1888.

Application filed April 2, 1888. Serial No. 269,315. (No model.)

To all whom it may concern:

Be it known that I, THORSTEN NORDENFELT, a subject of the King of Sweden, residing at 53 Parliament Street, in the city of Westminster, England, civil engineer, have invented certain new and useful Improvements in Breech Mechanisms for Guns, of which the following is a specification.

My improvements relate to that class of breech mechanism in which the breech of a gun is closed by a block having segments of a screw-thread on its sides to lock into corresponding segments within the interior of the breech, so that to open the breech the screw-block has first to have a partial turn given to it, and then to be drawn backward.

According to my invention I, by means of one turning movement of a lever-handle which forms part of the movable breech-piece, give to such screw-block first a turning movement to disengage the screw-threads, then a backward movement to draw it back clear of the breech, and then carry it to one side to leave a clear opening into the breech end of the bore. The way in which I prefer to effect this is shown at Figs. 1, 2, 3, 4, 5, and 6 of the drawings hereunto annexed. A modified construction is shown at Figs. 7, 8, and 9.

Figure 1 is a back view of the gun with the breech closed. Fig. 2 is a longitudinal section on the line A B, Fig. 1. Fig. 3 is a cross-section on the line E F after the second part of the opening movement. Fig. 4 is a longitudinal section on the line C D. Fig. 5 is a back view of the gun with the breech open, and Fig. 6 is a section on the line *a b c*: Fig. 7 is a longitudinal section of the modified construction. The section is taken on the line R S T U V, Fig. 8. Fig. 8 is a back view with the breech closed and locked, and Fig. 9 is a back view with the breech open ready to receive a fresh cartridge.

In Figs. 1, 2, 3, 4, 5, and 6, A is a screw breech-piece; A', the segments of screw-thread on its sides to lock into corresponding screw-segments in the breech end of the gun. The breech-piece A extends backward beyond the rear end of the gun and enters loosely into a carrier-ring, B. This ring has a short arm 50 extending from it, and a boss, B', at the end

of the arm can be turned about a pin, C, which projects backward from the rear end of the breech of the gun.

D is a ring embracing and free to turn around the front end of the carrier-ring. 55

D' is a lever-handle extending from the ring D, by which the ring can be turned.

D² is a pin projecting inward from the ring and passing through a slot, B², in the carrier-ring into a helicoidal groove, A², in the screw breech-piece A. 60

A³ is a lug projecting from the screw breech-piece. It enters a slot cut out from the front end of the carrier-ring, and serves as a stop to prevent the breech-piece being turned too far. 65 It can also be drawn backward along a longitudinal slot, B³, on the inside of the carrier-ring when the screw breech-piece has been turned into a position to unlock it from the screw-segments in the gun. The interior of the carrier-ring is cut away in segments corresponding to the screw-segments of the breech-piece, so that when the breech-piece has been unlocked it may be drawn backward into it. 70

B⁴ is an arm extending from the boss B' of the arm which carries the carrier-ring. When the boss is turned around the pin C, it comes against a fixed projection, E, on the breech end of the gun, and the extent to which it can be turned is thereby limited. 75 80

B⁵ is a stop-plate fixed to the front end of the boss, B, and which, when the breech-piece has been drawn back and an empty cartridge-case with it, comes in front of the flange of the cartridge as soon as the carrier is turned to one side, and prevents the empty cartridge-case from being pushed back into the gun. The extractor is formed of a slide, F, having a hook at its front end to hook over the rim at the rear end of the cartridge-case and capable of being moved along a slot, G, in the gun, which is a deepening of one of the grooves cut away between the segments of screw-threads in the gun. On the inner face of the slide are teeth to engage with the screw-threads on the screw-breech-piece. 85 90 95

The action of the mechanism is as follows: To open the breech, the ring D has a partial turn given to it by its lever-handle D'. The pin D², which is then at one end of the helicoidal 100

groove, A^2 , tends either to turn the screw-breech A or to draw it back; but as the screw-threads upon the screw breech-piece are interlocking with the screw-threads in the gun it cannot be drawn back, and therefore it is turned until the screw-segments upon its side are disengaged from the corresponding screw-segments in the gun. The lug A^3 then comes to the end of the slot, cut away from the front end of the carrier-ring, and comes opposite to the end of the longitudinal slot B^3 in the ring. Therefore, as the outer ring, D , continues to be turned, and as the screw-breech is now prevented from turning, but free to be drawn back, it is drawn back into the carrier-ring. When the lug A^3 by the backward movement of the breech-piece has passed out from the rear end of the carrier-ring, the screw breech-piece is still prevented from turning by reason of the screw-segments upon it lying in corresponding grooves formed longitudinally on the inside of the carrier-ring. When the pin arrives at the end of the helicoidal groove in the screw breech-piece, and the screw breech-piece consequently cannot be drawn back any farther, its front end has been drawn back from the bore of the gun and the extractor, which comes back with it, has also been drawn back clear of the gun; and as the turning movement of the handle D' is continued, the carrier-ring, being now no longer restrained from being turned around the pin C , is turned around this pin and carries the breech-piece to one side, leaving the rear end of the gun open. The arm B^3 then comes against the fixed stop E , which prevents all further movement of the carrier-ring. The extractor on the commencement of the opening of the breech is first drawn back slowly a short distance by the action of the screw-threads on the breech-piece, and consequently has great power to start back the cartridge-case. When the breech-piece is drawn backward, (the teeth on the extractor being still interlocked with the screw-segment on the breech-piece,) the extractor is drawn back with it and carried back into a groove in the carrier-ring, as shown at Fig. 4. Immediately after it has been drawn back into this position and the carrier-ring is turned to one side the stop-plate B^5 , fixed on the boss, comes in front of the flange of the extracted cartridge-case. The cartridge-case is then removed by hand and a fresh one inserted in its place, the stop-plate B^5 preventing this cartridge from being inserted too far and arresting it in proper position for the front end of the breech-piece to come into position in rear of it and the hook of the extractor to come in front of the rim on its base when the breech is being again closed. The edge of the carrier-ring which first comes against the rear end of the cartridge-case at the time when the breech is being closed may be somewhat beveled off, so that should the cartridge have rebounded somewhat from the stop-plate B^5 , or not have been pushed home to it, this beveled edge may push the cartridge forward up to the stop-plate and allow the

breech-screw to be brought into position behind it. The closing of the breech is effected by turning the handle D' in the opposite direction to that required for opening it.

I will now describe the modified construction shown at Figs. 7, 8, and 9. In this modification, in place of the groove A^2 on the exterior of the screw breech-piece there is a groove on the exterior of the gun to effect the same object. In other respects, also, the construction is modified.

In Figs. 7, 8, and 9, a is the screw breech-piece. b is a ring capable of turning around its rear end.

b' are radial arms extending from it, and provided with handles b^2 , by which the ring can be turned.

c is a radial bolt, by which the screw and ring are at times locked together. It lies in a radial recess in the part a . Its outer end is V-shaped and enters a corresponding notch, b^1 , in the ring b . When the bolt is restrained from moving inward, the screw and ring are locked together; but when the bolt is moved inward the screw is unlocked from the ring, so that the ring can turn around the screw without the screw being turned.

d are arms extending forward from the radial arms b' along two opposite sides of the breech end of the gun.

d' are rollers at their ends, which enter grooves e , formed in the sides of the gun. The central part of this groove is, as shown by dotted lines in Fig. 1, made inclined to the bore.

f is a pin or axis upon which the breech-piece a turns. It is fixed to an arm, g , which can turn upon and also slide back along a fixed stud, h , which projects from the rear end of the gun. The rear extremity, h' , of the stud h is made to the form of a segment of a ring which is concentric with the stud.

b^5 is a groove in the front face of one of the radial arms, which passes onto and embraces this segment end after the screw breech-piece has been unlocked and drawn back. So soon as the groove b^5 engages with the annular segment h' , the ring b turns around the stud h until the screw a is supported by the stop j , which stands out from the rear end of the breech of the gun. The parts are then in the position shown in Fig. 3.

In opening the breech the screw a and ring b are at first locked together by the radial bolt c , as the inner end of the bolt then abuts against the axis f . Consequently when the ring is turned both the ring and the screw turn together until the inner end of the bolt c comes opposite to and is made to enter a recess in the axis f , and is thereby disengaged from the ring, leaving the ring free to continue turning without turning the screw. The endwise movement is given to the bolt by a pin, c' , upon it, which enters the inclined end of a slot, b^3 , in the ring. The incline of the slot is therefore always tending to press the bolt inward. As the ring continues its turning move-

ment, the rollers *d* at the extremity of the arms *d* now enter the parts of the groove *e*, which are inclined to the central line of the bore, and the screw is drawn back until the rollers 5 come into the end portions of the grooves, which are not inclined. The radial arm *b'* then engages with the stud *h*, and a pin, *i*, on the ring having now been brought to the end of a slot in the arm *g*, the ring *b*, with its arms *b'* 10 and arm *g*, all turn around the stud *h* as a fulcrum, and the breech-screw is carried to one side of the rear end of the breech and left resting upon the support *j*. When the lever is turned back in the opposite direction, the 15 movements are reversed and the breech is closed. The lock mechanism is contained within the pin *f*, on which the breech-screw *a* turns. The arrangements for setting back the hammer or striker to its "cocked" position 20 are as follows:

k is the hammer or striker thrown forward by the spring *k'*.

l is the trigger in a line with and in rear of it. This trigger is also pressed forward by a 25 spring, *l'*. When pressed forward by the spring, it has also a partial rotation given to it by a pin, *l''*, fixed to the axis *f*, entering an inclined groove formed around its circumference. In its front end is a recess, *l'''*, into which 30 the rear end of the stem of the striker can be made to enter when it is brought into a line with it. When a turning movement is given to the breech-screw to unlock it, an incline, *a'*, on the breech-screw, acting upon a lug, *k''*, projecting from the hammer, forces the hammer 35 back, and then gives to it a partial turn. A lug projecting from the hammer is thereby brought in rear of a stop, *m*, carried by the axis *f* and the hammer is held back. As the 40 hammer is being pressed back, as above mentioned, it presses back the trigger also, and as the trigger is moved back it also has a partial turn given to it in the manner above mentioned, and at the end of its backward 45 movement the slot *l''* in its front end is brought into such a position that the rear end of the stem of the hammer can enter into it, and when the hammer has a partial turn given to it at the end of its backward movement the 50 trigger-block, being pressed forward by its spring, turns with it and passes onto the rear end of the stem. To release the hammer, the trigger-block has to be pulled backward by a cord. When drawn back, it turns the hammer 55 in the opposite direction to that above mentioned, and so sets it free to be thrown forward by its spring.

n is the extractor. It slides in a longitudinal groove in the rear end of the gun. It carries a tooth, *n'*, with which one of the screw-threads of the breech-screw engages when the breech screw is turned. When the screw is 60 turned to open the breech, a slight backward movement is thereby given to the extractor, and the empty cartridge-case is started back 65 from the rear end of the bore of the gun. When the breech-screw is drawn back, the ex-

tractor carries the cartridge-case backward along with it. When at the end of the backward movement of the breech-screw, the 70 breech-screw is turned to one side, the threads of the screw become disengaged from the tooth *n'* of the extractor.

When a new cartridge is placed into the gun, its flange carries the extractor forward 75 along with it. When the breech-screw has been moved forward to close the breech and has a partial turn given to it to lock it, the cartridge is pressed home and carries the extractor along with it. One of the screw- 80 threads of the breech-screw also engages with the tooth *n'* of the extractor and presses it forward. In order that it may at this time be free to move forward, the tooth is carried by a small slide, *n''*, which is free to move to 85 and fro along the extractor-stem, but is pressed backward by a spring, *n'''*. When the screw has been turned to its locked position, the screw-thread becomes disengaged from the tooth *n'*, and the spring *n'''* presses the slide *n''* back 90 against part of the extractor-stem, so that when the breech-screw is again turned to open the breech and the screw again engages with the tooth *n'* the extractor is at once drawn 95 back by it.

What I claim is—

1. Breech mechanism for guns having a screw breech-piece with divided segments of screw-threads upon it, corresponding segments in the gun for these segments to lock into, a 100 ring capable of being turned around the rear end of such breech-piece, a lever-handle extending from the ring by which it can be turned, a pin or pins carried by the ring to enter inclined grooves, so disposed that when the ring 105 is turned by its lever-handle it first gives a partial turn to the breech-piece to unlock it, and then draws the breech-piece back clear of the rear end of the gun, and a pin projecting from the rear end of the gun, around which the ring 110 is then turned by the continued movement of its lever-handle, and the breech-piece thereby carried to one side and out of line with the bore of the gun.

2. The combination of a gun having divided 115 segments of screw-threads within its breech end, a breech-piece having corresponding segments to lock into them, and also having an inclined groove passing partly around it, a carrier-ring into which the rear end of the 120 breech-piece extends, a short arm extending from the ring and capable of being turned around a pin projecting rearward from the breech end of the gun, a ring with lever-handle extending from it capable of being turned 125 around the carrier-ring, and a pin projecting inward from the ring and entering the inclined groove in the breech-piece, the whole so disposed that on the ring being turned in one direction the breech-piece has first a partial turn 130 given to it, is then drawn back, and then by the continued movement of its lever-handle carried to one side of the gun.

3. The combination of a gun having divided

screw-segments within its breech, a breech-piece with corresponding screw-segments, a carrier-ring into which the rear end of the breech-piece extends, a short arm extending from the ring, a pin projecting rearward from the breech end of the gun, around which the arm can be turned, an extractor sliding in a longitudinal groove in the gun and having teeth upon it to engage with the screw-threads on the breech-piece, and a longitudinal groove in the carrier-ring, into which the extractor is drawn when the breech-piece is drawn back from the gun.

THORSTEN NORDENFELT.

Witnesses:

W. DUTNELL,
F. A. NOEL.