



(12) **EUROPEAN PATENT APPLICATION**

(43) Date of publication: **15.06.2005 Bulletin 2005/24** (51) Int Cl.7: **B65D 75/42, B65D 33/00**

(21) Application number: **04029330.0**

(22) Date of filing: **10.12.2004**

(84) Designated Contracting States:
**AT BE BG CH CY CZ DE DK EE ES FI FR GB GR
HU IE IS IT LI LT LU MC NL PL PT RO SE SI SK TR**
Designated Extension States:
AL BA HR LV MK YU

(72) Inventor: **Mize, James
Simpsonville South Carolina 29681 (US)**

(74) Representative: **De Carli, Eida
Sealed Air S.r.l.,
Via Trento 7
20017 Passirana di Rho (MI) (IT)**

(30) Priority: **12.12.2003 US 735092**

(71) Applicant: **Cryovac, Inc.
Duncan, S.C. 29334 (US)**

(54) **Paired bags and method of making same**

(57) A set of bags comprises a first lay-flat bag and a second lay-flat bag joined along their respective lengths. An end seal extending across both the first bag and the second bag. The first bag has a first side seal extending the length of the first bag, and the second bag has a second side-seal extending the length of the sec-

ond bag. The first bag is connected with the second bag in an area between the first side-seal and the second side-seal. Both the first bag and the second bag having a total free shrink at 185°F of at least 10 percent and a transverse free shrink at 185°F which is greater than a longitudinal free shrink at 185°F.

FIG. 1

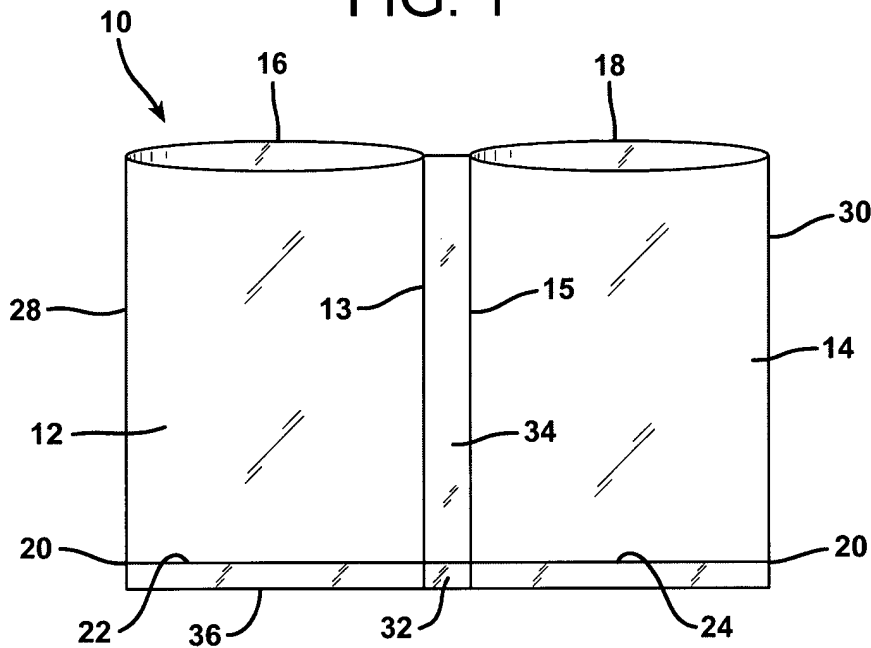

Description

Field of the Invention

5 **[0001]** The present invention relates to sets of bags made from a heat-shrinkable flexible packaging film.

Background of the Invention

10 **[0002]** Heat-shrinkable bags made from flexible thermoplastic film have for some time been used for the packaging of various products, such as food products, especially meat. An "end-seal" bag is one such bag. In the making of heat-shrinkable end-seal bags, thermoplastic material is extruded from an annular die, in the form of a seamless tubing, with the extrudate (known as a "tape") being relatively thick and relatively narrow. The annular extrudate is then quenched. Optionally, the tape can then be irradiated and/or coated with one or more additional layers containing thermoplastic polymer. The tape is then reheated to its softening point by exposure to hot water or steam (or other heating means) and is stretched in its longitudinal and transverse directions while the polymer remains in the solid state, resulting in heat-shrinkable film in the form of a seamless tubing. The heat-shrinkable film tubing is then converted into end-seal bags by placing the tubing into a lay-flat configuration and heat-sealing across the tubing to heat-seal the inside surface of the tubing to itself. The seals across the tubing are made at intervals along the length of the tubing, these intervals corresponding with the desired bag length(s). The resulting sealed tubing is then converted into a plurality of heat-shrinkable bags by cutting across the tubing a short distance downstream of each of the transverse heat-seals, resulting in a plurality of lay-flat bags having an open top, two seamless side edges, a heat seal across the bag near the bottom edge of the bag, and a short section of tubing (commonly referred to as a "skirt") below the transverse heat seal.

25 **[0003]** Because end-seal bags extend across the entire width of the lay-flat tubing, end-seal bags come off of the production line one at a time, with each bag requiring a separate sealing cycle, a separate printing cycle, and with each bag coming off the line as a single bag. It would be desirable to reduce the number of sealing cycles, printing cycles, and cutting cycles, to increase throughput of the process, and in some cases to provide bags of reduced width.

30 **[0004]** In addition, most meat processing plants have packaging equipment with large vacuum chambers for the evacuation of atmosphere and sealing of a bag containing a meat product. If two small bags are loaded into the same vacuum chamber at the same time, they may overlap and have weak seals. However, if a single small bag is loaded into the large chamber, capacity is under-utilized and additional labor is required. It would be desirable to be able to place more than one small bag into the chamber without having weak seals from bag overlap.

35 **[0005]** Side seal bags are also made by sealing across a seamless tubing. Whereas end-seal bags have a width corresponding with the lay-flat width of the seamless tubing, side-seal bags have a length corresponding to the width of the seamless tubing, and have a width corresponding to the selected distance between transverse seals which run along the side edges of side-seal bags. In the production of side-seal bags, two or more side-seal bags have been kept together and cut free of the remainder of the tubing, and used as a bag pair. However, side-seal bags have a disadvantage of having a free shrink along the length of the side-seal bag (i.e., in the transverse direction of the length of the seamless tubing) which is higher than the free shrink across the width of the side-seal bag (i.e., corresponding with the length of the tubing). Having a higher shrink across the tubing is detrimental to the packaging of relatively long, flat, flexible products in side-seal bags, as during subsequent bag-length shrinkage of a side-seal bag, the product can become distorted, i.e., "curved", which lowers the appearance of the package to a consumer, and which is more difficult to box because of the curve in the package. Moreover, paired side-seal bags cannot be provided as a continuous string of connected pairs, as to make the "pair" requires that the pair be separated from the remainder of side-seal bags formed from the tubing.

Summary Of The Invention

50 **[0006]** The present invention provides a set of heat-shrinkable bags and a process for making sets of such bags. In the process, the number of printing cycles, as well as the number of cycles used to make the transverse seals, can be cut in half, thirds, etc., while making the same total number of bags, thereby enabling a doubling, tripling, etc., of the number of bags per extrusion die, as well as per print cycle and per transverse seal cycle. In addition, the sets of heat-shrinkable bags have a lengthwise free shrink (i.e., shrink in the machine direction) which is less than the transverse free shrink (i.e., shrink across the width of the bags), so that during shrinking the heat-shrinkable bags have less tendency to distort flat, flexible, elongate products packaged in the bag.

55 **[0007]** The process can be used to produce sets of bags in which the bags of each set are connected with one another across the machine direction of the film being used to make the bags. Optionally, each set of bags can be provided with an appropriate number of longitudinal tear lines (i.e., tear lines running the length of the bags, i.e., in the

machine direction) for ease in separating the bags from one another. In addition, because the bags are connected to one another, like a single bag the connected series of bags can be stretched out across the opening of a vacuum chamber without risk of overlap during sealing.

5 [0008] Moreover, the invention can be carried out so that each set of bags is connected to at least one other set of bags in a line of succession, e.g., resulting in a strand of paired bags, which can be of indeterminate length as it comes off of a production line. Optionally, this strand of sets of bags can be provided with transverse tear lines (i.e., a weakened region between the sets of bags, such as a line of perforations, etc.) so that each set of bags can be easily torn free of the strand of bags, as well as lengthwise (i.e., machine direction) tear lines between the bags of each set, so that the packaged product can be offered as singlets or any subset of the original set of bags.

10 [0009] In the sets of bags of the invention, the bag length of each of the bags in the set runs in the machine direction of the tubing. Likewise, the bag width of each of the bags in the set runs in the transverse direction, i.e., across the tubing. A greater free shrink in the transverse direction is desirable for the packaging of a wide variety of products, particularly food products which tend to distort by bending along the length of the bag in which they are packaged. Various meat products, such as small beef and pork cuts, for example, beef and pork tenderloin, eye of round, single ribs, beef spare ribs, split beef back ribs, and various lamb cuts, tend to distort (i.e., bend) if packaged in a shrink bag having a higher shrink along the length of the bag than across the width of the bag. Such package distortion is reduced or eliminated in the sets of bags of the invention, which have have greater free shrink across the bag than along the length of the bag.

20 [0010] As a first aspect, the present invention is directed to a set of bags made from a film. The set of bags comprises a first lay-flat bag and a second lay-flat bag joined along their respective lengths, with an end seal extending across both the first bag and the second bag. The first bag has a first side seal extending the length of the first bag, and the second bag has a second side-seal extending the length of the second bag. The first bag is connected with the second bag in an area between the first side-seal and the second side-seal. Both the first bag and the second bag having a total free shrink at 185°F of at least 10 percent, and both the first bag and the second bag have a transverse free shrink at 185°F which is greater than a longitudinal free shrink at 185°F.

25 [0011] In one preferred embodiment, the set of bags has a first outer side edge and a second outer side edge, and at least one of the first outer side edge and the second outer side edge is a folded edge.

30 [0012] Preferably, the film has a total free shrink, at 185°F, of at least 15 percent; more preferably, at least 20 percent, more preferably, at least 25 percent; more preferably, at least 30 percent; more preferably, at least 35 percent; more preferably, at least 40 percent; more preferably, at least 45 percent. Preferably, the film has a total free shrink at 185°F of from 15 to 150 percent; more preferably, from 20 to 140 percent; more preferably, from 25 to 130 percent; more preferably, from 30 to 120 percent; more preferably, from 35 to 110 percent; more preferably, from 40 to 100 percent; and, more preferably, from 45 to 90 percent.

35 [0013] Preferably, the end-seal, the first side-seal, and the second side-seal are heat seals. Preferably, the end seal, the first side-seal, and the second side-seal are each a seal of an inside surface of a seamless tubing to itself. The end-seal can be a straight seal or can be curved or have at least one curved region. If curved, preferably the end-seal is curved so that the bottom of the lay-flat set of bags is convex.

40 [0014] Preferably, the set of bags further comprises a line of weakness between the first bag and the second bag, the line of weakness being between the first side seal and the second side seal. Preferably, the line of weakness between the first bag and the second bag comprises perforations.

[0015] Optionally, a patch is adhered to the first bag and/or the second bag. Preferably, the first bag has a first patch adhered thereto, and the second bag has a second patch adhered thereto. Preferably, the first bag and the second bag are both made from a film having a total free shrink at 185°F of at least 15 percent, and the first patch and the second patch are made from a film having a total free shrink at 185°F of at least 15 percent.

45 [0016] Although the set of bags can be just a pair of bags, the set of bags can further comprise a third bag between the first bag and the second bag, the third bag having two side seals and an end seal. If the set of bags is a pair of bags, the first bag is preferably a mirror image of the second bag. Preferably, the first bag has a length equal to the length of the second bag. Preferably, first side-seal is parallel to the second side-seal.

50 [0017] Preferably, the film from which the set of bags is made is a multilayer film comprising a first outer film layer, a second outer film layer, and an inner O₂-barrier layer comprising at least one polymer selected from the group consisting of vinylidene chloride/methyl acrylate copolymer, vinylidene chloride/vinyl chloride copolymer, ethylene/vinyl alcohol copolymer, polyamide, and polyethylene carbonate. Preferably, the multilayer film further comprises a fourth layer which serves as a tie layer between the barrier layer and the first outer film layer, and a fifth layer which serves as a tie layer between the barrier layer and the second outer layer.

55 [0018] Optionally, the first bag and the second bag have printing thereon.

[0019] As a second aspect, the present invention pertains to a plurality of sets of bags, with each set being in accordance with the first aspect of the invention (described above). The first set of bags comprises a first bag and a second bag joined along their respective lengths, the first pair of bags having a first end-seal extending across both

the first bag and the second bag, the first bag having a first side-seal extending the length of the first bag, and the second bag having a second side-seal extending the length of the second bag, the first bag being connected with the second bag in an area between the first side-seal and the second side seal. The second set of bags comprises a third bag and a fourth bag, the second set of bags having a second end-seal extending across both the third bag and the fourth bag, the third bag having a third side-seal extending the length of the third bag and the fourth bag having a fourth side seal extending the length of the fourth bag. The third bag is connected with the fourth bag in an area between the third side-seal and the fourth side seal. The second set of bags is joined to the first set of bags in an area below the first end seal. Preferably, the third side seal is a continuation of the first side seal, and the fourth side seal is a continuation of the second side seal. Preferably, the second set of bags is joined to the first set of bags along a transverse line of weakness. Preferably, the line of weakness between the first set of bags and the second set of bags comprises perforations. Optionally, the set of bags further comprises a third set of bags which is joined to the second set of bags below the second end seal, and a fourth set of bags joined to the third set of bags below a third end seal, with the plurality of sets of bags being a portion of a strand of sets of bags, the strand being of indeterminate length. Unless inconsistent therewith, preferred embodiments of the second aspect of the invention correspond with preferred features of the first aspect of the present invention.

[0020] As a third aspect, the present invention pertains to a set of bags made from a film. The set of bags comprises a first lay-flat bag and a second lay-flat bag joined along their respective lengths, and an end seal extending across both the first bag and the second bag, with the first bag connecting with the second bag at a heat seal between the first bag and the second bag, the heat seal extending the length of the first bag and the second bag, with both the first bag and the second bag having a total free shrink at 185°F of at least 10 percent and a transverse free shrink at 185°F which is greater than a longitudinal free shrink at 185°F. Unless inconsistent therewith, preferred embodiments of the third aspect of the invention correspond with preferred features of the first aspect of the present invention.

[0021] As a fourth aspect, the present invention pertains to a process for converting a lay-flat film tubing to a plurality of sets of bags. The process comprises making a plurality of transverse seals across the lay-flat film tubing, with the transverse seals being spaced apart from one another by a distance corresponding with the length of each of the sets of bags. Each of the transverse seals providing an end-seal across a bottom of each bag of each of the sets of bags. Then first and second longitudinal seals are made along the length of the lay-flat film tubing, the longitudinal seals providing a seal along an interior side edge of each of the sets of bags. The bags of each set of bags have a total free shrink at 185°F of at least 10 percent and a transverse free shrink at 185°F which is greater than a longitudinal free shrink at 185°F. Preferably, the lay-flat film tubing is a seamless tubing which is converted to the sets of bags by making transverse and longitudinal seals through the tubing, with each set of bags being separated from a remainder of the lay-flat tubing. Preferably, a the process further comprises making a line of weakness below each of the transverse seals. Preferably, the line of weakness is between the first and second longitudinal seals. Preferably, the line of weakness is below each of the transverse seals. Optionally, the process can be carried out by making one longitudinal seal down the length of the tubing, to produce a set of bags in accordance with the third aspect of the invention.

[0022] As a fifth aspect, the present invention pertains to a process for converting a flat film tubing to a plurality of sets of bags. The process is carried out by (A) center-folding the flat film along its length, to form a centerfolded film; (B) making a plurality of transverse seals across the centerfolded film, the seals being spaced apart from one another by a distance corresponding with the length of the sets of bags, each of the transverse seals serving as end-seals across the bottom of each of the sets of bags; (C) making first, second, and third longitudinal seals along the length of the centerfolded film, the first longitudinal seal providing a seal along and second longitudinal seals providing a seal along an interior side edge of each of the bags sets of bags. Unless inconsistent therewith, preferred embodiments of this fifth aspect of the invention correspond with preferred features of the fourth aspect of the present invention.

Brief Description of the Drawings

[0023]

FIG. 1 illustrates a lay-flat view of a set (in this illustration, a pair) of L-seal bags made from a seamless tubing.

FIG. 2 illustrates a lay-flat view of a pair of L-seal bags made from a seamless tubing, with the pair of bags being connected to one another along a longitudinal line of weakness (e.g., perforations).

FIG. 3 illustrates a portion of a continuous string of L-seal bag pairs made from a seamless tubing with a longitudinal line of weakness between the bags of each pair, with each pair of bags being connected to the next successive pair of bags with a transverse line of weakness which is a short distance downstream of the transverse seal across the bags.

FIG. 4 illustrates a lay-flat view of a set (e.g., pair) of alternative L-seal bags made from a seamless tubing, each of the bags of each set having a curved end seal.

FIG 5 illustrates a lay-flat view of an alternative pair of bags made by folding a flat film over on itself and sealing

it to form a pair of bags.

FIG. 6 illustrates a lay-flat view of an alternative set of lay-flat bags which is made up of three bags across a seamless lay-flat tubing.

FIG. 7 illustrates a lay-flat view of a set of L-seal patch bags made from a seamless tubing to which a pair of patches are adhered.

FIG. 8 illustrates a schematic of a preferred process for producing the multilayer films for use in the sets of bags of the present invention.

FIG. 9 illustrates a lay-flat view of an alternative pair of L-seal bags in accordance with the present invention.

Detailed Description of the Invention

[0024] As used herein, the term "bag" is inclusive of L-seal bags, side-seal bags, backseamed bags, and pouches (i.e., "U-sealed" bags). An L-seal bag has an open top, a bottom seal, one side-seal along a first side edge, and a seamless (i.e., folded, unsealed) second side edge. A side-seal bag has an open top, a seamless bottom edge, with each of its two side edges having a seal therealong. Although seals along the side and/or bottom edges can be at the very edge itself, (i.e., seals of a type commonly referred to as "trim seals"), preferably the seals are spaced inward (preferably 1/4 to 1/2 inch, more or less) from the bag side edges, and preferably are made using a impulse-type heat sealing apparatus, which utilizes a bar which is quickly heated and then quickly cooled. A backseamed bag is a bag having an open top, a seal running the length of the bag in which the bag film is either fin-sealed or lap-sealed, two seamless side edges, and a bottom seal along a bottom edge of the bag.

[0025] As used herein, the phrase "set of bags" refers to two or more bags which are connected with one another in a side-by-side relationship, with the bags extending across a tubing (seamed or seamless). The set of bags preferably comprises from 2 to 20 bags across the tubing, more preferably from 2 to 5 bags, more preferably 2 to 3 bags. Each bag preferably has a length of at least twice its width, more preferably three to ten times its width, with bag length and bag width being measured based on inside the bag dimensions while the bag is in a lay-flat position. The phrase "connected with", as applied to the bags of a single set of bags, refers to the side-by-side relationship of the bags to one another, and does not require that the bags be directly adhered to one another. That is, two bags are connected with one another even if a third bag is between them or even if a section of waste film is between them. Likewise, two bags are connected with one another if they share as common side seal, as illustrated in FIG. 9, described below.

[0026] The phrases "lay-flat film tubing", "lay-flat bag", and "lay-flat width" are known to those of skill in the flexible film art. A lay-flat film tubing is extruded through an annular die, with the extrudate being cooled and gathered by converging sets of rollers and wound up in flattened form. A lay-flat bag includes end-seal, side-seal, L-seal, etc. bags which can be made by sealing the inside of a lay-flat film tubing to itself, following by cutting across the tubing to convert the tubing into, for example, an end-seal bag. A side seal bag requires slitting one side edge of the tubing in addition to cutting across the tubing. Side-seal and L-seal lay-flat bags can also be made by folding a flat film and sealing the inside surface of the folded film to itself. A pouch is often made by sealing two separate pieces of flat film to one another, with the seals extending up the sides of the pouch and across the bottom of the pouch, leaving the top of the bag open for the insertion of the product to be packaged.

[0027] As used herein, the phrase "line of weakness" refers to any line, whether straight or curved, whether wide or narrow, in which the film has been weakened by any means so that the film can readily be torn apart along the line. Preferably the line of weakness is formed by perforating the film.

[0028] As used herein, the phrases "heat-shrinkable film," "heat-shrink film" and the like refers to a film which has been oriented while in the solid state (as opposed to a blown film, which is oriented at, above, or near the melting point of the polymer). The tension on a heat-shrinkable film increases upon the application of heat if the film is restrained from shrinking. As a corollary, the phrase "heat-contracted" refers to a heat-shrinkable film, or a portion thereof, which has been exposed to heat such that the film or portion thereof is in a heat-shrunken state, i.e., reduced in size (unrestrained) or under increased tension (restrained). Preferably, the heat shrinkable film has a total free shrink (i.e., machine direction plus transverse direction), with the free shrink in each direction (measured in accordance with ASTM D 2732) of at least as 5 percent at 185°C, more preferably at least 7 percent, still more preferably, at least 10 percent, still more preferably, at least 15 percent, and, yet still more preferably, at least 20 percent. The total free shrink at 185°F can be from 10 to 150 percent, more preferably from 20 to 120 percent, more preferably from 40 to 100 percent.

[0029] As used herein, the phrases "inner layer" and "internal layer" refer to any layer, of a multilayer film, having both of its principal surfaces directly adhered to another layer of the film.

[0030] As used herein, the phrase "outer layer" refers to any film layer of film having less than two of its principal surfaces directly adhered to another layer of the film. The phrase is inclusive of monolayer and multilayer films. In multilayer films, there are two outer layers, each of which has a principal surface adhered to only one other layer of the multilayer film. In monolayer films, there is only one layer, which, of course, is an outer layer in that neither of its two principal surfaces are adhered to another layer of the film.

[0031] As used herein, the phrase "inside layer" refers to the outer layer of a multilayer film packaging a product, which is closest to the product, relative to the other layers of the multilayer film.

[0032] As used herein, the phrase "outside layer" refers to the outer layer, of a multilayer film packaging a product, which is furthest from the product relative to the other layers of the multilayer film. Likewise, the "outside surface" of a bag is the surface away from the product being packaged within the bag.

[0033] As used herein, the term "adhered" is inclusive of films which are directly adhered to one another using a heat seal or other means, as well as films which are adhered to one another using an adhesive which is between the two films.

[0034] Although the films used in the patch bag according to the present invention can be monolayer films or multilayer films, the patch bag comprises at least two films laminated together. Preferably, the patch bag is comprised of films which together comprise a total of from 2 to 20 layers; more preferably, from 2 to 12 layers; and still more preferably, from 4 to 12 layers. In general, the multilayer film(s) used in the present invention can have any total thickness desired, so long as the film provides the desired properties for the particular packaging operation in which the film is used, e. g. abuse-resistance (especially puncture-resistance), modulus, seal strength, optics, etc.

[0035] FIG. 1 is a lay-flat view of a pair of L-seal bags 10 which have been made by sealing the inside layer of a flexible, thermoplastic seamless tubing to itself. Pair of bags 10 comprises first bag 12 and second bag 14, which in turn have open tops 16 and 18, respectively, and transverse seal 20, with end seal portion 22 serving as the end seal for first bag 12 and end seal portion 24 serving as the end seal for second bag 14. First bag 12 has inner longitudinal seal 13 and second bag 14 has inner longitudinal seal 15. Together end seal portion 22 and inner longitudinal seal 13 make up a so-called "L-seal" of first bag 12, with the same being present for the combination of end seal portion 24 and inner longitudinal seal 15 for second bag 14. First bag 12 and second bag 14 share central region 34, which as illustrated has no weakened line, so that products packaged in first bag 12 and second bag 14 are paired with one another unless cut apart along the length of central region 34. Side edge 28 of first bag 12 is a folded edge (which usually is creased during processing of the seamless tubing from which the bags are formed), as is side edge 30 of second bag 14. Skirt region 32 is below transverse seal 20, with skirt region 32 extending all the way across both first bag 12 and second bag 14, i.e., from side edge 28 to side edge 30, with skirt region 32 extending from immediately below transverse seal 20 to bottom edge 36.

[0036] FIG. 2 is a lay-flat view of a L-seal bag pair 40 having features which correspond with the features of the pair of bags illustrated in FIG. 1, except that L-seal bag pair 40 additionally has a longitudinal line of weakness 42 running the length of central region 34. Line of weakness 42 is preferably a set of perforations aligned along a straight line which is located in the middle of central region 34, and which runs the entire length of central region 34.

[0037] FIG. 3 illustrates continuous string 50 of L-seal bag pairs 40 having all of the feature as illustrated in FIG. 2. However, in continuous string 50, immediately beneath skirt 32 of each bag pair 40, is transverse line of weakness 52. Line of weakness 52 is preferably a set of perforations aligned along a straight line located far enough below transverse seal 32 to provide skirt 32 with adequate width.

[0038] FIG. 4 is a lay-flat view of alternative L-seal bag pair 80 having features which largely correspond with the features of the pair of bags illustrated in FIG. 2, except that transverse seal 82 has curved sections 84 and 86, which provide end-seals across the bottom of first bag 88 and second bag 90, respectively. Likewise, matching curved sections are present at open top 92 and 94 of first bag 88 and second bag 90, respectively.

[0039] FIG. 5 is an illustration of an alternative pair of bags 60 comprising first bag 62 and second bag 64 which can be made by centerfolding a flat film (or slitting a seamless tubing). First bag 62 and second bag 64 have open tops 16 and 18, respectively. Pair of bags 60 has transverse seal 20, with seal sections 22 and 24 serving as the end seal for first bag 62 and second bag 64, respectively. In addition, first bag 62 has outer folded edge 28 and inner longitudinal seal 13 (i.e., first bag 62 being an L-seal bag). In addition to end seal section 24, second bag 64 has both inner longitudinal seal 15 and outer longitudinal seal 66 (i.e., second bag 64 being a U-seal bag). Second bag 64 also has skirt 68 running the length of the bag, between outer longitudinal seal 66 and outer edge 70. As in FIG. 1, pair of bags 60 share central region 34, which as illustrated has no weakened line, so that products packaged in first bag 62 and second bag 64 are paired with one another unless cut apart along the length of central region 34.

[0040] FIG. 6 illustrates a lay-flat view of an alternative set of lay-flat bags (100) including first bag 102 along a first folded side edge of the seamless tubing, second bag 104 along a second folded side edge of the seamless tubing, and third bag 106 positioned between first bag 102 and second bag 104. Each of bags 102, 104, and 106 shares transverse end seal 108, and first bag 102 is an L-seal bag utilizing a portion of end seal 108 in combination with first side seal 110. Second bag 104 is also an L-seal bag, also utilizing a portion of end seal 108, but in combination with second side seal 112. Third bag 106 is a U-seal bag utilizing yet another portion of end seal 108, together with third side seal 114 and fourth side seal 116. While side seals 110, 112, 114, and 116 are termed side seals because they each run along a side edge of respective bags 102, 104, and 106, they each run in the machine direction. First bag 102 is joined to third bag 106 along line of weakness 118 (preferably a line of perforations), and second bag 104 is joined to third bag 106 along line of weakness 120 (preferably also a line of perforations).

EP 1 541 493 A1

[0041] FIG. 7 illustrates a lay-flat view of a pair of bags 122 which correspond with pair of bags 40 illustrated in FIG. 2, except that first bag 124 has patch 128 adhered thereto, and second bag 126 has patch 130 adhered thereto.

[0042] Preferably, the film stock film from which the bag is formed has a total thickness of from about 1.5 to 5 mils; more preferably, 1.5 to 4 mils; more preferably, 2 to 3 mils; more preferably, 2 to 2.5 mils. Preferably the stock film from which the bag is formed is a multilayer film having from 1 to 20 layers; more preferably, 3 to 10 layers; more preferably, 4 to 8 layers.

[0043] Preferably, the bag film, present in the form of a seamless tubing, backseamed tubing (lap seal, fin seal, or butt sealed backseamed tubing with butt seal tape) or as a flat film, has a total (i.e., L + T) free shrink at 185°F of from about 45 to 125 percent, with a free shrink in the longitudinal (i.e., machine) direction of from 20 to 50 percent, and a free shrink in the transverse direction of from 25 to 75 percent, with the transverse free shrink being greater than the longitudinal free shrink. More preferably, the bag film has a total free shrink at 185°F of from about 55 to 110 percent, with a free shrink in the longitudinal direction of from 25 to 45 percent, and a free shrink in the transverse direction of from 30 to 65 percent, again with the transverse free shrink being greater than the longitudinal free shrink. More preferably, the bag film has a total free shrink at 185°F of from about 65 to 95 percent, with a free shrink in the longitudinal direction of from 30 to 40 percent, and a free shrink in the transverse direction of from 35 to 55 percent, again with the transverse free shrink being greater than the longitudinal free shrink.

[0044] Preferably, the transverse free shrink at 185°F is higher than the longitudinal free shrink at 185°F by an amount of from about 5 to 30 percent, more preferably from 8 to 20 percent higher. Preferably, the transverse free shrink is from 1.1 times to 1.8 times as high as the longitudinal free shrink, more preferably from 1.2 to 1.7 times as high, more preferably from 1.25 to 1.65 times as high.

[0045] Table I, below, provides a preferred multilayer film structure for making a set of bags in accordance with the present invention, including the composition, thickness, and general function of each of the film layers. This film, extruded from an annular die and thereafter extrusion coated, was in the form of a seamless tubing and had a total thickness of approximately 2.4 mils, and exhibited a total free shrink at 185°F of 20% in the machine direction and 33% in the transverse direction.

TABLE I

Layer Function	Layer Chemical Identity	Layer Thickness (mils)
Outside and abuse layer	90% EVA #1 10% HDPE #1	0.58
O ₂ -Barrier layer	96% VDC/MA #1; 2% epoxidized soybean oil; and 2% bu-A/MA/bu-MA terpolymer	0.19
Puncture-resistant	85% LLDPE #1 & 15% EBA #1	1.15
Sealant and inside layer	80% SSPE#1 20% LLDPE #2	0.48

[0046] In Table I, LLDPE #1 was DOWLEX® 2045 linear low density polyethylene, obtained from the Dow Chemical Company of Midland, Michigan. LLDPE #2 was ESCORENE® LL3003.32 linear low density polyethylene, obtained from Exxon Chemical Company of Baytown, Texas. SSPE#1 was AFFINITY® P11280 metallocene-catalyzed ethylene/octene copolymer, having a density of 0.900 g/cc and a melt index of 6 g/10 min, obtained from The Dow Chemical Company, of Midland, Michigan. HDPE #1 was Fortiflex® T60-500-119 high density polyethylene, obtained from Solvay Polymers, of Deer Park, Texas. EVA No. 1 was ESCORENE® LD318.92 ethylene/vinyl acetate copolymer having a melt index of 2.0, a density of 0.930 g/cc, and a vinyl acetate mer content of 9 percent, this resin being obtained from the Exxon Chemical Company. EBA No. 1 was SP1802 ethylene/butyl acrylate copolymer containing 18% butyl acrylate, obtained from Chevron Chemical Company, of Houston, Texas. Table II, below, provides another preferred multilayer film structure for making the sets of bags in accordance with the present invention, the film having a total thickness of 3 mils and a free shrink at 185°F of 28 percent in the machine direction and 36 percent in the transverse direction.

TABLE II

Layer Function	Layer Chemical Identity	Layer Thickness (mils)
Outside and abuse layer	80% SSPE2 20% LLDPE3	0.21
Core Layer	100% LLDPE2	0.32

EP 1 541 493 A1

TABLE II (continued)

Layer Function	Layer Chemical Identity	Layer Thickness (mils)
Tie Layer	100% EMA	0.11
O ₂ -Barrier layer	96% VDC/MA #1; 2% epoxidized soybean oil; and 2% bu-A/MA/bu-MA terpolymer	0.21
Tie Layer	100% EVA 1	0.11
Substrate Core Layer	60%LLDPE2 40% LLDPE3	1.5
Seal Layer	60% SSPE1 40% LLDPE 1	0.56

[0047] Table III, below, provides another preferred multilayer film structure for making the sets of bags in accordance with the present invention, the film having a total thickness of about 2.2 mils and a free shrink at 185°F of about 31% in the machine direction and about 44% in the transverse direction.

TABLE III

Layer Function	Layer Chemical Identity	Layer Thickness (mils)
Outside and abuse layer	85% SSPE2 15% LLDPE3	0.19
Core Layer	100% LLDPE2	0.29
Tie Layer	100% EMA	0.1
O ₂ -Barrier layer	96% VDC/MA ; 2% epoxidized soybean oil; and 2% bu-A/MA/bu-MA terpolymer	0.19
Tie Layer	100% EVA1	0.1
Substrate Core Layer	80%LLDPE2 20% LLDPE3	0.86
Seal Layer	80% SSPE1 20% LLDPE 1	0.48

[0048] Table IV, below, provides another preferred multilayer film structure for making the sets of bags in accordance with the present invention, the film having a total thickness of 2.3 mils and a free shrink at 185°F of 25 in the machine direction and 41 in the transverse direction.

TABLE IV

Layer Function	Layer Chemical Identity	Layer Thickness (mils)
Outside and abuse layer	100% EVA4	0.6
O ₂ -Barrier layer	96% VDC/MA # 1; 2% epoxidized soybean oil; and 2% bu-A/MA/bu-MA terpolymer	0.17
Substrate Core Layer	100% EVA4	1.28
Seal Layer	100% LDPE	0.26

[0049] Table V, below, provides another preferred multilayer film structure for making the sets of bags in accordance with the present invention, the film having a total thickness of 2 mils and a free shrink at 185°F of 31 in the machine direction and 46 in the transverse direction.

EP 1 541 493 A1

TABLE V

Layer Function	Layer Chemical Identity	Layer Thickness (mils)
Outside and abuse layer	85% SSPE2 15% LLDPE3	0.18
Core Layer	100% LLDPE2	0.27
Tie Layer	100% EMA	0.09
02-Barrier layer	96% VDC/MA # 1; 2% epoxidized soybean oil; and 2% bu-A/MA/bu-MA terpolymer	0.18
Tie Layer	100% EVA 1	0.09
Substrate Core Layer	80% LLDPE2 20% LLDPE3	0.73
Seal Layer	90% SSPE1 10% MB1	0.45

[0050] Table VI, below, provides another preferred multilayer film structure for making the sets of bags in accordance with the present invention, the film having a total thickness of 2 mils and a free shrink at 185°F of 26 in the machine direction and 42 in the transverse direction.

TABLE VI

Layer Function	Layer Chemical Identity	Layer Thickness (mils)
Outside and abuse layer	85% EVA3 15% LLDPE3	0.27
Core Layer	100% LLDPE2	0.4
Core Layer	100% EVA3	.13
Core Layer	100% EVA3	0.09
Substrate Core Layer	76% LLDPE2 24% MB2	0.8
Seal Layer	100% LLDPE4	0.31

[0051] Table VII, below, provides another preferred multilayer film structure for making the sets of bags in accordance with the present invention, the film having a total thickness of 2.2 mils and a free shrink at 185°F of 36 in the machine direction and 51 in the transverse direction.

TABLE VII

Layer Function	Layer Chemical Identity	Layer Thickness (mils)
Outside and abuse layer	100% SSPE2	0.19
Core Layer	100% SSCPE3	0.29
Tie Layer	100% EVA2	0.10
02-Barrier layer	96% VDC/MA # 1; 2% epoxidized soybean oil; and 2% bu-A/MA/bu-MA terpolymer	0.19
Tie Layer	100% EVA 1	0.10
Substrate Core Layer	90% SSCPE3 10% EPD	0.86
Seal Layer	100% SSPE1	0.48

[0052] In Tables II through VII, SSPE1 was Dow Affinity® PL 1280 ethylene/octene copolymer, having a density of 0.900 g/cc and a melt index of 6 g/10min. SSPE2 was Dow Affinity® PL 1850, having a density of 0.902 g/cc and a melt index of 3 g/10 min. SSCPE3 was DPF 1150.01 single site catalyzed ethylene/octene copolymer having a density of 0.901 g/cc and a melt index of 0.9 g/10 min, obtained from Dow. LLDPE1 was Exxon Escorene® LL3003.32 linear low density polyethylene having a density of 0.9175 g/cc and a melt index of 3.2 g/10 min. LLDPE2 was Dow Attane® 4203, having a density of 0.905 g/cc and a melt index of 0.8 g/10 min. LLDPE3 is Dow Dowlex® 2045.03 linear low density polyethylene, having a density of 0.92 g/cc and a melt index of 1.1 g/10 min. LLDPE4 was Exceed® 4518PA ethylene/hexene copolymer having a density of 0.918 and a melt index of 4.5 g/10min. LDPE was Ruxell® V3401 ethylene/octene copolymer having a density of 0.911 g/cc and a melt index of 5.7 to 7.5 g/10 min, obtained from Huntsman. EVA1 was LD-713.93 ethylene/vinyl acetate copolymer, having a vinyl acetate content of 15 percent, a density of 0.933 g/cc and a melt index of 3.5 g/10 min, and was obtained from Exxon. EVA2 was Escorene® LD 761.36 ethylene/vinyl acetate copolymer having a density of 0.95 g/cc, a melt index of 5.7 g/10 min, and a vinyl acetate content of 28 percent, obtained from ExxonMobil. EVA3 was Escorene® LD 318.92 ethylene/vinyl acetate copolymer having a density of 0.93 g/cc, a melt index of 2 g/10 min, and a vinyl acetate content of 9 percent, obtained from ExxonMobil. EVA4 was Elvax® 3128 ethylene/vinyl acetate copolymer having a density of 0.928 g/cc, a melt index of 2 g/10 min, and a vinyl acetate content of 8.9%, obtained from DuPont. EMA was EMAC SP 1305 ethylene/methyl acrylate copolymer, having a methyl acrylate content of 20 percent, a density of 0.944 g/cc and a melt index of 2 g/10 min, also obtained from Exxon. EPD was Vistalon® 7800 ethylene/propylene/diene terpolymer, having a density of 0.87 g/cc and a melt index of 1.5 g/10 min, obtained from Exxon. VDC/MA was SARAN® MA-134 vinylidene chloride/methyl acrylate copolymer, obtained from the Dow Chemical Company. The epoxidized soybean oil was PLAS-CHEK® 775 epoxidized soybean oil, obtained from the Bedford Chemical Division of Ferro Corporation, of Walton Hills, Ohio. Bu-A/MA/bu-MA terpolymer was METABLEN® L-1000 butyl acrylate/methyl methacrylate/butyl methacrylate terpolymer, obtained from Elf Atochem North America, Inc., of 2000 Market Street, Philadelphia, Pennsylvania 19103. MB1 was FSU 93E polyethylene masterbatch with slip and antiblock, having a density of 0.975 g/cc and a melt index of 7.5 g/10 min, obtained from A. Schulman. MB2 was 180637 light cream masterbatch having a density of 1.25 g/cc, obtained from Ampacet.

[0053] Figure 8 illustrates a schematic of a preferred process for producing the multilayer films described in Tables I, II, and III, above. In the process illustrated in Figure 8, solid polymer beads (not illustrated) are fed to a plurality of extruders 140 (for simplicity, only one extruder is illustrated). Inside extruders 140, the polymer beads are forwarded, melted, and degassed, following which the resulting bubble-free melt is forwarded into die head 142, and extruded through an annular die, resulting in tubing 144 which is 10 to 30 mils thick, more preferably 15 to 25 mils thick.

[0054] After cooling or quenching by water spray from cooling ring 146, tubing 144 is collapsed by pinch rolls 148, and is thereafter fed through irradiation vault 150 surrounded by shielding 152, where tubing 144 is irradiated with high energy electrons (i.e., ionizing radiation) from iron core transformer accelerator 154. Tubing 144 is guided through irradiation vault 150 on rolls 156. Preferably, tubing 144 is irradiated to a level of about 4.5 MR.

[0055] After irradiation, irradiated tubing 158 is directed through nip rolls 160, following which tubing 158 is slightly inflated, resulting in trapped bubble 162. However, at trapped bubble 162, the tubing is not significantly drawn longitudinally, as the surface speed of nip rolls 164 are about the same speed as nip rolls 160. Furthermore, irradiated tubing 158 is inflated only enough to provide a substantially circular tubing without significant transverse orientation, i.e., without stretching.

[0056] Slightly inflated, irradiated tubing 158 is passed through vacuum chamber 166, and thereafter forwarded through coating die 168. Second tubular film 170 is melt extruded from coating die 168 and coated onto slightly inflated, irradiated tube 158, to form two-ply tubular film 172. Second tubular film 170 preferably comprises an O₂-barrier layer, which does not pass through the ionizing radiation. Further details of the above-described coating step are generally as set forth in U.S. Patent No. 4,278,738, to BRAX et. al., which is hereby incorporated by reference thereto, in its entirety.

[0057] After irradiation and coating, two-ply tubing film 172 is wound up onto windup roll 174. Thereafter, windup roll 174 is removed and installed as unwind roll 176, on a second stage in the process of making the tubing film as ultimately desired. Two-ply tubular film 172, from unwind roll 176, is unwound and passed over guide roll 178, after which two-ply tubular film 172 passes into hot water bath tank 180 containing hot water 182. The now collapsed, irradiated, coated tubular film 172 is submersed in hot water 182 (having a temperature of about 210°F) for a retention time of at least about 5 seconds, i.e., for a time period in order to bring the film up to the desired temperature for biaxial orientation. Thereafter, irradiated tubular film 172 is directed through nip rolls 184, and bubble 186 is blown, thereby transversely stretching tubular film 172. Furthermore, while being blown, i.e., transversely stretched, nip rolls 188 draw tubular film 172 in the longitudinal direction, as nip rolls 188 have a surface speed higher than the surface speed of nip rolls 184. As a result of the transverse stretching and longitudinal drawing, irradiated, coated biaxially-oriented blown tubing film 190 is produced, this blown tubing preferably having been both stretched in a ratio of from about 1:1.5 - 1:6, and drawn in a ratio of from about 1:1.5-1:6. More preferably, the stretching and drawing are each performed a ratio of from about

1:2 - 1:4. The result is a biaxial orientation of from about 1:2.25 - 1:36, more preferably, 1:4 - 1:16. While bubble 186 is maintained between pinch rolls 184 and 188, blown tubing film 190 is collapsed by rolls 192, and thereafter conveyed through nip rolls 188 and across guide roll 194, and then rolled onto wind-up roll 196. Idler roll 198 assures a good wind-up.

5 **[0058]** FIG. 9 illustrates a lay-flat view of an alternative set of lay-flat L-seal bags 200, also in accordance with the present invention. Set of bags 200 has been made by sealing the inside layer of a flexible, thermoplastic seamless tubing to itself. Pair of bags 200 comprises first bag 202 and second bag 204, which in turn have open tops 206 and 208, respectively, and transverse seal 210, with end seal portion 212 serving as the end seal for first bag 202 and end seal portion 214 serving as the end seal for second bag 204. First bag 202 is connected with second bag 204 longitudinal seal 216. First bag 202 and second bag 204 share seal 216, so that products packaged in first bag 12 and second bag 14 are paired with one another. Side edge 218 of first bag 202 is a folded edge (which usually is created during processing of the seamless tubing from which the bags are formed), as is side edge 220 of second bag 204. Skirt region 222 is below transverse seal 210, with skirt region 222 extending all the way across both first bag 202 and second bag 204, i.e., from side edge 218 to side edge 220, with skirt region 222 extending from immediately below transverse seal 210 to bottom edge 224.

15 **[0059]** The polymer components used to fabricate multilayer films for use in making the bags of the present invention may also contain appropriate amounts of other additives normally included in such compositions. These include anti-blocking agents (such as talc), slip agents (such as fatty acid amides), fillers, pigments and dyes, radiation stabilizers (including antioxidants), fluorescence additives (including a material which fluoresces under ultraviolet radiation), anti-static agents, elastomers, viscosity-modifying substances (such as fluoropolymer processing aids) and the like additives known to those of skill in the art of packaging films.

20 **[0060]** The multilayer films used to make the bags of the present invention are preferably irradiated to induce crosslinking, as well as corona treated to roughen the surface of the films which are to be adhered to one another. In the irradiation process, the film is subjected to an energetic radiation treatment, such as corona discharge, plasma, flame, ultraviolet, X-ray, gamma ray, beta ray, and high energy electron treatment, which induce cross-linking between molecules of the irradiated material. The irradiation of polymeric films is disclosed in U.S. Patent No. 4,064,296, to BORNSTEIN, et. al., which is hereby incorporated in its entirety, by reference thereto. BORNSTEIN, et. al. Discloses the use of ionizing radiation for crosslinking the polymer present in the film.

25 **[0061]** Radiation dosages are referred to herein in terms of the radiation unit "RAD", with one million RADS, also known as a megarad, being designated as "MR", or, in terms of the radiation unit kiloGray (kGy), with 10 kiloGray representing 1 MR, as is known to those of skill in the art. A suitable radiation dosage of high energy electrons is in the range of up to about 16 to 166 kGy, more preferably about 40 to 90 kGy, and still more preferably, 55 to 75 kGy. Preferably, irradiation is carried out by an electron accelerator and the dosage level is determined by standard dosimetry processes. Other accelerators such as a van der Graaf or resonating transformer may be used. The radiation is not limited to electrons from an accelerator since any ionizing radiation may be used.

30 **[0062]** As used herein, the phrases "corona treatment" and "corona discharge treatment" refer to subjecting the surfaces of thermoplastic materials, such as polyolefins, to corona discharge, i.e., the ionization of a gas such as air in close proximity to a film surface, the ionization initiated by a high voltage passed through a nearby electrode, and causing oxidation and other changes to the film surface, such as surface roughness.

35 **[0063]** Corona treatment of polymeric materials is disclosed in U.S. Patent No. 4,120,716, to BONET, issued October 17, 1978, herein incorporated in its entirety by reference thereto, discloses improved adherence characteristics of the surface of polyethylene by corona treatment, to oxidize the polyethylene surface. U.S. Patent No. 4,879,430, to HOFFMAN, also hereby incorporated in its entirety by reference thereto, discloses the use of corona discharge for the treatment of plastic webs for use in meat cook-in packaging, with the corona treatment of the inside surface of the web to increase the adhesion of the meat to the proteinaceous material. Although corona treatment is a preferred treatment of the multilayer films used to make the patch bag of the present invention, plasma treatment of the film may also be used.

40 **[0064]** A multilayer film is preferably converted to the bags of the present invention by heat sealing both across the film (i.e., a transverse heat seal) as well as heat sealing in the machine direction along the length of the film (i.e., a machine direction seal). The transverse seal is preferably made using a heat sealing method known as "impulse sealing", which is carried out by placing a seal bar across the film and thereafter momentarily passing current through a heat seal wire on the seal bar. The seal wire heats up, transferring heat through a first side of the film tubing (or folded film) to the other side, causing the film to be sealed to itself. This sealing method is well known to those of skill in the art.

45 **[0065]** The lengthwise heat sealing (i.e., machine direction heat sealing) can be carried out using a seal bar and impulse sealing, i.e., in the same manner that the transverse seals are made. However, impulse heat sealing is generally carried out by forwarding the film intermittently in a direction along the length of the film tubing or sheet. If continuous forwarding of the film is desired during lengthwise heat sealing, a continuous band sealer can be used. Such continuous band heat sealers are described in U.S. Patent No. 5,858,153, to Mack, entitled "Method for Making Tubular Contain-

ers", as well as U.S. Patent No. 6,344,258 B1, to Rasmussen, entitled "Heat-Sealing Polymer Films", and U.S. Patent No. 5,034,088, to Denker, entitled "Band Wheel and Tension Control", each of which is hereby incorporated, in its entirety, by reference thereto. Continuous band sealers are available from, for example, Lamination Plus, 1142 West Flint Meadow Drive, P.O. Box 121, Kaysville, Utah, 84037, and Pierce Packaging Equipment, Inc., 217 South Claremont Street, San Mateo, California, 94401.

[0066] Although the present invention has been described in connection with the preferred embodiments, it is to be understood that modifications and variations may be utilized without departing from the principles and scope of the invention, as those skilled in the art will readily understand. Accordingly, such modifications may be practiced within the scope of the following claims.

Claims

1. A set of bags made from a film, the set of bags comprising a first lay-flat bag and a second lay-flat bag joined along their respective lengths, an end seal extending across both the first bag and the second bag, the first bag having a first side seal extending the length of the first bag, and the second bag having a second side-seal extending the length of the second bag, with the first bag being connected with the second bag in an area between the first side-seal and the second side-seal, with both the first bag and the second bag having a total free shrink at 185°F of at least 10 percent and a transverse free shrink at 185°F which is greater than a longitudinal free shrink at 185°F.
2. The set of bags according to Claim 1, wherein the set of bags has a first outer side edge and a second outer side edge, and at least one of the first outer side edge and the second outer side edge is a folded edge.
3. The set of bags according to Claim 1, wherein the film has a total free shrink, at 185°F, of at least 15 percent.
4. The set of bags according to Claim 1, wherein the end-seal, the first side-seal, and the second side-seal are heat seals.
5. The set of bags according to Claim 1, wherein the end seal, the first side-seal, and the second side-seal are each a seal of an inside surface of a seamless tubing to itself.
6. The set of bags according to Claim 1, further comprising a line of weakness between the first bag and the second bag, the line of weakness being between the first side seal and the second side seal.
7. The set of bags according to Claim 6, wherein the line of weakness between the first bag and the second bag comprises perforations.
8. The set of bags according to Claim 1, wherein a patch is adhered to at least one member selected from the group consisting of the first bag and the second bag.
9. The set of bags according to Claim 8, wherein the first bag has a first patch adhered thereto, and the second bag has a second patch adhered thereto.
10. The set of bags according to Claim 9, wherein the first bag and the second bag are both made from a film having a total free shrink at 185°F of at least 15 percent, and the first patch and the second patch are made from a film having a total free shrink at 185°F of at least 15 percent.
11. The set of bags according to Claim 1, further comprising a third bag between the first bag and the second bag, the third bag having two side seals and an end seal.
12. The set of bags according to Claim 1, wherein the set is a pair of bags.
13. The set of bags according to Claim 1, wherein the film is a multilayer film comprising a first outer film layer, a second outer film layer, and an inner O₂-barrier layer comprising at least one polymer selected from the group consisting of vinylidene chloride/methyl acrylate copolymer, vinylidene chloride/vinyl chloride copolymer, ethylene/vinyl alcohol copolymer, polyamide, and polyethylene carbonate.
14. The set of bags according to Claim 13, wherein the multilayer film further comprises a fourth layer which serves

as a tie layer between the barrier layer and the first outer film layer, and a fifth layer which serves as a tie layer between the barrier layer and the second outer layer.

5 15. The set of bags according to Claim 1, wherein both the first bag and the second bag have printing thereon.

16. A plurality of sets of bags, comprising:

10 (A) a first set of bags comprising a first bag and a second bag joined along their respective lengths, the first pair of bags having a first end-seal extending across both the first bag and the second bag, the first bag having a first side-seal extending the length of the first bag, and the second bag having a second side-seal extending the length of the second bag, the first bag being connected with the second bag in an area between the first side-seal and the second side seal,

15 (B) a second set of bags comprising a third bag and a fourth bag, the second set of bags having a second end-seal extending across both the third bag and the fourth bag, the third bag having a third side-seal extending the length of the third bag and the fourth bag having a fourth side seal extending the length of the fourth bag, the third bag being connected with the fourth bag in an area between the third side-seal and the fourth side seal; and

20 wherein the second set of bags is joined to the first set of bags in an area below the first end seal.

17. The plurality of sets of bags according to Claim 16, wherein the second set of bags is joined to the first set of bags along a transverse line of weakness.

25 18. The plurality of sets of bags according to Claim 17, wherein the line of weakness between the first set of bags and the second set of bags comprises perforations.

30 19. The plurality of sets of bags according to Claim 16, further comprising a third set of bags which is joined to the second set of bags below the second end seal, and a fourth set of bags joined to the third set of bags below a third end seal, with the plurality of sets of bags being a portion of a strand of sets of bags, the strand being of indeterminate length.

35 20. A set of bags made from a film, the set of bags comprising a first lay-flat bag and a second lay-flat bag joined along their respective lengths, an end seal extending across both the first bag and the second bag, with the first bag connecting with the second bag at a heat seal between the first bag and the second bag, the heat seal extending the length of the first bag and the second bag, with both the first bag and the second bag having a total free shrink at 185°F of at least 10 percent and a transverse free shrink at 185°F which is greater than a longitudinal free shrink at 185°F.

40 21. A process for converting a lay-flat film tubing to a plurality of sets of bags, comprising:

A. making a plurality of transverse seals across the lay-flat film tubing, the transverse seals being spaced apart from one another by a distance corresponding with the length of each of the sets bags, each of the transverse seals providing an end-seal across a bottom of each bag of each of the sets of bags;

45 B. making first and second longitudinal seals along the length of the lay-flat film tubing, the longitudinal seals providing a seal along an interior side edge of each of the sets of bags;

wherein the bags of each set of bags have a total free shrink at 185°F of at least 10 percent and a transverse free shrink at 185°F which is greater than a longitudinal free shrink at 185°F.

50 22. The process according to Claim 21, wherein the lay-flat film tubing is a seamless tubing, and after forming a set of bags from the lay-flat tubing by making the transverse and longitudinal seals, the set of bags is separated from a remainder of the lay-flat tubing.

55 23. The process according to Claims 22, further comprising making a transverse line of weakness below each of the transverse seals.

24. The process according to Claim 23, further comprising making a longitudinal line of weakness between the first and second longitudinal seals.

EP 1 541 493 A1

25. A process for converting a flat film tubing to a plurality of sets of bags, comprising:

A. center folding the flat film along its length, to form a centerfolded film;

B. making a plurality of transverse seals across the centerfolded film, the seals being spaced apart from one another by a distance corresponding with the length of the sets of bags, each of the transverse seals serving as end-seals across the bottom of each of the sets of bags;

C. making first, second, and third longitudinal seals along the length of the centerfolded film, the first longitudinal seal providing a seal along and second longitudinal seals providing a seal along an interior side edge of each of the bags sets of bags.

5

10

15

20

25

30

35

40

45

50

55

FIG. 1

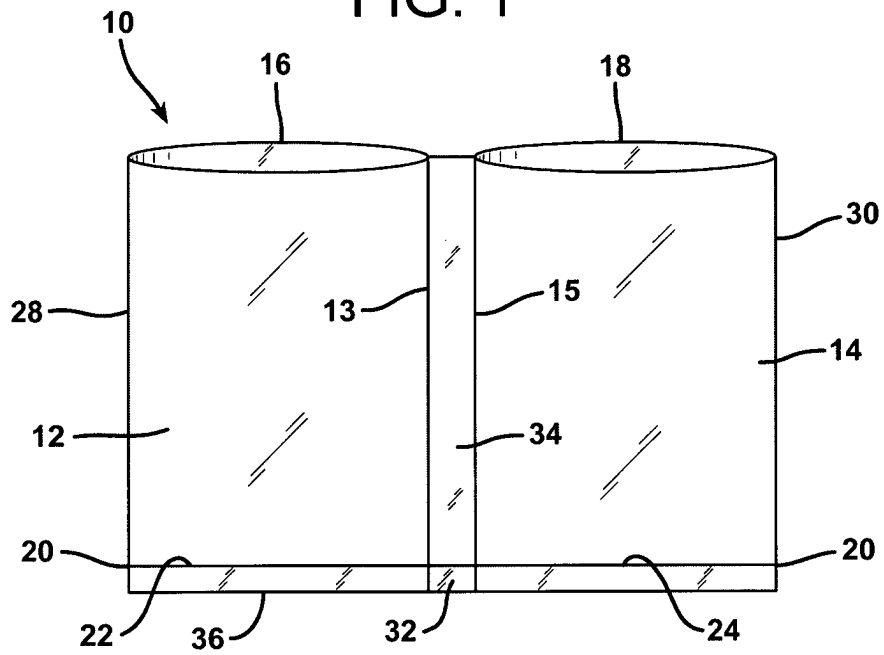

FIG. 2

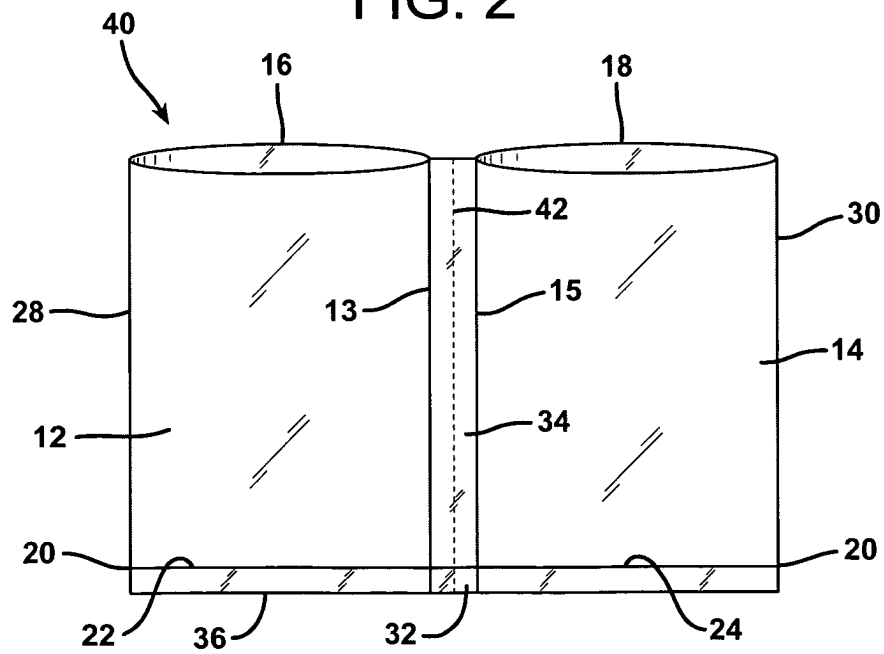

FIG. 3

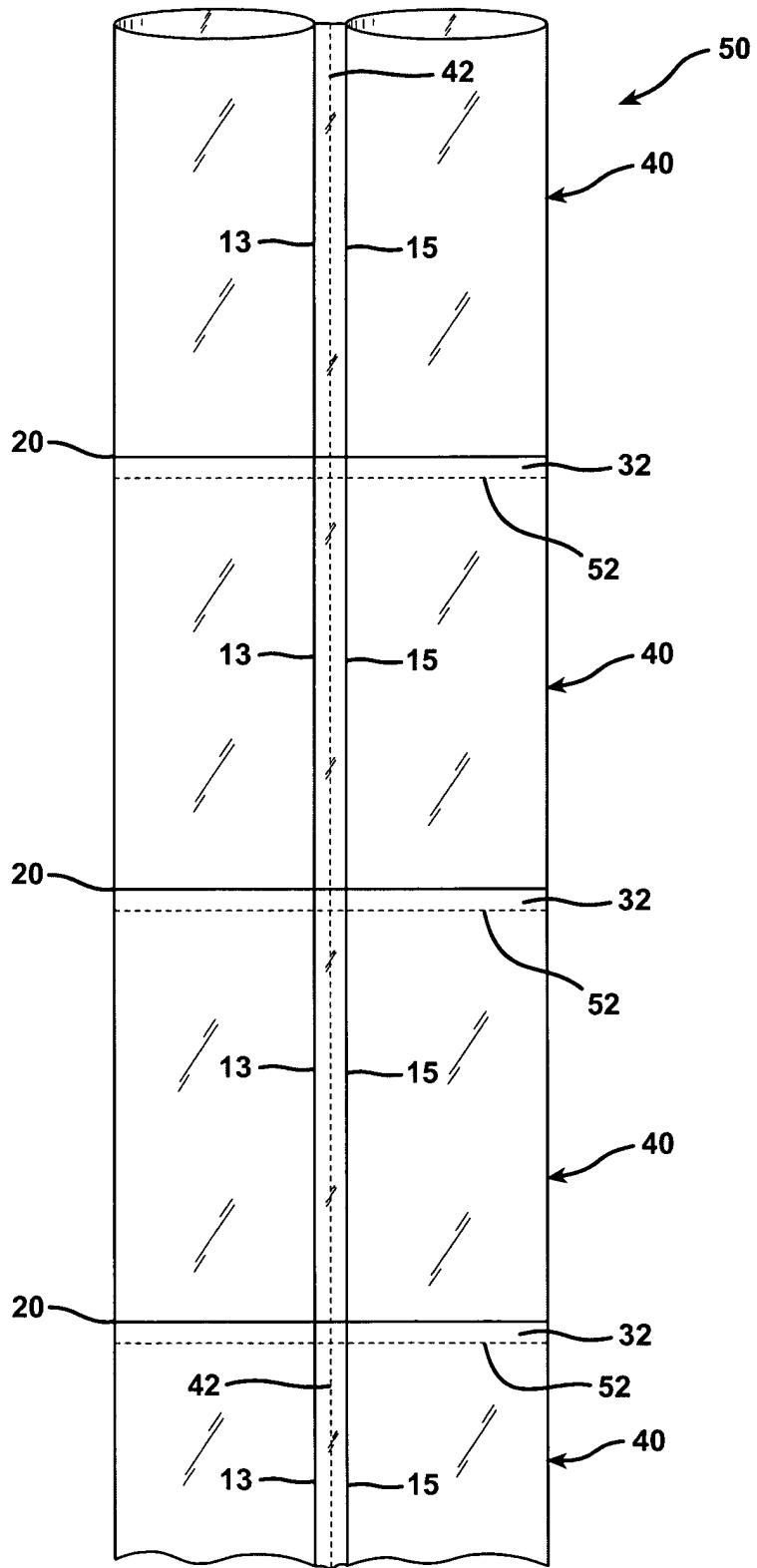

FIG. 4

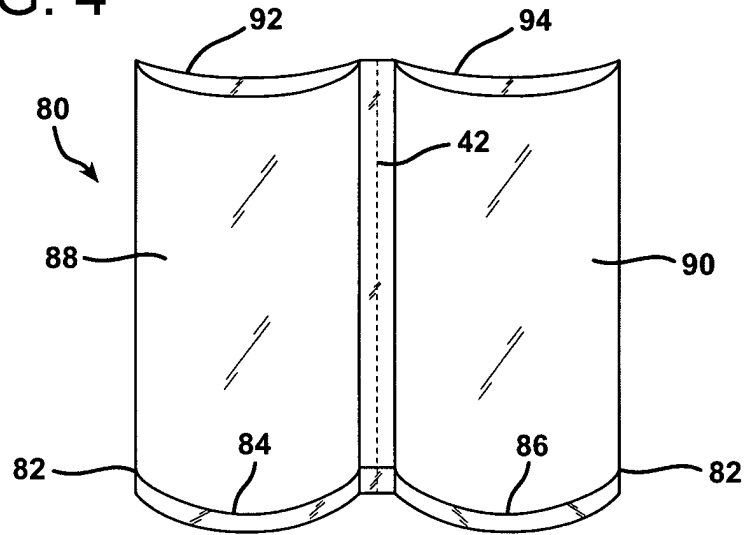

FIG. 5

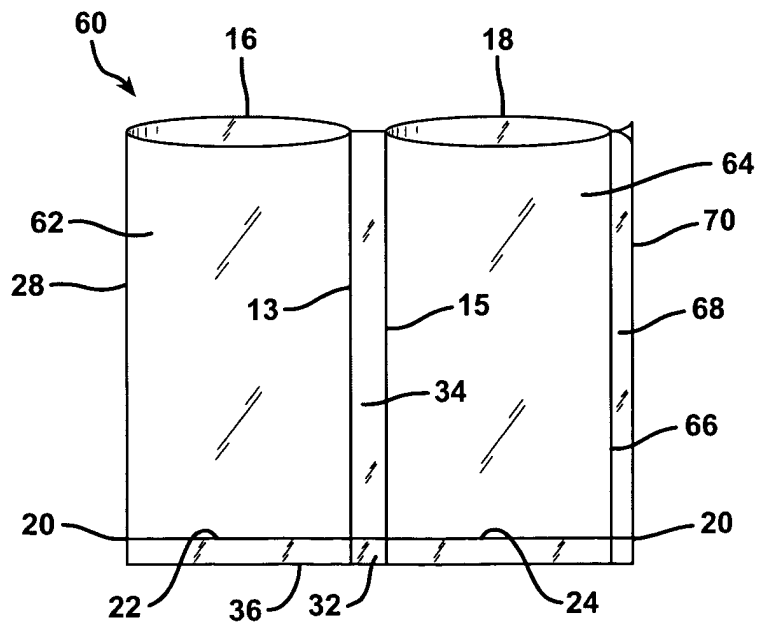

FIG. 6

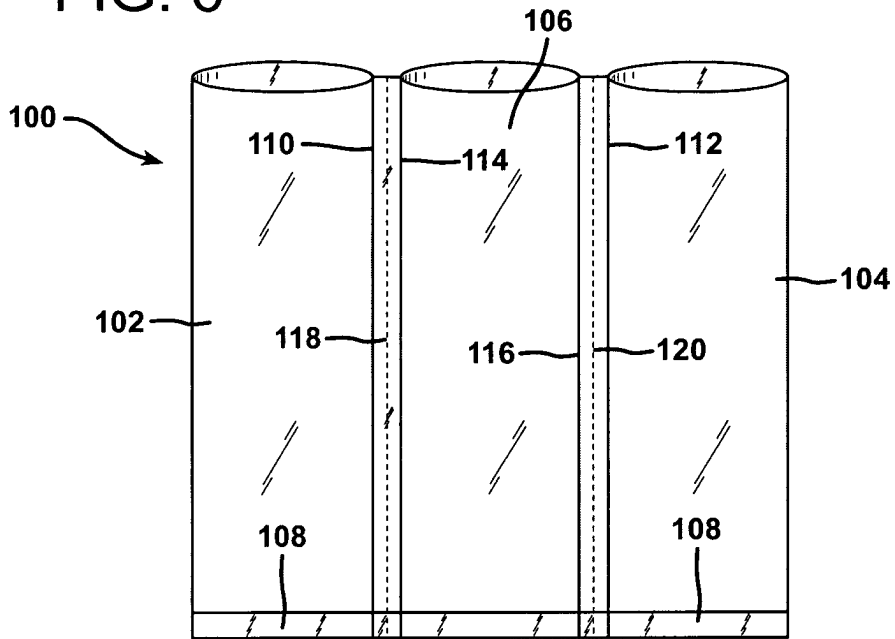

FIG. 7

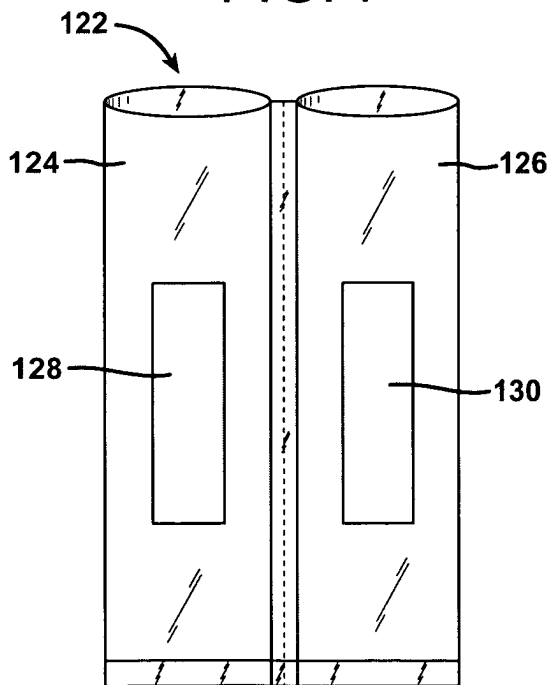

FIG. 9

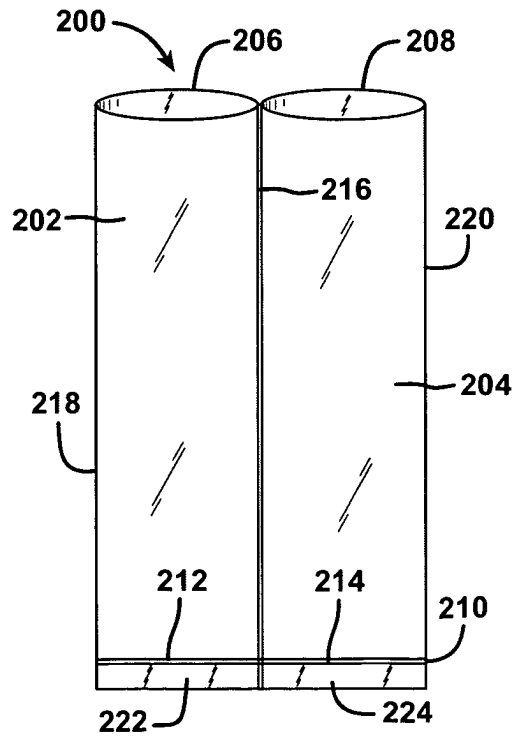
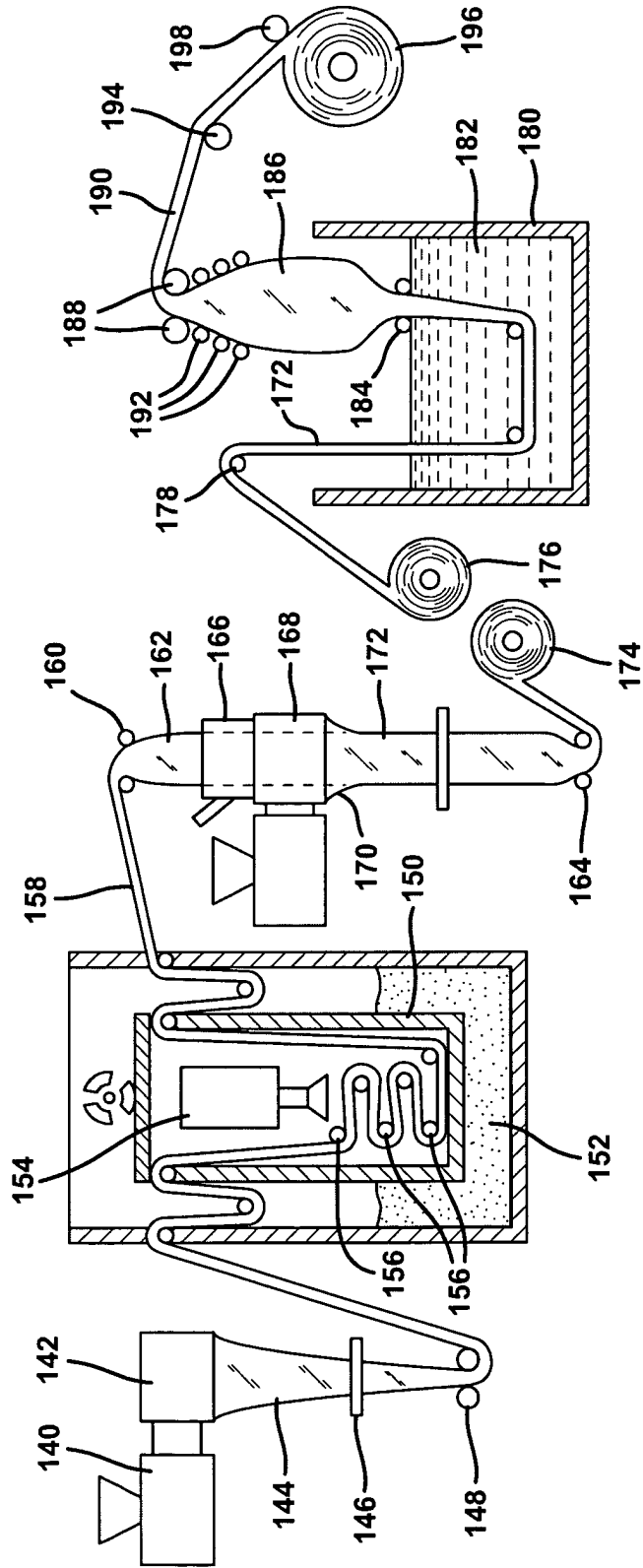

FIG. 8





DOCUMENTS CONSIDERED TO BE RELEVANT			
Category	Citation of document with indication, where appropriate, of relevant passages	Relevant to claim	CLASSIFICATION OF THE APPLICATION (Int.Cl.7)
Y	DE 90 06 144 U1 (CARL FRIED. MUELLER AG, 7100 HEILBRONN, DE) 2 August 1990 (1990-08-02) * page 4, line 24 - page 5, line 15 *	1-25	B65D75/42 B65D33/00
X	* page 6, lines 15-33 * * figures *	16-19	
Y	----- US 2001/046536 A1 (NOEL DAVID C ET AL) 29 November 2001 (2001-11-29) * paragraphs [0039], [0040]; figures *	1-25	
X	----- US 2 805 814 A (CALASIBETTA JOHN ET AL) 10 September 1957 (1957-09-10) * the whole document *	25 1-24	
A	----- US 5 834 077 A (BABROWICZ ET AL) 10 November 1998 (1998-11-10) * column 5, line 16 - column 8, line 25 *	1,3,10, 13,14, 20,21	
A	----- GB 2 128 575 A (W R * GRACE & CO) 2 May 1984 (1984-05-02) * page 2, lines 4-63; figures 1,2a,2b *	1-25	TECHNICAL FIELDS SEARCHED (Int.Cl.7) B65D
A	----- GB 937 956 A (THE PAUL MOORE COMPANY LIMITED) 25 September 1963 (1963-09-25) * page 2, lines 74-99; figure 3 *	1-25	
A	----- US 2 754 644 A (VERGOBBI ROBERT W ET AL) 17 July 1956 (1956-07-17) * figures 11,12 *	1,16,20	
The present search report has been drawn up for all claims			
Place of search Munich		Date of completion of the search 14 March 2005	Examiner Philippon, D
CATEGORY OF CITED DOCUMENTS X : particularly relevant if taken alone Y : particularly relevant if combined with another document of the same category A : technological background O : non-written disclosure P : intermediate document		T : theory or principle underlying the invention E : earlier patent document, but published on, or after the filing date D : document cited in the application L : document cited for other reasons ----- & : member of the same patent family, corresponding document	

1
EPO FORM 1503 03.82 (P04C01)

**ANNEX TO THE EUROPEAN SEARCH REPORT
ON EUROPEAN PATENT APPLICATION NO.**

EP 04 02 9330

This annex lists the patent family members relating to the patent documents cited in the above-mentioned European search report. The members are as contained in the European Patent Office EDP file on
The European Patent Office is in no way liable for these particulars which are merely given for the purpose of information.

14-03-2005

Patent document cited in search report		Publication date	Patent family member(s)	Publication date
DE 9006144	U1	02-08-1990	NONE	

US 2001046536	A1	29-11-2001	AU 762118 B2	19-06-2003
			AU 4703799 A	10-01-2000
			CA 2335552 A1	29-12-1999
			EP 1089921 A1	11-04-2001
			NZ 508943 A	31-10-2003
			WO 9967153 A1	29-12-1999
			US 2001051200 A1	13-12-2001

US 2805814	A	10-09-1957	NONE	

US 5834077	A	10-11-1998	AT 192694 T	15-05-2000
			AT 262414 T	15-04-2004
			AU 702611 B2	25-02-1999
			AU 3299695 A	18-04-1996
			BR 9504273 A	01-10-1996
			CA 2159792 A1	05-04-1996
			DE 69516796 D1	15-06-2000
			DE 69516796 T2	16-11-2000
			DE 69532774 D1	29-04-2004
			EP 0707957 A1	24-04-1996
			EP 0976547 A2	02-02-2000
			ES 2216400 T3	16-10-2004
			JP 8187814 A	23-07-1996
			NZ 280151 A	19-12-1997
			US 5837335 A	17-11-1998

GB 2128575	A	02-05-1984	CA 1205050 A1	27-05-1986
			AU 562213 B2	04-06-1987
			AU 1784083 A	12-04-1984
			BE 897892 A1	16-01-1984
			DE 3336095 A1	05-04-1984
			DK 454083 A	05-04-1984
			FR 2533893 A1	06-04-1984
			IT 1166976 B	06-05-1987
			JP 59084751 A	16-05-1984
			MX 172093 B	02-12-1993
			NL 8302974 A	01-05-1984
			NZ 205128 A	20-02-1987
			SE 457527 B	09-01-1989
			SE 8304495 A	05-04-1984

GB 937956	A	25-09-1963	NONE	

US 2754644	A	17-07-1956	NONE	

EPO FORM P0459

For more details about this annex : see Official Journal of the European Patent Office, No. 12/82