

(12) PATENT APPLICATION
(19) AUSTRALIAN PATENT OFFICE

(11) Application No. AU 200151875 A1

(54) Title
Water treatment process for thermal heavy oil recovery

(51)⁷ International Patent Classification(s)
E21B 043/24

(21) Application No: **200151875**

(22) Application Date: **2001.05.03**

(30) Priority Data

(31) Number	(32) Date	(33) Country
2305118	2000.05.03	CA
09577822	2000.05.25	US

(43) Publication Date : **2001.11.08**

(43) Publication Journal Date : **2001.11.08**

(71) Applicant(s)
Aqua Pure Ventures Inc.; Alberta Energy Company Ltd.

(72) Inventor(s)
Steve Kresnyak; Alex Braun

(74) Agent/Attorney
ALLENS ARTHUR ROBINSON,GPO BOX 1776Q,MELBOURNE VIC 3001

**THE ABSTRACT IS ON THE FOLLOWING
PAGE(S).**

10001 43731

0002/017

MARKS & CLERK

05 02/01 03:15 FAX 613 230 8821

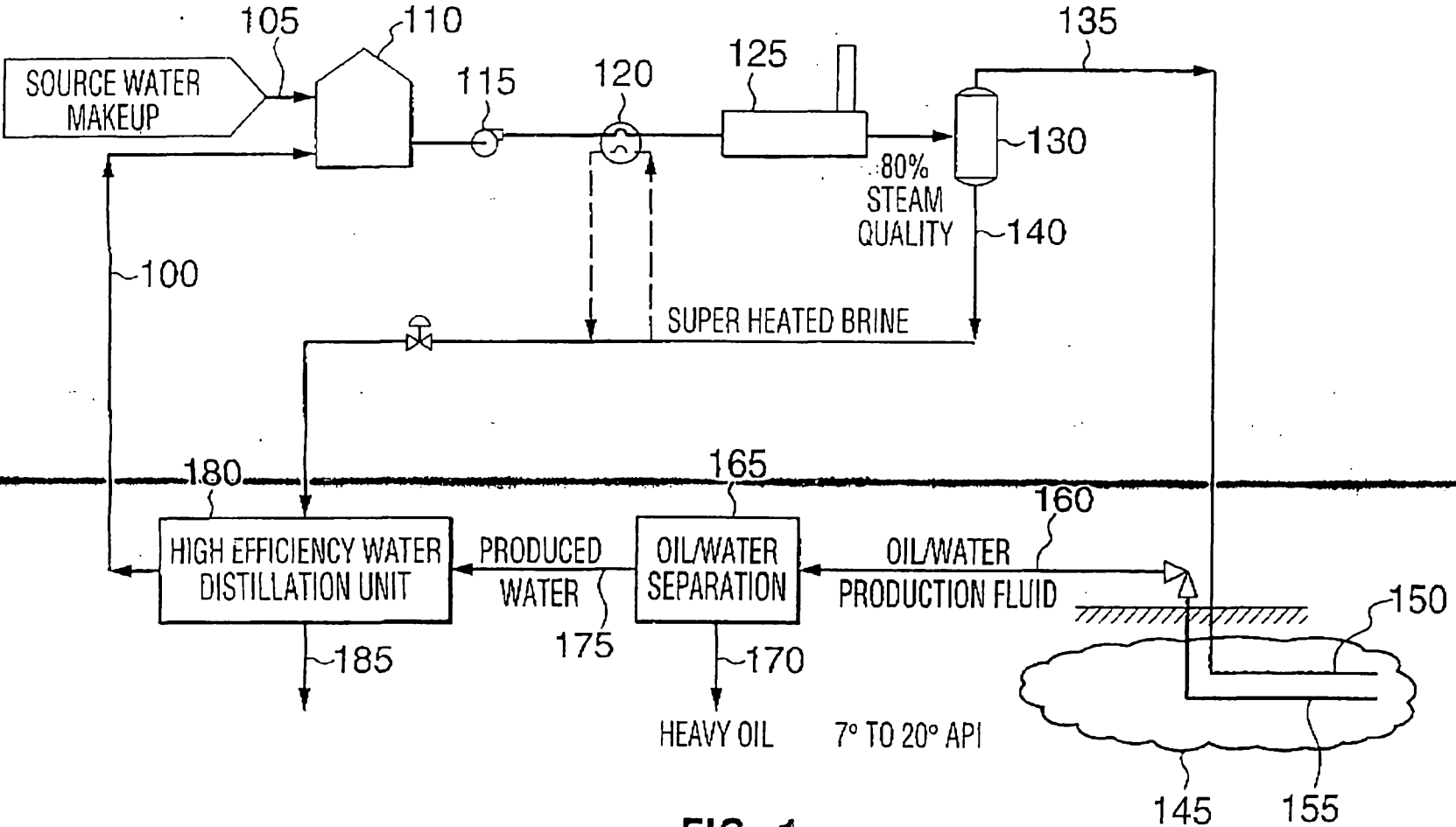

FIG. 1

AUSTRALIA

Patents Act 1990

**ORIGINAL
COMPLETE SPECIFICATION
STANDARD PATENT**

Invention title: Water treatment process for thermal heavy oil recovery

The following statement is a full description of this invention, including the best method of performing it known to us:

030001
553

Water treatment process for thermal heavy oil recovery

This specification comprises and incorporates herein by cross-reference all of the disclosures including the drawings, in each of Canadian patent application no. 2,305,118
5 filed on 3 May 2000 and United States patent application no. 09/577,822 filed on 25 May 2000.

Aqua-Pure Ventures Inc. and Alberta Energy Company Ltd

3 May 2001

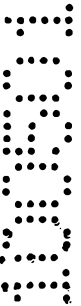
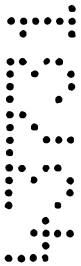

**No claims were lodged
with this application**

10001 43731

0002/017

MARKS & CLERK

05 02/01 03:15 FAX 613 230 8821

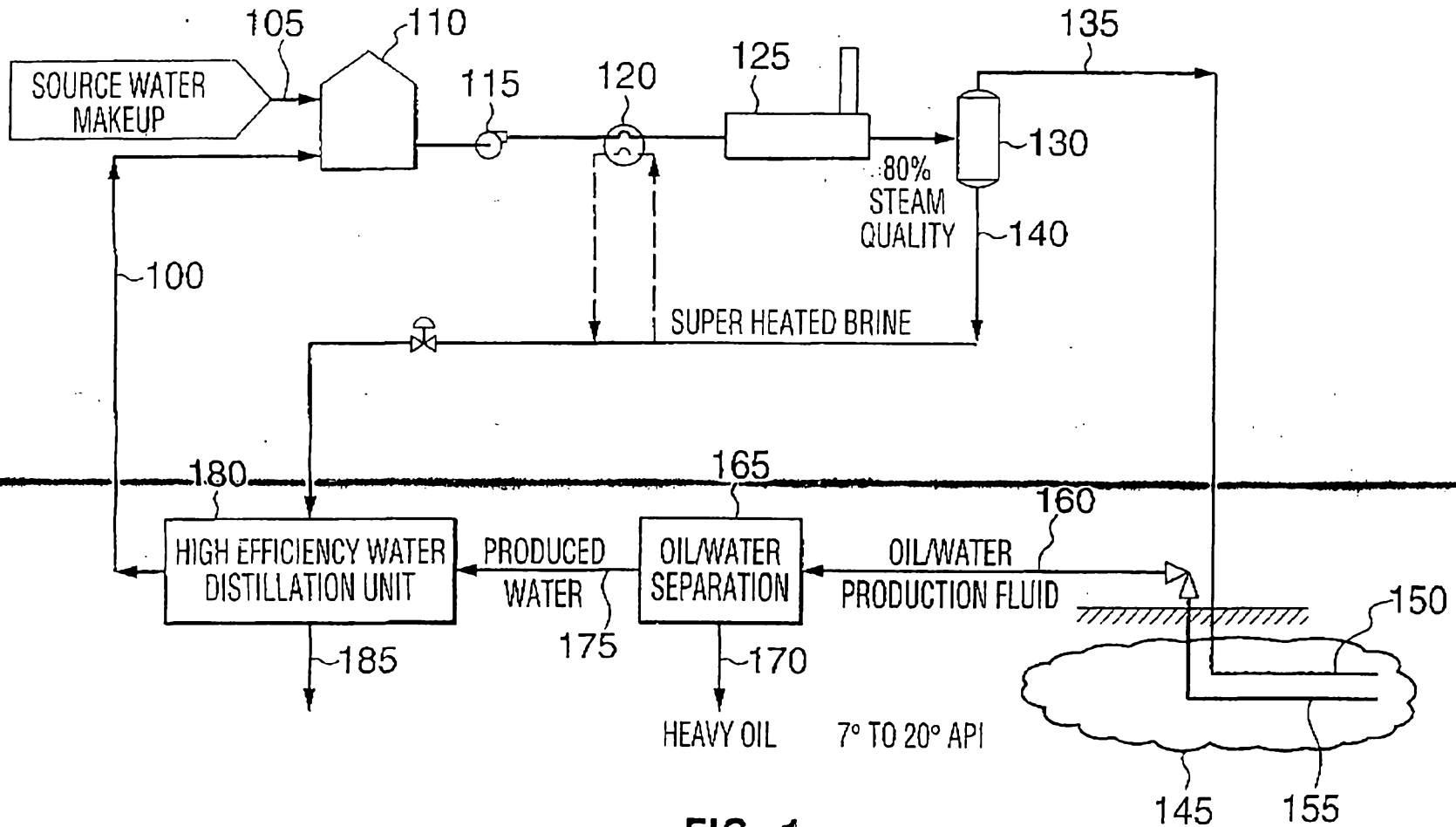

FIG. 1

10501 43731

003/017

MARKS & CLERK

05/02/01 03:15 FAX 613 230 8821

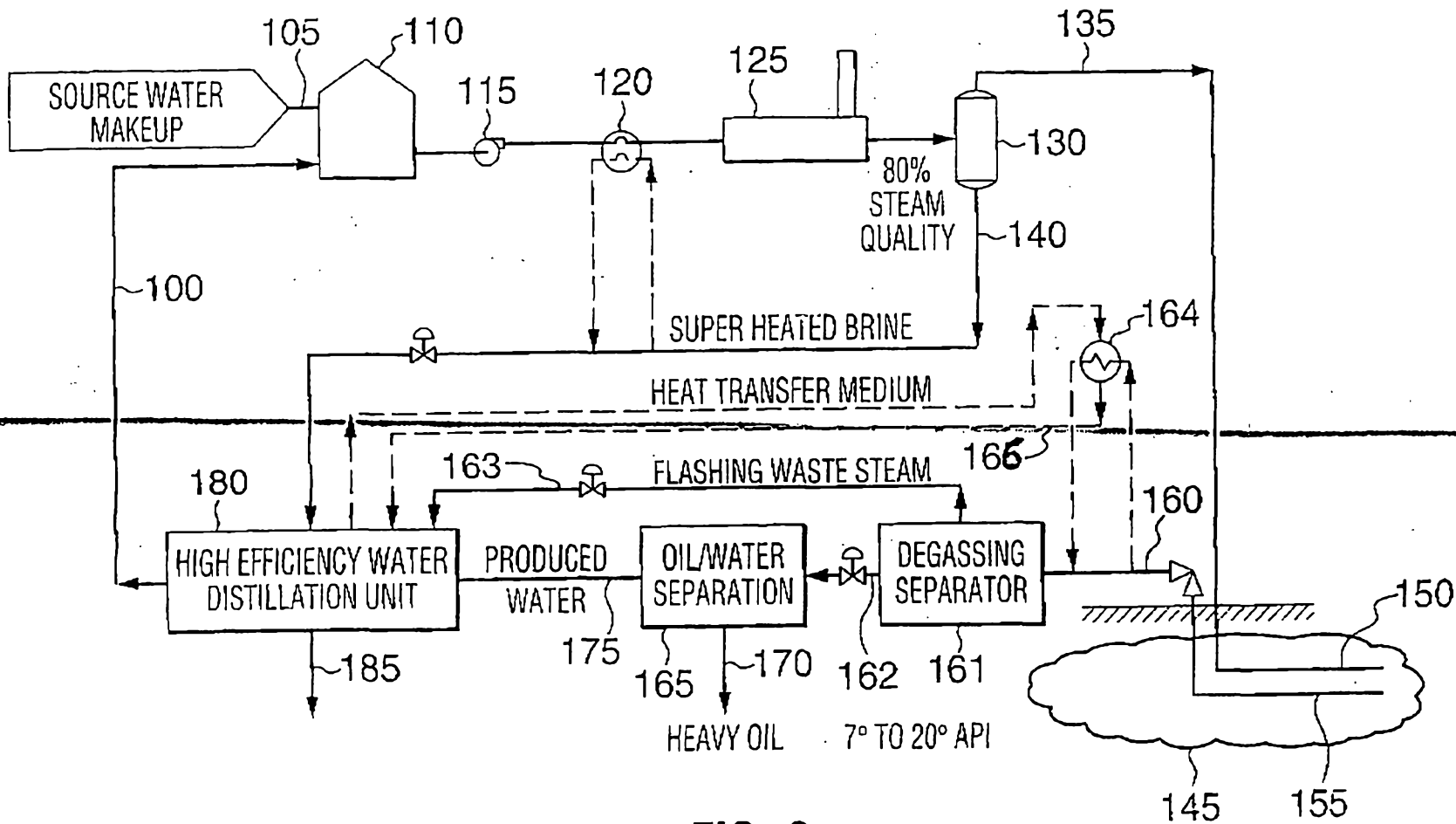

FIG. 2

100501 43731

004/017

MARKS & CLERK

05/02/01 03:15 FAX 613 230 8821

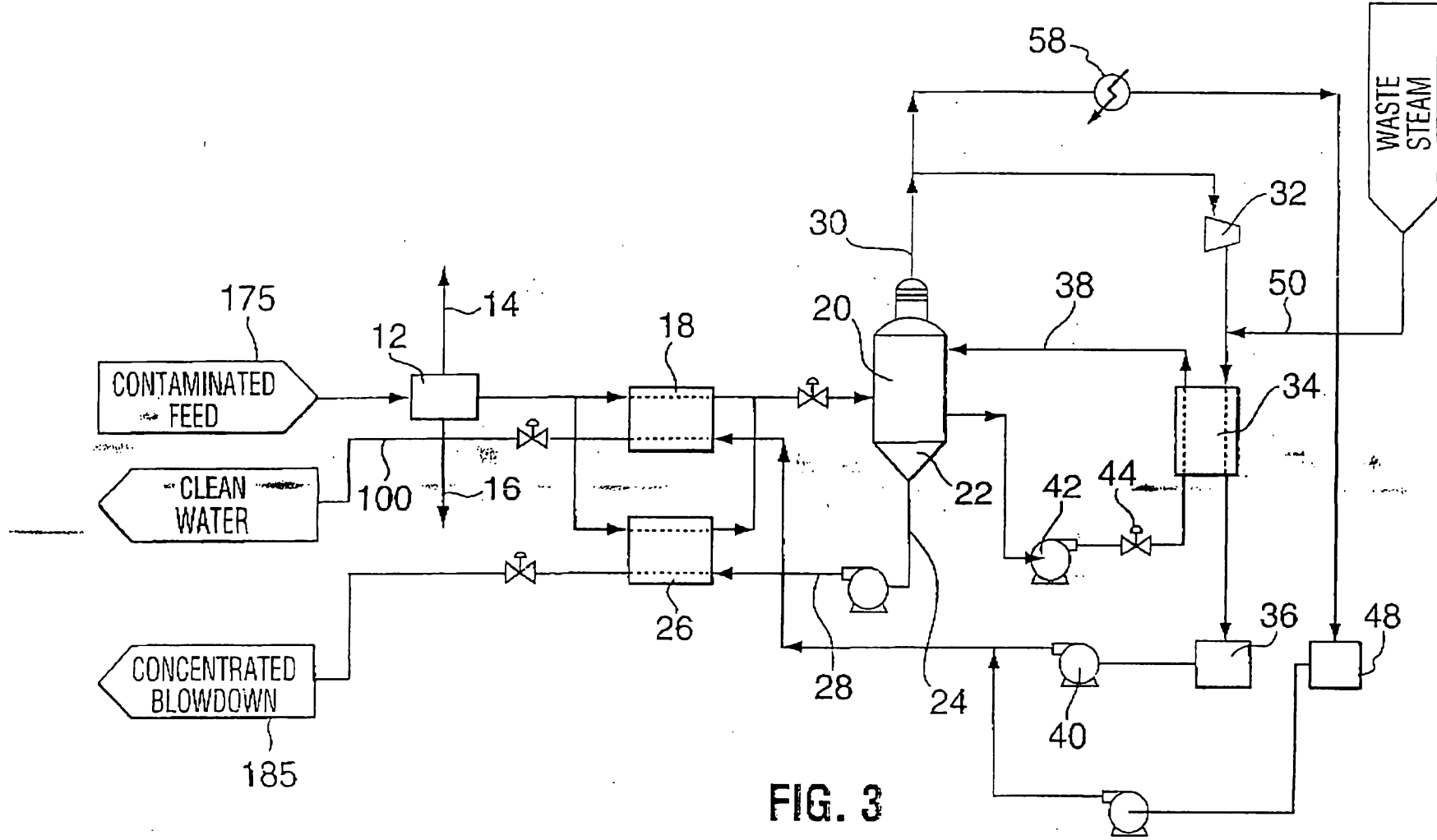

FIG. 3

100501 43731

005.017

MARKS & CLERK

05/02/01 03:15 FAX 613 230 8821

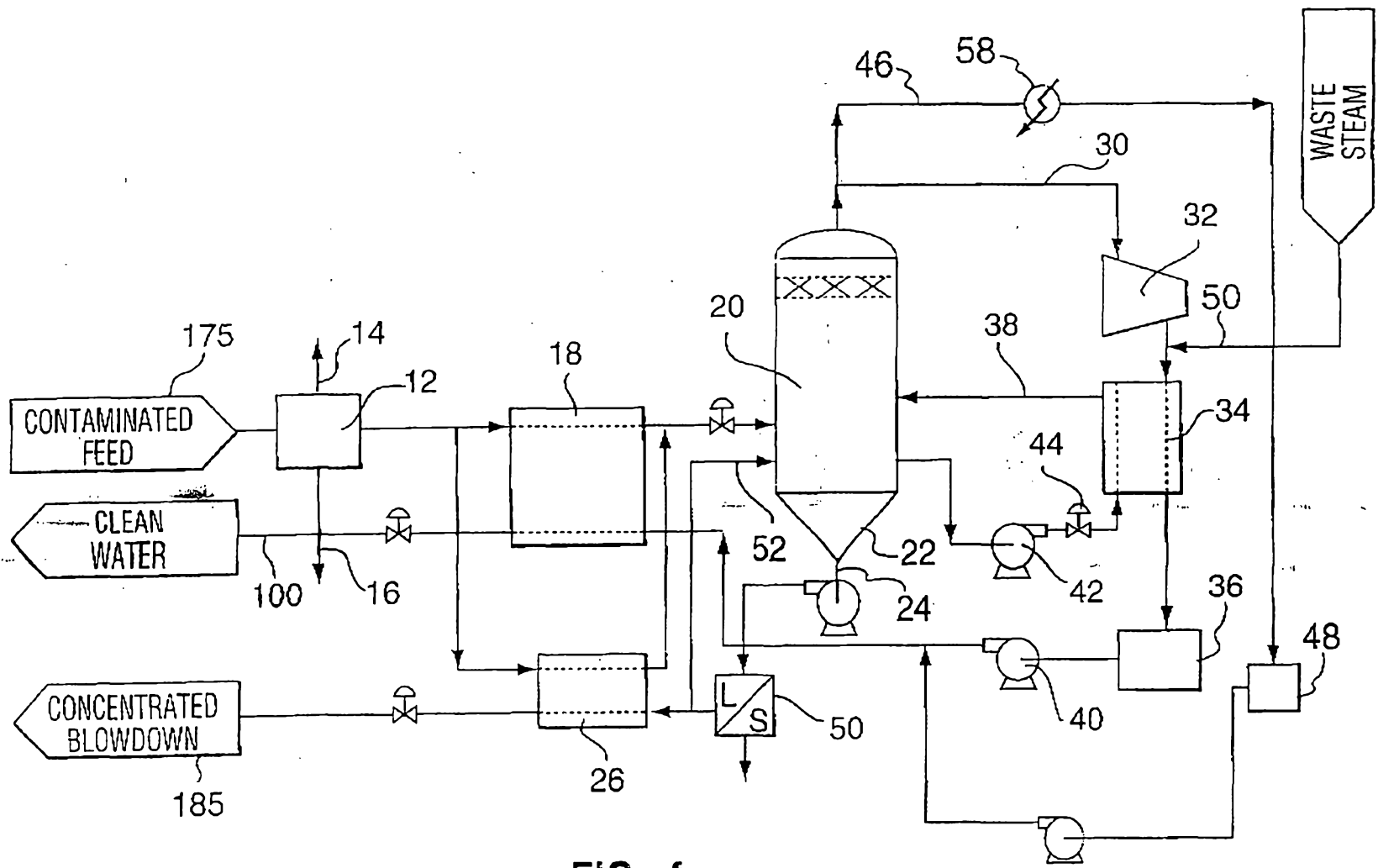

FIG. 4

100901 43701

0006.017

MARKS & CLERK

05.02.01 03:16 FAX 613 230 8821

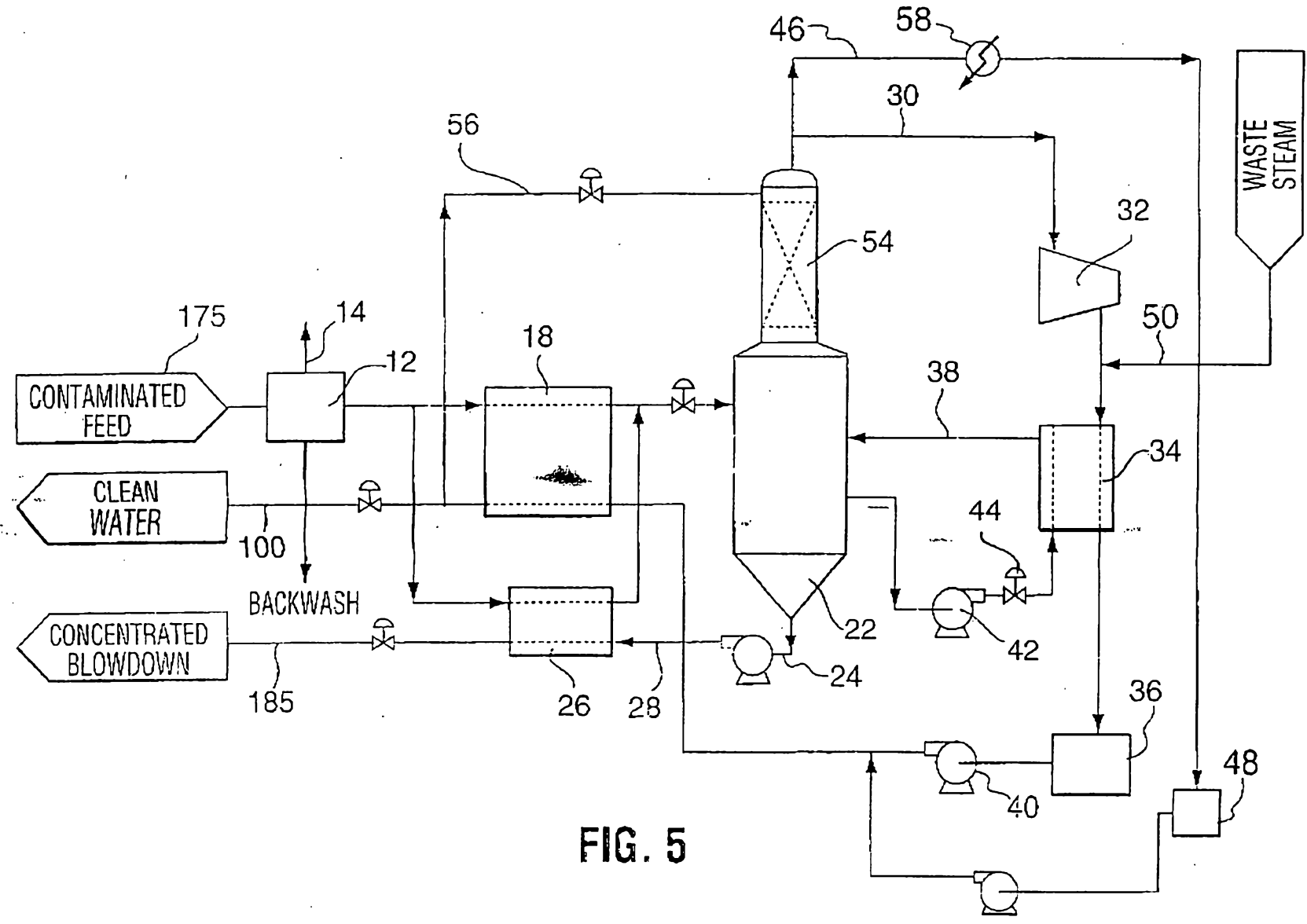
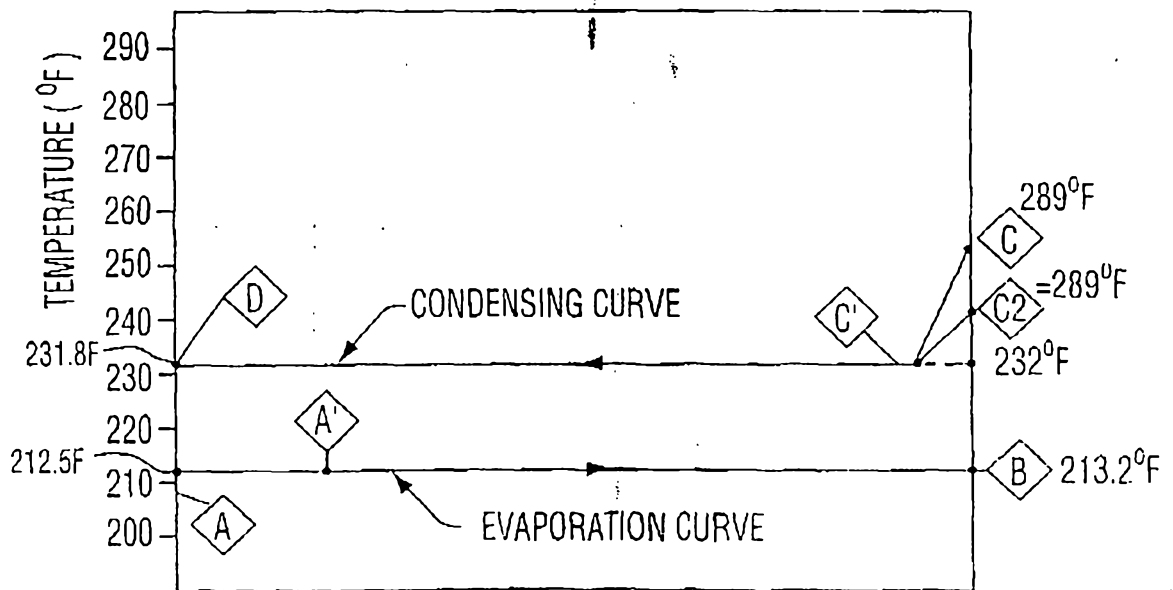
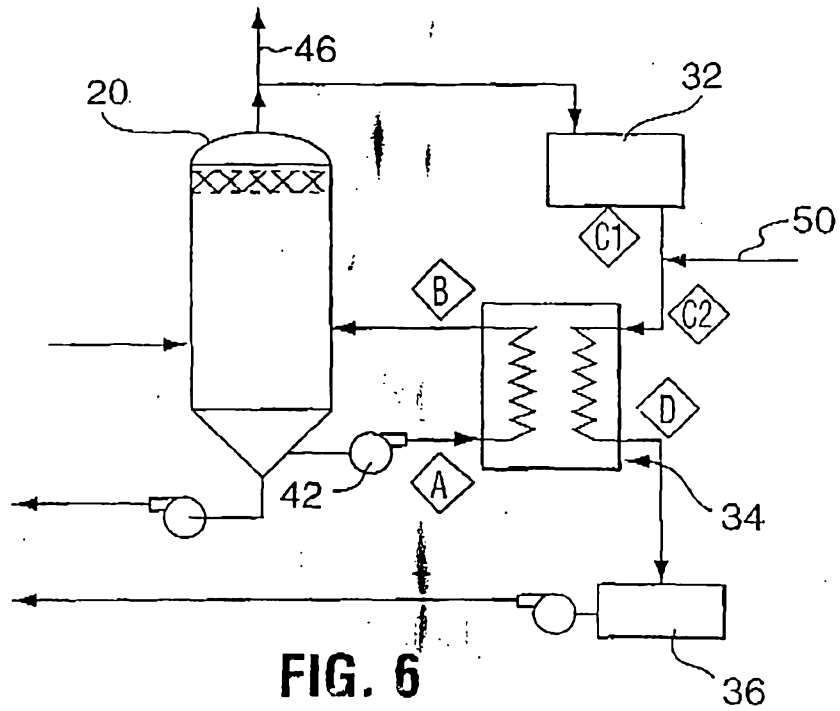

FIG. 5

5000000



WWW.USA1

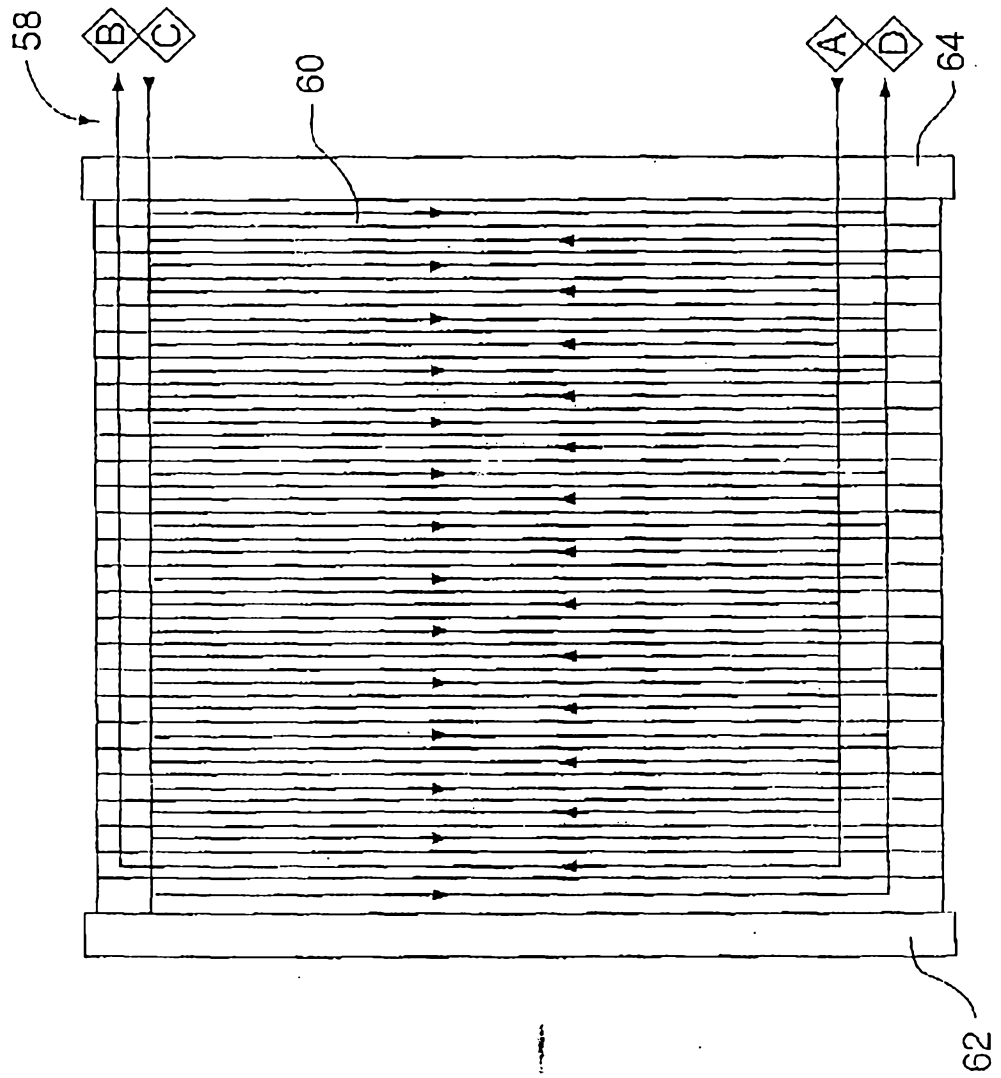

FIG. 8

100801 43701

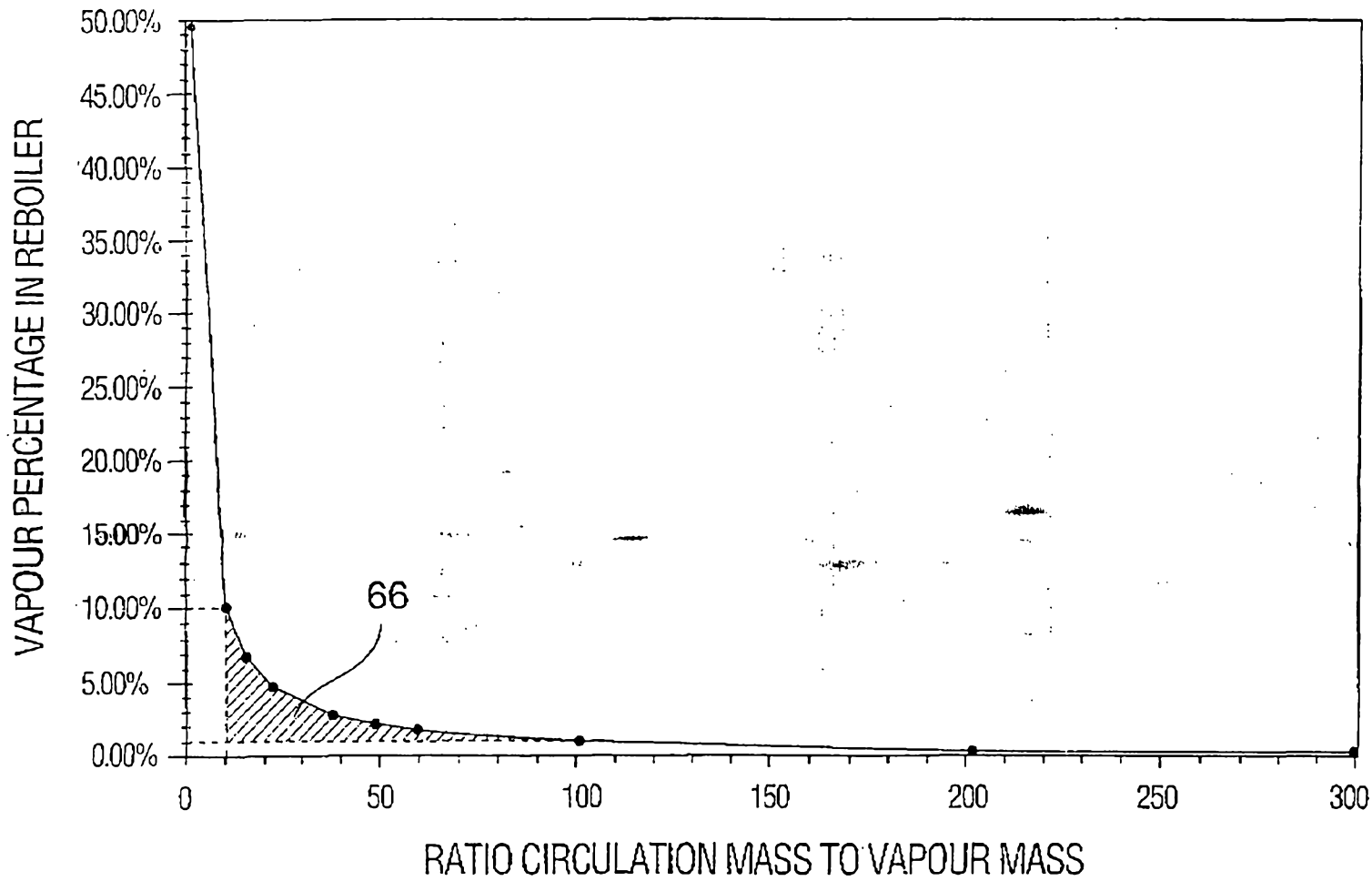

FIG. 9

00501 43701

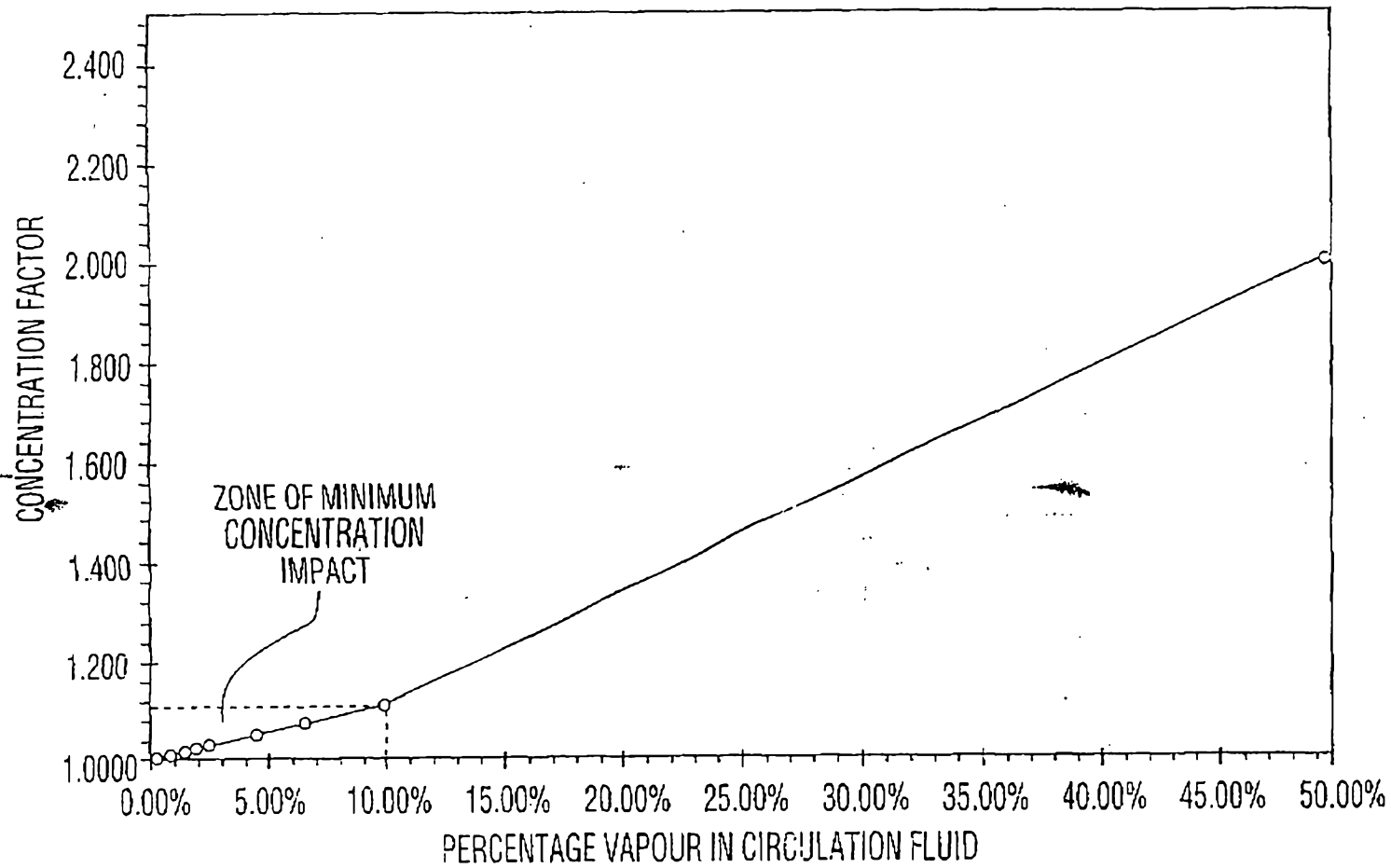

FIG. 10

100901 43701

011/017

MARKS & CLERK

05/02/01 03:17 FAX 613 230 9821

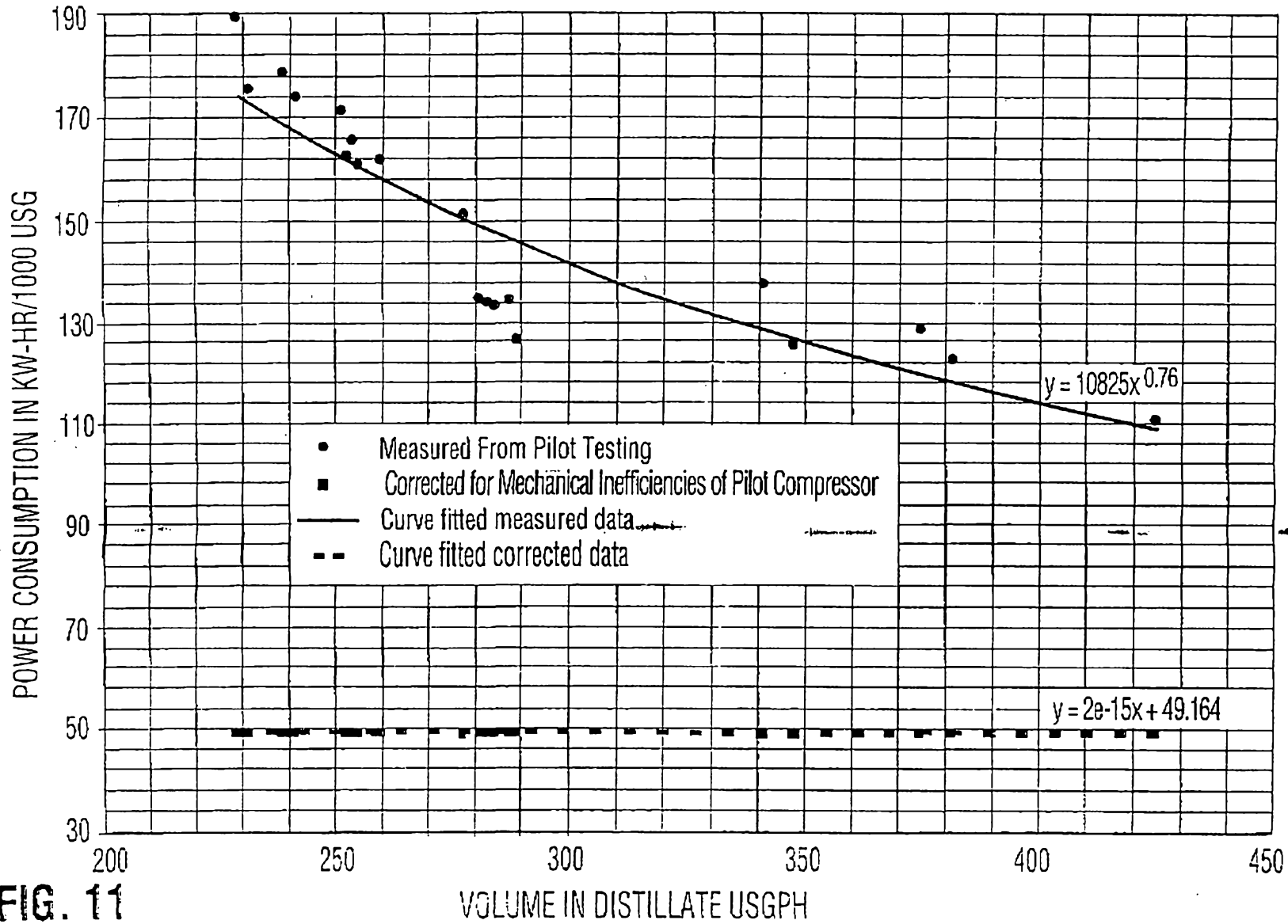

FIG. 11

100501 43701

013/017

MARKS & CLERK

05.02.01 03:18 FAX 613 230 8821

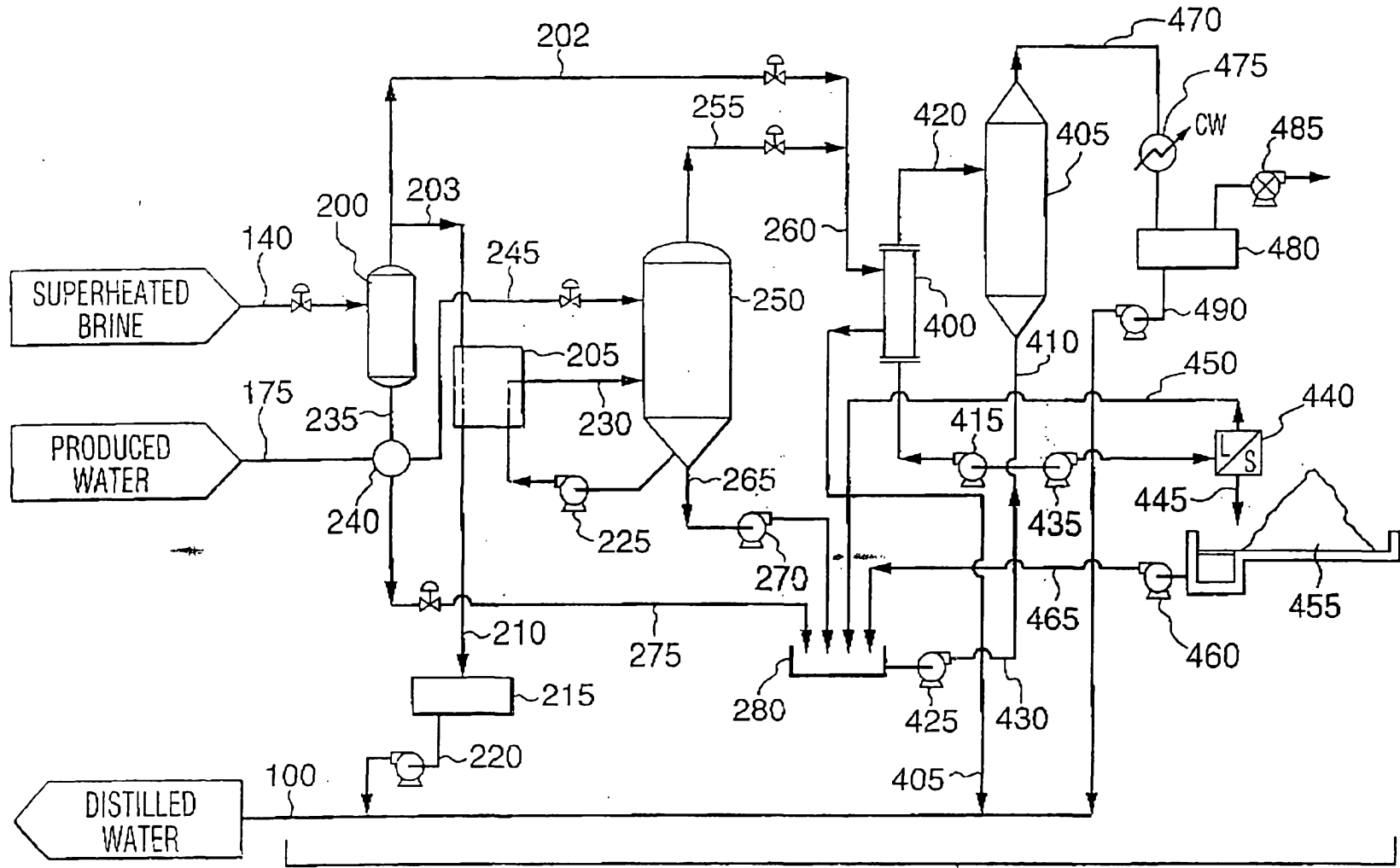

FIG. 13

180

100501 43701

014-017

MARKS & CLERK

05-02-01 03:15 FAX 613 230 6821

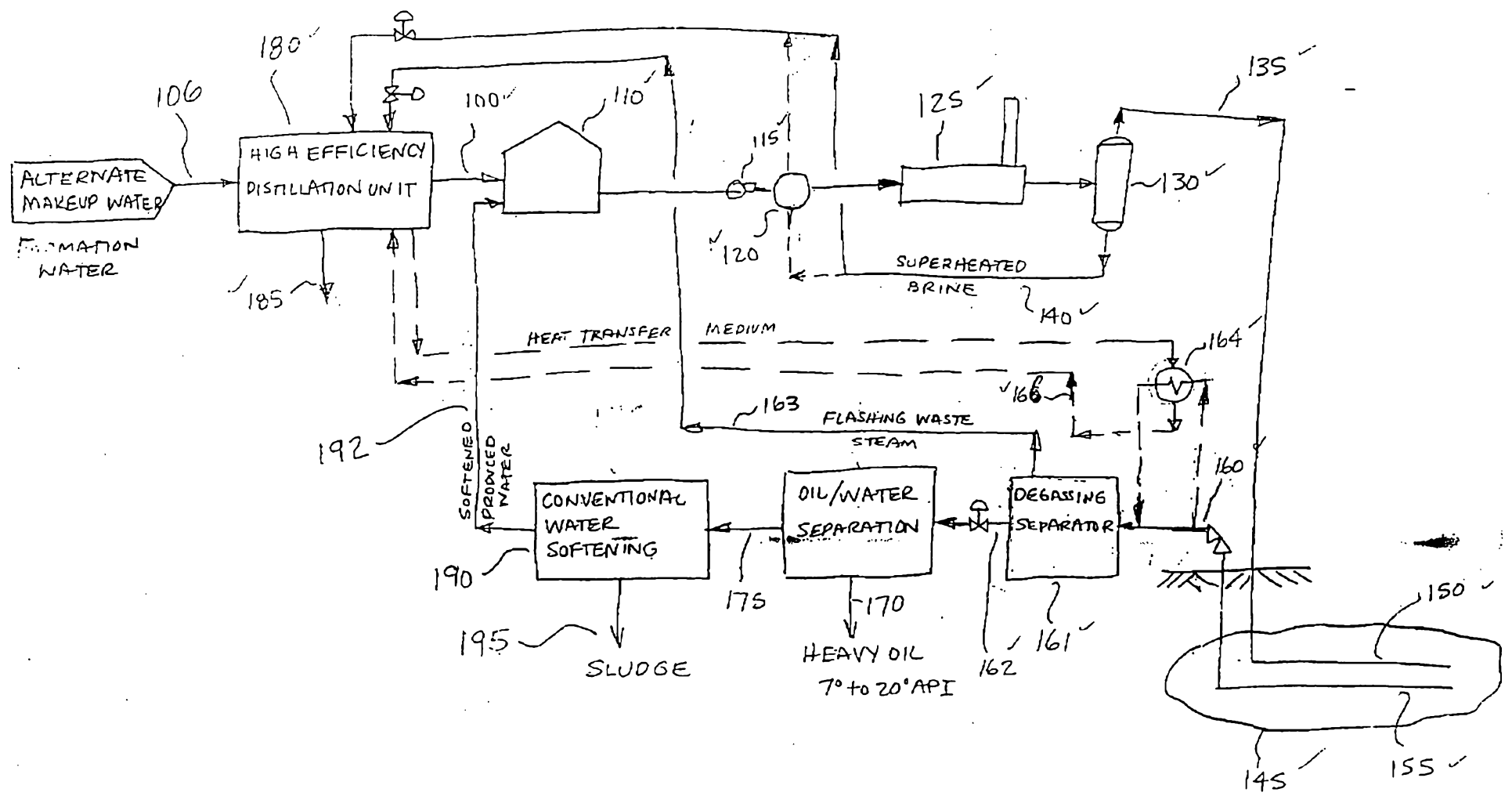

FIGURE 14.

100501 43701

015-017

MARKS & CLERK

05/02/01 03:19 FAX 613 230 8821

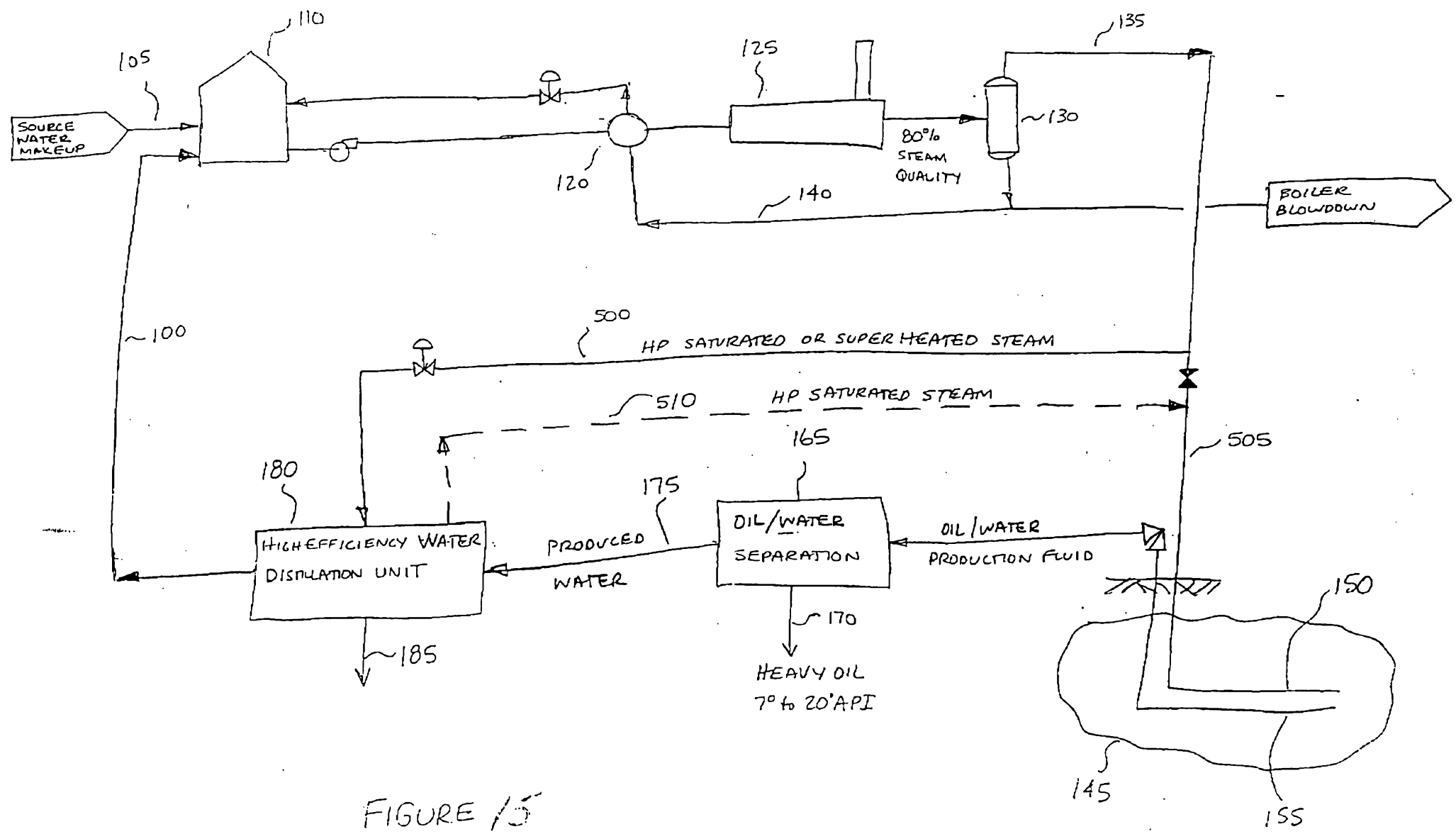

FIGURE 15

100501 43701

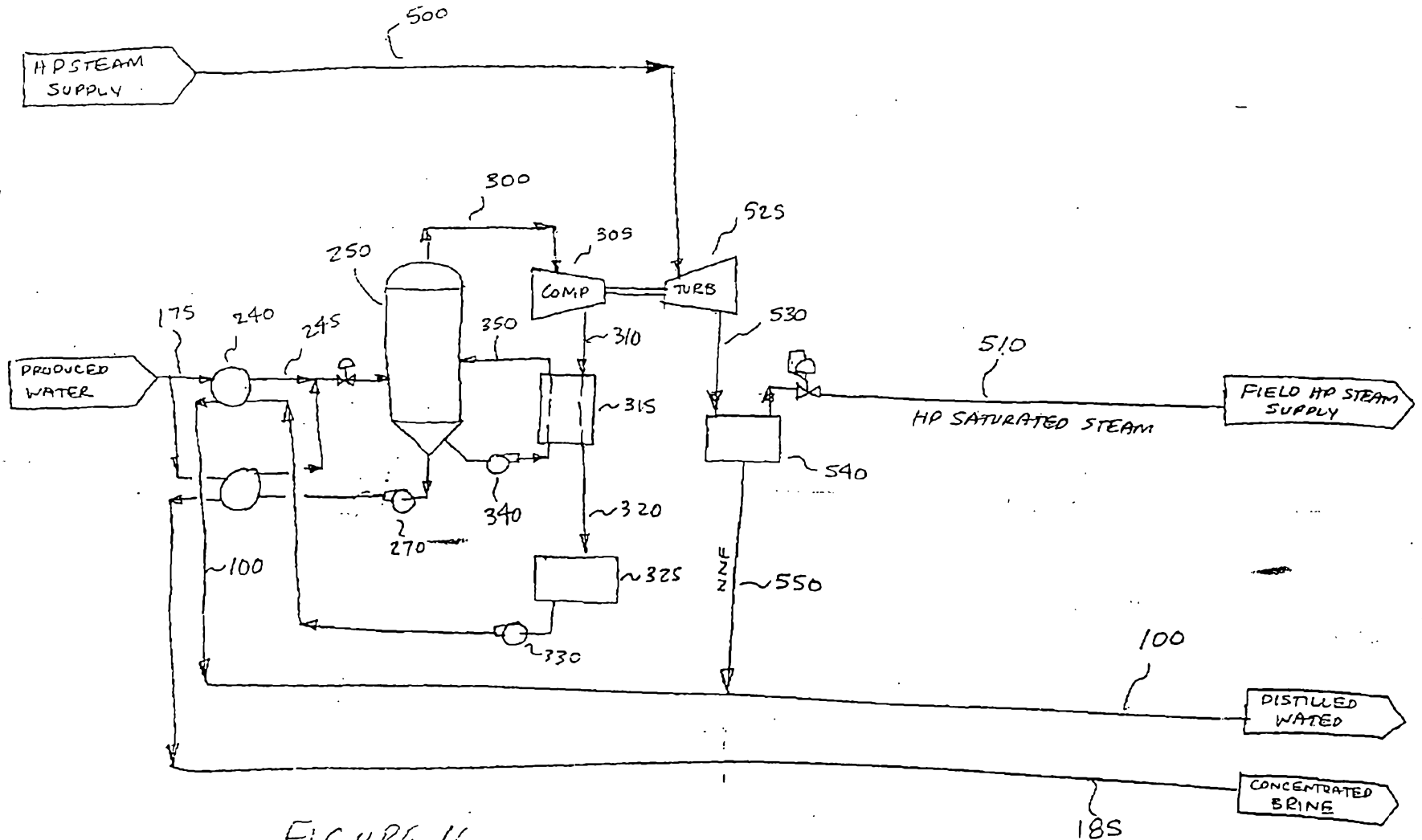

FIGURE 16

016/017

MARKS & CLERK

05/02/01 03:19 FAX 613 230 8521

10501 4371

017-017

MARKS & CLERK

05-02-01 03:19 FAX 013 230 8821

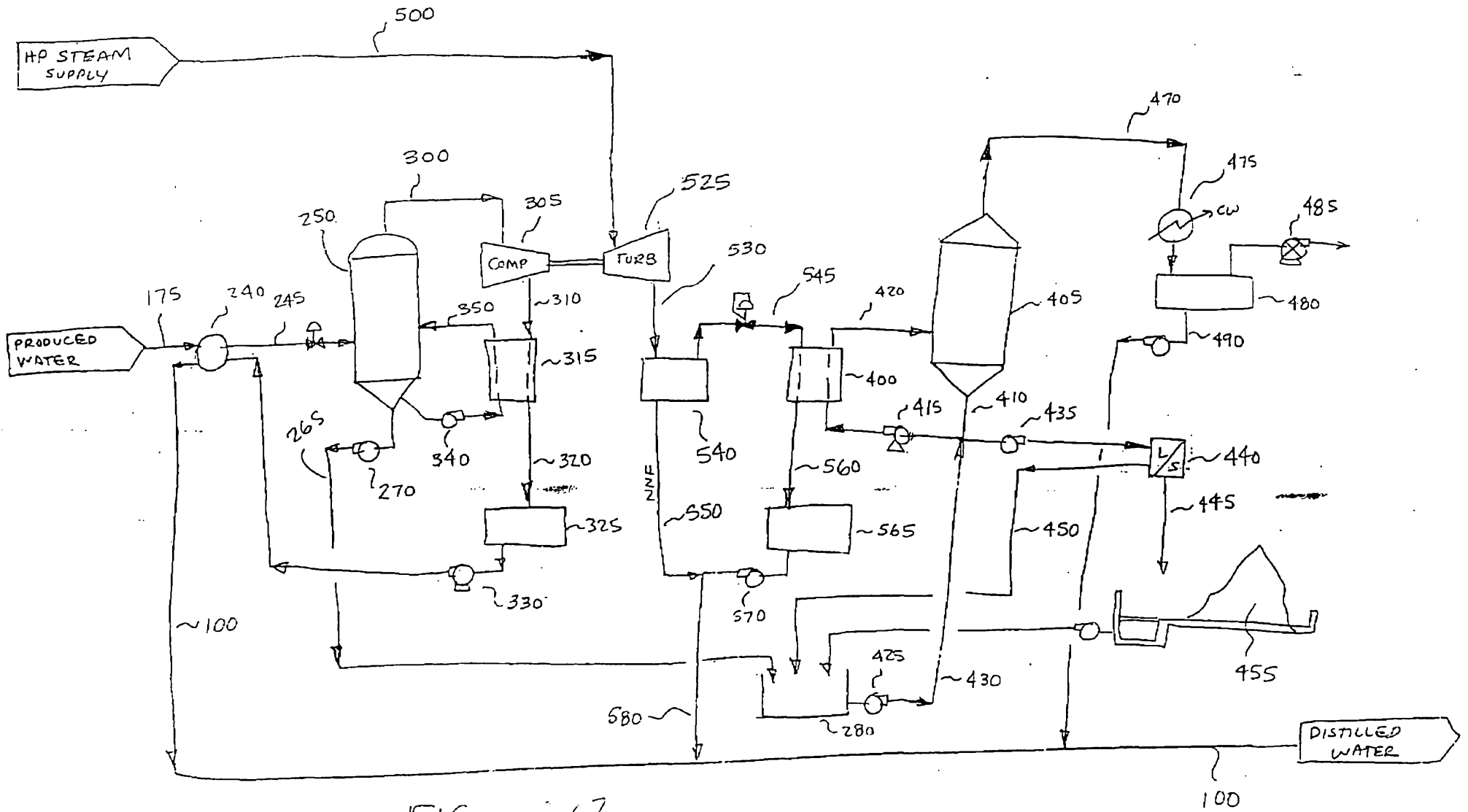

FIG 17