

(12) UK Patent Application (19) GB (11) 2 234 420 (13) A

(43) Date of A publication 06.02.1991

(21) Application No 8917641.6

(22) Date of filing 02.08.1989

(71) Applicant
Michael James Borja
43 Cambridge Street, Grangetown, Cardiff,
United Kingdom

(72) Inventor
Michael James Borja

(74) Agent and/or Address for Service
Wynne-Jones Laine & James
Morgan Arcade Chambers, 33 St Mary Street,
Cardiff, CF1 2AB, United Kingdom

(51) INT CL⁵
A01K 11/00

(52) UK CL (Edition K)
A1X X3

(56) Documents cited
GB 2054340 A GB 1154388 A GB 0790620 A
GB 0755617 A EP 0070594 A2 EP 0025252 A

(58) Field of search
UK CL (Edition K) A1X
INT CL⁵ A01K

(54) Tattooing device

(57) A tattooing head 10 comprises a support through which are inserted a plurality of needles 12 arranged to define a pattern or design, such as a number or letter, at their tips 13. The needles are retained in the support by a block of epoxy resin 14 and pass through the mouth of a channel holder 15. A device is provided in which the head can be mounted for vibration so that the tips pass through absorbent material 22, which contains ink, and then penetrate the skin.

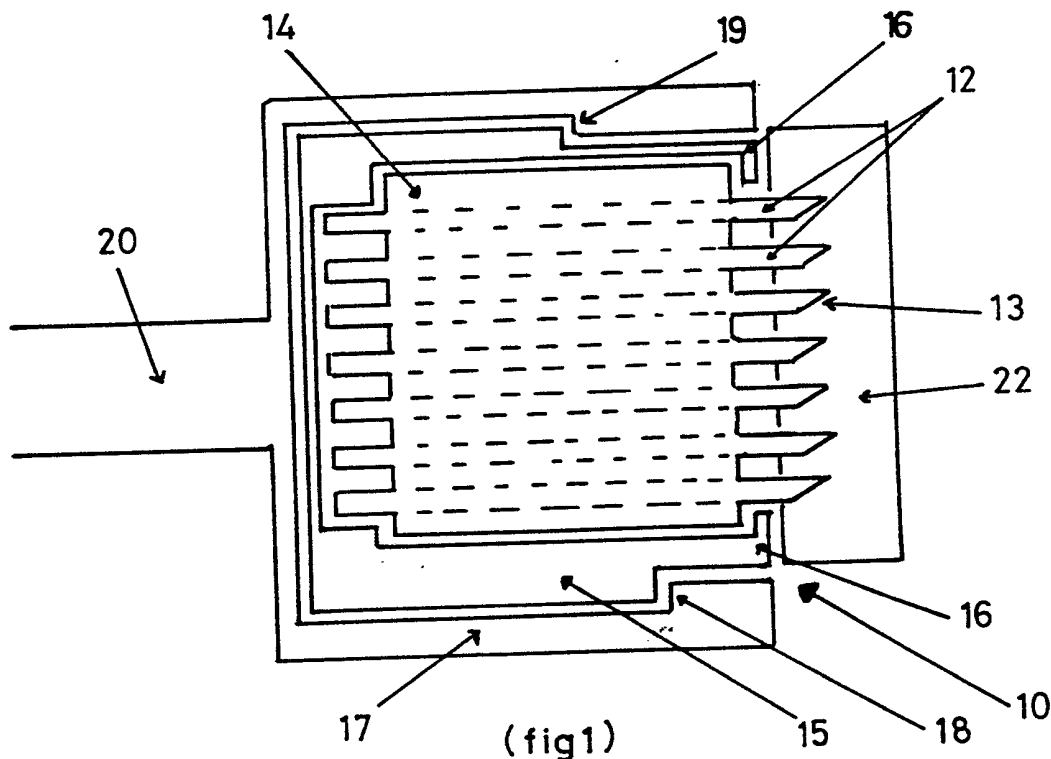

At least one drawing originally filed was informal and the print reproduced here is taken from a later filed formal copy.
The claims were filed later than the filing date within the period prescribed by Rule 25(1) of the Patents Rules 1982.

GB 2 234 420 A

1/2

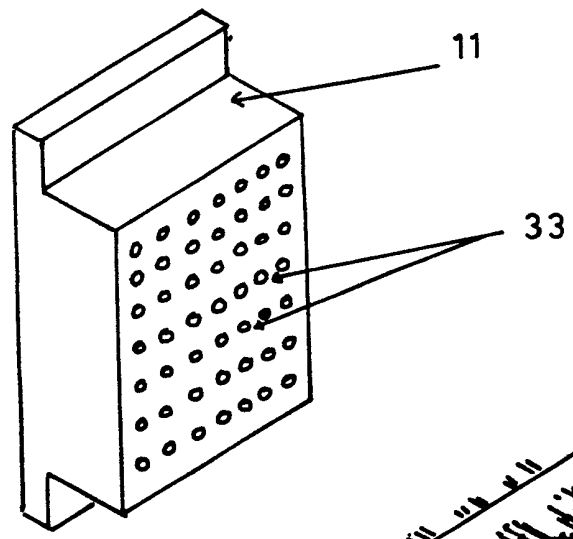
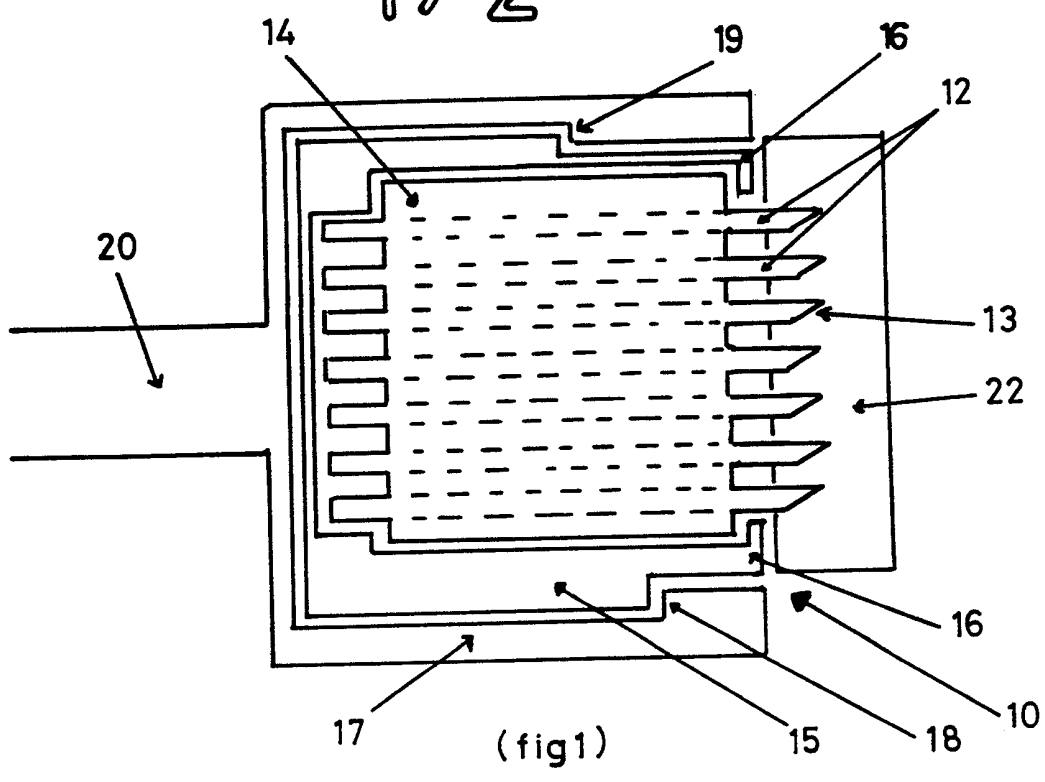

(fig 2)

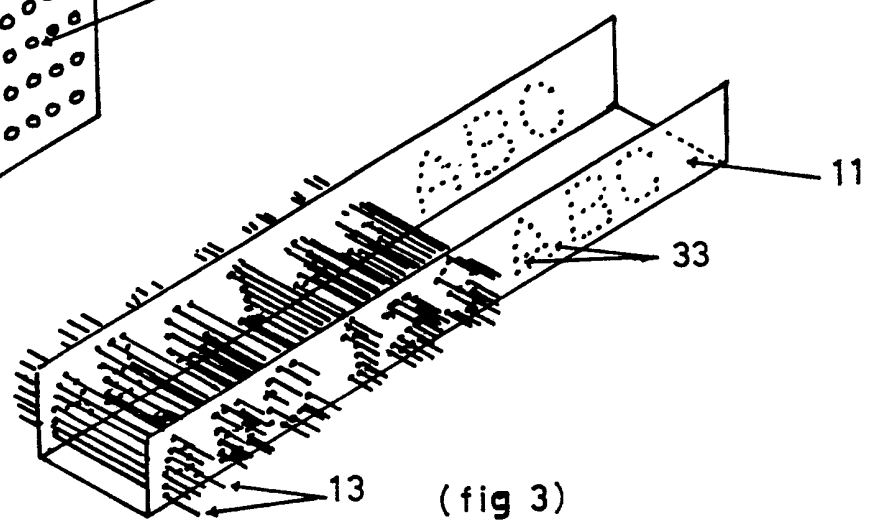

(fig 3)

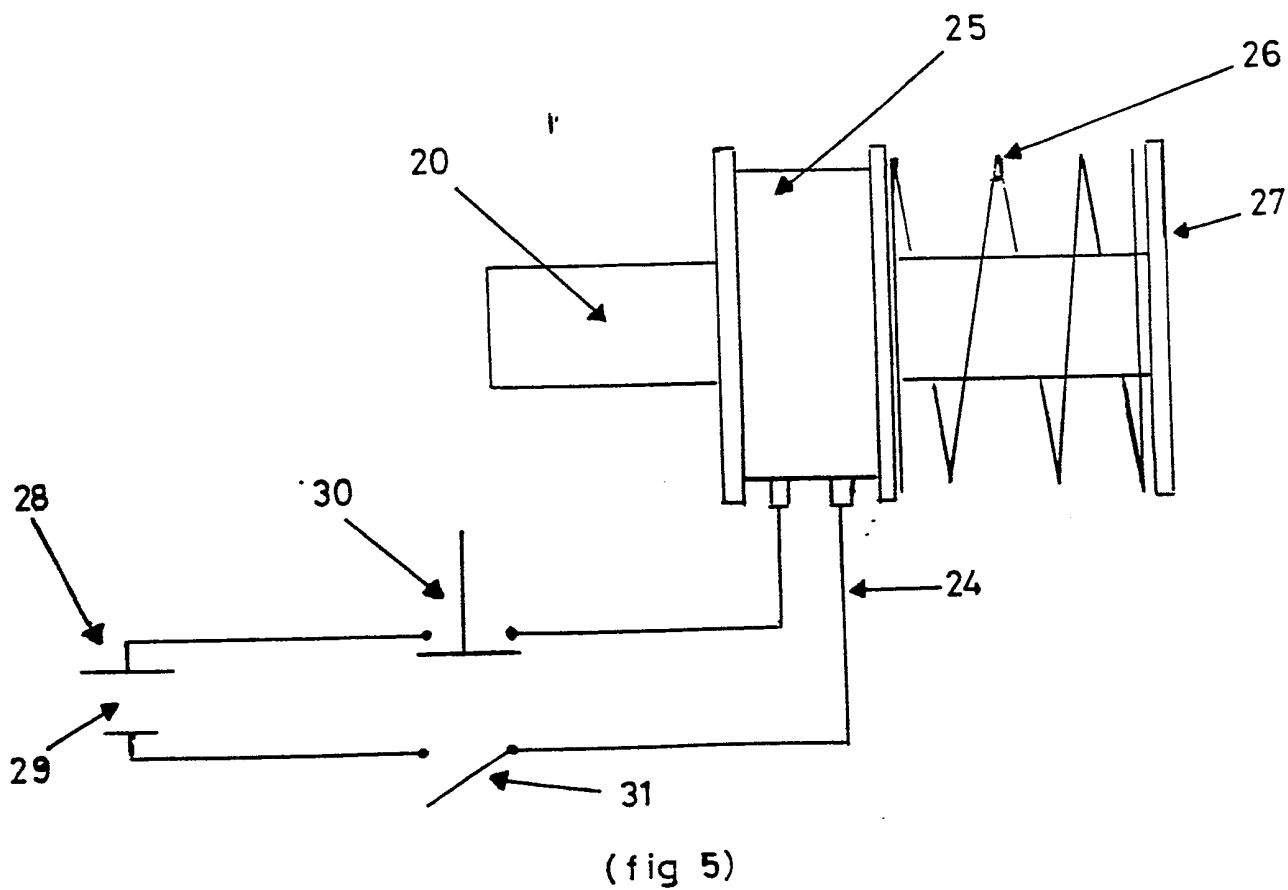
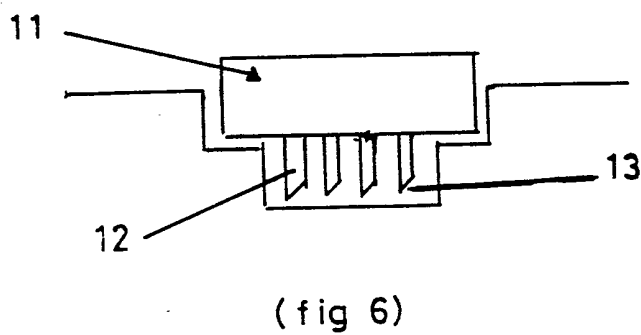
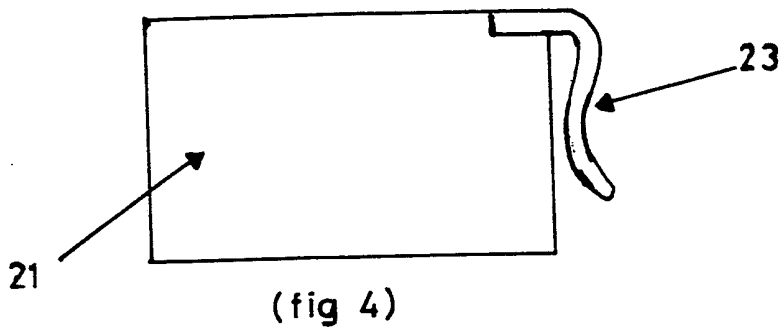

Tattooing Device

This invention relates to tattooing heads, tattooing devices, their method of manufacture and methods of tattooing.

In many agricultural fields it is desirable to be able to permanently mark an animal with an identification specific to that animal. For example cows are quite often marked with ear tags and/or freeze dried brands. There is currently a strong feeling that there should be a dog registration scheme whereby particular animals can be identified as belonging to particular owners, but current forms of marking animals would be unacceptable to most pet owners. Tattooing techniques have existed over many hundreds of years, but they are all somewhat laborious and would represent significant problems for any scheme which was going to be capable of marking seven million or so dogs currently living in the United Kingdom.

From one aspect of the invention there is provided a tattooing head comprising a support and a plurality of needles retained in the support such that their tips define a pattern or design.

Preferably the support is formed as a block or plate having a matrix of holes in which needles can be inserted to form a particular pattern or design. The supports can hold a complete design or each support may provide a particular character such as a number or letter. In this latter case the head may further comprise a holder for retaining a plurality of supports to make up a composite pattern or design.

This holder may be in the form of a channel, with inturned lips, and the supports may be dimensioned to be slidably retained in the holder by the lips with the needles projecting through the mouth of the channel.

The pattern or design may be a number, a letter, a bar code element, a bar code or other identifying symbol or combination thereof.

From another aspect the invention consists in a tattooing device comprising a tattooing head having a plurality of needles, a shaft for supporting the head and an actuator for longitudinally vibrating the shaft, and hence the head, such that the needles penetrate the skin.

The vibration enables the device to deliver several rapid strikes against the skin and hence work the ink into the skin much more quickly than occurs with traditional tattooing techniques.

Preferably an ink pad is mounted on the head such

that the needles pass through the ink pad during vibration by the actuator. This means that they pick up fresh ink between each contact with the skin.

The actuator may be constituted by a solenoid acting on the shaft and means for pulsing the power supplied to the solenoid. Alternatively it may include a motor and a cam mounted for rotation by the motor for engaging the shaft. In either case resilient means are preferably provided for returning the shaft and hence the head to the rest position.

The device may further include a clip or anvil for holding the device in a preset position with respect to a portion of the animal body, for example the ear. This is particularly important when the device is used on a very thin membrane such as constituted by most dogs ears, because the travel of the needles must be sufficient to penetrate the first surface of the skin without passing right through the ear.

From a further aspect of the invention there is provided a method of manufacturing a tattooing head, comprising forming a support having a matrix of holes and inserting a plurality of needles into respective selected holes in the matrix to define a pattern or design. The method may include the step of arranging needles in the pattern or design and this step may be performed by arranging means comprising a matrix of

sheaths into which the needles can be drawn and means for drawing the needles into preselected sheaths. These sheaths could be constituted by the holes of the support of the head defined above. The drawing means may comprise a vacuum source connectable to the sheaths and a mask, apertured to correspond with a particular pattern or design inserted between the vacuum source and the sheaths so that the vacuum source only communicates with selected sheaths. Thus a plurality of masks could be provided corresponding to alpha-numeric characters, bar code elements or the like. Alternatively the drawing means may be magnetic means for forming localised magnetic fields around or in the sheaths.

In one embodiment of the method the needles may be of stainless steel and the support may be of aluminium, in which case relatively cool needles may be inserted into the relatively hot support so that on cooling of the support they are firmly held therein. Alternatively the needles may be set in setting material injected around them.

The method may also include the step of holding the support above a channel during insertion of the needles so that the needle length projecting from the support is defined by the depth of the channel.

The invention includes an apparatus for performing the method of the invention and having the structural

aspects set out above.

From a still further aspect the invention includes a tattooing kit comprising a tattooing device, a tattooing head for tattooing a specific pattern, design and registration papers.

The kit may also comprise an ink body for use with a tattooing head.

In either case the arrangement is such that the tattooing device and head can be used to tattoo the unique registration number on both the animal and the registration papers.

Although the invention has been defined above it is to be understood it includes any inventive combination of the features set out above or in the following description.

The invention may be performed in various ways and a specific embodiment will now be described, by way of example, with reference to the accompanying drawings, in which:

Figure 1 shows a cross sectional view through a tattooing head mounted on the shaft of a tattooing device,

Figure 2 shows one form of support for use with a tattooing device,

Figure 3 shows an alternative support,

Figure 4 illustrates schematically a tattooing

device,

Figure 5 shows schematically an actuator for use in that device, and

Figure 6 illustrates one step of the manufacture of the tattooing heads.

A tattooing head 10 comprises a support 11 through which are inserted a plurality of needles 12 arranged to define a pattern or design, such as a number or letter at their tips 13. The needles are retained in the support by a block of epoxy resin 14. The supports 11 are held in a channel-shaped holder 15 and are held therein by inturned lips 16. The holder 15 is open at its ends so that the support or supports 11 can be slid into and out of it.

The head 10 is dimensioned to be slidingly received into a mounting channel 17 where it is retained on shoulders 18,19. The mounting channel is itself located on a shaft 20 which is mounted in a tattooing device 21 (see Figure 4).

A block of absorbent material 22 is attached to the lips 16 by means of double-sided adhesive tape and can be filled with ink by the user; the colour of the ink being selected so as to contrast with the skin colour of the animal. In use the sheath is vibrated longitudinally, by means described below, so that the tips 13 pass through the absorbent material 22

collecting ink on the way and penetrate the skin. They are then immediately withdrawn back into the absorbent material and driven again into the skin with fresh ink. In this way ink can rapidly be introduced into the skin leaving a typical tattoo in the design defined by the tips 13.

It will be understood that by making up each support has an individual letter, number or a bar code element and a range of numbers can be introduced into the holder 15. Figures 2 and 3 show possible constructions for the support and it will be seen that as an alternative a single support can carry several characteristics.

It is envisaged that the support will be made up in a factory in accordance with a computer-generated unique code and a kit having a holder with a coded number mounted therein will be sent to a veterinary together with a set of registration papers, the absorbent material 22, and a light and dark ink. The vet can then locate the holder into the mounting channel of his tattooing device 21 and tattoo both the animal and the registration papers so that there is no possibility of the two bearing different numbers.

The tattooing device 21 is conveniently formed with an anvil clip 23 which can be clipped around the ear of a dog so as to hold it precisely in the correct

position for tattooing. On certain animals it may be desirable to tattoo on the underbelly or inside of the leg and suitable adjustments may be provided for this purpose.

The tattooing device 21 will preferably be rechargeable and one construction of a vibrating actuator is illustrated at 24 in Figure 6. This comprises a solenoid 25 mounted around the shaft 20, a compression spring 26, mounted between the solenoid and a stop 27 held on the shaft 20, and a power supply generator indicated at 28 for the solenoid. This comprises a battery 29, an automatic circuit breaker 30 and an on- and-off switch 31.

The needles 12 may be inserted in the support 11 by hand, but it is preferred that an apparatus be provided for this job particularly as this enhances computer control. Any suitable method may be used. One arrangement could be to provide a block defining a number of sheaths for receiving the needles 12 from which they could be shot out into a matrix of holes 33 in the support 11. The needles could be drawn into this block by a vacuum source and the selection of the character can be made by placing a mask in front of the sheath matrix so that only selected sheaths were not blocked from the vacuum source. Conveniently the series of masks could be mounted on a rotatably circular

support so that any desired character could be called up easily and automatically. Alternatively magnetic means may be provided for drawing the needles 12 into the selected sheath.

When the needles are inserted into the support 11 it is preferred that it is arranged as shown in Figure 6 so that they all engage a surface 34 and in this way project from the support 11 by equal amounts.

CLAIMS

1. A tattooing head comprising a support and a plurality of needles retained in the support such that their tips define a pattern or design.

5 2. A head as claimed in Claim 1 wherein the support is formed as a block or plate having a matrix of holes into which the needles can be inserted to form the particular pattern or design.

10 3. A head as claimed in Claim 1 or claims further comprising a holder for retaining a plurality of supports to make up a composite pattern or design.

15 4. A head as claimed in Claim 3 wherein the holder is in the form of a channel with inturned lips and the supports are dimensioned to be slidingly retained in the holder by the lips with the needles projecting through the mouth of the channel.

20 5. A head as claimed in any one of the preceding claims wherein the pattern or design is a number, a letter, a bar code element, a bar code or other identifying symbol or a combination thereof.

6. A tattooing device comprising a tattoo head having a plurality of needles, a shaft supporting the head and an actuator for longitudinal vibrating the shaft, and hence the head, such that the needles penetrate the skin.

25 7. A device as claimed in Claim 6 further including an ink pad mounted on the head through which the needles pass during vibration by the actuator.

8. A device as claimed in Claim 6 or Claim 7 wherein

the actuator is constituted by a solenoid acting on the shaft and means for pulsing the power supplied to the solenoid.

5 9. A device as claimed in Claim 6 or 7 wherein the actuator includes a motor and a cam mounted for rotation by the motor for engaging the shaft and resilient means for engaging the shaft against the cam.

10 10. A device as claimed in any one of Claims 6 to 10 including a tattoo head as claimed in any one of Claims 1 to 5.

11. A device as claimed in any one of Claims 6 to 10 further including a clip or anvil for holding the device in a pre-set position with respect to a portion of the animal body.

15 12. A device substantially as hereinbefore described with reference to the accompanying drawings.

13. A method of manufacturing a tattooing head comprising forming a support having a matrix of holes and inserting a plurality of needles into respective selected 20 holes in the matrix to define a pattern or design.

14. A method as claimed in Claim 13 comprising means for arranging the needles in the pattern or design.

15 15. A method as claimed in Claim 14 wherein the arranging means comprises a matrix of sheaths into which the needles can be drawn and means for drawing the needles into 25 preselected sheaths.

16. A method as claimed in Claim 15 wherein the drawing means comprises a vacuum source connectable to the

sheaths and a mask apertured to correspond with a particular pattern or design insertable between the vacuum source and the sheaths so that the vacuum source only communicates with selected sheaths.

5 17. A method as claimed in Claim 16 further comprising a plurality of marks corresponding to alphanumeric characters, bar code elements or the like.

18. A method as claimed in any one Claim 15 to 17 wherein the holes in the supports define the sheaths.

10 19. A method as claimed in Claim 15 wherein the drawing means are magnetic means for forming localised magnetic fields around or in sheaths.

15 20. A method as claimed in any one of the preceding Claims 13 to 19 wherein the needles are of stainless steel and the support is of aluminium and wherein relatively cold needles are inserted into a relatively hot support.

20 21. A method as claimed in any one Claims 13 to 19 wherein the support includes a pair of spaced apertured walls and wherein setting material is injected between the walls after the needles have been inserted in the support.

22. A method as claimed in any one of Claims 13 to 21 wherein the support is held above channel during insertion of needles so that the needle length projecting from the support is defined by the depth of the channel.

25 23. A method substantially as hereinbefore described with reference to the accompanying drawings.