



US00D806725S

(12) **United States Design Patent**  
**Ryu**

(10) **Patent No.:** **US D806,725 S**

(45) **Date of Patent:** **\*\* Jan. 2, 2018**

(54) **VEHICLE DASHBOARD WITH ANIMATED GRAPHICAL USER INTERFACE**

(71) Applicant: **LG ELECTRONICS INC., Seoul (KR)**

(72) Inventor: **Seungwon Ryu, Seoul (KR)**

(73) Assignee: **LG ELECTRONICS INC., Seoul (KR)**

(\*\*) Term: **15 Years**

(21) Appl. No.: **35/501,518**

(22) Filed: **Mar. 9, 2016**

(80) **Hague Agreement Data**

Int. Filing Date: **Mar. 9, 2016**  
Int. Reg. No.: **DM/091495**  
Int. Reg. Date: **Mar. 9, 2016**  
Int. Reg. Pub. Date: **Sep. 9, 2016**

(30) **Foreign Application Priority Data**

Sep. 10, 2015 (KR) ..... 30-2015-0046036

(51) **LOC (11) Cl.** ..... **14-04**

(52) **U.S. Cl.**  
USPC ..... **D14/485**

(58) **Field of Classification Search**  
USPC ..... D14/485-488, 490, 494, 489, 491-493, D14/495  
CPC . G06F 3/0482; G06F 3/04842; G06F 3/04817  
See application file for complete search history.

(56) **References Cited**

**U.S. PATENT DOCUMENTS**

D452,693 S \* 1/2002 Mitchell ..... D14/492  
D555,164 S \* 11/2007 Sergio ..... D14/486

D602,037 S \* 10/2009 Nash ..... D14/486  
D752,072 S \* 3/2016 Song ..... D14/486  
D752,618 S \* 3/2016 Lee ..... D14/486  
D760,244 S \* 6/2016 Lv ..... D14/485  
D762,222 S \* 7/2016 Damgaard-Sorensen ... D14/485  
D764,493 S \* 8/2016 Sanderson ..... D14/485  
D772,255 S \* 11/2016 Taylor ..... D14/486  
D776,152 S \* 1/2017 Park ..... D14/488  
D780,772 S \* 3/2017 Kim ..... D14/485  
D784,390 S \* 4/2017 Dye ..... D14/486  
D786,897 S \* 5/2017 Nageli ..... D14/485

\* cited by examiner

*Primary Examiner* — Eric Goodman

*Assistant Examiner* — Nicole Shiflet

(74) *Attorney, Agent, or Firm* — Birch, Stewart, Kolasch & Birch, LLP

(57) **CLAIM**

The ornamental design for a vehicle dashboard with animated graphical user interface, as shown and described.

**DESCRIPTION**

1. Vehicle dashboard with animated graphical user interface  
**1.1** is a front view of the first image in a sequence for a vehicle dashboard with animated graphical user interface showing our new design;  
**1.2** is a front view of the second image thereof;  
**1.3** is a front view of the third image thereof;  
**1.4** is a front view of the fourth image thereof; and  
**1.5** is a front view of the fifth image thereof.  
The appearance of the animated graphical user interface sequentially transitions between the images shown in **1.1-1.5**. The process or period in which on image transitions to another forms no part of the claimed design. The broken lines showing the vehicle dashboard and portions of the graphical user interface form no part of the claimed design.

**1 Claim, 5 Drawing Sheets**

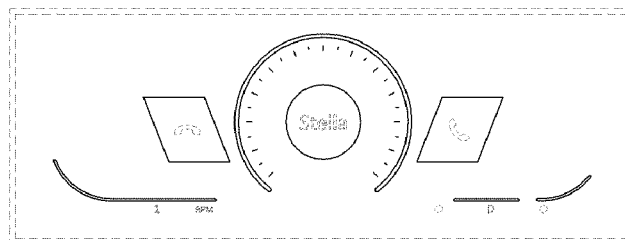
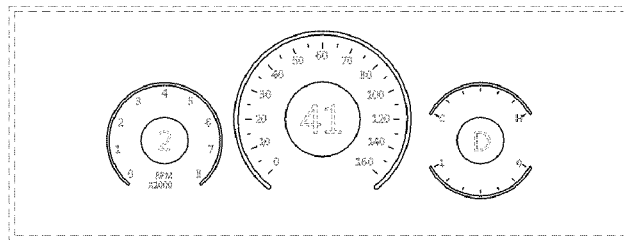

1.1

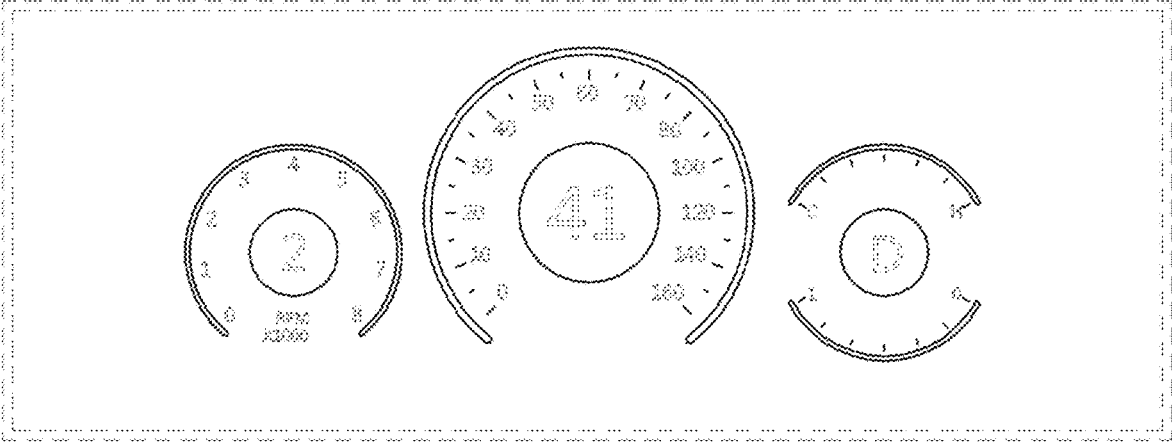

1.2

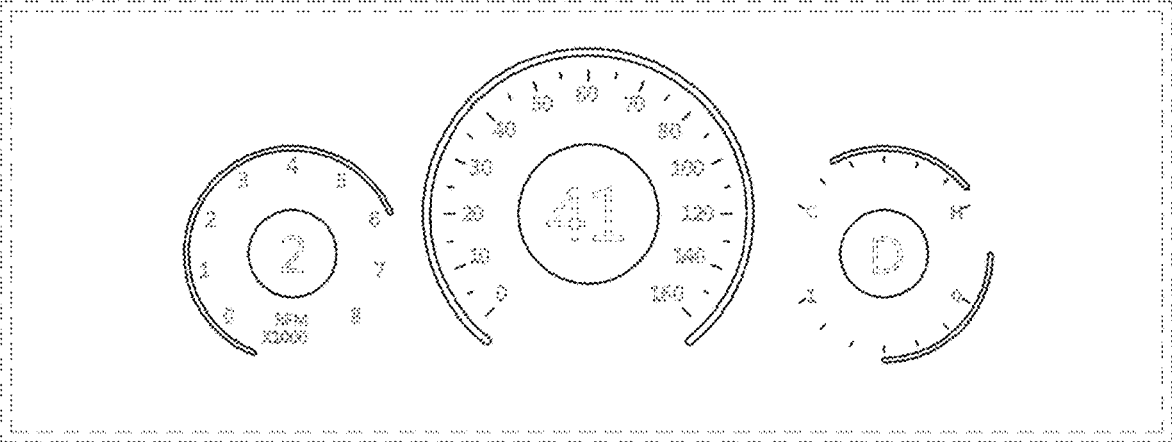

1.3

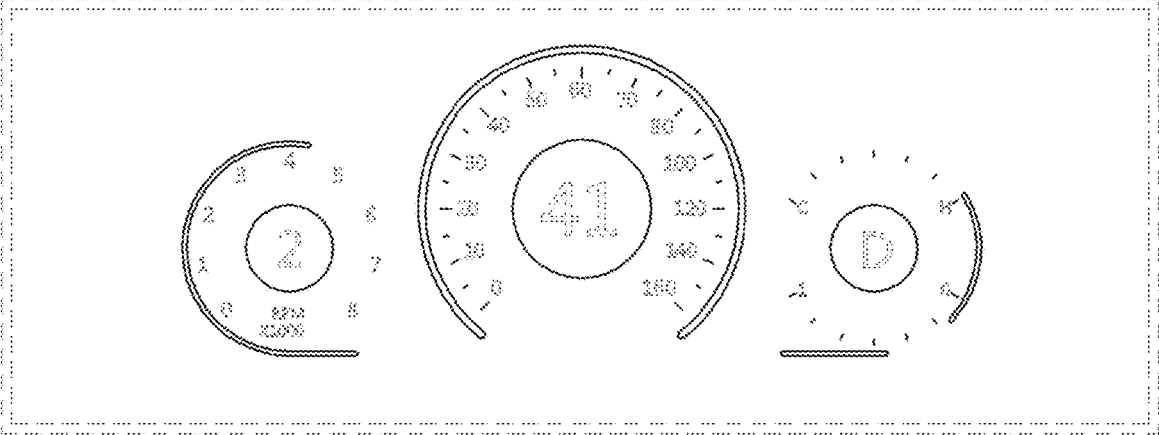

1.4

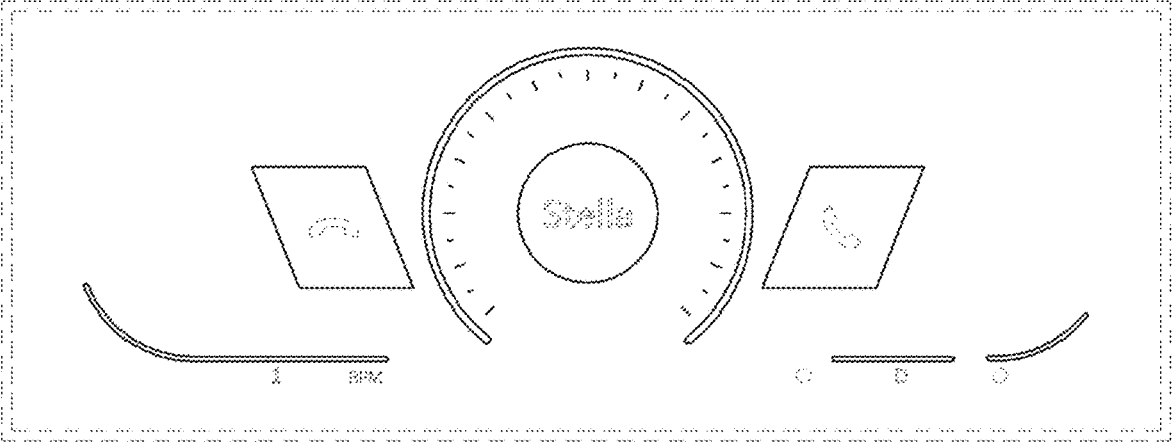

1.5

