



US00D858419S

(12) **United States Design Patent**
Miettinen et al.

(10) **Patent No.:** **US D858,419 S**
(45) **Date of Patent:** **** Sep. 3, 2019**

(54) **PROPULSION UNIT**

(71) Applicant: **ABB OY**, Helsinki (FI)

(72) Inventors: **Pasi Miettinen**, Espoo (FI); **Juho Hannuniemi**, Helsinki (FI); **Veli-Pekka Peljo**, Helsinki (FI); **Tomi Veikonheimo**, Helsinki (FI); **Sami Nivala**, Espoo (FI); **Lauri Lampen**, Helsinki (FI)

(73) Assignee: **ABB Oy**, Helsinki (FI)

(**) Term: **15 Years**

(21) Appl. No.: **35/503,585**

(22) Filed: **Feb. 20, 2017**

(80) **Hague Agreement Data**

Int. Filing Date: **Feb. 20, 2017**

Int. Reg. No.: **DM/094948**

Int. Reg. Date: **Feb. 20, 2017**

Int. Reg. Pub. Date: **Aug. 25, 2017**

(51) **LOC (12) Cl.** **12-06**

(52) **U.S. Cl.**
USPC **D12/308**

(58) **Field of Classification Search**
USPC D12/300, 308, 317
CPC A63B 35/12; B63C 11/46
See application file for complete search history.

(56) **References Cited**

U.S. PATENT DOCUMENTS

D242,615 S * 12/1976 Henning D12/308
4,668,197 A * 5/1987 Proto B63H 5/18
440/3

5,105,753 A * 4/1992 Chih A63B 35/12
114/315
5,303,666 A * 4/1994 DeSantis B63C 11/46
114/315
5,423,278 A * 6/1995 Lashman B63C 11/46
114/315
D471,506 S * 3/2003 Mah D12/308
D487,245 S * 3/2004 Geriene D12/308
D506,176 S * 6/2005 Mah D12/308
D507,776 S * 7/2005 Mah D12/308
D512,678 S * 12/2005 Mah D12/308
D524,225 S * 7/2006 Tsutsumi D12/308
D527,702 S * 9/2006 Mah D12/308
2004/0079272 A1* 4/2004 Mah A63B 35/12
114/315

* cited by examiner

Primary Examiner — Darlington Ly

(74) *Attorney, Agent, or Firm* — J. Bruce Schelkopf; Taft Stettinius & Hollister LLP

(57) **CLAIM**

The ornamental design for a propulsion unit, as shown and described.

DESCRIPTION

1. Propulsion unit
1.1 is a top, front, and left side perspective view of a propulsion unit showing our new design;
1.2 is a front elevation view thereof;
1.3 is a rear elevation view thereof;
1.4 is a right side elevation view thereof;
1.5 is a left side elevation view thereof;
1.6 is a top plan view thereof; and
1.7 is a bottom plan view thereof.
The broken lines in the reproductions illustrate portions of the propulsion device that form no part of the claimed design.

1 Claim, 7 Drawing Sheets

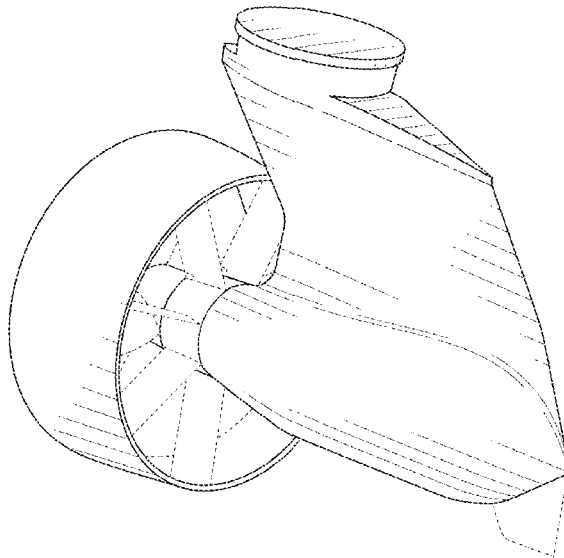

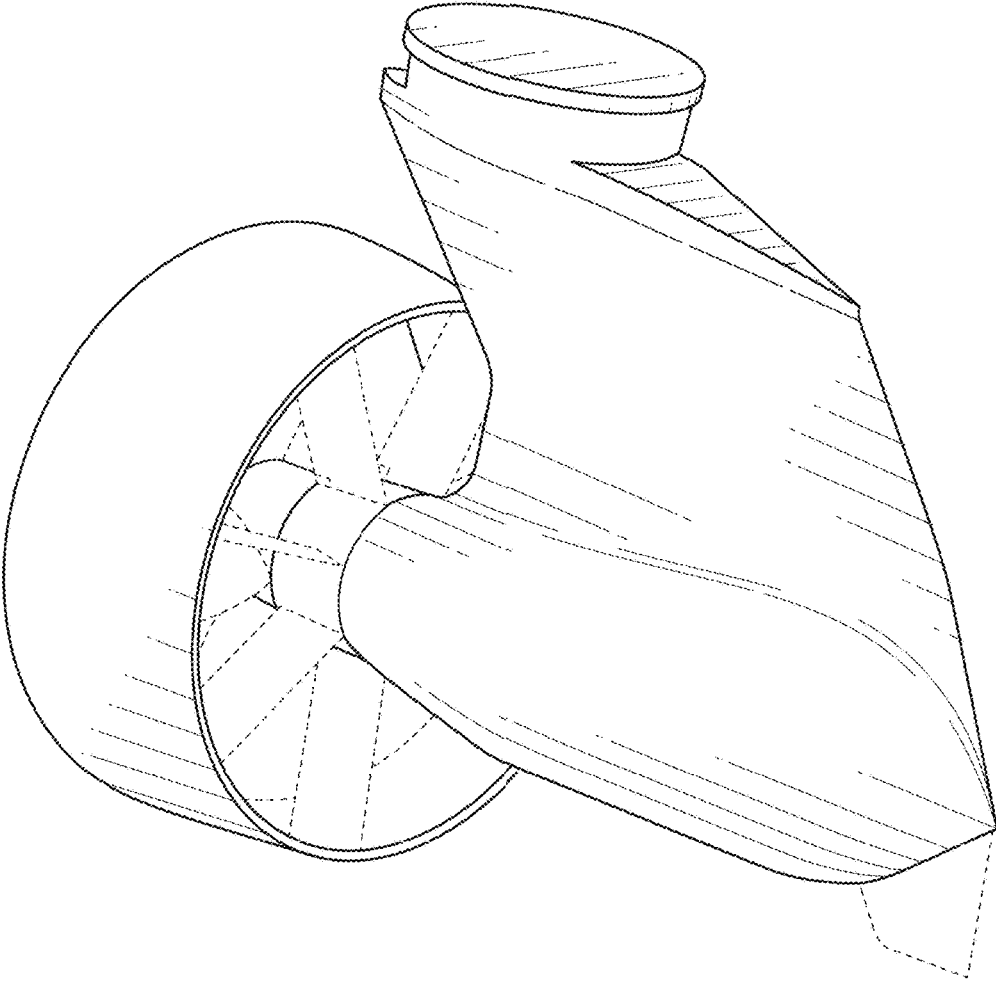

FIG. 1.1

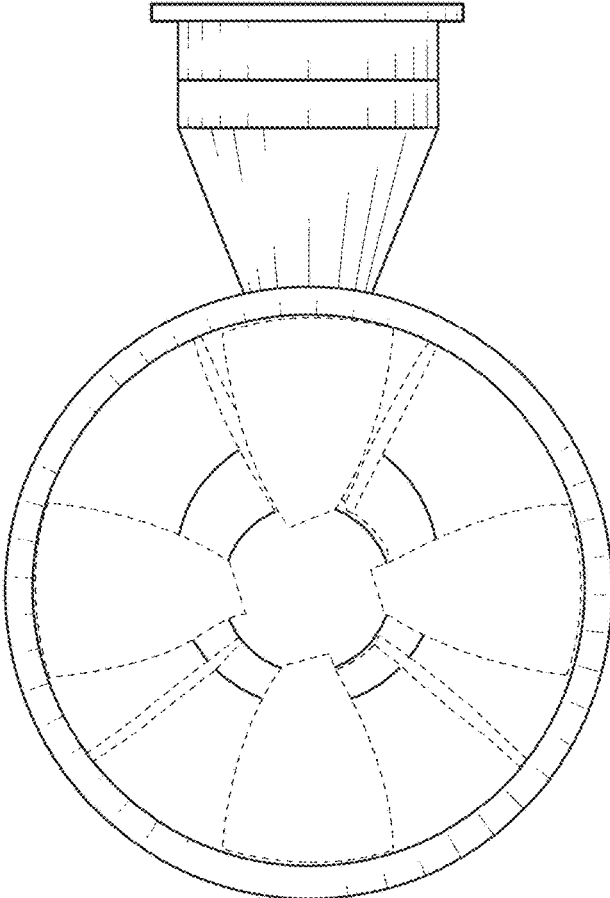

FIG. 1.2

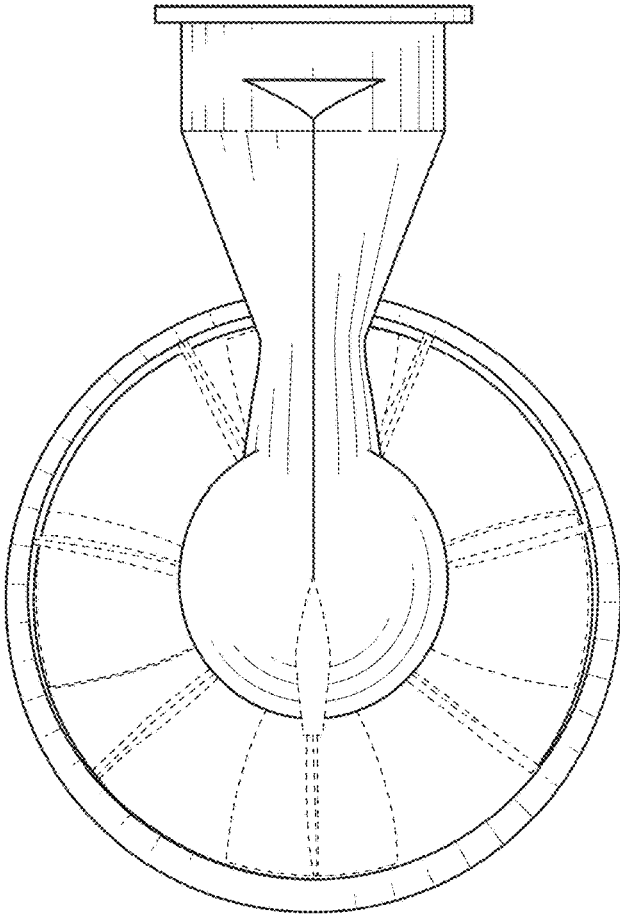

FIG. 1.3

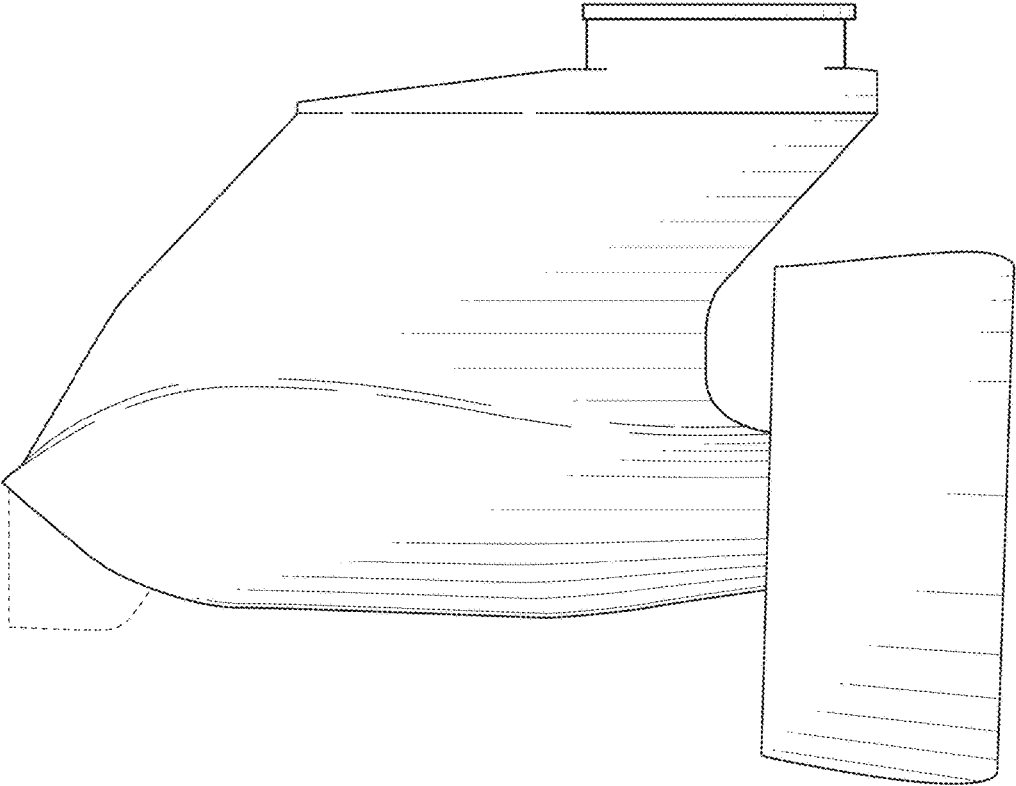

FIG. 1.4

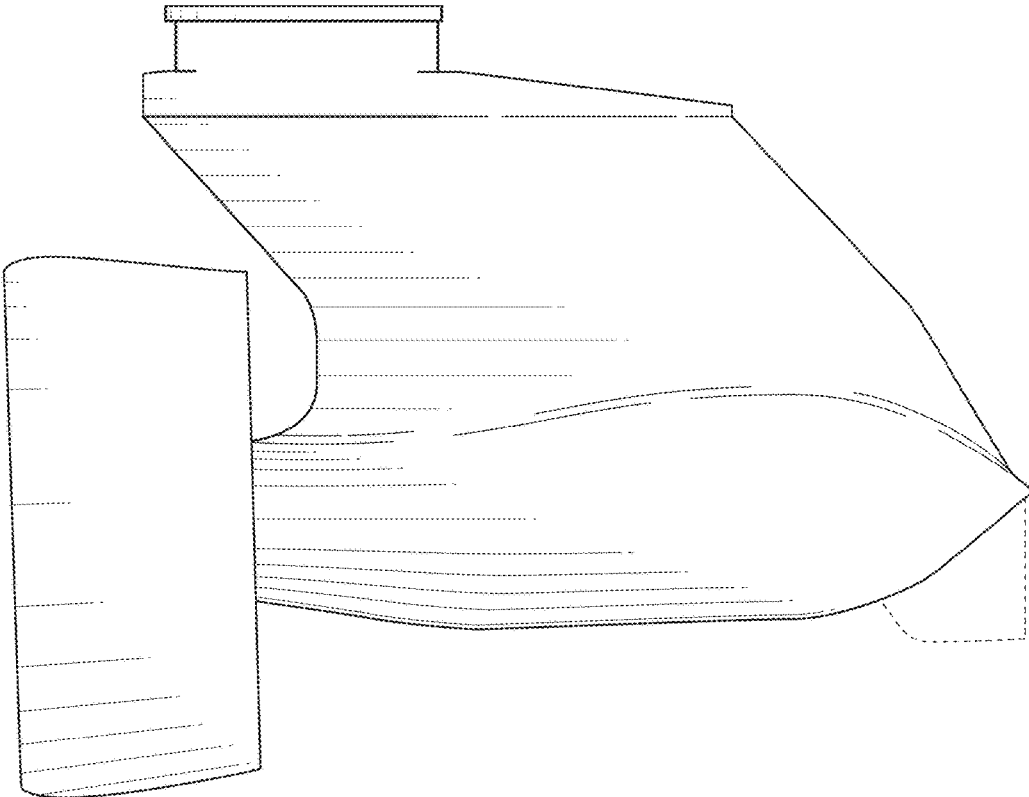

FIG. 1.5

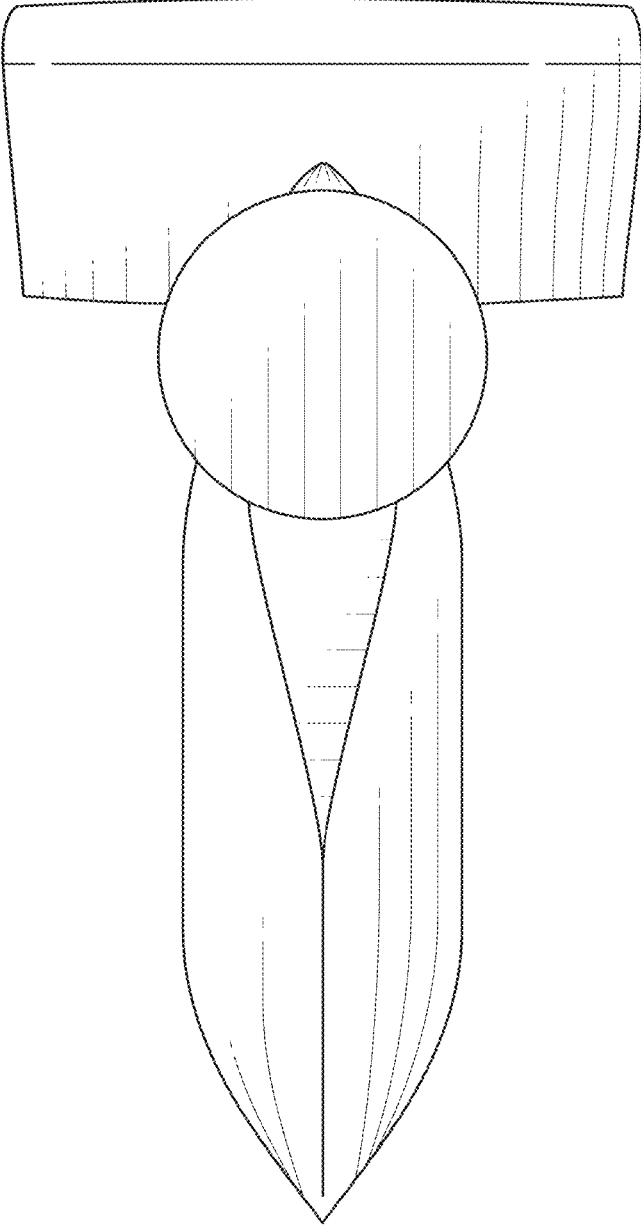

FIG. 1.6

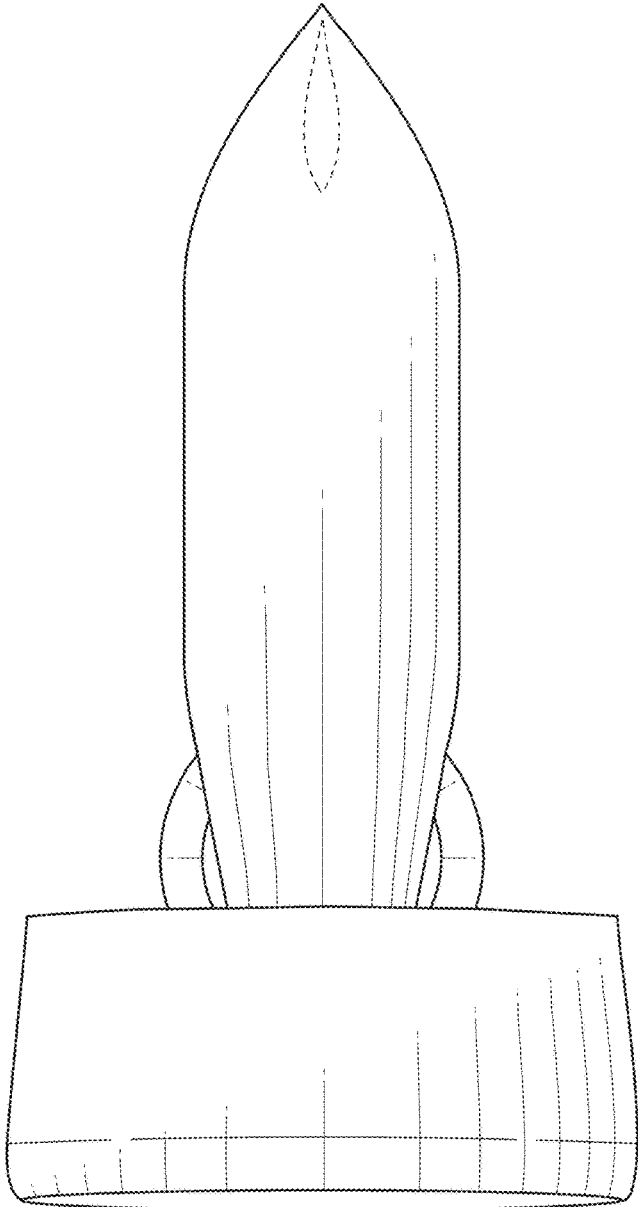

FIG. 1.7