

April 16, 1963

A. J. HOLSTAD

3,085,800

BASKETBALL PRACTICE DEVICE

Filed Sept. 20, 1961

2 Sheets-Sheet 1

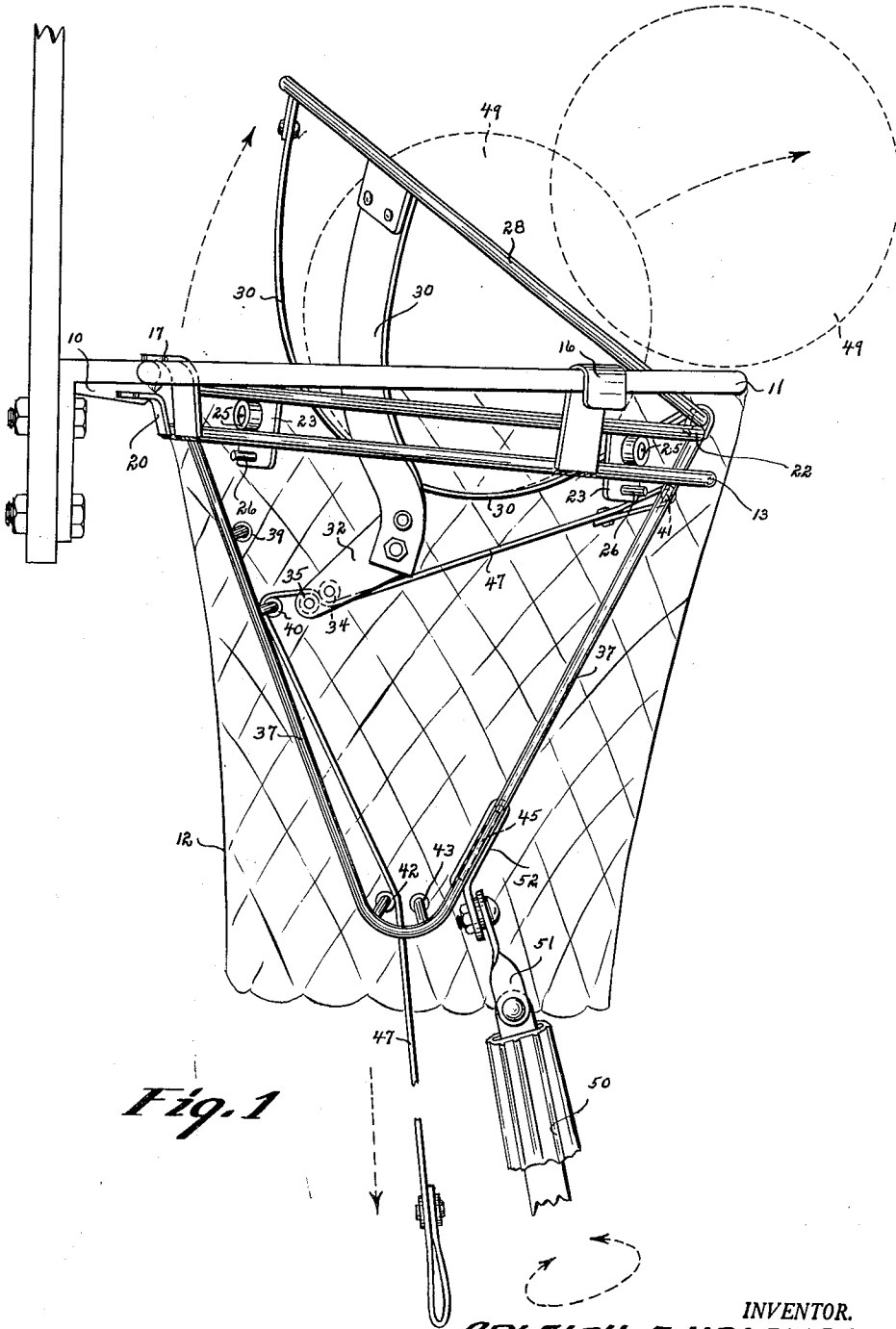

Fig. 1

INVENTOR.
ARLEIGH J. HOLSTAD

BY

Talbert Dick & Farley
ATTORNEYS

WITNESS
NORMAN G. TRAVIS

April 16, 1963

A. J. HOLSTAD

3,085,800

BASKETBALL PRACTICE DEVICE

Filed Sept. 20, 1961

2 Sheets-Sheet 2

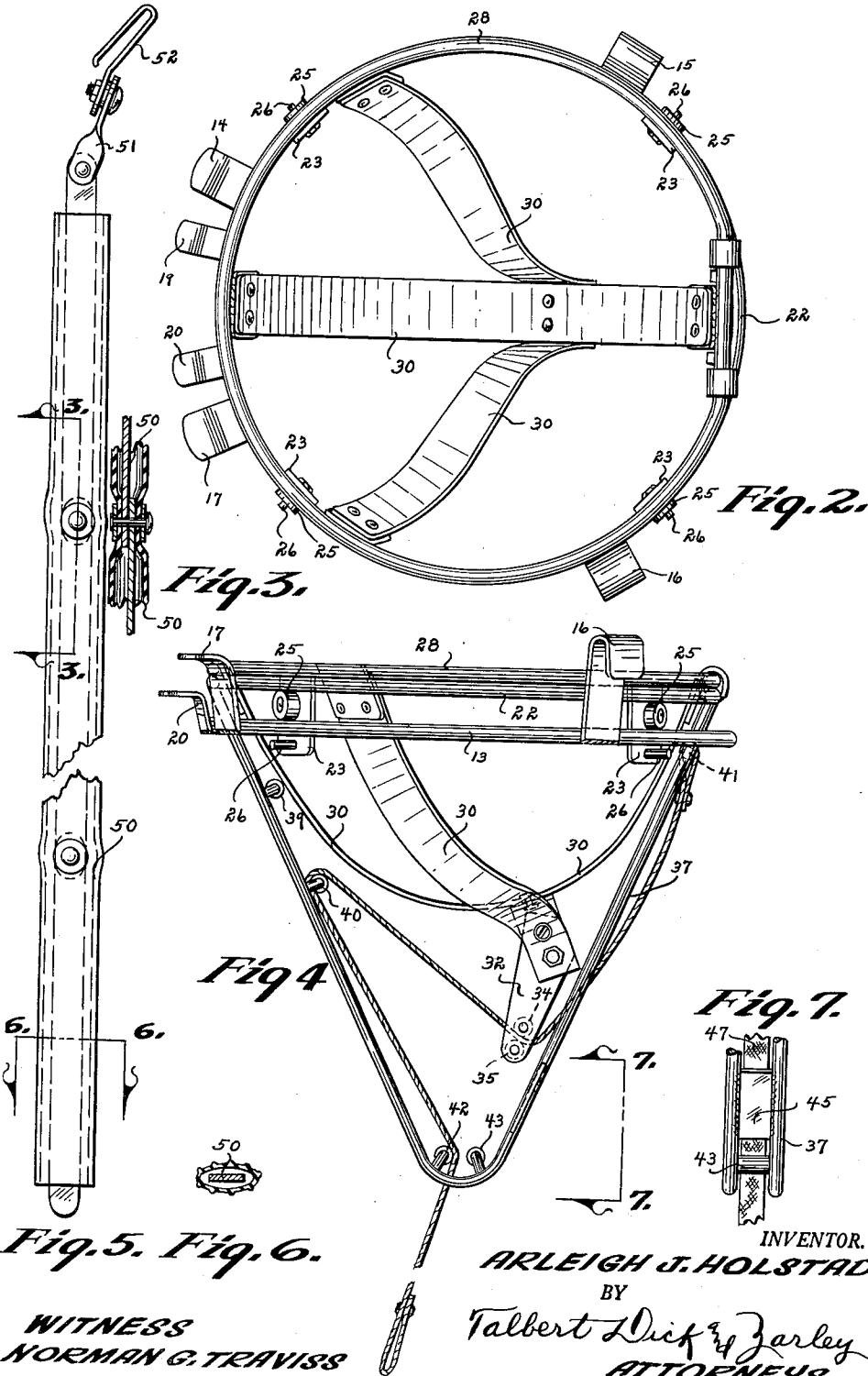

Fig. 3.

Fig. 2.

Fig. 4.

Fig. 7.

Fig. 5. Fig. 6.

WITNESS
NORMAN G. TRAVIS

INVENTOR.
ARLEIGH J. HOLSTAD
BY
Talbert Dief & Zarley
ATTORNEYS

1

3,085,800

BASKETBALL PRACTICE DEVICE

Arleigh J. Holstad, 102 4th St. N., Northwood, Iowa

Filed Sept. 20, 1961, Ser. No. 139,494

11 Claims. (Cl. 273-1.5)

This invention relates to a device for aiding the practice of the game of basketball, and more particularly to a device that will first retain the ball in the basket and then exit the ball from the basket in a direction radial to the basket, and is a continuation in part of my pending application on a Basketball Practice Device filed September 2, 1959, Serial Number 837,705.

Perhaps two of the most important phases in the practicing of a basketball player are those of placing the basketball in the basket, and retrieving the basketball on rebound. The present standard basketball basket is not particularly adaptable to either the one practicing the game or to the coach. One reason for this is that a ball thrown into the basket will pass directly downwardly through the open bottom net of the basket. Obviously, this does not develop skill in rebounding for either the basket shooter or other individuals in the vicinity of the basket. Furthermore, if the shooter is to practice the art of shooting for foul points, he cannot remain in one position during this practice but must retrieve the ball each time he shoots from a point directly below the basket.

Therefore, one of the principal objects of my invention is to provide a device attachable to a standard basketball basket that will receive and retain the ball passed into the basket and will then at any desired time eject the ball in any selected direction laterally from the basket.

A further object of this invention is to provide a basketball training aid that may be easily and quickly secured onto a standard basketball basket.

A still further object of this invention is to provide a basketball casting device that may be operated by the player or by the coach.

A still further object of this invention is to provide a basketball casting device in association with a basketball basket that may be actuated at a distance from that of the vicinity of the basket.

A still further object of this invention is to provide a device for casting basketballs from a basketball basket that may be adjustably controllable to cause the ball to be cast in various radial directions from the basket.

Still further objects of my invention are to provide a basketball practice device that is economical in manufacture and durable in use.

These and other objects will be apparent to those skilled in the art.

My invention consists in the construction, arrangements, and combination, of the various parts of the device, whereby the objects contemplated are attained as hereinafter more fully set forth, specifically pointed out in my claims, and illustrated in the accompanying drawings, in which:

FIG. 1 is a side view of my invention installed on a basketball basket and ready for use.

FIG. 2 is a top plan view of my basketball practice device.

FIG. 3 is a cross sectional view taken on line 3-3 of FIG. 5.

FIG. 4 is a side plan view of my device and more fully illustrates its construction.

FIG. 5 is a side plan view of the rotating and positioning means of my basketball practice device.

FIG. 6 is a cross sectional view taken on line 6-6 of FIG. 5 and,

FIG. 7 is a sectional view taken on line 7-7 of FIG. 4. In these drawings I have used the numeral 10 to design-

2

nate a supporting member holding an ordinary standard basketball basket, as shown in FIG. 1. This basket rim is designated by the numeral 11 and has the usual downwardly extending open end net 12. It is to such a device that I secure my training aid and which I will now describe in detail.

The numeral 13 generally designates the base ring. Secured in spaced relationship on the base ring are four hook or like members 14, 15, 16 and 17. These hook members extend upwardly and outwardly and are adapted to engage the basketball basket rim 11. The two hook members 14 and 17 are closer together than they are to the other hook members and are adapted to extend at each side of the fixture that supports the rim 11. The numerals 19 and 20 designate two spaced apart tab hook members disposed on the base ring 13 between the hook members 14 and 17. The tab hooks 19 and 20 extend radially first upwardly and outwardly and then outwardly from the base ring 13 and are adapted to extend immediately under the basket rim 11 in order to keep the device from being jounced out of position during active use and also extend respectively on each side of the fixture that supports the basket rim 11 in order to keep the base ring 13 from accidentally rotating during active use, best shown in FIG. 1. If desired, the hook members 15 and 16 may extend higher than the hook members 14 and 17 in order to give the base ring 13 a slight forward tilt in relation to the basket rim 11. Also, the base ring 13 is of a smaller diameter than the rim 11 and adapted to be suspended by means of the supporting hooks 14, 15, 16 and 17 interior of and below the rim 11.

The numeral 22 designates a rotatable ring. Extending downwardly from the ring 22 are a plurality of spaced apart bars 23. Each of these bars 23 extend downwardly immediately interior of the base ring 13 and below the bottom plane of the base ring 13. The numeral 25 designates a wheel, or like, rotatably mounted on the outer side of each of the bars 23 and above the top plane of the base ring 13. The numeral 26 designates an outwardly extending lug, or like, on the lower end portion of each of the bars 23. These lugs extend radially outwardly below the bottom plane of the base ring 13 and act as limiting stops for preventing unlimited upward movement of the rotatable ring 22 relative to the base ring 13. By this arrangement of elements the rotatable ring 22 will be rotatably mounted onto and directly above the base 13.

The numeral 28 designates my hinged ring vertically hingedly secured by any suitable means to the rotatable ring 22, as shown in FIG. 1. The rings 13, 22 and 28 are all of substantially the same diameter. By this arrangement of elements, the hinged ring 28 may be swung upwardly and outwardly, but is limited in its inward and downward swinging movement by contact with the rotatable ring 22.

The numeral 30 designates a plurality of straps having their upper ends secured to the hinged ring 28. These straps extend downwardly and inwardly to form an open grid basketball receiving pocket, as shown in FIGS. 2 and 4.

The numeral 32 designates an open arm frame depending from the lower areas of the straps 30 as shown in FIG. 4. At the outer end of the arm frame are two spaced apart belt guide rollers, or like, 34 and 35, respectively. The numeral 37 designates a depending V-shaped open frame having its two upper ends secured at diametrically opposite positions on the rotatable ring 22. The numerals 39 and 40 designate two spaced apart belt guide rollers, or like, rotatably mounted on the upper portion of one side of the V-shaped frame 37. The numeral 41 designates a belt anchoring bar on the upper end portion of the opposite side of the V-shaped frame

37. The numerals 42 and 43 designate two spaced apart belt guide rollers rotatably secured at the lower end of the V-shaped frame 37. The numeral 45 designates a rectangular plate secured to the lower end portion of the V-shaped frame 37. The numeral 47 designates a flexible elongated belt strap having its upper end secured to the bar 41 and which is positioned in the vicinity of the hinge point of the hinged ring 28. This belt strap extends from the bar 41 between the two belt guide rollers 34 and 35, thence between the two belt guide rollers 39 and 40, and thence between the two belt guide rollers 42 and 43, as shown in FIG. 4.

Any suitable elongated tool may be used for placing the device into and onto the basket rim 11 as shown in FIG. 1. When the device is so placed the base ring 13 will be rigidly held against rotation and also the device will not accidentally move from the basket rim 11 because of the finger projections 19 and 20 extending under the basket rim 11. Obviously when the device is installed for use, the basketball 49 is thrown into the top ring of the basketball basket, and it will be prevented from moving completely downwardly and out through the net 12. Instead the basketball will be retained onto and in the straps 30 that makes up the ball receiving frame. This retention of the basketball within the net area is highly desirable for training purposes and especially for the development of proper coordination and timing. The time period the basketball will be retained within my device will depend upon the time the hinged ring is in a normal horizontal position within the basket. If the hinged ring is swung upwardly and outwardly as shown in FIG. 1, the basketball will be cast also upwardly and outwardly. Various means such as a rope shown in FIG. 4 may be used for moving my hinged ring upwardly and outwardly. I recommend the use of the strap belt shown in the drawings. To eject the ball it is merely necessary to pull on the lower end of the strap belt. The free end of the strap belt may extend not only downwardly but horizontally so that it can be actuated by the coach or by others or even by the one shooting the ball from the foul line. The direction the basketball will be cast will depend upon the position of the hinged area of the hinged ring i.e., the ball will always be cast over the hinged area of the ring 28. Therefore the selectivity of position of the rotatable ring 22 is most important. In many instances it will be desired to cast the ball directly back to the foul line area but in other situations and conditions it may be desirable to cast the ball at different angles to the left or to the right. Obviously this may be accomplished merely by the rotation of the rotatable ring 22. Inasmuch as the V-shaped frame 37 is attached to the rotatable ring, it is merely necessary to rotate this V-shaped frame to accomplish the desired positioning of the rotatable ring 22 and hinged ring 28. To facilitate rotation of this rotatable portion of my device I have provided an elongated handle generally designated by the numeral 50. This elongated handle should have its length of hinged together parts such as shown in FIG. 3 but not rotatable. By being so hinged the handle may be built horizontally in its lower end and therefore the operator can stand at any position remote from that position directly under the basket and if the upper end of the tool is secured to the V-shaped frame, a turning of the tool will also affect the rotation of the V-shaped frame and its associated members. Therefore at the upper end of the member 50 I provide a link 51 hinged thereto, and transversely hinged to the upper end of the link 51, a hook portion 52 as shown in FIG. 5. When it is desired to rotate the rotatable portion of the device, this hook portion 52 is detachably hooked over, onto, and around the plate 45 as shown in FIG. 1. This tool 50 with the strap 47 provides complete control of the device at all times. The hinged portion may be so designed so that the hinged ring will have limited throw and after it has cast out the basketball it will, by gravity, move back to its

position found in FIG. 4 for receiving the next basketball. The arrangement of the strap is such that it will not throw the hinged ring completely forwardly regardless of how hard the strap is pulled and this action is shown in FIG. 1.

Some changes may be made in the construction and arrangement of my basketball practice device without departing from the real spirit and purpose of my invention, and it is my intention to cover by my claims, any modified forms of structures or use of mechanical equivalents which may be reasonably included within their scope.

I claim:

1. In a basketball playing aid, a basic ring frame, hook portions on the basic ring adapted to extend over the ring of a basketball basket, a hinge ring, a means operatively hingedly securing said hinge ring to said basic ring, a basketball receiving frame secured within and to said hinge ring and extending downwardly from said hinge ring, and a flexible member having one end operatively secured to said basic ring frame and its length engaging the bottom of said basketball receiving frame for moving said hinge ring to eject a received basketball.

2. In a basketball playing aid, a basic ring frame, hook portions on the basic ring adapted to extend over the ring of a basketball basket, a hinge ring, a means operatively hingedly securing said hinge ring to said basic ring, a basketball receiving frame secured within and to said hinge ring and extending downwardly from said hinge ring, and a flexible member having one end operatively secured to said basic ring frame and its length engaging the bottom of said basketball receiving frame for moving said hinge ring to eject a received basketball, said basic ring having a diameter less than that of the diameter of the upper portion of a basketball basket.

3. In a basketball playing aid, a basic ring frame, portions on the basic ring adapted to extend over the ring of a basketball basket, a hinge ring, a means operatively hingedly securing said hinge ring to said basic ring, a basketball receiving frame secured within and to said hinge ring and extending downwardly from said hinge ring, and a flexible member having one end operatively secured to said basic ring frame and its length engaging the bottom of said basketball receiving frame for moving said hinge ring to eject a received basketball.

4. In a basketball playing aid, a basic ring frame, hook portions on the basic ring adapted to extend over the ring of a basketball basket, a hinge ring, a means operatively hingedly securing said hinge ring to said basic ring, a basketball receiving frame secured within and to said hinge ring and extending downwardly from said hinge ring, two spaced apart guide members on the underside of said basketball receiving frame, and a flexible elongated member having one end operatively secured to said basic ring and its length extending between said two guide members for moving said hinge ring to eject a received basketball.

5. In a basketball playing aid, a basic ring frame, hook portions on the basic ring adapted to extend over the ring of a basketball basket, a hinge ring, a means operatively hingedly securing said hinge ring to said basic ring, a basketball receiving frame secured within and to said hinge ring and extending downwardly from said hinge ring, two spaced apart guide members on the underside of said basketball receiving frame, one of which at least is a rotatably mounted roller, and a flexible elongated member having one end operatively secured to said basic ring and its length extending between said two guide members for moving said hinge ring to eject a received basketball.

6. In a basketball playing aid, a basic ring frame, hook portions on the basic ring adapted to extend over the ring of a basketball basket, a hinge ring, a means operatively hingedly and rotatably securing said hinge ring to said basic ring, a basketball receiving frame secured within and to said hinge ring and extending downwardly from said hinge ring, and a flexible member having one end

5

operatively secured to said basic ring frame and its length engaging the bottom of said basketball receiving frame for moving said hinge ring to eject a received basketball.

7. In a basketball playing aid, a basic ring frame, means for securing said basic ring frame to a basketball basket, a rotatable ring frame horizontally rotatably secured to said basic ring frame, a frame depending downwardly from said rotatably mounted frame, a hinge ring operatively hingedly secured to said rotatably mounted ring frame, a basketball receiving frame secured within and to said hinge ring and extending downwardly from said hinge ring and an elongated flexible member having one end operatively secured to said rotatably mounted ring and with its length operatively slidably engaging said basketball receiving frame whereby when it is manually pulled said basketball receiving frame and hinge ring will be swung upwardly and outwardly to eject a received basketball.

8. In a basketball playing aid, a basic ring frame, means for securing said basic ring frame to a basketball basket, a rotatable ring frame horizontally rotatably secured to said basic ring frame, a V-shaped frame depending downwardly from said rotatably mounted frame, a hinge ring operatively hingedly secured to said rotatably mounted ring frame, a basketball receiving frame secured within and to said hinge ring and extending downwardly from said hinge ring and an elongated flexible member having one end operatively secured to said rotatably mounted ring and with its length operatively slidably engaging said basketball receiving frame whereby when it is manually pulled said basketball receiving frame and hinge ring will be swung upwardly and outwardly to eject a received basketball.

9. In a basketball playing aid, a basic ring frame, means for securing said basic ring frame to a basketball basket, a rotatable ring frame horizontally rotatably secured to said basic ring frame, a frame depending downwardly from said rotatably mounted frame, a hinge ring operatively hingedly secured to said rotatably mounted ring frame, a basketball receiving frame secured within and to said hinge ring and extending downwardly from said hinge ring, an elongated flexible member having one end operatively secured to said rotatably mounted ring and with its length operatively slidably engaging said basketball receiving frame whereby when it is manually pulled said basketball receiving frame and hinge ring will be swung upwardly and outwardly to eject a received basketball, a plate member on said frame that is secured to

6

said rotatably mounted ring frame, a flexible non-rotatable elongated tool and a hook on said elongated tool detachably engaging said plate member; said hook being hingedly secured to one end of said elongated flexible tool.

10. In a basketball playing aid, a basic ring frame, means for securing said basic ring frame to a basketball basket, a rotatable ring frame horizontally rotatably secured to said basic ring frame, a frame depending downwardly from said rotatably mounted frame, a hinge ring operatively hingedly secured to said rotatably mounted ring frame, a basketball receiving frame secured within and to said hinge ring and extending downwardly from said hinge ring, an arm extending from the bottom of said basketball receiving frame, two spaced apart strap guide members on said arm, a flexible strap having one end secured to said depending frame and its length extending between said two strap guide members, and a roller on said depending frame engaging the underside of said flexible strap whereby when said flexible strap is pulled downwardly it will elevate said basketball receiving frame.

11. In a basketball playing aid, a basic ring frame, means for securing said basic ring frame to a basketball basket, a rotatable ring frame horizontally rotatably secured to said basic ring frame, a frame depending downwardly from said rotatably mounted frame, a hinge ring operatively hingedly secured to said rotatably mounted ring frame, a basketball receiving frame secured within and to said hinge ring and extending downwardly from said hinge ring, two spaced apart cable guide members operatively secured to the bottom of said basketball receiving frame, two spaced apart cable guide members at the lower end of said depending frame, a cable guide member on said depending frame and above the lower portion thereof, and an elongated flexible cable having one end secured to said depending frame with its length extending between the two cable guide members on the bottom of the basketball receiving frame, thence normally upwardly and extending over the last mentioned cable guide member on said depending frame and thence downwardly between the two cable guide members on the lower end of the said depending frame.

References Cited in the file of this patent

UNITED STATES PATENTS

2,130,820	Trumbull	Sept. 20, 1938
2,808,264	Scaf	Oct. 1, 1957