

[54] **SASH LOCK**  
 [75] Inventor: **Wayne C. Bates**, Owatonna, Minn.  
 [73] Assignee: **Truth Incorporated**, Owatonna, Minn.  
 [22] Filed: **Aug. 10, 1972**  
 [21] Appl. No.: **279,371**

220,046 9/1879 Wilson..... 292/241  
 3,645,573 2/1972 Strang..... 292/241

*Primary Examiner*—Richard E. Moore  
*Attorney, Agent, or Firm*—Hofgren, Wegner, Allen, Stelman & McCord

[52] **U.S. Cl.**..... 292/241, 292/DIG. 38  
 [51] **Int. Cl.**..... E05c 3/04  
 [58] **Field of Search**..... 292/190, 101, 107, 241, 292/242, DIG. 38, 202

[57] **ABSTRACT**

A sash lock for double hung windows with the locking lever thereof provided with a smooth top to avoid collection of dirt and other foreign material and having design strength even if made of plastic to function with a keeper member to draw the window sash together in a vertical direction and having a second, unexposed, cam surface coacting with a lug on a keeper member to draw the meeting rails of the sash tightly together in a horizontal direction.

[56] **References Cited**  
**UNITED STATES PATENTS**

2,258,617 10/1941 Knauff..... 292/241  
 2,422,723 6/1947 Fisher..... 292/241 X

**8 Claims, 5 Drawing Figures**

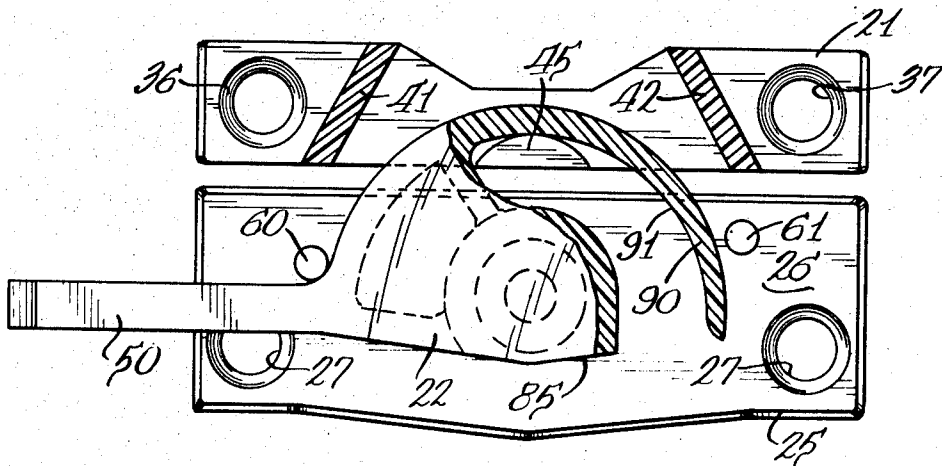

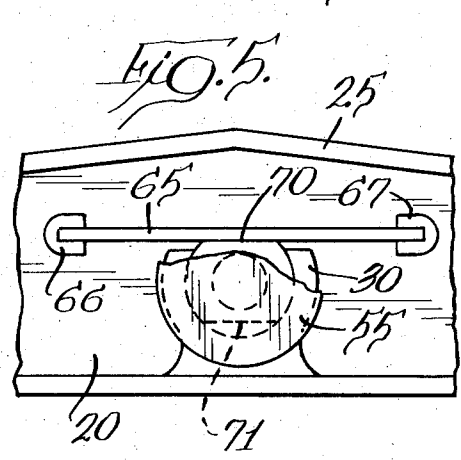
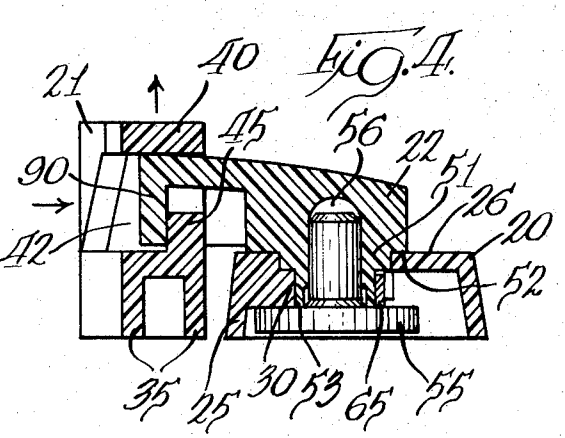
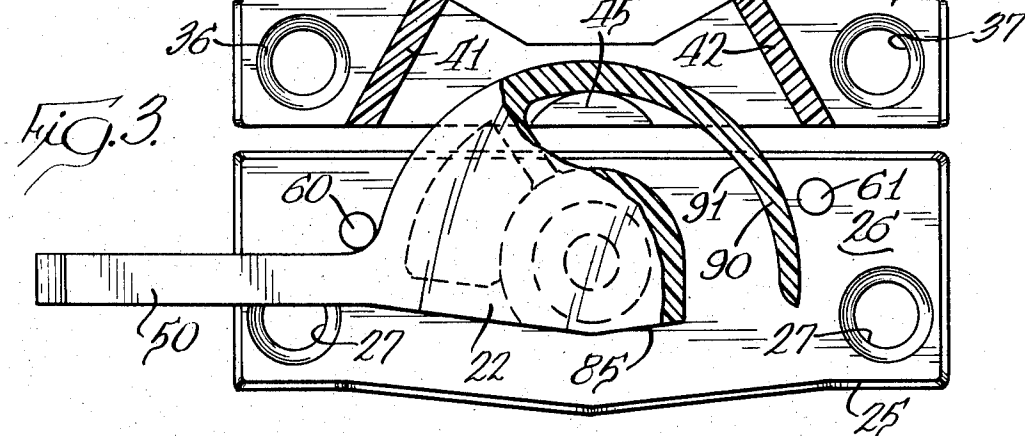
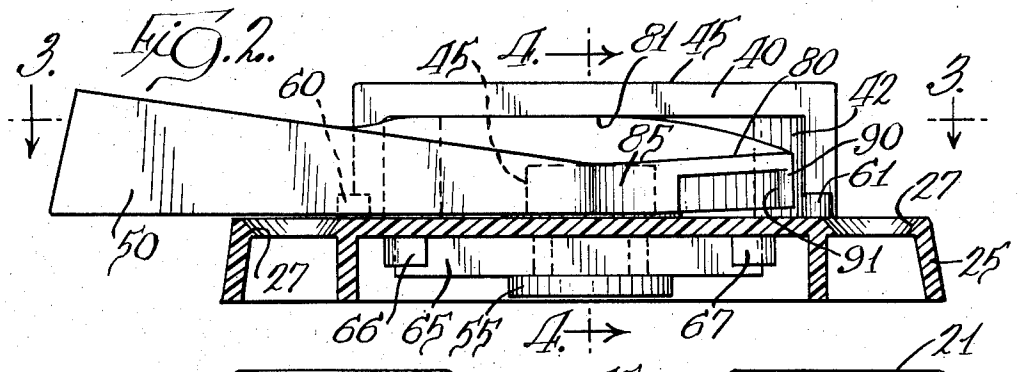
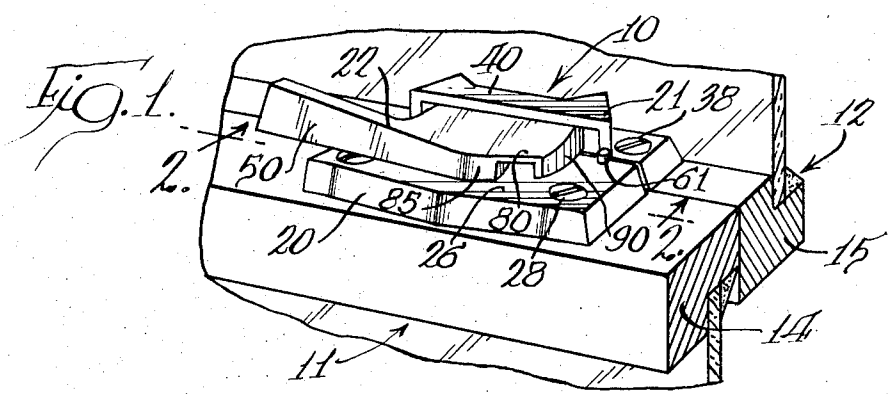

## SASH LOCK

## BACKGROUND OF THE INVENTION

This invention pertains to a sash lock for a double hung window wherein the parts may be economically fabricated from metal or molded plastic material and still have the strength to perform the normal locking functions of such a sash lock and with the sash lock having a neat, attractive appearance without any exposed grooves for collecting of dirt or other foreign matter.

Many forms of sash lock are known in the art, with prior sash locks of interest and known to applicant being shown in U.S. Pat. Nos. 220,046; 952,277; 2,422,723; and 3,306,644. An attempt to have a sash lock of plastic material is shown in U.S. Pat. No. 3,645,573.

Most sash locks for double hung windows in homes have a keeper member mounted on the meeting rail of the upper sash and a locking lever pivotally mounted on the top of the meeting rail of the lower sash and with the locking lever being rotatable through part of a revolution to engage the keeper member and lock the sash together. Generally, the locking lever has an upwardly extending peripheral flange which coacts with the keeper member to draw the meeting rails together both in horizontal and vertical directions. Such structures have had a shape wherein dust and dirt are collected, with the result that the sash lock frequently needs cleaning, which is difficult to do. The sash lock, as disclosed herein, has a locking lever, with a smooth top surface to avoid any surfaces or shapes which are difficult to clean. The sash lock, with the smooth top surface, has sufficient strength to permit use of plastics whereby a peripheral section thereof may coact with the keeper member to draw the meeting rails of the sash together in a vertical direction and with a hidden, depending peripheral flange coacting with an upstanding lug on the keeper member to draw the meeting rails together in a horizontal direction.

## SUMMARY

The invention disclosed herein provides a sash lock which may be economically made from metal or molded plastic parts with structural strength to withstand the forces encountered in use and with no exposed dirt-collecting shape which is difficult to clean.

The invention disclosed herein embodies a base member which rotatably mounts a locking lever, with the locking lever having a smooth top surface with an arcuate peripheral section thereof being upwardly inclined from a leading edge to coact with a bridge section of a keeper member to cam the parts in a direction to move the window sash to tightly closed relation in a vertical direction and with a second cam surface on the locking lever in the form of a hidden, depending peripheral flange for coaction with an upstanding lug on the keeper member to draw the meeting rails of the sash together in a horizontal direction as the locking lever moves to locked position.

An object of this invention is to provide a new and improved sash lock which may be made either of metal or of molded plastic.

Another object of the invention is to provide a sash lock for double hung windows with a locking lever pivotally mounted on the top of the meeting rail of the

lower sash for coaction with a keeper member mounted on the meeting rail of the upper sash and with a pair of cam surfaces on the locking lever, with one of the cam surfaces being formed by a peripheral section of the smooth top of the locking lever to coact with structure on the keeper member to lock the sash together in tightly fitted relation.

Other objects of the invention are to provide a sash lock as defined in the preceding paragraphs wherein the sash lock components may be formed of either metal or molded plastic and with a pivot pin for the locking lever having a pair of flats coacting with a spring member mounted in the base member which mounts the locking lever to engage one or the other of said flats and hold the locking lever either in unlocked or locked position, and a pair of surfaces extending upwardly from the base member in spaced-apart relation to limit the movement of the locking lever in both locked and unlocked positions.

## BRIEF DESCRIPTION OF THE DRAWING

FIG. 1 is a perspective view of the sash lock associated with a double hung window and shown in locked position;

FIG. 2 is a vertical section, on an enlarged scale, taken generally along the line 2—2 in FIG. 1;

FIG. 3 is a plan section taken generally along the line 3—3 in FIG. 2 and with parts of the locking lever broken away;

FIG. 4 is a vertical section taken generally along the line 4—4 in FIG. 2; and

FIG. 5 is a fragmentary, bottom plan view of the base member which mounts the locking lever with a part broken away.

## DESCRIPTION OF THE PREFERRED EMBODIMENT

The sash lock embodying the invention is shown generally in FIG. 1, wherein the sash lock, indicated generally at 10, is associated with a double hung window sash having a lower sash, indicated generally at 11, and an upper sash, indicated generally at 12. Each of the sashes has a meeting rail 14 and 15, respectively, which, when the window is fully closed, are at the same vertical level and are drawn together in a horizontal direction to effectively seal the gap. Commonly, a weatherstrip would be located between the meeting rails 14 and 15.

The sash lock 10 has three primary components, namely, a base member 20, a keeper member 21 and a locking lever 22. These parts may be of metal or of molded plastic material to provide a low-cost sash lock structure and the structure is designed to withstand the forces encountered in locking a window, even though made of molded plastic.

The base member 20 is generally rectangular and has a raised, peripheral wall 25 around the four sides thereof to provide an elevated planar top 26 with a pair of openings 27 therethrough to receive screws 28 for mounting thereof to the meeting rail 14 of the lower sash 11.

A generally, semicircular depending flange 30 extends downwardly from the underside of the top panel 26 of the base member 20 to define a rotational mounting for a pivot pin of the locking lever, to be described.

The keeper member 21 has a generally rectangular base with a depending peripheral wall 35 to rest upon the top of the meeting rail 15 for the upper sash 12 and with a raised planar part having openings 36 and 37 through which screws 38 may pass to lock the keeper member to the meeting rail 15. The keeper member 21 has a raised bridge section 40 connected to the base thereof by a pair of vertically extending spaced-apart walls 41 and 42 which angle toward each other, from front to rear of the keeper member 21. The bridge section 40 overlies an upstanding lug 45 formed on the keeper member 21. The lug 45 has a curved rear surface, as shown in FIG. 3 and a height substantially equal to one-half the distance between the bridge section 40 and the base of the keeper member 21.

The locking lever 22 has an operating handle 50 extending from the body thereof, with the body having a central, solid section 51 defining a downwardly facing annular surface 52 which rests upon the planar top 26 of the base member. A projecting pin part 53 of the body fits within the semicircular flange 30 of the base member to rotatably locate the locking lever. A headed plug 55 fits within an interior opening 56 within the pin part 53 of the locking lever to hold the locking lever in assembled relation with the base member 20. The headed plug can be suitably affixed to the underside of the locking lever as by sonic welding when the parts are of plastic.

The locking lever 22 can be rotated through part of a revolution between the locked position, shown in FIGS. 1 to 3, and an unlocked position wherein the handle and locking lever are rotated approximately 180° in a counterclockwise direction. The limits of movement of the locking lever are defined by a pair of upstanding pins 60 and 61 integral with the base member 20. The pin 60 limits movement of the lever to the locked position and the pin 61 limits movement of the locking lever to an unlocked position. The locking lever 22 is yieldably held in either of these positions by means of a flat spring 65 held at its ends by a pair of U-shaped forms 66 and 67 on the underside of the planar top 26 of the base member. The spring is retained in these forms 66 and 67 by capture by the head of the headed plug 55, as shown in FIG. 4. Intermediate its ends, the spring 65 coacts with one or the other of a pair of opposite flat surfaces 70 and 71 formed at the lower end of the pin part 53 of the locking lever.

The locking lever 22 has a pair of cam surfaces with a first cam surface coacting with the bridge section 40 of the keeper member and the second cam surface coacting with the lug 45 of the keeper member.

The locking lever 22 has a smooth top surface which is free from shapes to collect dirt or other foreign matter and which are difficult to clean. The arcuate peripheral outer section thereof is sloped upwardly from a leading edge 80 to a high point 81 to form the first cam section. The high point 81 is in firm engagement with the underside of the bridge section 40 when the window is locked, as shown in FIGS. 1 and 2. As seen in FIG. 3, the leading edge 80 is defined by a part of a front face 85 of the locking lever. This structure enables the locking lever to enter the space beneath the bridge section 40, even though the window sash are not tightly drawn together in a vertical direction and, as the locking lever moves to the position shown in FIGS. 1 and 3, the top surface thereof engages the underside of

the bridge section to bring the meeting rails 14 and 15 to the same level.

The second cam surface for coacting with the lug 45 on the keeper member is in the form of a depending, peripheral flange 90 having an internal wall 91 which gradually approaches the pivot axis for the locking lever. As the locking lever is moved to the locking position shown in FIG. 3, the wall 91 will, at some point along its length, engage the lug 45 and, as shown in FIG. 3, draw the keeper member and base member together in a horizontal direction to bring the meeting rails 14 and 15 into abutting relation or draw a weatherstrip therebetween into tight compression.

With the structure disclosed herein, the locking lever 22 has a smooth, streamlined appearance, without any exposed, dirt-collecting surfaces which are difficult to clean and with the depending flange 90 contributing to the strength thereof whereby a peripheral section of the locking lever may be gradually inclined to form the first cam surface coacting with the bridge section 40 of the keeper member. This construction, along with the depending flange 90 coacting with the lug 45 on the keeper member, enables the sash lock to be manufactured economically of molded parts. The structure provides a better-appearing sash lock than presently available on the market and enables use of materials whereby the sash lock does not lose its surface finish, as commonly occurs with metal sash locks having surfaces which are plated or otherwise treated.

I claim:

1. A sash lock for double hung window sash with upper and lower sash comprising, a strike member attachable to the meeting rail of the upper sash and having a bridge section overlying and spaced from an upstanding locking lug, and a rotatable locking lever pivotally attachable to the meeting rail of the lower sash, said locking lever having a smooth continuous and non-grooved upper surface with an inclined peripheral edge to progressively wedge under said bridge section as the locking lever is pivoted toward locked position, and a downwardly depending flange on said locking lever and extending downwardly to the plane of said locking lug for engaging behind said locking lug during rotation of the locking lever to locked position.

2. A sash lock as defined in claim 1 wherein said depending flange is curved and shaped to be progressively at a shorter distance from the pivot point for the locking lever whereby said sash are drawn together as the locking lever is rotated to locked position.

3. A sash lock as defined in claim 2 including means to yieldably hold said locking lever in either locked or unlocked position.

4. A sash lock for double hung window sash including a base member, a locking lever pivotally mounted on said base member by means of a pivot pin, said locking lever having a pair of cam surfaces, one of said cam surfaces being defined by a peripheral section of a smooth continuous top surface of the locking lever with the peripheral section being arcuate and upwardly sloped from a leading edge thereof, the other of said cam surfaces being defined by a depending arcuate flange at the perimeter of said locking lever which starts at the same location as said leading edge and along its length gradually approaches said pivot pin, a keeper member having a lug and an overlying bridge section whereby rotation of said locking lever toward locked position causes the other cam surface to move behind said lug

5

and draw the keeper member toward the base member while said one cam surface moves beneath the bridge section and brings the keeper member and base member to a predetermined orientation lengthwise of the pivot pin.

5. A sash lock as defined in claim 4 wherein said parts are of plastic.

6. A sash lock as defined in claim 5 wherein said locking lever and keeper member are each formed as a unitary plastic member.

6

7. A sash lock as defined in claim 5 wherein said pivot pin has a pair of opposite flat surfaces with spring means mounted in the base member to coact therewith and hold the locking lever in either locked or unlocked position.

8. A sash lock as defined in claim 5 wherein a pair of integral spaced pins extend upwardly from the base member to limit the arc of movement of the locking lever.

\* \* \* \* \*

10

15

20

25

30

35

40

45

50

55

60

65