



US 20080099208A1

(19) **United States**

(12) **Patent Application Publication**
Moncus et al.

(10) **Pub. No.: US 2008/0099208 A1**

(43) **Pub. Date: May 1, 2008**

(54) **APPARATUS FOR PERFORMING WELL WORK ON FLOATING PLATFORM**

Publication Classification

(51) **Int. Cl.**
E21B 29/12 (2006.01)

(52) **U.S. Cl.** **166/338**

(57) **ABSTRACT**

(76) Inventors: **James Devin Moncus**, Lafayette, LA (US); **Joseph Hayden Miller**, Lafayette, LA (US); **Bryan Duhon**, Church Point, LA (US)

An apparatus for supporting a well intervention device connected to a well extending from a floating platform. The apparatus comprises a frame assembly having a first and second end, and wherein the first end is positioned on the platform. The apparatus includes a crown assembly attached to the second end of the frame assembly, a motion compensator member attached to the frame assembly for compensating for vertical movements of the platform, and a travel head having a first connector and a second connector, and wherein the first connector is attached to the compensator member and the second connector attaches the travel head to the well intervention device.

Correspondence Address:
C . Dean Domingue
U.S. Registered Patent Attorney
Perret Doise, APLC, Post Office Box 3408
Lafayette, LA 70502-3408

(21) Appl. No.: **11/588,174**

(22) Filed: **Oct. 26, 2006**

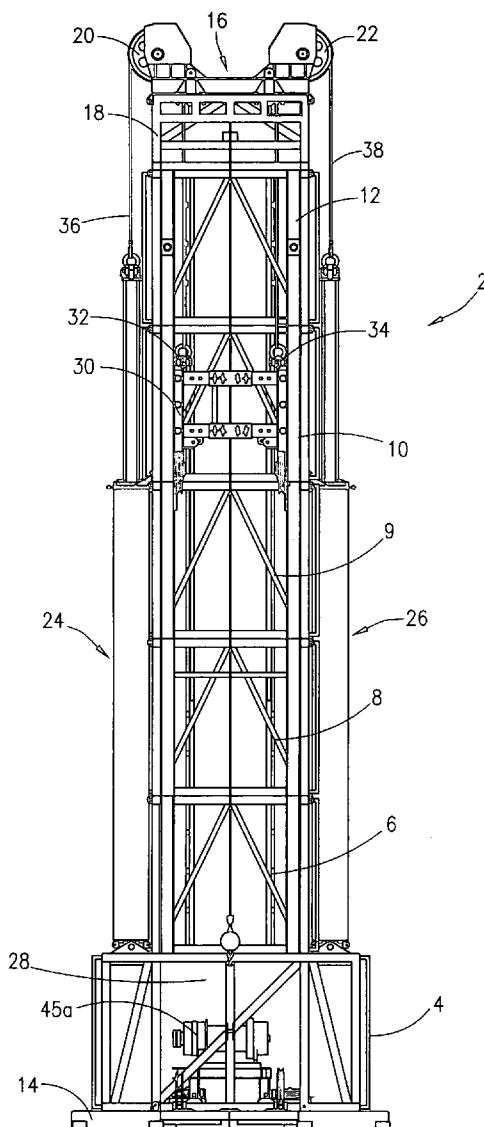

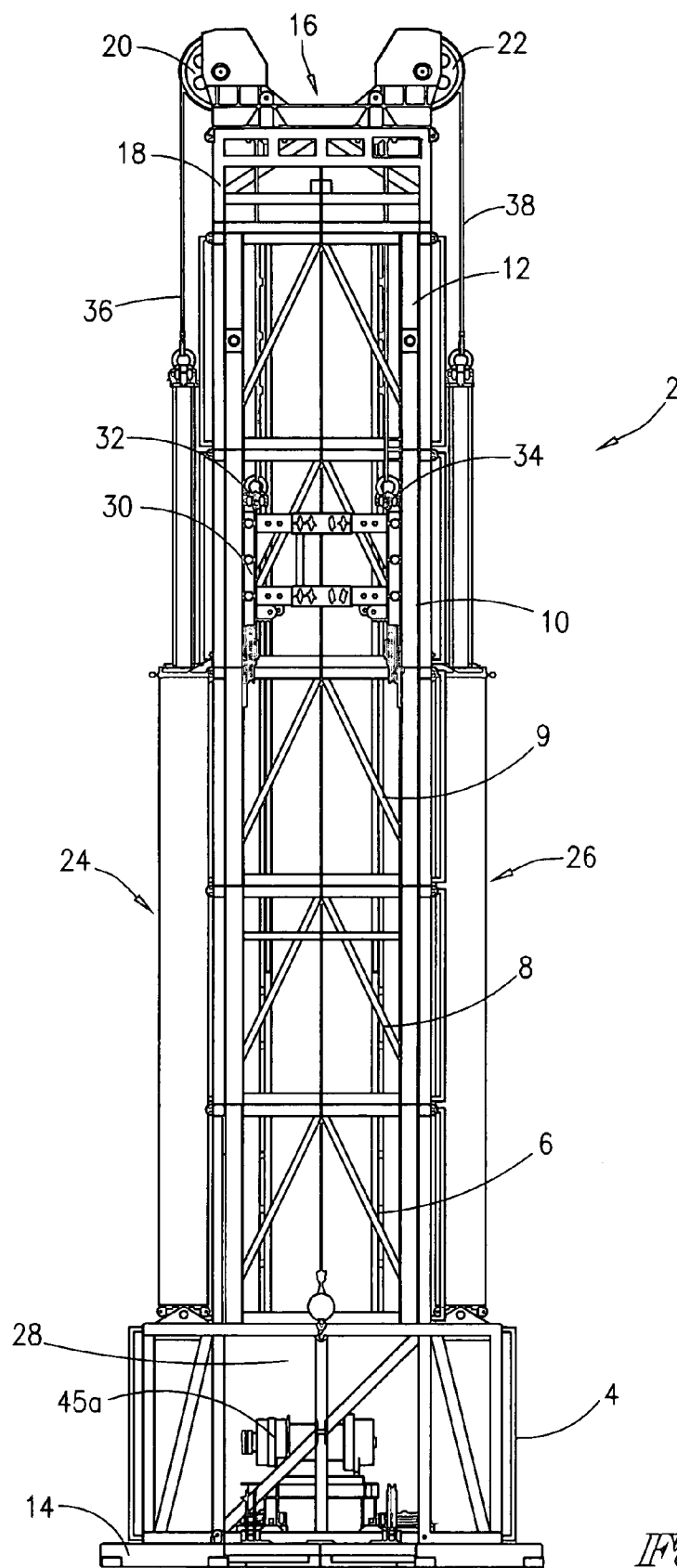

Fig. 1A

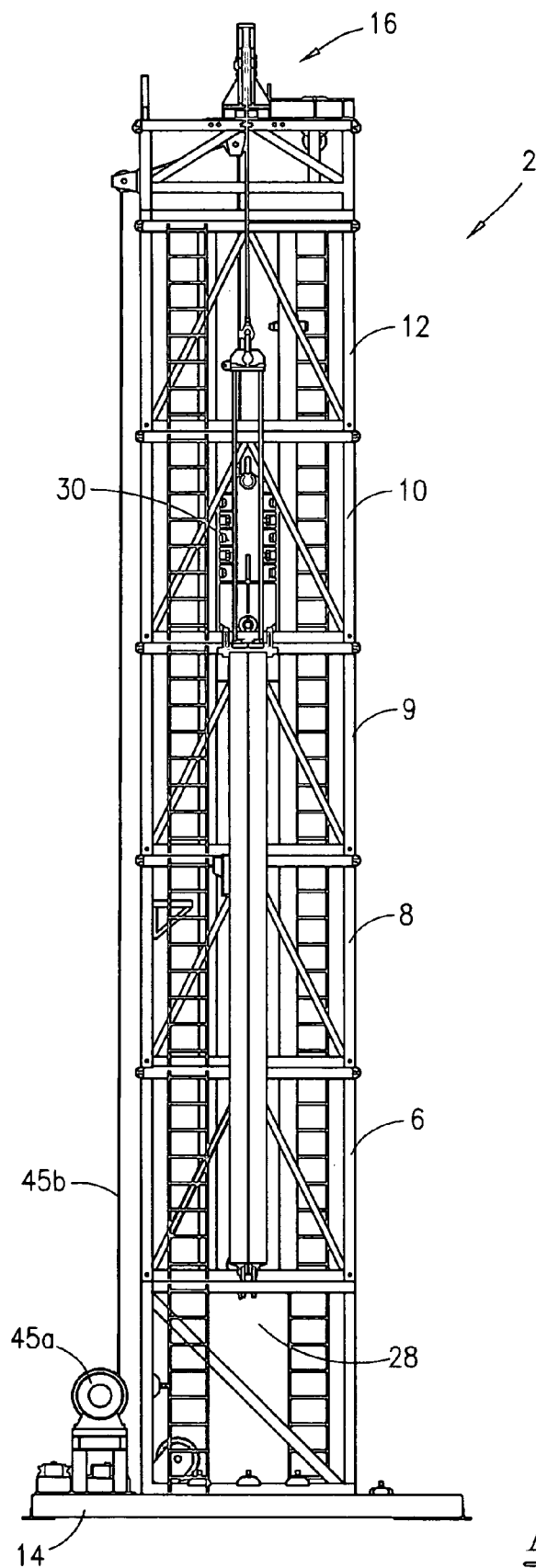

Fig. 11B

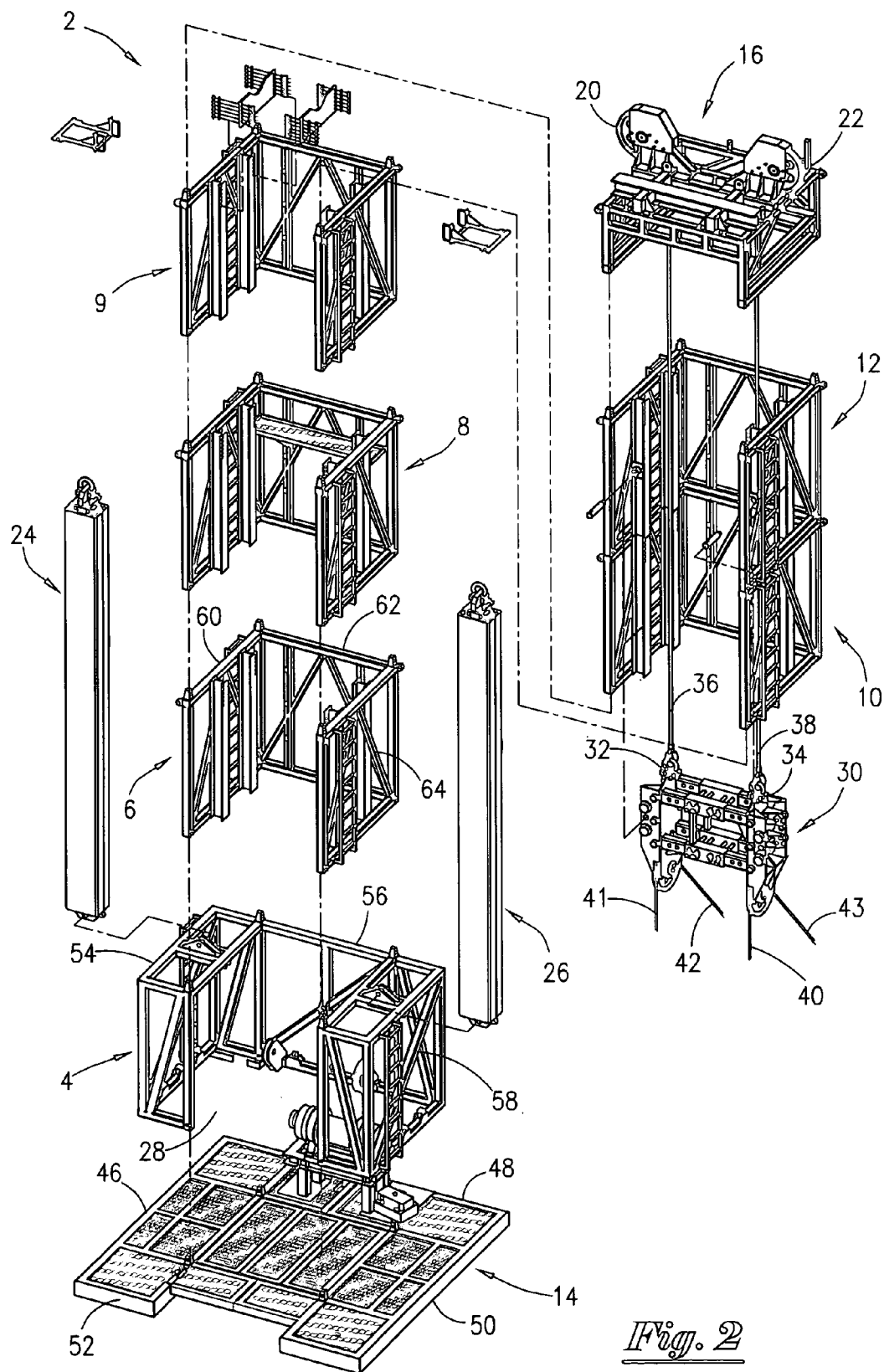

Fig. 2

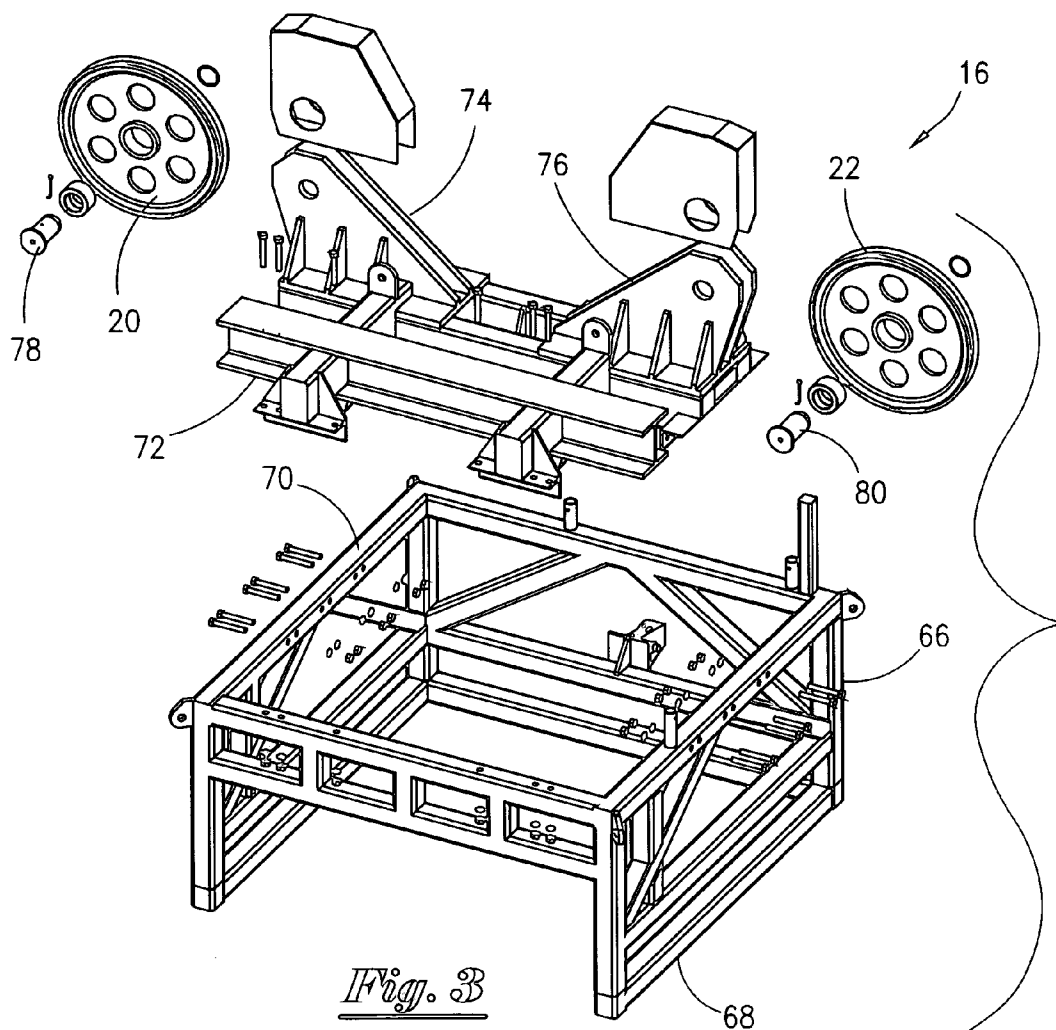

Fig. 3

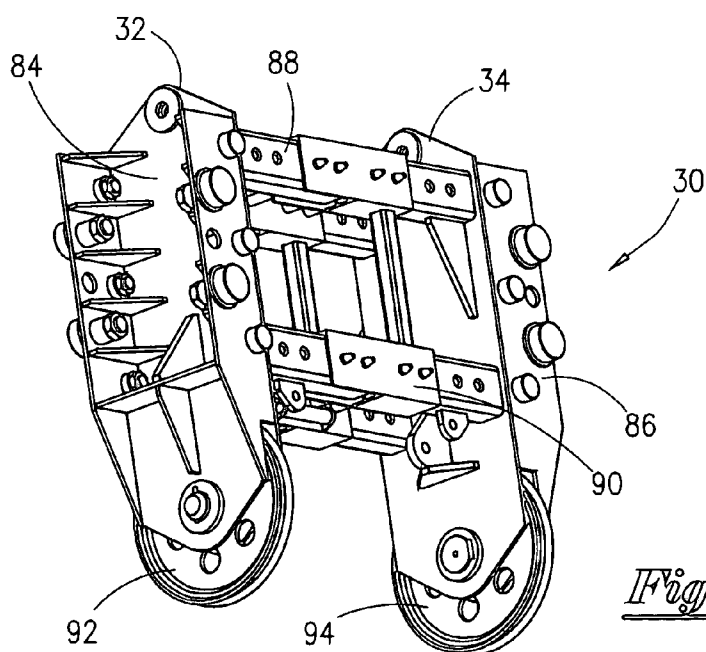

Fig. 4

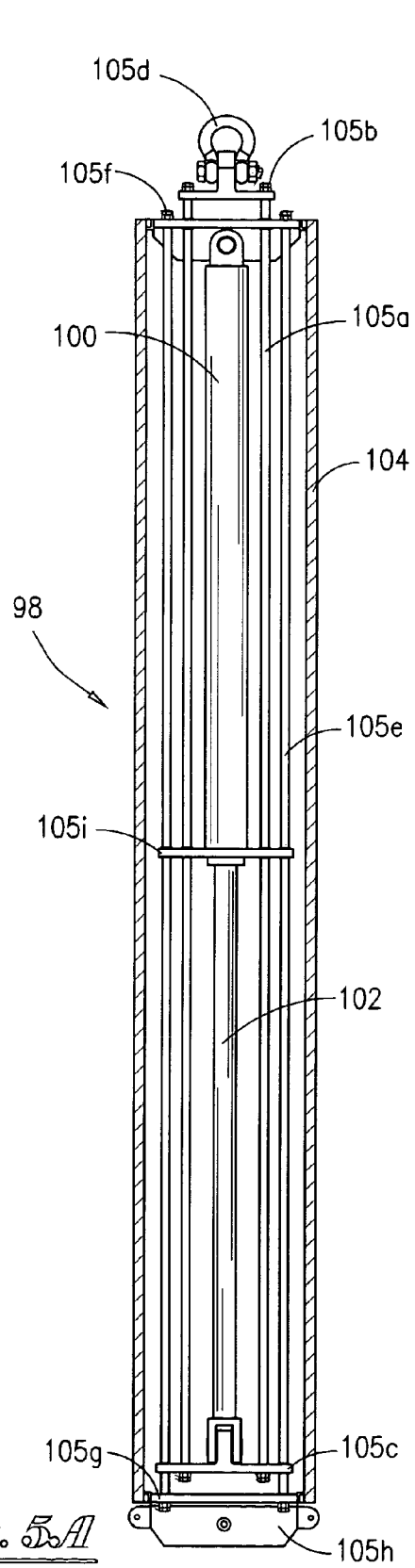

Fig. 5A

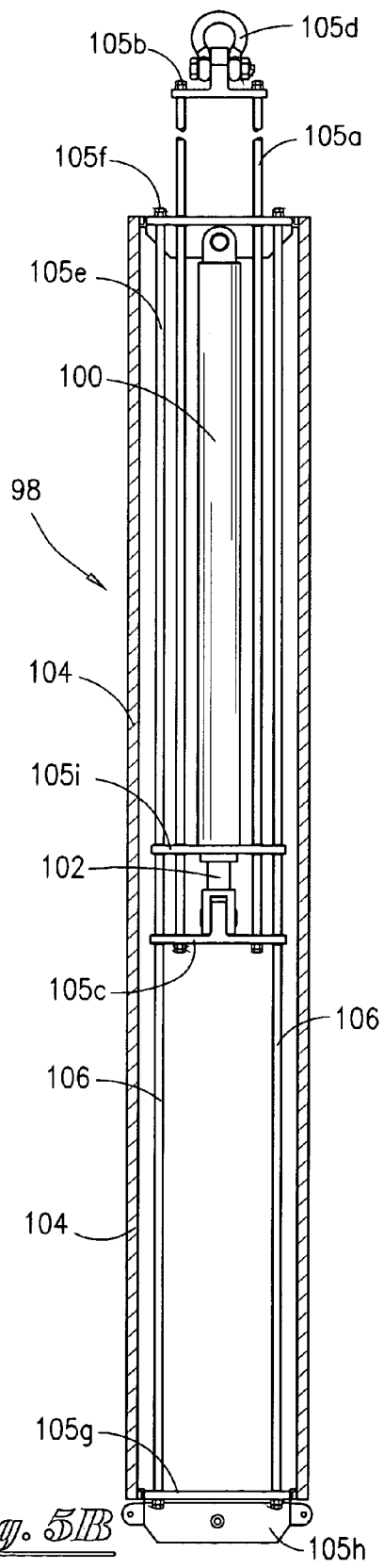

Fig. 5B

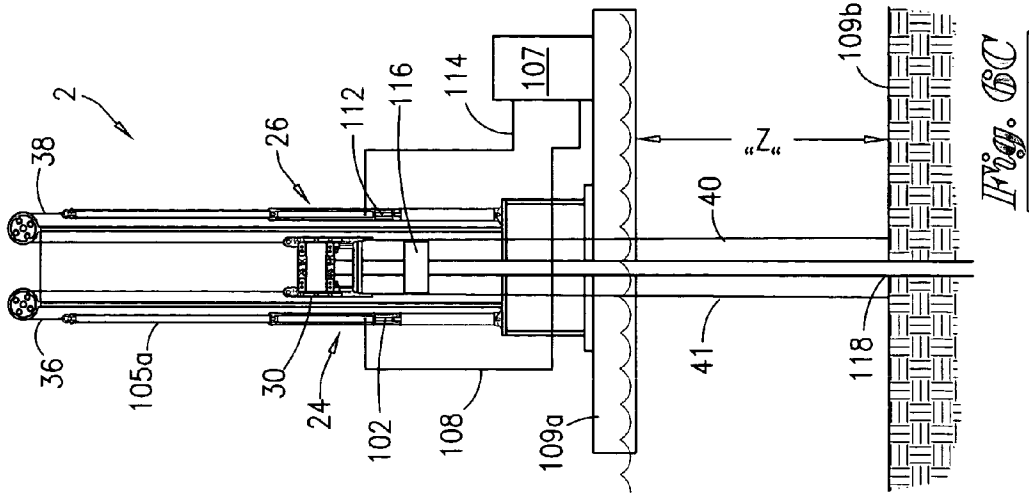

Fig. 6C

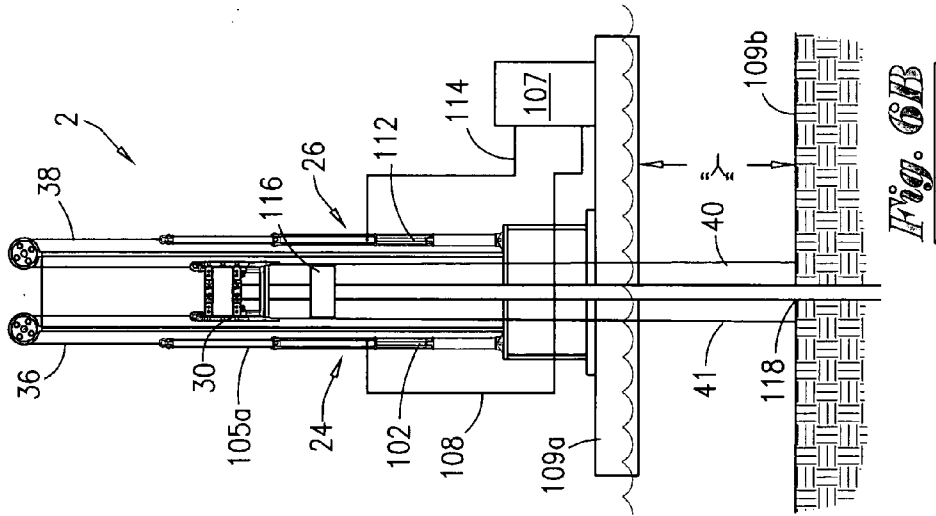

Fig. 6B

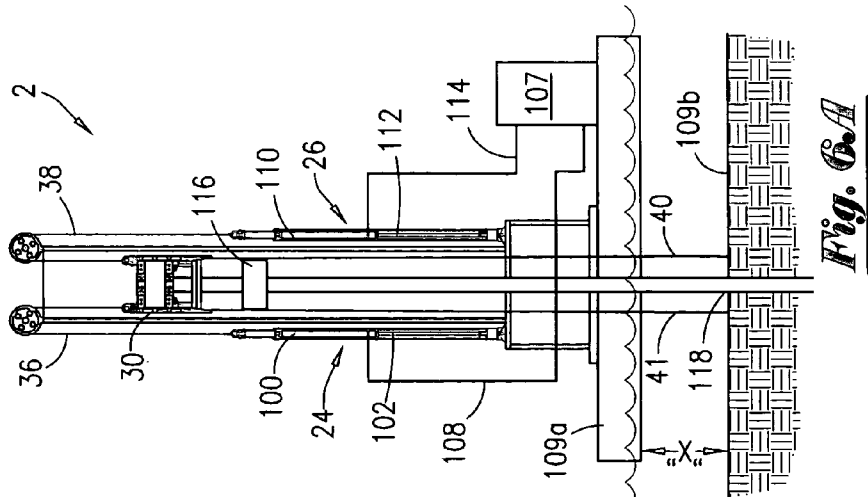

Fig. 6A

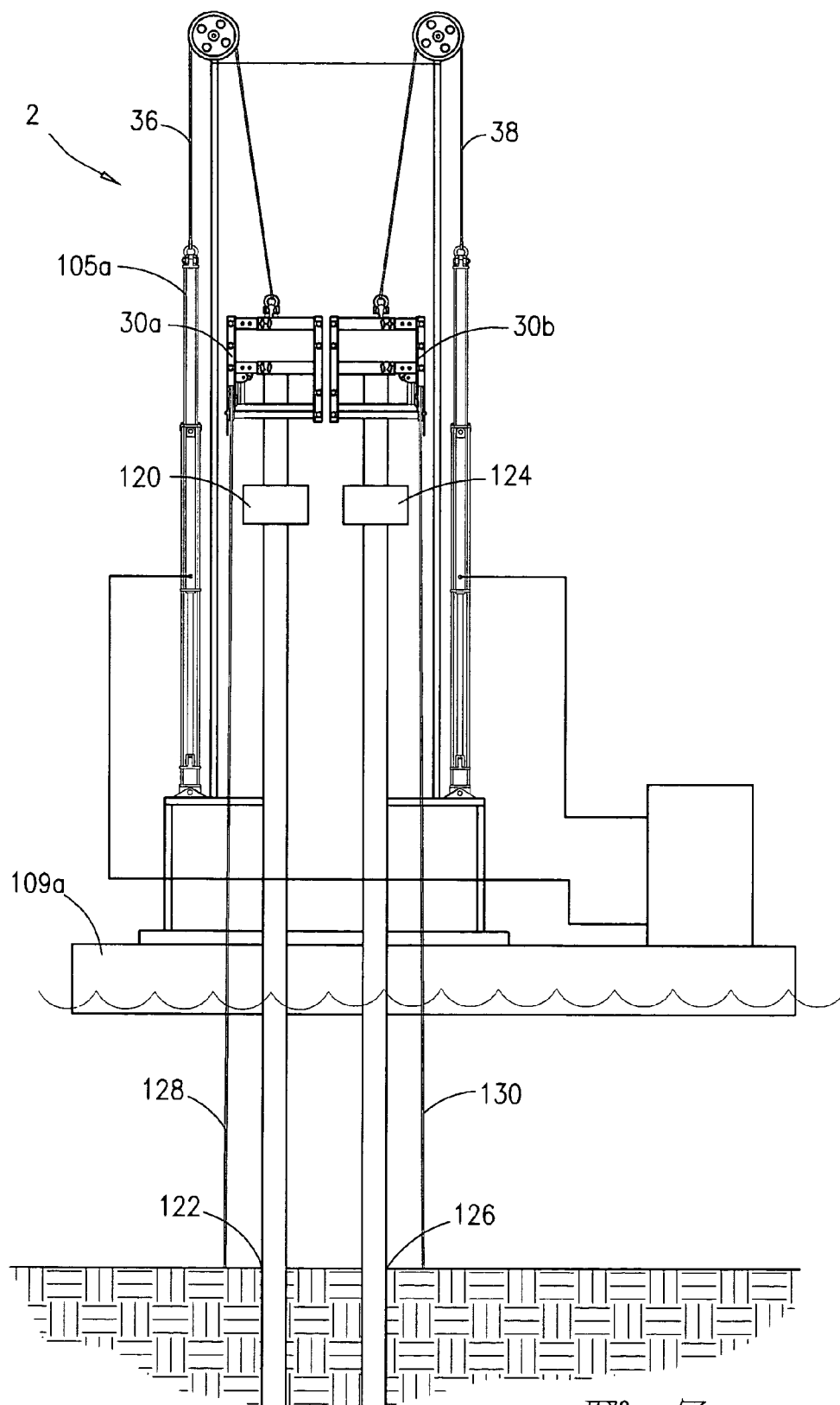

Fig. 7

APPARATUS FOR PERFORMING WELL WORK ON FLOATING PLATFORM

BACKGROUND OF THE INVENTION

[0001] This invention relates to an apparatus for performing well work on a floating platform. More particularly, but not by way of limitation, this invention relates to an apparatus for performing well work including a frame assembly with travel head and a method of use on a floating platform.

[0002] In the search for hydrocarbons, operators find it necessary to drill and complete wells in exotic locations. For instance, wells are being drilled in oceans wherein the water depth may be several thousand feet. As those of ordinary skill in the art will recognize, the wells are drilled from rigs that are floating on the ocean surface. Once drilled, the wells are completed, and production facilities are installed. During the course of drilling, completing and producing, numerous well intervention techniques must be employed. However, in the case of offshore wells, operational problems arise with the floating platforms, including but not limited to the currents, tides, winds and waves creating a constantly changing ocean surface. Hence, the normal movement of the ocean surface causes drilling, completing, and producing problems in these offshore environments.

[0003] One of the common problems encountered by floating offshore platforms is that the floating structure rises and lowers with the oscillation of the ocean surface. In many instances, a well extends from the sub-sea, and wherein the well will be connected to the platform via a marine riser. However, this can create significant stresses in the event that the floating platform (or some appurtenance to the platform) is attached to the well (and/or marine riser) since the floating platform rises and lowers with the ocean surface.

[0004] Therefore, there is a need for a device that will allow for well intervention work on offshore floating platforms. There is also a need for a system that will permit a frame assembly to be rigged up on floating platforms and allow for motion compensation while well work is ongoing. There is a further need for a frame assembly with a travel head that can aid in performing well work on floating platforms, including vessels. These, and many other needs, will be met by the invention herein described.

SUMMARY OF THE INVENTION

[0005] An apparatus for supporting a well intervention device connected to a well extending from a floating platform is disclosed. The apparatus comprises a frame assembly having a first end and a second end, wherein the first end is positioned on the platform, and a crown section assembly attached to the second end of the frame assembly. The apparatus further includes a motion compensator means, attached to the frame assembly, for compensating for vertical movements of the platform and means for supplying a power medium to the motion compensator means. The apparatus further comprises a travel head having a first connector and a second connector, and wherein the first connector is operatively attached to the motion compensator means and the second connector is attached to the well intervention device.

[0006] In one preferred embodiment, the motion compensator means is operatively attached to the first connector with the tension line leading from the motion compensator means and wherein the crown section assembly contains a

sheave that has placed therein a tension line leading from the motion compensator means and connected to the travel head.

[0007] The motion compensator means, in one preferred embodiment comprises a first motion compensator on a first side of the frame assembly; and, a second motion compensator on a second side of the frame assembly. The motion compensator includes a cylinder having a piston disposed therein, with the piston being responsive to the power medium.

[0008] As the platform rises, the piston retracts into the cylinder thereby keeping the travel head in the same position; and, as the platform lowers, the piston extends from the cylinder thereby keeping the travel head in the same position.

[0009] The frame assembly, in the most preferred embodiment, includes a plurality of frames, and wherein the plurality of frames are stackable in an array. In a preferred embodiment, the travel head includes an anchor line extending therefrom and wherein the anchor line is attached to the ocean floor.

[0010] In one preferred embodiment, a first well intervention device is attached to a first well and a second well intervention device is attached to a second well, and wherein the travel head is fixedly attached to the first and second well intervention device.

[0011] Additionally, the first motion compensator may include a first tension line leading therefrom, with the first tension line being led to a first sheave positioned in the crown section assembly; and wherein the second motion compensator has a second tension line leading therefrom, with the second tension line being led to a second sheave positioned in the crown section assembly.

[0012] A method for performing well intervention work on a floating platform is also disclosed. The floating platform has a first well extending there through, with the first well being connected to a first well intervention device. The method comprises providing an apparatus for supporting the first well intervention device, the apparatus including a frame having a bottom end and a top end, wherein the bottom end is positioned on the platform; a crown assembly attached to the top end of the frame; and, a cylinder, attached to the frame, with a piston extending therefrom.

[0013] The method includes attaching a travel head, located within the frame, to a tension line extending from the cylinder, attaching the travel head to the first well intervention device, and positioning the tension line through a sheave, with the sheave being attached to the top end of the frame. The method further includes retracting the piston into the cylinder as the ocean and platform rises and extending the tension line with the piston so that as the platform rises, the tension line remains under tension. The method further includes maintaining the travel head in a stationary position relative to the first well as the floating platform and frame rise with the ocean, and performing the well intervention work with the first well intervention device while the first well intervention device remains in the stationary position.

[0014] As the surface of the ocean lowers, the method further comprises lowering the floating platform as the surface of the ocean lowers, extending the piston from the cylinder, contracting the tension line so that the tension line remains in tension, and maintaining the travel head in a stationary position relative to the well as the floating platform and the frame lower with the ocean.

[0015] In one preferred embodiment, the platform further contains a second well disposed there through, and wherein the first well intervention device is attached to the first well and a second well intervention device is attached to the second well. The travel head is fixedly attached to the first and the second well intervention device and wherein the method further comprises performing well intervention work on the first well utilizing the first well intervention device and performing well intervention work on the second well utilizing the second well intervention device.

[0016] An advantage of the present invention includes use of the frame assembly on a floating offshore platform. Another advantage of the present invention is that the frame assembly, sometimes referred to as a tower, can be used to lift and lower various tools and equipment within a working window area of the frame assembly. The type of work includes rigging up and rigging down well intervention devices such as coiled tubing injector heads, lubricators, and blow out preventors. Another advantage is that the apparatus can be simultaneously used on two wells.

[0017] A feature of the present disclosure is the motion compensator system. In the most preferred embodiment, two motion compensators are arranged in opposite planes relative to the frame assembly's center. Another feature is the travel head that is attached to the motion compensator system and that is also attached to a well intervention device such as a wireline lubricator, a coiled tubing injector head, blow out preventor, etc. Yet another feature is that the frame, in the preferred embodiment, is made up of various modules that are structurally stacked to a desired height.

BRIEF DESCRIPTION OF THE DRAWINGS

[0018] FIG. 1A is a front general layout view of the most preferred embodiment of the well intervention frame assembly of the present invention.

[0019] FIG. 1B is a side view of the frame assembly embodiment seen in FIG. 1A.

[0020] FIG. 2 is an exploded view of the frame assembly embodiment seen in FIG. 1A.

[0021] FIG. 3 is an exploded view of the most preferred embodiment of the crown section assembly.

[0022] FIG. 4 is a perspective view of the most preferred embodiment of the travel head.

[0023] FIG. 5A is a partial cross-sectional view of a motion compensator cylinder and piston.

[0024] FIG. 5B is the motion compensator cylinder and piston seen in FIG. 5A with the piston disposed within the cylinder.

[0025] FIG. 6A is a schematic illustration of the system of the most preferred embodiment with the platform in a first position relative to the ocean floor in an extended position.

[0026] FIG. 6B is a sequential schematic illustration of the system seen in FIG. 6A with the platform in a second position relative to the ocean floor in a contracted position.

[0027] FIG. 6C is a sequential schematic illustration of the system seen in FIG. 6B with the platform in a third position relative to the ocean floor.

[0028] FIG. 7 is a schematic illustration of the system use with dual well intervention devices connected to dual wells.

DETAILED DESCRIPTION OF THE PREFERRED EMBODIMENTS

[0029] Referring now to FIG. 1A, a front general layout view of the most preferred embodiment of the well intervention frame assembly 2 will now be described. In the most preferred embodiment, the frame assembly 2 consist of a series of modular frames, sometimes referred to as a tower. As shown in FIG. 1A, the modular frames can be stacked one on top of the other in order to reach a specific height. FIG. 1A depicts the base frame 4, the modular frame 6, the modular frame 8, the module frame 9, the modular frame 10, and the modular frame 12. The modules are commercially available from Devin International Inc. under the name Track Stack Jr. Generally, the individual modular frames have three (3) vertical sides, and wherein one side is open in order to allow a window for entry (sometimes referred to as a working window area). As seen in FIG. 1A, the base frame 4 has a larger footprint (i.e. larger width) in order to better distribute the vertical load which leads to stability of the frame assembly 2.

[0030] The frame assembly 2 has a first end and a second end, and wherein the first end (bottom end) has the template 14 that serves as the base for the base frame 4. The second end (top end) includes the crown section 16, and wherein the crown section 16 includes a rectangular frame, seen generally at 18, and wherein a first sheave 20 is attached to the rectangular frame 18 and a second sheave 22 that is attached to the rectangular frame 18. The rectangular frame 18 is fixedly attached to the modular frame 12 by conventional means, such as nuts and bolts or welding, as well understood by those of ordinary skill in the art.

[0031] FIG. 1A also depicts the motion compensator means, attached to the frame assembly 2, for compensating for vertical movements of the platform. More specifically, a first motion compensator means 24 is attached on a first side of the frame assembly 2 and a second motion compensator means 26 is attached on a second side of the frame assembly 2. The motion compensators will be attached via conventional means such as nuts and bolts, or welding.

[0032] The front view of FIG. 1A also depicts the window working area, seen generally at 28. Within this working window 28 will be the travel head 30 (sometimes referred to as the block) that has the first connector 32 and the second connector 34. The tension line 36 is connected to the connector 32 and is feed through the sheave 20 to the motion compensator means 24. The tension line 38 is connected to connector 34 and is feed through the sheave 22 to the motion compensator means 26. The travel head 30 will be attached, via a connector, to a well intervention device as will be explained later in greater detail. The tower 2 will be positioned on a floating platform, and wherein a subterranean well (not shown in this view) will extend from the platform. As understood by those of ordinary skill in the art, the well intervention device will be operatively attached to the well.

[0033] Referring now to FIG. 1B, a side view of the tower 2 seen in FIG. 1A will now be described. It should be noted that like numbers appearing in the various figures refer to like components. FIG. 1B depicts the stacked modular frames 6, 8, 9, 10, 12, along with the crown section 16. The travel block 30 is shown disposed within the working window 28 as previously described. FIG. 1B also shows a

winch **45a** and line **45b**, which is attached to the template **14**, and wherein the winch **45a** is used for rig-up, rig-down and operational purposes.

[0034] An exploded view of the tower **2** is illustrated in FIG. **2**. The template **14** is configured to cooperate and engage with the base frame **4**. The template **14** has four sides, seen generally at **46**, **48**, **50**, **52**. FIG. **2** also depicts various connecting members. The base frame **4** will have three sides, namely sides **54**, **56**, **58**, along with the open side previously mentioned as the window working area **28**. The base frame **4** will be fixedly attached to the template **14**. The modular frame **6** also has three sides, namely sides **60**, **62**, **64**, along with the open side previously mentioned as the window working area. The modular frames **8**, **9**, **10** and **12** are essentially identical as modular frame **6**, and therefore, their description will not be repeated. In the preferred embodiment, the template **14** is attached to the modular frame **4**; the modular frame **4** is attached to the modular frame **6**; the modular frame **6** is attached to modular frame **8**; modular frame **8** is attached to modular frame **9**; modular frame **9** is attached to modular frame **10**; modular frame **10** is attached to modular frame **12**; and modular frame **12** is attached to crown assembly section **16**. As will be appreciated by those of ordinary skill in the art, the exact number of modular frames will be dependent on the desired height of the tower **2**. Accordingly, less or more modular frames may be included.

[0035] The sheaves **20** and **22** are depicted, and wherein the tension line **36** will be directed through sheave **20** and the tension line **38** will be directed through sheave **22**. In turn, the tension lines **36**, **38** will be connected to the travel block **30**. As seen in FIG. **2**, the travel block **30** also contains the first connector **32** and the second connector **34**. The anchor lines **40**, **41** are attached to the travel block **30** at one end and at the other end to the ocean floor and a pair of working lines **42**, **43** are operatively connected to the air tuggers and are used for operational, remedial work utilizing the tower **2**, such as rigging-up and rigging-down equipment.

[0036] Referring now to FIG. **3**, an exploded view of the most preferred embodiment of the crown section assembly **16** will now be disclosed. The crown section assembly **16** includes the rectangular support frame **66**, and wherein the frame **66** contains an underside **68** that will be fixedly connected to the modular frame **12** and a topside **70**. The crown section assembly **16** further includes the weldment member **72** and wherein the weldment member **72** is fixedly connected to the support frame **66**. The angled braces **74**, **76** are fixedly connected to the weldment member **72**, and as shown, the sheave **20** is rotatably connected via bushing **78** to the brace **74** and the sheave **22** is fixedly connected via bushing **80** to the brace **76**.

[0037] A perspective view of the most preferred embodiment of the travel head **30** is illustrated in FIG. **4**. The travel head **18** includes the vertical member **84** and the vertical member **86**, as well as the horizontal connecting member **88** and the horizontal connecting member **90** are also depicted, and wherein the connector members can be used to connect the travel head **30** to the well intervention device. A sheave **92** is mounted on the member **84** and a sheave **94** is mounted on the member **86**. The purpose of sheaves **92**, **94** is to connect to the anchor lines **40**, **41** to the well intervention device as well as the sea floor which in turn holds the travel head **30** stationary relative to the ocean floor.

[0038] Referring now to FIG. **5A**, a partial cross-sectional view of a motion compensator cylinder and piston, such as generally seen in FIG. **1A** as numeral **24**, will now be described. In the preferred embodiment, the assembly **98** includes a cylinder **100** and a movable piston **102** disposed therein. The piston **102** has an extended position and a contracted position. It should be noted that a protective cage is included in one embodiment, seen generally at **104**, and wherein the protective cage is a cylindrical member that surrounds the cylinder **100** and is attached to the frame assembly. The piston **102** will have travel cage **105a** operatively attached thereto, and wherein the travel cage **105a** has top end eye bracket **105b** and bottom end bracket **105c**. The pad eye **105d**, which is attached to the eye bracket **105b**, is attached to the tension line. The guide cage **105e** is attached to the protective cage **104** via top plate **105f** and bottom plate **105g**, and hence, guide cage **105e** is attached to the protective cage **104** via conventional means such as welding. The bottom member **105h** will be attached to the platform **109a** (not seen in this view) and the protective cage **104**. The contraction and extension of piston **102** will in turn cause the travel cage **105a** to extend and contract out of the protective cage **104**, which in turn causes pad eye **105d** to extend and contract. The tension line is connected to the pad eye **105d**. Hence, the protective cage **104** would aid in protecting and guarding the piston **102** and cylinder **100** from damage during operations, as well as providing an anchoring mechanism for the cylinder **100** and piston **102** during operations.

[0039] FIG. **5B** is the motion compensator cylinder and piston seen in FIG. **5A** with the piston **102** disposed within the cylinder **100**. Please note that the motion compensator means **26** is of similar construction and will not be repeated. The piston **102** is extended and contracted via a power pack means, that will be described later. Note that plate **105i**, with holes there through for placement of the individual cage rods, is included to separate the various rods of the cages during traveling movement of the piston **102**.

[0040] Referring now to FIGS. **6A**, **6B**, and **6C**, a sequential schematic illustration of the apparatus, including the tower **2**, various components, and compensation system, of the most preferred embodiment is shown with a gradually rising ocean level such that the pistons go from a extended state to a contracted state. It should be noted that a motion compensator was described in U. S. Pat. No. 6,929,071, entitled "Motion Compensation System and Method", assigned to Applicant, and is incorporated herein by express reference. As seen in FIG. **6A**, the floating platform **109a** contains the well intervention tower **2** along with the first motion compensator means **24** and the second motion compensator means **26**. The piston **102** extends from the cylinder **100**. The cylinder **100** is operatively connected to the power pack means **107** via line **108** (which would include input and output lines as understood by those of ordinary skill in the art) and wherein power pack means **107** delivers a power medium, which in the most preferred embodiment will be a nitrogen gas, to the cylinder **100**. In another embodiment, the power medium may be a hydraulic fluid. The depth from the platform **109a** to the ocean floor **109b** is denoted by the letter "X"

[0041] The second motion compensator means **26** contains the cylinder **110** with the piston **112** extending therefrom. The cylinder **110** is operatively connected to the power pack means **107** via line **114** (which would include input and output lines). In the most preferred embodiment, the pistons

102, 112 are connected to base frame **4** (for instance, member **105h** is connected to the platform **109a**), and the cylinders **100, 110** (for instance, via pad eyes **105d**) are connected to the tension lines **36, 38**, respectively, as seen in FIGS. **5A** and **5B**. It should be noted that it is possible to have an embodiment wherein the piston and cylinder arrangement is reversed so that the pistons are connected to the tension lines. However, as seen in FIGS. **6A-6C**, the pistons, when extending downward, push down on the floating platform **109a** which aids in keeping the tension lines in tension . . . FIG. **6A** represents the situation wherein the pistons have been extended . . . due to the action of the power medium from the power pack means **107**. The tension lines **36, 38** connect to the travel head **30** and to the cylinders **100, 110**, respectively, and wherein the tension lines **36, 38** are maintained in tension in order to support the travel head **30**. FIG. **6A** shows the anchor line **40, 41** attaching the travel head **30** to the ocean floor **109b**.

[0042] Operators can attach well intervention devices, denoted by the numeral **116** in FIGS. **6A, 6B**, and **6C** to the travel head **30**, as previously noted. The well intervention device **116** is fixedly attached to the well **118**. The operator can perform well intervention work in an oscillating sea as per the present disclosure. Well intervention devices include coiled tubing injector heads, blow out preventor stacks, and lubricators.

[0043] FIG. **6B** is a simplified schematic illustration of the system seen in FIG. **6A** as the surface of the ocean has risen, and wherein the depth is denoted by the letter “Y”, and wherein the pistons are in a more contracted position relative to FIG. **6A**. Hence the pistons **102, 112** are partially extending from the cylinders **100, 110** respectively, due to the action of the power pack means **107** injecting nitrogen gas into the cylinders **100, 110**. FIG. **6B** represents the situation wherein the floating platform has risen (due to the ocean level rising), and therefore, the power pack means **107** causes the pistons **102, 112** to partially extend thereby pushing down on the floating platform **109a**. At the same time, the travel cage **105a** has extended. The tension lines are connected to the travel cages. As previously noted, tension lines **36, 38** are still maintained in tension due to the compensating effect, which in turn maintains the travel head **30** in tension and stationary.

[0044] FIG. **6C** represents the sequential illustration wherein the ocean surface has again risen and the depth has increased to the depth denoted by the letter “Z”. As seen in FIG. **6C**, the pistons **102, 112** are in a fully contracted state . . . due to the action of the power pack means **107** injecting the nitrogen gas into the cylinders **100, 110**. The travel cage **105a** is fully extended. The tension lines **36, 38** are still maintained in tension due to the compensating effect, which in turn maintains the travel head **30** in tension and stationary, as previously noted.

[0045] FIG. **7** is a schematic illustration of the frame assembly and system in use with dual well intervention devices connected to dual wells. More specifically, FIG. **7** depicts the tower **2** disposed on the floating platform **109a**. The tension lines **36, 38** are also attached to travel cages (i.e. **105a**) of the pistons **102, 112**, respectively. In this embodiment, there are two travel heads, namely travel head **30a** independently attached to tension line **36**, and travel head **30b** independently attached to the tension line **38**. However, it is within the scope of this disclosure that in the case of dual well work, the single travel head **30** can also be used.

[0046] FIG. **7** depicts a first well intervention device **120** attached to a first well **122**, and a second well intervention device **124** attached to a second well **126**. The well intervention device **120** is attached to the travel head **30a**, and the well intervention device **124** is attached to the travel head **30b**, as shown. Anchor lines **128, 130** from the travel heads **30a, 30b** to the sea floor are also shown.

[0047] While the particular invention as herein shown and disclosed in detail is fully capable of obtaining the features and providing the advantages hereinbefore stated, it is to be understood that this disclosure is merely illustrative of the presently preferred embodiments of the invention and that no limitations are intended other than as described in the appended claims.

We claim:

1. An apparatus for supporting a well intervention device connected to a well extending from a floating platform, the apparatus comprising:

- a frame assembly having a first end and a second end, wherein said first end is positioned on the platform;
- a crown section assembly attached to the second end of said frame assembly;
- a motion compensator means, attached to said frame assembly, for compensating for vertical movements of the platform;
- a travel head having a first connector and a second connector, and wherein said first connector is attached to said compensator means and said second connector attaches said travel head to the well intervention device.

2. The apparatus of claim **1** wherein said motion compensator means comprises:

- a first motion compensator on a first side of said frame assembly;
- a second motion compensator on a second side of said frame assembly;
- power pack means for supplying a power medium to said first and said second motion compensator.

3. The apparatus of claim **1** wherein said motion compensator means comprises:

- a cylinder having a piston disposed therein;
- power pack means for supplying a power medium to said cylinder and wherein said piston is responsive to said power medium.

4. The apparatus of claim **1** wherein said motion compensator means includes a tension line extending therefrom and wherein said tension line is connected to said travel head.

5. The apparatus of claim **4** wherein said crown section assembly contains a sheave that has placed therein said tension line.

6. The apparatus of claim **1** wherein said motion compensator means comprises a cylinder having a piston disposed therein and wherein as said platform raises, said piston retracts into said cylinder thereby keeping said travel head in the same position and as said platform lowers, said piston extends from said cylinder thereby keeping said travel head stationary relative to the well intervention device.

7. The apparatus of claim **6** wherein said frame assembly includes a plurality of frames, and wherein said plurality of frames are stackable in an array to a desired height.

8. The apparatus of claim **7** wherein the well intervention device includes a first well intervention device that is attached to a first well and a second well intervention device

that is attached to a second well, and wherein said travel head is fixedly attached to said first and said second well intervention device so that the well intervention work can be performed.

9. An apparatus for supporting a first well intervention device connected to a well extending from a floating platform comprising:

- a frame assembly having a first end and a second end, wherein said first end is positioned on the platform;
- a crown section assembly attached to the second end of said frame assembly;
- a motion compensator member, attached to said frame assembly, for compensating for vertical movements of the platform;
- means for supplying a power medium to said motion compensator member;
- a travel head having a first connector and a second connector, and wherein said first connector is operatively attached to said motion compensator member and said second connector is attached to the first well intervention device.

10. The apparatus of claim 9 wherein said motion compensator member is operatively attached to said first connector with a tension line leading from said motion compensator member and wherein said crown section assembly contains a sheave that has placed therein said tension line leading from said motion compensator member and connected to said travel head.

11. The apparatus of claim 9 wherein said motion compensator member comprises:

- a first motion compensator on a first side of said frame assembly; and,
- a second motion compensator on a second side of said frame assembly.

12. The apparatus of claim 10 wherein said motion compensator member comprises:

- a cylinder having a piston disposed therein, said piston being responsive to the power medium.

13. The apparatus of claim 12 wherein said travel head includes an anchor line extending therefrom and wherein said anchor line is attached to the ocean floor.

14. The apparatus of claim 13 wherein as said platform raises, said piston retracts into said cylinder thereby keeping said travel head in the same position and as said platform lowers, said piston extends from said cylinder thereby keeping said travel head in the same position.

15. The apparatus of claim 14 wherein said frame assembly includes a plurality of frames, and wherein said plurality of frames are stackable in an array.

16. The apparatus of claim 15 wherein said first well intervention device is attached to a first well and a second well intervention device is attached to a second well, and wherein said travel head is fixedly attached to said first and said second well intervention device.

17. The apparatus of claim 11 wherein said first motion compensator has a first tension line leading therefrom, said first tension line being led to a first sheave positioned in said crown section assembly; and wherein said second motion compensator has a second tension line leading therefrom, said second tension line being led to a second sheave positioned in said crown section assembly.

18. A method for performing well intervention work on a floating platform, the floating platform having a first well extending there through, with the first well being connected to a first well intervention device, the method comprising:

- providing an apparatus for supporting the first well intervention device, the apparatus including a frame having a bottom end and a top end, wherein said bottom end is positioned on the platform; a crown assembly attached to the top end of said frame; a cylinder, attached to said frame, with a piston extending therefrom;
- attaching a travel head, located within said frame, to a tension line extending from the cylinder;
- attaching the travel head to the first well intervention device;
- positioning said tension line through a sheave, said sheave being attached to the crown assembly;
- retracting said piston into said cylinder as the ocean and platform rises;
- extending said tension line with said piston so that as said platform rises, the tension line remains under tension;
- maintaining said travel head in a stationary position relative to the first well as the floating platform and the frame rise with the ocean;
- performing the well intervention work with the first well intervention device while the first well intervention device remains in the stationary position.

19. The method of claim 18 wherein the surface of the ocean lowers and the method further comprises:

- lowering the floating platform as the surface of the ocean lowers;
- extending said piston from said cylinder;
- contracting said tension line so that the tension line remains in tension;
- maintaining said travel head in a stationary position relative to the well as the floating platform and the frame lower with the ocean.

20. The method of claim 19 wherein said platform further contains a second well disposed there through, and a second well intervention device is attached to the second well and wherein said travel head is fixedly attached to the first and the second well intervention device and wherein the method further comprises:

- performing well intervention work on the first well utilizing the first well intervention device;
- performing well intervention work on the second well utilizing the second well intervention device.

* * * * *