

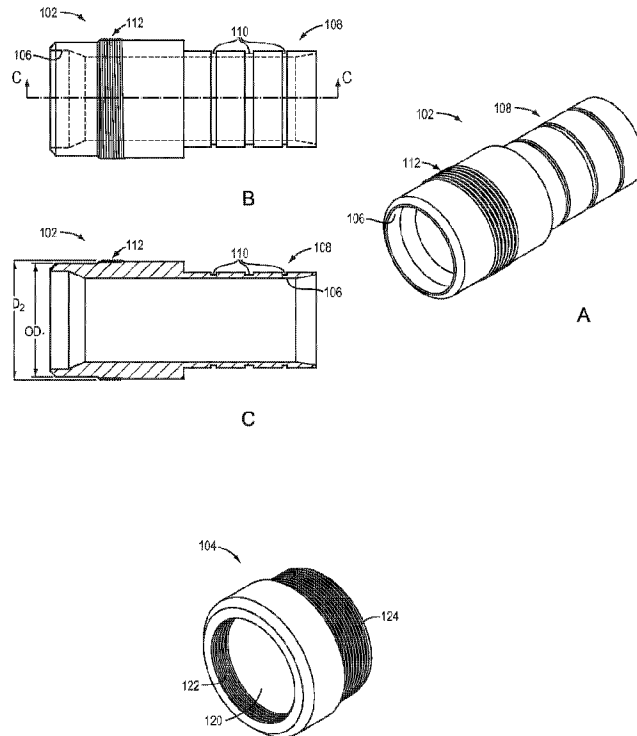

(86) Date de dépôt PCT/PCT Filing Date: 2013/08/12  
 (87) Date publication PCT/PCT Publication Date: 2014/02/13  
 (45) Date de délivrance/Issue Date: 2021/07/06  
 (85) Entrée phase nationale/National Entry: 2015/02/10  
 (86) N° demande PCT/PCT Application No.: US 2013/054533  
 (87) N° publication PCT/PCT Publication No.: 2014/026190  
 (30) Priorité/Priority: 2012/08/10 (US61/681,895)

(51) Cl.Int./Int.Cl. *E21B 17/04* (2006.01),  
*F16L 23/028* (2006.01), *F16L 33/18* (2006.01),  
*F16L 33/207* (2006.01), *F16L 33/22* (2006.01)  
 (72) Inventeur/Inventor:  
 ALLIN, D. KELLY, US  
 (73) Propriétaire/Owner:  
 NATIONAL OILWELL VARCO, L.P., US  
 (74) Agent: RICHES, MCKENZIE & HERBERT LLP

(54) Titre : RACCORDS DE TUBULURE ENROULEES COMPOSITES  
 (54) Title: COMPOSITE COILED TUBING CONNECTORS



(57) **Abrégé/Abstract:**

The invention includes a connector (100) for coupling to a composite pipe, and methods for forming the same. The connector has a seal carrier (102) forming a fluid passage that is made of a first material and that includes a seal receiving portion (108) configured to receive at least one seal and a first coupling surface on an outer seal carrier surface. The connector also has an interconnect (104) with a passage configured to receive the seal carrier (102) that is made of a second material and includes a second coupling surface on an inner interconnect surface configured for coupling with the first coupling surface to connect the seal carrier (102) and the interconnect (104) and a third coupling surface on an outer interconnect surface.

(12) INTERNATIONAL APPLICATION PUBLISHED UNDER THE PATENT COOPERATION TREATY (PCT)

(19) World Intellectual Property  
Organization  
International Bureau(10) International Publication Number  
**WO 2014/026190 A1**(43) International Publication Date  
13 February 2014 (13.02.2014)

## (51) International Patent Classification:

*E21B 17/04* (2006.01)      *F16L 33/207* (2006.01)  
*F16L 23/028* (2006.01)    *F16L 33/22* (2006.01)  
*F16L 33/18* (2006.01)

## (21) International Application Number:

PCT/US2013/054533

## (22) International Filing Date:

12 August 2013 (12.08.2013)

## (25) Filing Language:

English

## (26) Publication Language:

English

## (30) Priority Data:

61/681,895      10 August 2012 (10.08.2012)      US

(71) Applicant: NATIONAL OILWELL VARCO, L.P.  
[US/US]; 7909 Parkwood Circle Drive, Houston, TX 77036 (US).

(72) Inventors: ALLIN, D., Kelly; 11523 Sageking Drive, Houston, TX 77089 (US). MAKSELON, Christopher, E.; 18611 Mosshill Estates Ln, Cypress, TX 77429 (US).

(74) Agents: KAVANAUGH, Theresa, C. et al.; Goodwin Procter LLP, Exchange Place, Boston, MA 02109 (US).

(81) Designated States (unless otherwise indicated, for every kind of national protection available): AE, AG, AL, AM,

AO, AT, AU, AZ, BA, BB, BG, BH, BN, BR, BW, BY, BZ, CA, CH, CL, CN, CO, CR, CU, CZ, DE, DK, DM, DO, DZ, EC, EE, EG, ES, FI, GB, GD, GE, GH, GM, GT, HN, HR, HU, ID, IL, IN, IS, JP, KE, KG, KN, KP, KR, KZ, LA, LC, LK, LR, LS, LT, LU, LY, MA, MD, ME, MG, MK, MN, MW, MX, MY, MZ, NA, NG, NI, NO, NZ, OM, PA, PE, PG, PH, PL, PT, QA, RO, RS, RU, RW, SA, SC, SD, SE, SG, SK, SL, SM, ST, SV, SY, TH, TJ, TM, TN, TR, TT, TZ, UA, UG, US, UZ, VC, VN, ZA, ZM, ZW.

(84) Designated States (unless otherwise indicated, for every kind of regional protection available): ARIPO (BW, GH, GM, KE, LR, LS, MW, MZ, NA, RW, SD, SL, SZ, TZ, UG, ZM, ZW), Eurasian (AM, AZ, BY, KG, KZ, RU, TJ, TM), European (AL, AT, BE, BG, CH, CY, CZ, DE, DK, EE, ES, FI, FR, GB, GR, HR, HU, IE, IS, IT, LT, LU, LV, MC, MK, MT, NL, NO, PL, PT, RO, RS, SE, SI, SK, SM, TR), OAPI (BF, BJ, CF, CG, CI, CM, GA, GN, GQ, GW, KM, ML, MR, NE, SN, TD, TG).

## Published:

- with international search report (Art. 21(3))
- before the expiration of the time limit for amending the claims and to be republished in the event of receipt of amendments (Rule 48.2(h))

(54) Title: COMPOSITE COILED TUBING CONNECTORS

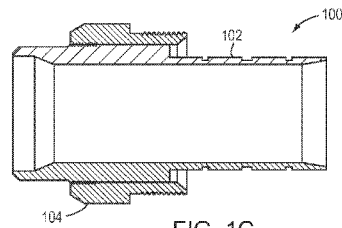

FIG. 1C

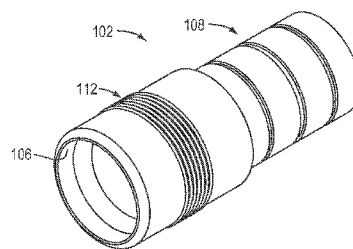

FIG. 2A

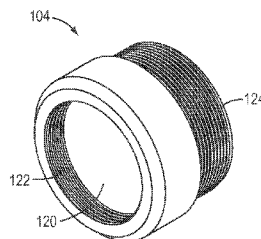

FIG. 3A

(57) Abstract: The invention includes a connector (100) for coupling to a composite pipe, and methods for forming the same. The connector has a seal carrier (102) forming a fluid passage that is made of a first material and that includes a seal receiving portion (108) configured to receive at least one seal and a first coupling surface on an outer seal carrier surface. The connector also has an interconnect (104) with a passage configured to receive the seal carrier (102) that is made of a second material and includes a second coupling surface on an inner interconnect surface configured for coupling with the first coupling surface to connect the seal carrier (102) and the interconnect (104) and a third coupling surface on an outer interconnect surface.



WO 2014/026190 A1

## COMPOSITE COILED TUBING CONNECTORS

### CROSS-REFERENCE TO RELATED APPLICATION

5 [0001] The current application claims priority to U.S. Provisional Application Serial Number 61/681,895, filed August 10, 2012.

### FIELD OF THE INVENTION

10 [0002] This application relates generally to connectors for use with a spoolable pipe constructed of composite material and more particularly to a connector formed of a plurality of parts.

### BACKGROUND

15 [0003] A spoolable pipe in common use is steel coiled tubing which finds a number of uses in oil well operations. For example, it is used in running wireline cable down hole with well tools, such as logging tools and perforating tools. Such tubing is also used in the workover of wells, to deliver various chemicals downhole and perform other functions. Coiled tubing offers a much faster and less expensive way to run pipe into a wellbore in that it eliminates the time consuming task of joining typical 30 foot pipe sections by threaded connections to make up a pipe string that typically will be up to 10,000 feet or longer.

20 [0004] Steel coiled tubing is capable of being spooled because the steel used in the product exhibits high ductility (i.e. the ability to plastically deform without failure). The spooling operation is commonly conducted while the tube is under high internal pressure which introduces combined load effects. Unfortunately, repeated spooling and use can cause fatigue damage and the steel coiled tubing can suddenly fracture and fail. The hazards of operation, and the risk to personnel and the high economic cost of failure resulting in down time to conduct fishing operations, typically forces the product to be retired before any expected failure after a relatively few number of trips into a well. The cross section of steel tubing may expand during repeated use, resulting in reduced wall thickness and higher bending strains with associated reduction in the pressure carrying capability. Steel coiled tubing presently in service is generally limited to internal pressures of about 5000 psi. Higher internal pressure

25  
30

- 2 -

significantly reduces the integrity of coiled tubing so that it will not sustain continuous flexing and thus severely limits its service life.

[0005] It is therefore desirable to provide a substantially non-ferrous spoolable pipe capable of being deployed and spooled under borehole conditions and which does not suffer from the structural limitations of steel tubing, and which is also highly resistant to chemicals. Such non-ferrous spoolable pipe often carries fluids which may be transported from the surface to a downhole location, as in the use of coiled tubing, to provide means for treating formations or for operating a mud motor to drill through the formations. In addition, it may be desirable to transport devices through the spoolable pipe, such as through a coiled tubing bore to a downhole location for various operations. Therefore, an open bore within the spoolable pipe is essential for some operations.

[0006] In the case of coiled tubing, external pressures can also be a major load condition and can be in excess of 2500 psi. Internal pressure may range from 5,000 psi to 10,000 psi in order to perform certain well operations; for example, chemical treatment or fracturing. Tension and compression forces on coiled tubing are severe in that the tubing may be forced into or pulled from a borehole against frictional forces in excess of 20,000 lbf.

[0007] For the most part, prior art non-metallic tubular structures that are designed for being spooled and also for transporting fluids, are made as a hose, whether or not they are called a hose. An example of such a hose is the Feucht structure in U.S. Pat. No. 3,856,052, which has longitudinal reinforcement in the side walls to permit a flexible hose to collapse preferentially in one plane. However, the structure is a classic hose with vulcanized polyester cord plies which are not capable of carrying compression loads or high external pressure loads. Hoses typically use an elastomer such as rubber to hold fiber together, but do not use a high modulus plastic binder such as epoxy. Hoses are generally designed to bend and carry internal pressure, but are not normally subjected to external pressure or high axial compression or tension loads. For an elastomeric type material, such as that often used in hoses, the elongation at break is so high (typically greater than 400 percent) and the stress-strain response so highly nonlinear, it is common practice to define a modulus corresponding to a specified elongation. The modulus for an elastomeric material corresponding to 200 percent elongation typically ranges from 300 psi to 2000 psi. The modulus of elasticity for plastic matrix material typically used in a composite tube tends to range from about 100,000 psi to about 500,000 psi or greater, with representative strains to failure of from about 2 percent to about 10 percent. This large

- 3 -

difference in modulus and strain to failure between rubber and plastics, and thus between hoses and composite tubes, is part of what permits a hose to be easily collapsed to an essentially flat condition under relatively low external pressure and eliminates the capability of the hose to carry high axial tension or compression loads, while the higher modulus characteristic of the plastic matrix material used in a composite tube tends to be sufficiently stiff to transfer loads into the fibers and thus resist high external pressure, axial tension, and compression without collapse. Constructing a composite tube to resist high external pressure and compressive loads may include the use of complex composite mechanics engineering principles to ensure that the tube has sufficient strength. It has not been previously considered feasible to build a truly composite tube capable of being bent to a relatively small diameter, and be capable of carrying internal pressure and high tension and compression loads in combination with high external pressure requirements. Specifically, a hose is not expected to sustain high compression and external pressure loads.

**[0008]** In operations involving spoolable pipe, it is often necessary to make various connections, such as to interconnect long sections or to connect tools or other devices into or at the end of the pipe string. With steel coiled tubing, a variety of well-known connecting techniques are available to handle the severe loads encountered in such operations. Threaded connections as well as welded connections are often applied and meet the load requirements described.

**[0009]** Grapple and slip type connectors have also been developed for steel coiled tubing to provide a low profile while being field serviceable. However, these steel tubing connectors tend not to be applicable to modern composite coiled tubing. One such connector is shown in U.S. Pat. No. 4,936,618 to Sampa et al., showing a pair of wedge rings for making a gripping contact with the coiled tubing. The PETRO-TECH Tools Incorporated catalog shows coiled tubing E-Z Connectors, Product Nos. 9209 to 9211 that are also examples of a slip type steel coiled tubing connector.

**[0010]** Another connector for reeled thin-walled tubing is shown in U.S. Pat. No. 5,156,206 to Cox, and uses locking slips for engaging the tubing in an arrangement similar to the Petro-Tech connector. U.S. Pat. No. 5,184,682 to Delacour et al. shows a connector having a compression ring for engaging a rod for use in well operations, again using a technique similar to a Petro-Tech connector to seal against the rod.

- 4 -

[0011] These commercial coiled tubing connectors would not be expected to seal properly to a composite pipe, partially because of circumferential deformation of the pipe inwardly when the connector is on the composite pipe, and also because the external surface of a composite tube or pipe tends not to be as regular in outer diameter tolerance as a steel hose.

5 [0012] U.S. Pat. No. 4,530,379 to Policelli teaches a composite fiber tubing with a structural transition from the fiber to a metallic connector. The fibers may be graphite, carbon, aramid or glass. The FIG. 4 embodiment can be employed in a fluid conveyance pipe having bending loads in addition to internal pressure loads, and in structural members having bending and axial stiffness requirements.

10 [0013] While many connectors designed for application to elastomeric hoses and tubes, such as shown in U.S. Pat. No. 3,685,860 to Schmidt, and U.S. Pat. No. 3,907,335 to Burge et al., sealing to these hoses is substantially different in that the hose body itself serves as a sealing material when pressed against the connecting members. A composite pipe would be considered too rigid to function in this way. U.S. Pat. No. 4,032,177 to Anderson shows an end  
15 fitting for a non-metallic tube such as a plastic tube and having a compression sleeve and a tubing reinforcing insert, but again appears to rely on the tube being deformable to the extent of effecting a seal when compressed by the coupling.

[0014] Another coupling for non-metallic natural gas pipe is shown in U.S. Pat. No. 4,712,813 to Passerell et al., and appears to show a gripping collet for engaging the outer  
20 tubular surface of the pipe and a sealing arrangement for holding internal gas pressure within the pipe, but no inner seals are on the pipe and seals cannot be changed without disturbing the gripping mechanism.

[0015] U.S. Pat. No. 5,351,752 to Wood et al. appears to show a bonded connector for  
25 coupling composite tubing sections for pumping a well. The composite tubing has threaded fittings made of composite materials which are bonded to the tubing.

[0016] Often, connectors (e.g., interconnects, flanges, and other components for connecting  
30 the end of tubing to other elements) are formed from a single piece of bar stock. Because of the dimensional differences between different sections (e.g., a narrower section to fit in the tubing and a thicker section to extend beyond the tubing), the bar stock must be machined down from the thickest dimension, often resulting in a sizable loss of material. Additionally, forming the connector from a single piece of bar stock limits the connector to a single material. This may

- 5 -

further increase material costs when a more expensive material is required for only certain portions of the connector but is used for the entire connector.

#### SUMMARY

[0017] In view of the foregoing, there is a need for a connector that minimizes the loss of material through processing and allows for the use of different materials in a single connector.

5 [0018] The present invention includes connectors (and methods for forming the same) having multiple parts. The individual components may be formed and/or machined from materials relatively similarly dimensioned to the final product to lessen the loss of material. Additionally, creating components from different pieces of stock material enables the use of different kinds of material in the final connector.

10 [0019] In one aspect, the invention includes a connector for coupling to a composite pipe. The connector has a seal carrier forming a fluid passage that is made of a first material and that includes a seal receiving portion configured to receive at least one seal and a first coupling surface on an outer seal carrier surface. The connector also has an interconnect with a passage configured to receive the seal carrier that is made of a second material and includes a second  
15 coupling surface on an inner interconnect surface configured for coupling with the first coupling surface to connect the seal carrier and the interconnect and a third coupling surface on an outer interconnect surface.

[0020] In one embodiment, the first material is stainless steel (e.g., ASTM A316/316L Stainless Steel). In another embodiment, the seal receiving portion has at least one groove. In  
20 some embodiments the first coupling surface is a threaded surface, while in other embodiments the first coupling surface is a smooth surface. The second material may be different from the first material, and the second material may be carbon steel (e.g., ASTM A106 Carbon Steel). The second coupling surface may be a threaded surface in certain embodiments, and may be a smooth surface in other embodiments. The third coupling surface may be a threaded surface.  
25 In certain embodiments, a maximum outer diameter of the seal carrier is substantially equal to or less than a minimum inner diameter of the interconnect.

[0021] Another aspect of the invention includes a method of forming a connector for a composite pipe. The method includes providing a first stock material and processing the first stock material to form a seal carrier (e.g., a mandrel). The seal carrier includes a seal receiving  
30 portion configured to receive at least one seal and a first coupling surface on an outer seal carrier surface. The method also includes providing a second stock material and processing the

second stock material to form an interconnect. The interconnect includes a second coupling surface on an inner interconnect surface configured for coupling with the first coupling surface to connect the seal carrier and the interconnect and a third coupling surface on an outer interconnect surface.

5 [0022] In one embodiment, the first stock material comprises bar stock, which may be machined to a lesser diameter. In some embodiments, the second stock material comprises bar stock that may be machined to a lesser diameter. A maximum diameter of the first stock material may be less than a maximum diameter of the second stock material. In another embodiment, a maximum outer diameter of the seal carrier is  
10 substantially equal to or less than a minimum inner diameter of the interconnect.

[0023] Yet another aspect of the invention includes a flange for coupling to a composite pipe. The flange has an insert with a fluid passage and a first coupling surface, and is made of a first material. The flange also has an interconnect with a second coupling surface configured for coupling with the first coupling surface to connect the insert and  
15 the interconnect and a third coupling surface, and is made from a second material.

[0024] In certain embodiments the first and/or the second material are stainless steel, carbon steel, corrosion resistant alloys, composites, coated materials, or combinations thereof. The first and second materials may be different materials, or they may be the same material. The insert may further include a lip. In some embodiments, the third  
20 coupling surface is substantially perpendicular to the second coupling surface. The third coupling surface may have a plurality of openings, which may be disposed in a standard bolt pattern. At least one of the insert and the interconnect may be machined from bar stock, and the insert and the interconnect may be configured to be press fit together.

[0025] These and other objects, along with advantages and features of the present  
25 invention, will become apparent through reference to the following description, the accompanying drawings, and the claims. Furthermore, it is to be understood that the features of the various embodiments described herein are not mutually exclusive and may exist in various combinations and permutations.

[0025a] In one aspect of the invention, there is provided a connector for coupling to a  
30 composite pipe, the connector including: a seal carrier defining a fluid passage, the seal carrier including: a first end and a second end; a seal receiving portion extending from the first end and including a cylindrical outer surface with a uniform diameter and a plurality



of spaced-apart grooves formed in the outer surface, each groove configured to receive an annular seal, the seal receiving portion configured to be disposed within the composite pipe and the annular seals configured to seal between the composite pipe and the seal carrier; and a coupling portion extending from the second end to the seal receiving  
5 portion, the coupling portion including a threaded segment along a first cylindrical coupling surface of an outer seal carrier surface; and an interconnect defining a passage configured to receive the seal carrier, the interconnect including: a second cylindrical coupling surface on an inner interconnect surface including a threaded segment configured for coupling with the threaded segment of the first cylindrical coupling surface  
10 to connect the seal carrier and the interconnect; a third coupling surface on a cylindrical outer interconnect surface, wherein a maximum outer diameter of the seal carrier is equal to or less than a minimum inner diameter of the interconnect, exclusive of the first cylindrical coupling surface and the second cylindrical coupling surface; and wherein the first and the second ends of the seal carrier are positioned outside of the interconnect  
15 when the threaded segments of the first cylindrical coupling surface and the second cylindrical coupling surface are threaded together.

#### BRIEF DESCRIPTION OF THE DRAWINGS

[0026] In the drawings, like reference characters generally refer to the same parts  
20 throughout the different views. Also, the drawings are not necessarily to scale, emphasis instead generally being placed upon illustrating the principles of the invention. In the

- 7 -

following description, various embodiments of the present invention are described with reference to the following drawings, in which:

- [0027] FIG. 1A is a schematic perspective view of a service end connector, in accordance with one embodiment of the invention;
- 5 [0028] FIG. 1B is a schematic, transparent side view of the service end connector depicted in FIG. 1A;
- [0029] FIG. 1C is a schematic cross-section view of the service end connector taken along the line C-C in FIG. 1B;
- [0030] FIG. 2A is a schematic perspective view of a seal carrier of the service end  
10 connector depicted in FIG. 1A;
- [0031] FIG. 2B is a schematic transparent side view of the seal carrier depicted in FIG. 2A;
- [0032] FIG. 2C is a schematic cross-section view of the seal carrier taken along the line C-C in FIG. 2B;
- [0033] FIG. 3A is a schematic perspective view of an interconnect of the service end  
15 connector depicted in FIG. 1A;
- [0034] FIG. 3B is a schematic, transparent side view of the interconnect depicted in FIG. 3A;
- [0035] FIG. 3C is a schematic cross-section view of the interconnect taken along the line C-C in FIG. 3B;
- 20 [0036] FIG. 4A is a schematic perspective view of a pipe-to-pipe connector, in accordance with another embodiment of the invention;
- [0037] FIG. 4B is a schematic, transparent side view of the pipe-to-pipe connector depicted in FIG. 4A;
- [0038] FIG. 4C is a schematic cross-section view of the pipe-to-pipe connector taken along  
25 the line C-C in FIG. 4B;
- [0039] FIG. 5A is a schematic perspective view of a seal carrier of the pipe-to-pipe connector depicted in FIG. 4A;
- [0040] FIG. 5B is a schematic, transparent side view of the seal carrier depicted in FIG. 5A;
- [0041] FIG. 5C is a schematic cross-section view of the seal carrier taken along the line C-  
30 C in FIG. 5B;
- [0042] FIG. 6A is a schematic perspective view of an interconnect of the pipe-to-pipe connector depicted in FIG. 4A;

- 8 -

- [0043] FIG. 6B is a schematic, transparent side view of the interconnect depicted in FIG. 6A;
- [0044] FIG. 6C is a schematic cross-section view of the interconnect taken along the line C-C in FIG. 6B;
- 5 [0045] FIG. 7 is a schematic, exploded perspective view of a flange, in accordance with another embodiment of the invention;
- [0046] FIG. 8A is a schematic perspective view of an insert of the flange depicted in FIG. 7;
- [0047] FIG. 8B is a schematic side view of the insert depicted in FIG. 8A;
- 10 [0048] FIG. 8C is a schematic cross-section view of the insert taken along the line A-A in FIG. 8B;
- [0049] FIG. 9A is a schematic perspective view of an interconnect of the flange depicted in FIG. 7;
- [0050] FIG. 9B is a schematic front view of the interconnect depicted in FIG. 9A; and
- 15 [0051] FIG. 9C is a schematic cross-section view of the interconnect taken along the line A-A in FIG. 9B.

#### DETAILED DESCRIPTION OF THE INVENTION

[0052] While this invention is directed generally to providing connectors for composite spoolable pipe, the disclosure is directed to a specific application involving line pipe, coiled tubing service and downhole uses of coiled tubing. Composite coiled tubing offers the potential

20 to exceed the performance limitations of isotropic metals, thereby increasing the service life of the pipe and extending operational parameters. Composite coiled tubing is constructed as a continuous tube fabricated generally from non-metallic materials to provide high body strength and wear resistance. This tubing can be tailored to exhibit unique characteristics which optimally address burst and collapse pressures, pull and compression loads, and high strains

25 imposed by bending. This enabling capability expands the performance parameters beyond the physical limitations of steel or alternative isotropic material tubulars. In addition, the fibers and resins used in composite coiled tubing construction help make the tube impervious to corrosion and resistant to chemicals used in treatment of oil and gas wells.

[0053] High performance composite structures are generally constructed as a buildup of

30 laminant layers with the fibers in each layer oriented in a particular direction or directions. These fibers are normally locked into a preferred orientation by a surrounding matrix material.

The matrix material, normally much weaker than the fibers, serves the critical role of transferring load into the fibers. Fibers having a high potential for application in constructing composite pipe include glass, carbon, and aramid. Epoxy or thermoplastic resins are good candidates for the matrix material.

5 [0054] The connector of the present invention can have application to any number of composite tube designs, including configured to be applied to a pipe having an outer surface made from a composite material that can receive gripping elements which can penetrate into the composite material without destroying the structural integrity of the outer surface. This outer surface can act as a wear surface as the pipe engages the surface  
10 equipment utilized in handling such pipe. The composite pipe is suitable for use in wellbores or as line pipe. Several connectors for similar uses are described in U.S. Patent Publication No. 20090278348. Some of the components, such as slip nuts, may be used interchangeably with the connectors described below.

[0055] FIGS. 1A-1C depict a service end connector 100 for attaching a composite  
15 pipe to a service member, such as a logging tool, t-fitting, or flange. The end connector 100 may be assembled from two components, e.g., a seal carrier 102 and an interconnect 104. The interconnect 104 may be sized to fit over the seal carrier 102. The interconnect 104 and the seal carrier 102 may be connected to each other via a number of techniques, including a threaded connection and/or a press fit.

20 [0056] FIGS. 2A-2C depict the seal carrier 102. The seal carrier 102 may define a fluid passage 106 running the length of the seal carrier 102, thereby allowing a fluid to pass freely therethrough. A seal receiving portion 108 may be located on an outer surface of the seal carrier 102, e.g., at an end of the seal carrier 102, to receive seals for providing a fluid tight connection with a composite pipe. Grooves 110 may be formed in the seal  
25 receiving portion 108 to limit movement of the seals. The seal carrier 102 may also have a first coupling surface 112 on an outer surface thereof. The first coupling surface 112 may form an outer diameter indicated in FIG. 2C as OD<sub>1</sub>, that may represent a maximum outer diameter of the seal carrier 102 (particularly when the first coupling surface 112 is a smooth surface). In embodiments where the first coupling surface 112 is a threaded  
30 surface, the ends of the threads may extend nominally beyond the diameter OD<sub>1</sub>, instead having a maximum diameter as indicated by OD<sub>2</sub>.

- 10 -

The maximum outer diameter is the minimum size of stock material that may be used in forming the seal carrier 102. In various embodiments, the maximum outer diameter of the seal carrier 102 may be about one inch to about twelve inches, although dimensions above and below this range are also contemplated. The seal carrier 102 may be about six inches to about thirty-six inches in length, although embodiments of less than six inches in length and greater than thirty-six inches in length are contemplated. The seal carrier 102 may be made of any of a variety of materials, including carbon steel, stainless steel, corrosion resistant alloys, and/or composites.

[0057] FIGS. 3A-3C depict the interconnect 104 for use with the seal carrier 102. A passage 120 may extend through the interconnect 104, allowing for movement of the interconnect 104 over the seal carrier 102. The passage 120 may define an inner diameter of the interconnect 104, as indicated by 'ID' in FIG. 3C. The inner diameter ID may be substantially equal to or greater than the outer diameter  $OD_1$  or  $OD_2$ . Any overlap between the dimensions due to thread height are likely to be minimal and the inner diameter ID would still be considered to be substantially equal to or greater than the outer diameter  $OD_2$ . The interconnect 104 may have a second coupling surface 122 on an inner surface thereof for coupling with the first coupling surface 112. The second coupling surface 122 may be complementary with the first coupling surface 112, e.g., both are threaded (as depicted) or both are smooth (for a press fit). An outer surface of the interconnect 104 may have a third coupling surface 124 for attachment to other components, e.g., a slip nut for securing the pipe or downhole tools. In various embodiments, the interconnect 104 may be about one inch to about twelve inches in length, and may be shorter than one inch or longer than twelve inches. The interconnect 104 may be made of a variety of materials, including carbon steel, stainless steel, corrosion resistant alloys, and/or composites. As the seal carrier 102 and the interconnect 104 are separate components, they may easily be made of different materials. Use of high cost materials may be limited to the component where they are needed, thereby saving in material costs. Material and machining costs may also be reduced over unitary constructions by starting the formation process with stock materials closer in size to the finished components. For example, the service end connector 102 may be formed by providing a first stock material (e.g., bar stock) with dimensions approximately similar to the final dimensions of the seal carrier 102. The stock material may be machined to add the features of the seal carrier 102, e.g., the receiving portion 108 and the first coupling surface 112, by reducing the outer diameter of

- 11 -

certain portions. Depending on the material used, the seal carrier 102 may be otherwise formed, e.g., by molding. A second stock material (e.g., bar stock) may be provided with dimensions approximately similar to the final dimensions of the interconnect 104, then machined to add the required features, e.g., the second coupling surface 122 and the third  
5 coupling surface 124, by reducing the outer diameter of the second bar stock (and increasing the inner diameter) in selected areas. As the seal carrier 102 generally has a lesser outer diameter than the interconnect 104, the first stock material may have a lesser maximum diameter than a maximum diameter of the second stock material. Once the seal carrier 102 and the interconnect 104 are formed, they may be combined by many known methods, including  
10 the threaded connection depicted in FIGS. 1A-C.

**[0058]** In other embodiments, processes other than those described above may be used to make the seal carrier 102 and the interconnect 104. For example, the seal carrier 102 and the interconnect 104 may be made by casting, forging, molding, extruding, and other known fabrication methods. The seal carrier 102 and the interconnect 104 may be made with the same  
15 process, or may be made with different processes. The seal carrier 102 and the interconnect 104 may each be made through multiple known processes.

**[0059]** FIGS. 4A-4C depict a pipe-to-pipe connector 400 that is substantially similar to the service end connector 100, but instead of connecting a pipe to a different device the connector 400 connects pipes to each other. This may result in a substantially symmetrical appearance of  
20 the connector 400 as seen in the figures.

**[0060]** A seal carrier 402, as seen in FIGS. 5A-5C, is similar to the seal carrier 102, though seal receiving portions 408 are disposed on opposite ends of the seal carrier 402 with a smooth first coupling surface 412 inbetween. The seal carrier 402 may have a fluid passage 406 and an outer diameter designated 'OD', along with grooves 410 in the seal receiving portions 408. An  
25 interconnect 404 depicted in FIGS. 6A-6C is similar to the interconnect 104, but the interconnect 404 has a smooth second coupling surface 422 and threaded third coupling surfaces 424 at opposite ends. The interconnect 404 defines a passage 420 with an inner diameter designated 'ID'. The inner diameter ID and the outer diameter OD are substantially similar so that the seal carrier 402 may be press fit into the interconnect 404. A protrusion or

- 12 -

stop may be provided on the first coupling surface 412 and adapted for contact with a corresponding relief in the passage 420 the help provide accurate positioning.

**[0061]** FIG. 7 depicts a flange 700 with an insert 702 and an interconnect 704. The insert 702, as described in more detail below, is configured for insertion into other object (e.g., the interconnect 704), while the interconnect 704 is configured for attachment to a different component. The insert 702 and the interconnect 704 are depicted in FIG. 7 in a disconnected state, however in use they will be connected such that the flange 700 may appear to be of unitary construction.

**[0062]** The insert 702 depicted in FIGS. 8A-8C may be substantially cylindrical, with several features similar to the seal carriers 102, 402, such as a fluid passage 706 running the length of the insert 702, thereby providing an open path for the transfer of fluids, tools, and other objects and substances. A first insert coupling surface 712 having an outer diameter of dimension  $OD_{F1}$  is configured for mating with the interconnect 704. A lip 730 having an outer diameter of dimension  $OD_{F2}$  may be provided on an end of the insert 702 as a mechanical stop when inserted into the interconnect 704. As the outer diameter  $OD_{F2}$  of the lip 730 may be the largest diametrical dimension on the insert, bar stock of at least this size may be required.

**[0063]** The interconnect 704 depicted in FIGS. 9A-9C may also be substantially cylindrical and is configured for mating with other components. A middle portion of the interconnect 704 may be substantially open, forming a passage 720 to complement the passage 706 in providing a path for transportation through the flange 700. A second interconnect coupling surface 722 with an inner diameter  $ID_F$  may be formed on the interior of the interconnect 704 and be sized to receive and mate with the first insert coupling surface 712. For example, the inner diameter  $ID_F$  of the complementary second interconnect coupling surface 722 may be substantially the same as, or slightly greater than, the outer diameter  $OD_{F1}$  of the first insert coupling surface 712. Several openings 726 may be provided on a third coupling surface 724 having an outer diameter  $OD_{F3}$  of the interconnect 704 to facilitate attachment to other components, particularly those with a complementary bolt pattern. The openings 726 may be located in various standard or non-standard bolt patterns to enable attachment to various components.

**[0064]** As with the previously described embodiments, the insert 702 and the interconnect 704 may be made using a variety of methods and materials, and may come in a variety of sizes.

- 13 -

For example, the insert 702 may be machined from a corrosion resistant material, such as stainless steel (e.g., 316L stainless steel), while the interconnect 704 is machined from a less corrosion resistant material, such as carbon steel (e.g., A105 carbon steel). Other formation methods and materials as described above may also be used. The insert 702 may range in size  
5 from as little as one inch to as much as twelve inches in diameter, and as short as a half inch to as much as twelve inches in length, although dimensions both below and above these ranges are possible. The interconnect 704 may range in size from as little as two inches to as much as eighteen inches in diameter, and as short as a quarter inch to as much as six inches in length, though again dimensions both below and above these ranges are possible.

10 **[0065]** For each of the service end connector 100, the pipe-to-pipe connector 400, and the flange 700, the narrower end is inserted into the end of a pipe (either with or without seals). In some circumstances this fit may be tight enough to be secure without additional support, while often another device (e.g., a clamp or nut) is provided for a secure fit. Each of the service end connector 100, the pipe-to-pipe connector 400, and the flange 700 may also be connected with  
15 another component (either before or after attachment to a pipe). The service end connector 100, the pipe-to-pipe connector 400, and the flange 700 each provide a pathway for production of fluid, transportation of tools, or other purpose considered desirable while the components are engaged.

#### Equivalents

20 **[0066]** Unless otherwise specified, the illustrated embodiments can be understood as providing exemplary features of varying detail of certain embodiments, and therefore, unless otherwise specified, features, components, modules, and/or aspects of the illustrations can be otherwise combined, separated, interchanged, and/or rearranged without departing from the disclosed systems or methods. Additionally, the shapes and sizes of components are also  
25 exemplary and unless otherwise specified, can be altered without affecting the scope of the disclosed and exemplary systems or methods of the present disclosure.

**[0067]** While specific embodiments of the subject invention have been discussed, the above specification is illustrative and not restrictive. Many variations of the invention will become apparent to those skilled in the art upon review of this specification. The full scope of the  
30 invention should be determined by reference to the claims, along with their full scope of equivalents, and the specification, along with such variations.



- 14 -

[0068] Unless otherwise indicated, all numbers expressing quantities of ingredients, reaction conditions, and so forth used in the specification and claims are to be understood as being modified in all instances by the term “about.” Accordingly, unless indicated to the contrary, the numerical parameters set forth in this specification and attached claims are approximations that may vary depending upon the desired properties sought to be obtained by the present invention.

[0069] The terms “a” and “an” and “the” used in the context of describing the invention (especially in the context of the following claims) are to be construed to cover both the singular and the plural, unless otherwise indicated herein or clearly contradicted by context. Recitation of ranges of values herein is merely intended to serve as a shorthand method of referring individually to each separate value falling within the range. Unless otherwise indicated herein, each individual value is incorporated into the specification as if it were individually recited herein. All methods described herein can be performed in any suitable order unless otherwise indicated herein or otherwise clearly contradicted by context. The use of any and all examples, or exemplary language (*e.g.* “such as”) provided herein is intended merely to better illuminate the invention and does not pose a limitation on the scope of the invention otherwise claimed. No language in the specification should be construed as indicating any non-claimed element essential to the practice of the invention.

[0070] Having described certain embodiments of the invention, it will be apparent to those of ordinary skill in the art that other embodiments incorporating the concepts disclosed herein may be used without departing from the spirit and scope of the invention. Accordingly, the described embodiments are to be considered in all respects as only illustrative and not restrictive.

[0071] What is claimed is:

25

CLAIMS

1. A connector for coupling to a composite pipe, the connector comprising:
  - a seal carrier defining a fluid passage, the seal carrier comprising:
    - a first end and a second end;
    - a seal receiving portion extending from the first end and comprising a cylindrical outer surface with a uniform diameter and a plurality of spaced-apart grooves formed in the outer surface, each groove configured to receive an annular seal, the seal receiving portion configured to be disposed within the composite pipe and the annular seals configured to seal between the composite pipe and the seal carrier; and
    - a coupling portion extending from the second end to the seal receiving portion, the coupling portion comprising a threaded segment along a first cylindrical coupling surface of an outer seal carrier surface; and
    - an interconnect defining a passage configured to receive the seal carrier, the interconnect comprising:
      - a second cylindrical coupling surface on an inner interconnect surface comprising a threaded segment configured for coupling with the threaded segment of the first cylindrical coupling surface to connect the seal carrier and the interconnect;
      - a third coupling surface on a cylindrical outer interconnect surface, wherein a maximum outer diameter of the seal carrier is equal to or less than a minimum inner diameter of the interconnect, exclusive of the first cylindrical coupling surface and the second cylindrical coupling surface; and
      - wherein the first and the second ends of the seal carrier are positioned outside of the interconnect when the threaded segments of the first cylindrical coupling surface and the second cylindrical coupling surface are threaded together.
2. The connector of claim 1, wherein the seal carrier comprises a first material and the interconnect comprises a second material, wherein the second material is different from the first material.

3. The connector of claim 1, wherein the cylindrical outer interconnect surface of the interconnect comprises a recessed segment, and wherein the recessed segment comprises the third coupling surface.

4. The connector of claim 1, wherein the interconnect comprises a first end and a second end, and wherein the second cylindrical coupling surface extends to the first end and the third coupling surface extends to the second end.

5. The connector of claim 4, wherein the interconnect further comprises a portion between the first and second ends having an outer diameter that is greater than an outer diameter of the third coupling surface.

6. The connector of claim 2, wherein the first material comprises a material selected from the group consisting of stainless steel, carbon steel, corrosion resistant alloys, composites, coated materials, and combinations thereof.

7. The connector of claim 2, wherein the first material is stainless steel and the second material is carbon steel.

8. The connector of claim 1, wherein the third coupling surface comprises a threaded surface.

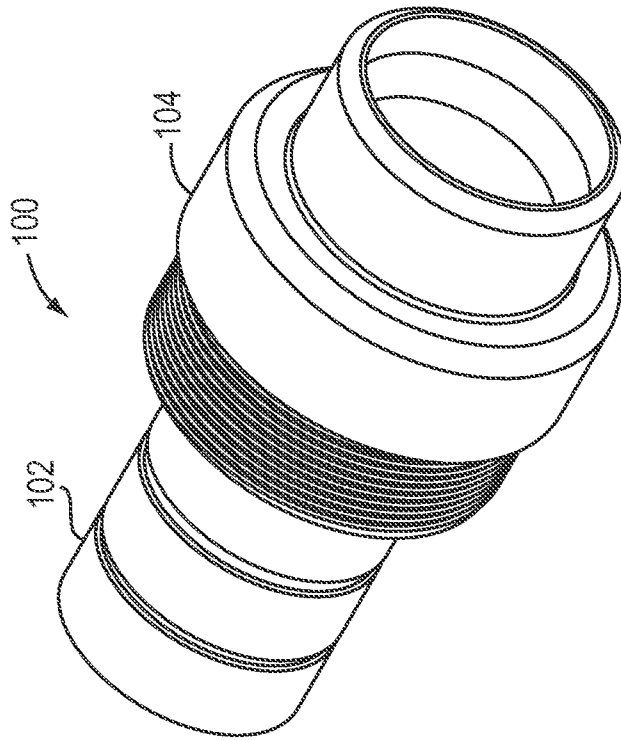

FIG. 1A

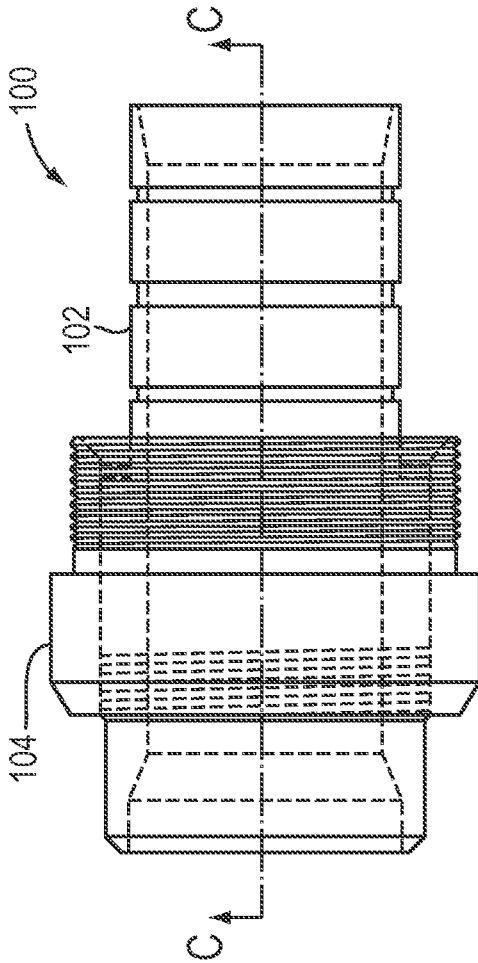

FIG. 1B

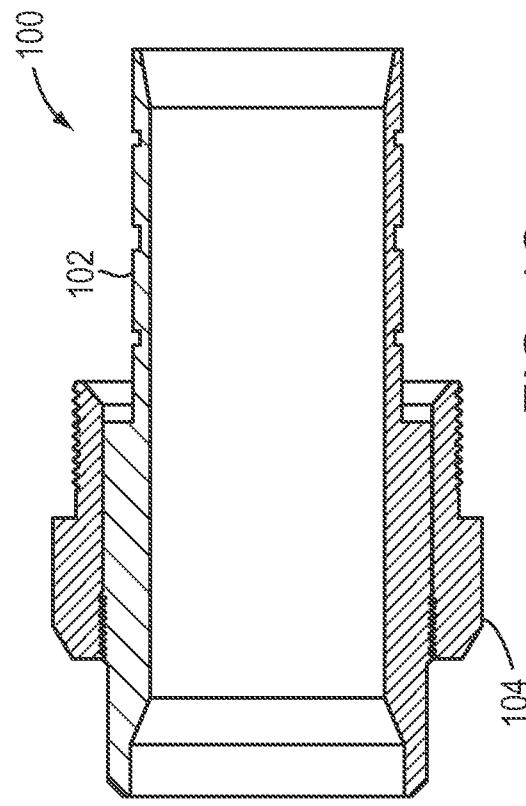

FIG. 1C

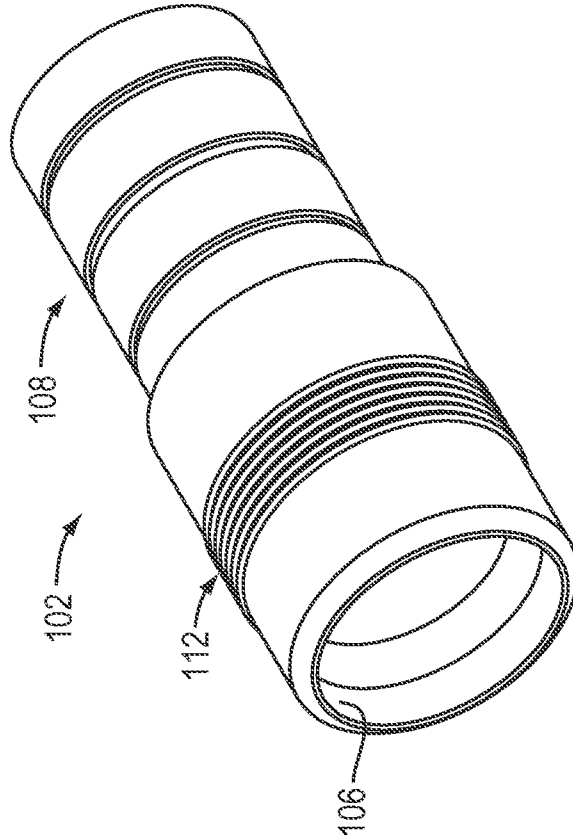

FIG. 2A

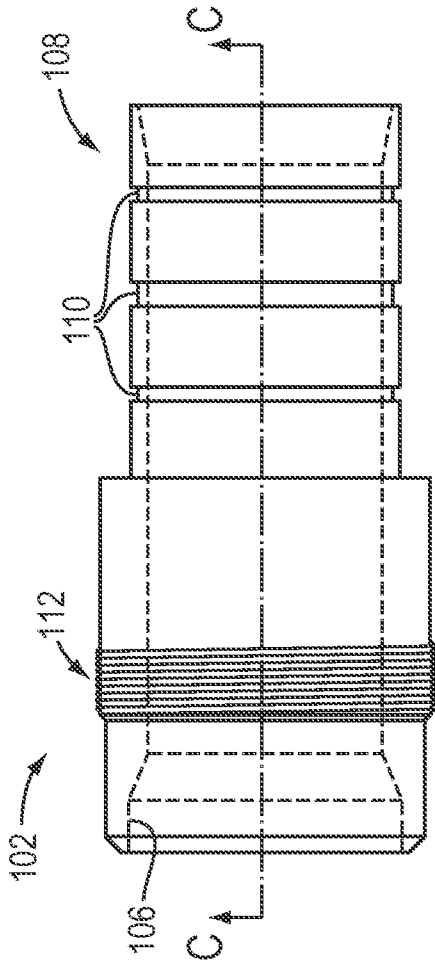

FIG. 2B

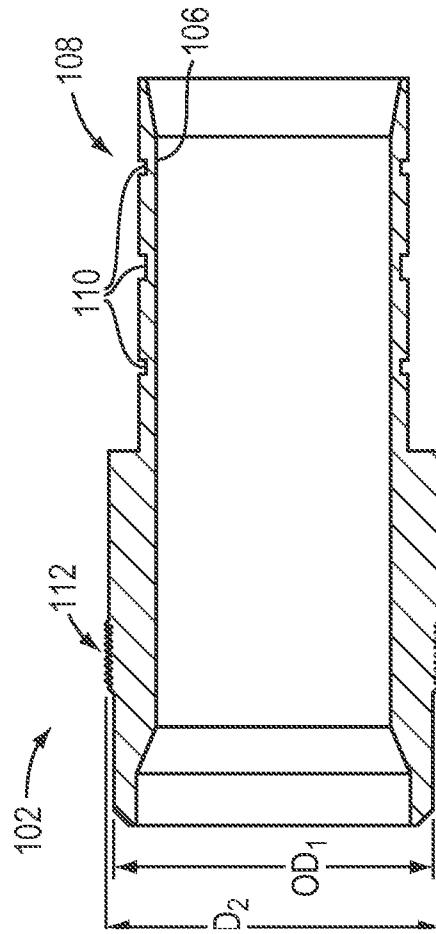

FIG. 2C

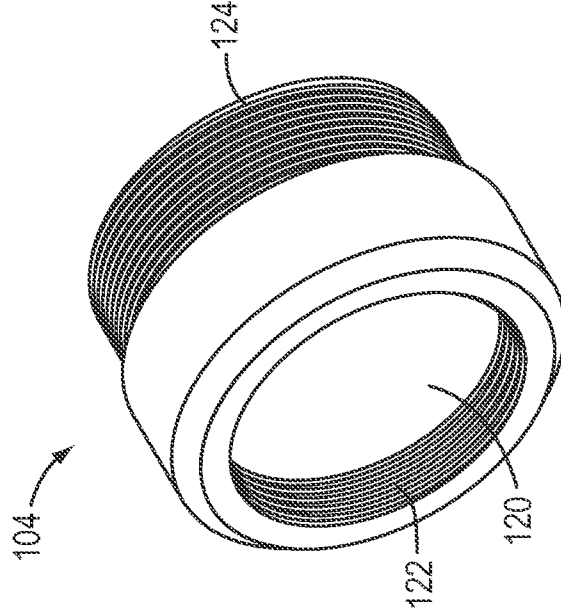

FIG. 3A

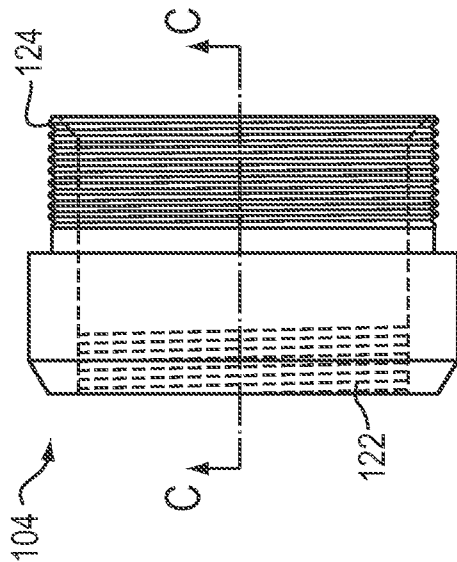

FIG. 3B

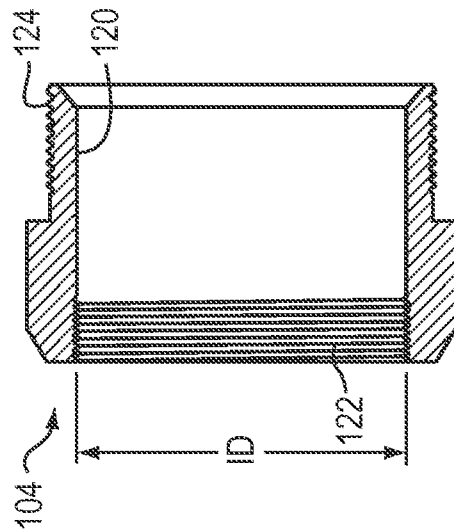

FIG. 3C

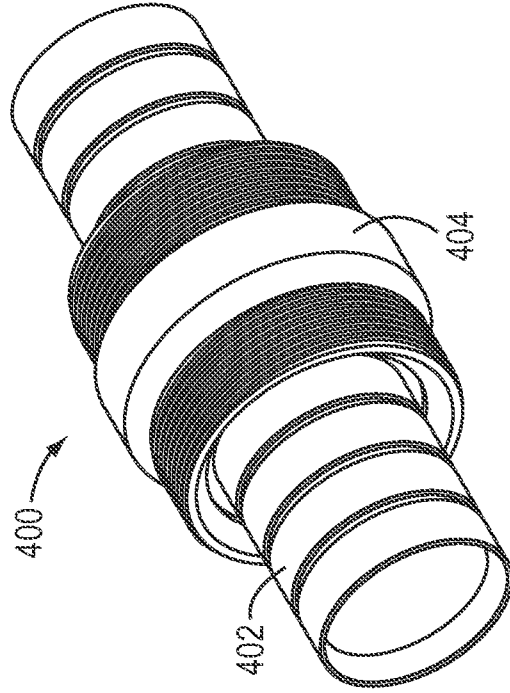

FIG. 4A

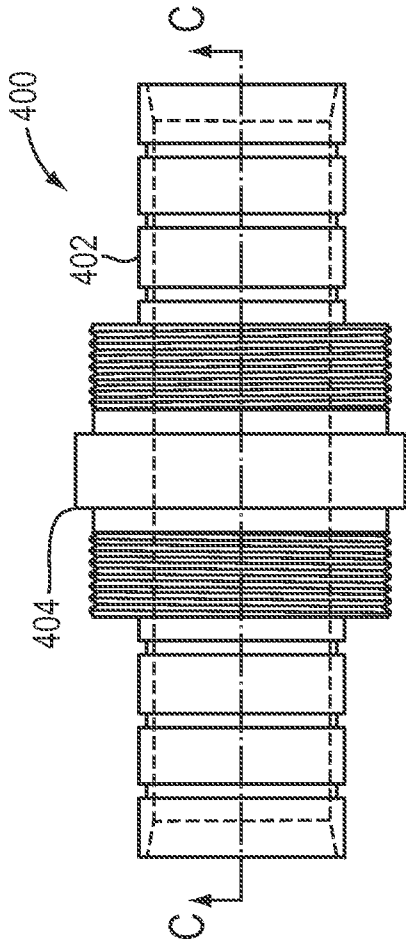

FIG. 4B

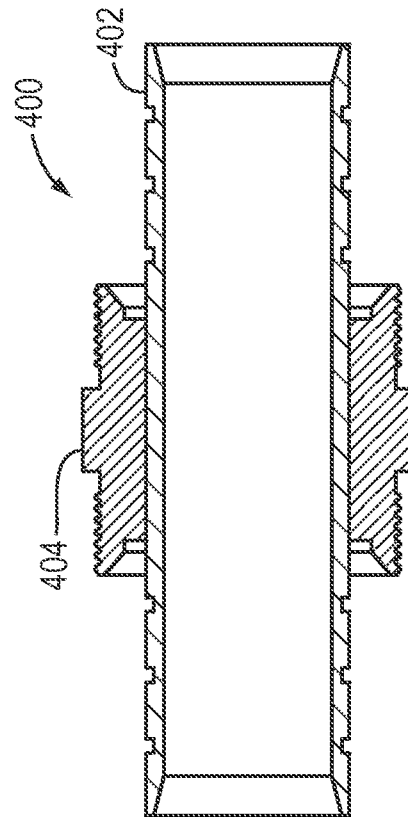

FIG. 4C

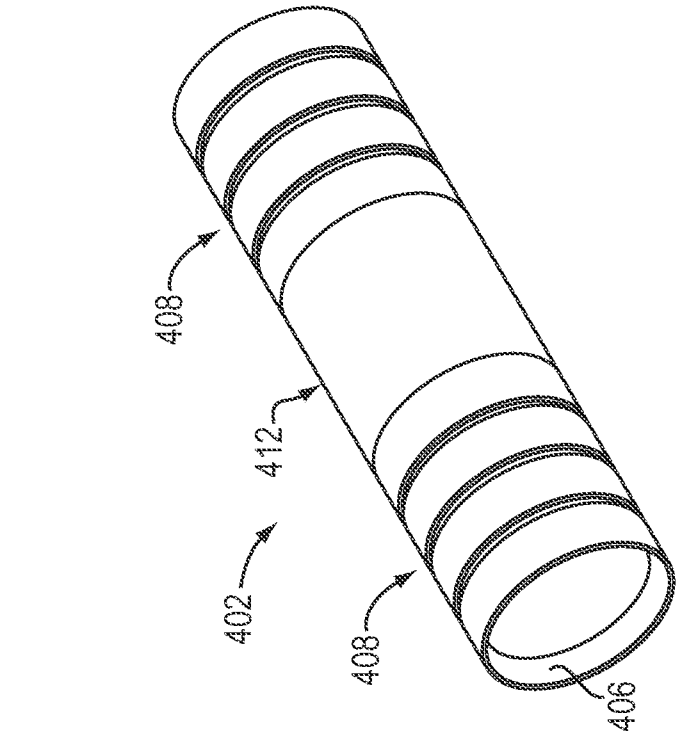

FIG. 5A

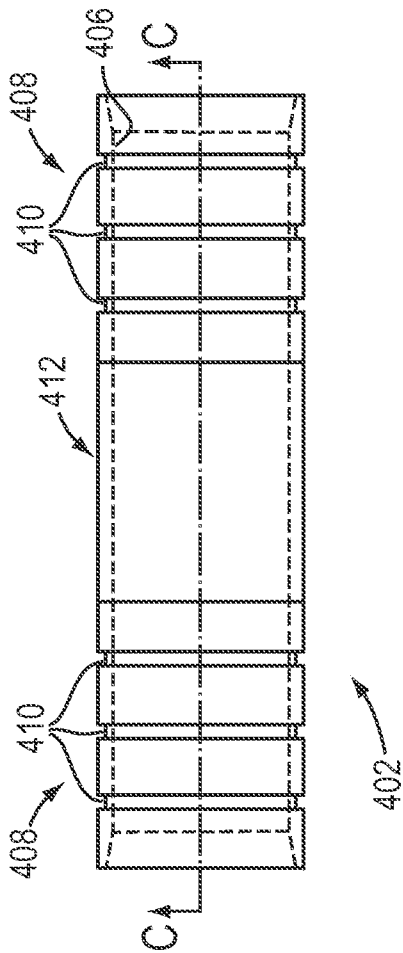

FIG. 5B

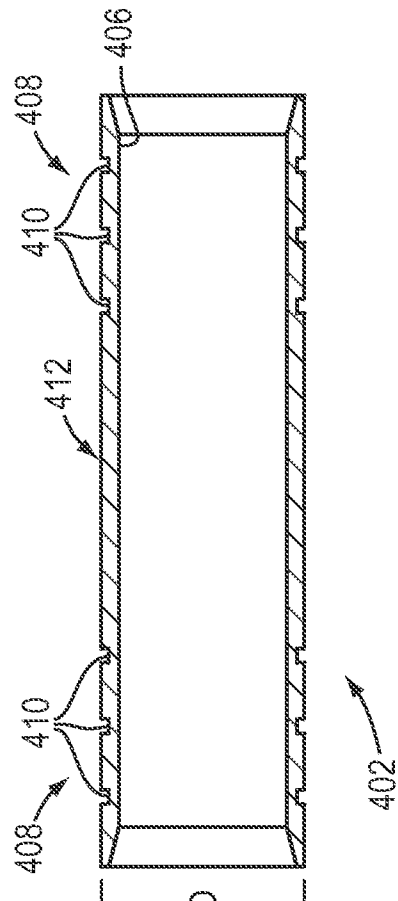

FIG. 5C



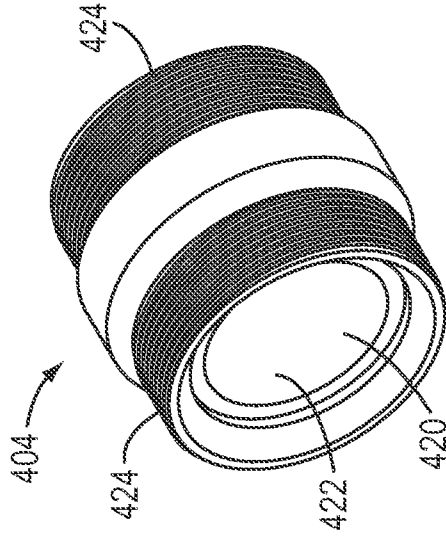

FIG. 6A

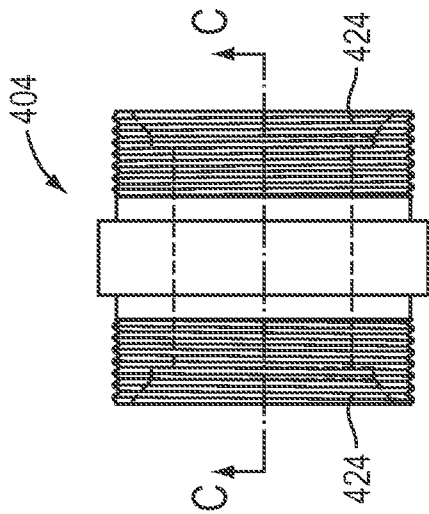

FIG. 6B

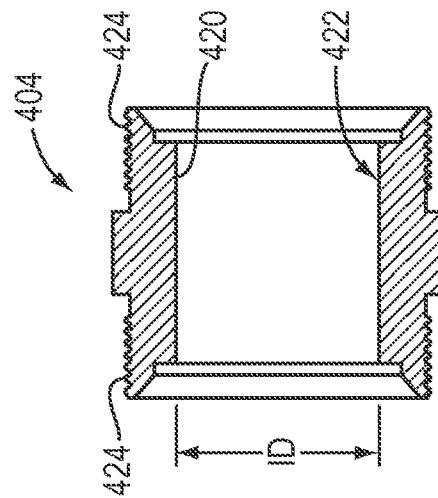

FIG. 6C

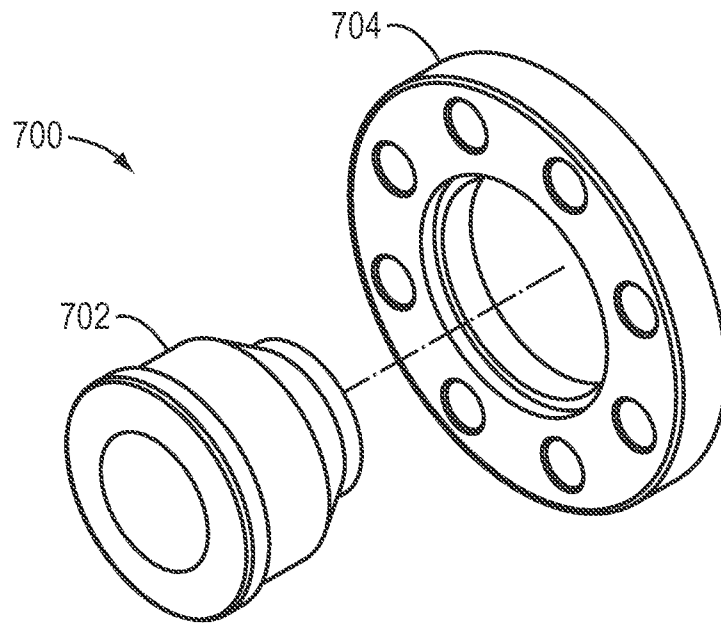

FIG. 7

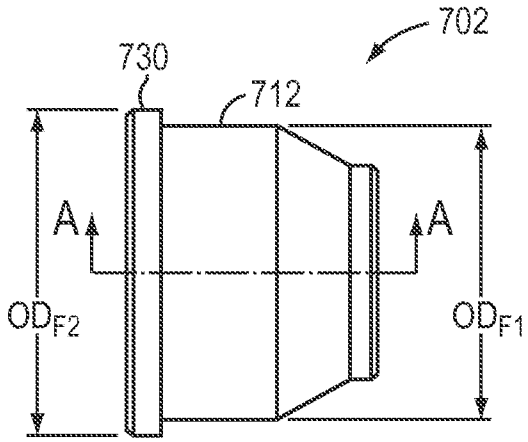

FIG. 8B

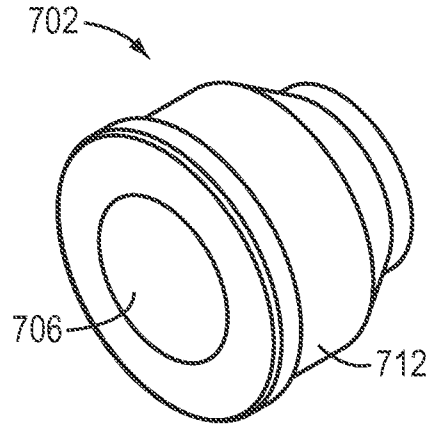

FIG. 8A

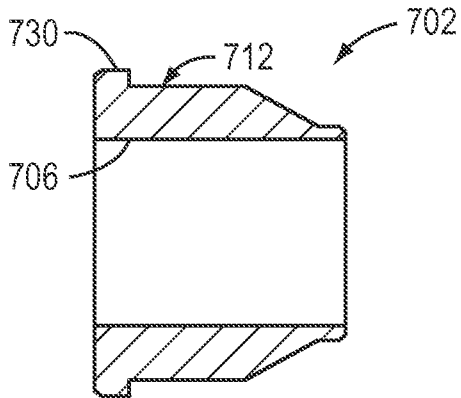

FIG. 8C

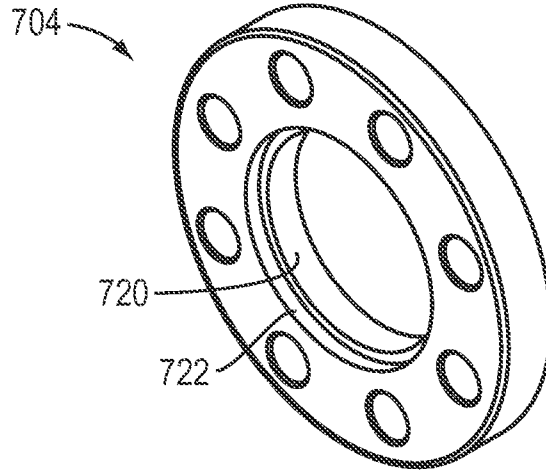

FIG. 9A

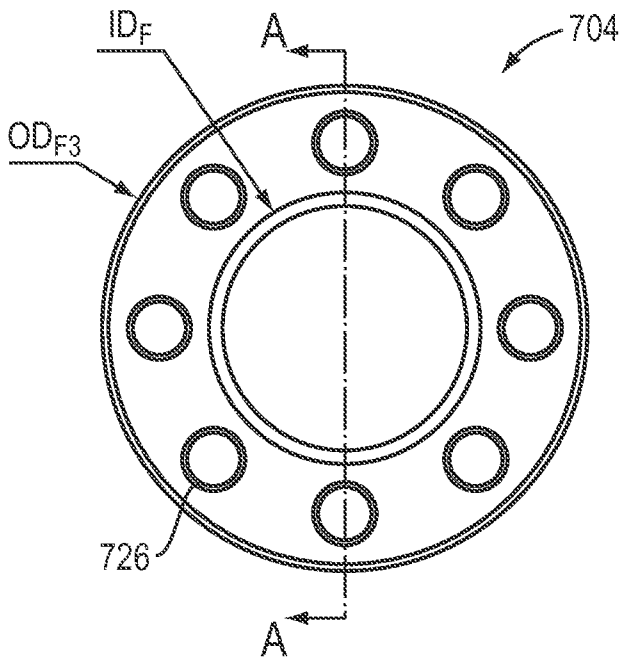

FIG. 9B

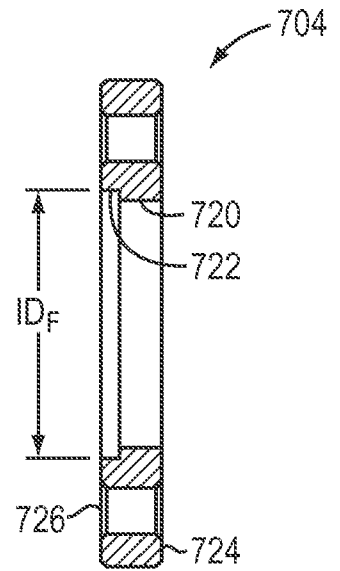
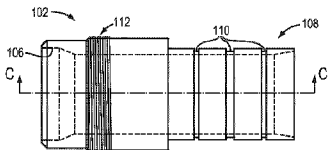
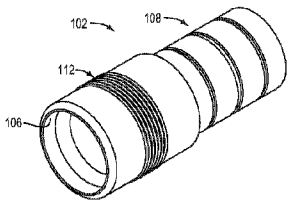

FIG. 9C



B



A

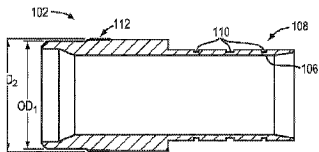

C

