

[72] Inventor **John Haller**
 Northville, Mich.
 [21] Appl. No **847,183**
 [22] Filed **Aug. 4, 1969**
 [45] Patented **July 20, 1971**
 [73] Assignee **Federal-Mogul Corporation**
 Southfield, Mich.

[54] **COMPOSITE WEAR-RESISTANT ARTICLES SUCH AS FACE SEALS**
 5 Claims, 14 Drawing Figs.

[52] U.S. Cl. 277/96
 [51] Int. Cl. F16j 15/34
 [50] Field of Search 277/96, 81, 224

References Cited

FOREIGN PATENTS

137,860 7/1950 Australia 277/96
 1,259,274 3/1961 France 277/96

Primary Examiner—Robert I. Smith
 Attorney—Barthel and Bugbee

ABSTRACT: A shallow groove in the flange of an annular radially-flanged briquette of powdered base metal, such as powdered iron, is filled with powder of a wear-resistant metal alloy of high retentive hardness, and this assembly heated to a sufficiently high temperature to simultaneously sinter the base metal briquette and melt the superalloy type powder, which thereupon bonds itself with the iron. The periphery of this composite body is then ground away to expose the superalloy type metal alloy and then finish-machined on its annular face to grind away the edges of the groove and reduce them to the level of the surrounding base metal, a slight inward taper being preferably imparted to the inner part of the hard metal portion.

In a modification, a separate annular briquette of metal alloy powder of wear-resistant high-retentive hardness is prepared in a size adapted to mate with the groove of the base metal briquette and inserted therein. Thereupon the base metal briquette and the hard metal insert are simultaneously heated to sinter the iron powder briquette and melt the hard metal alloy so that it bonds itself to the sintered powdered iron base metal. The resulting annular blank is then machined by grinding as in the principal form of the invention.

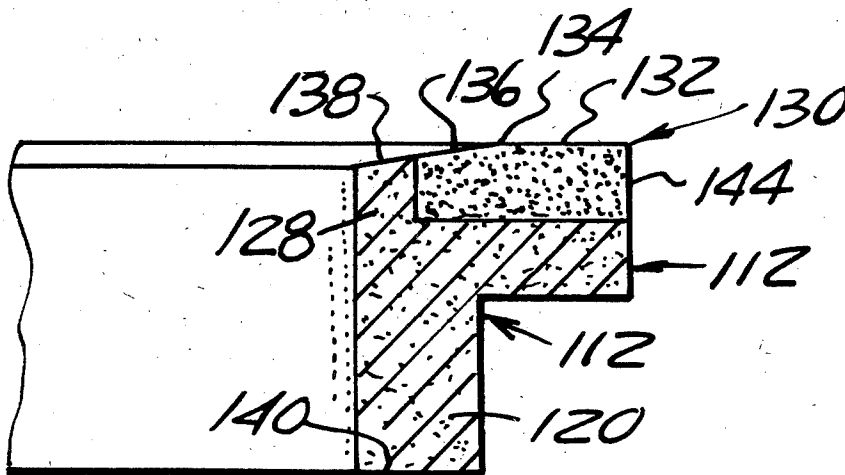

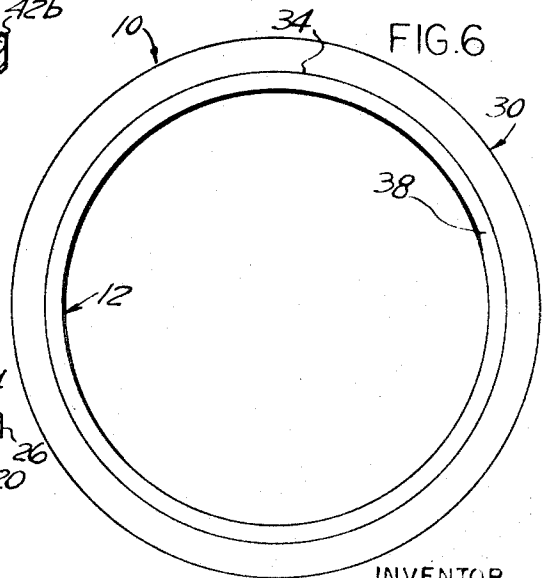
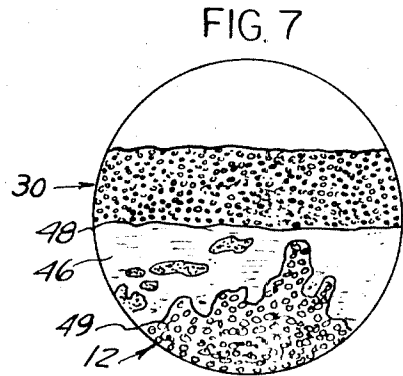
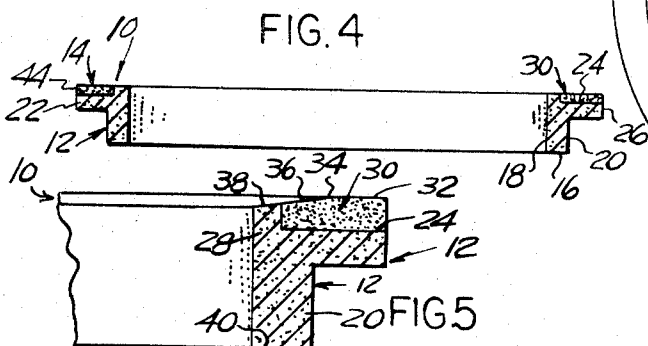
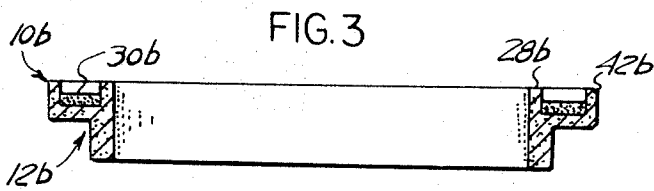
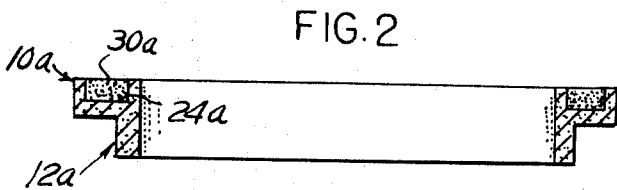
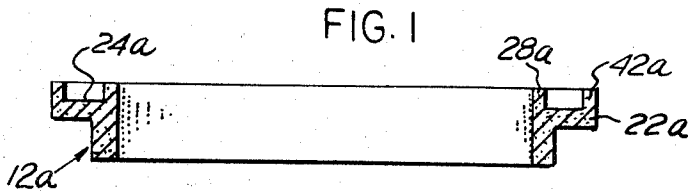

INVENTOR
JOHN HALLER
BY *Parthel & Buehler*
ATTORNEYS.

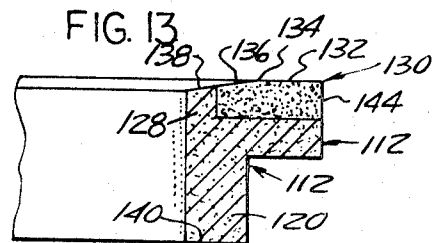
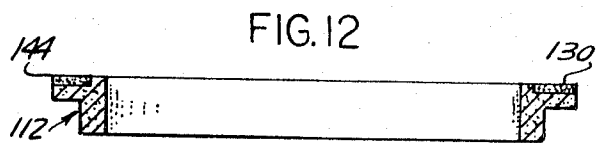
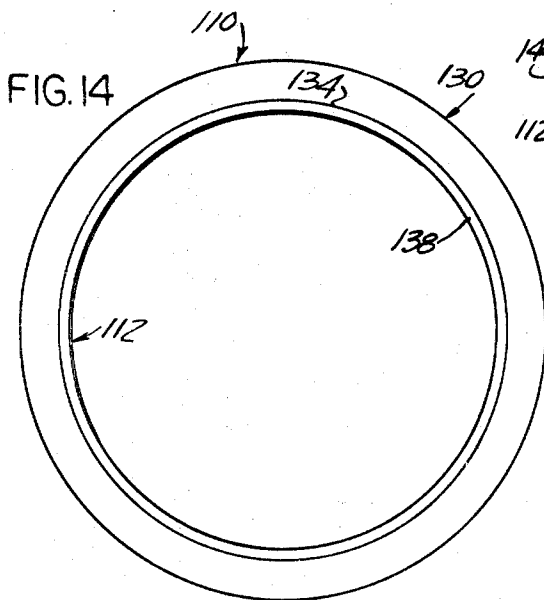
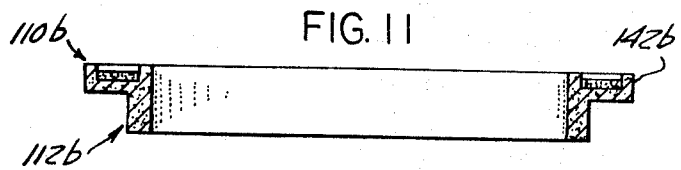
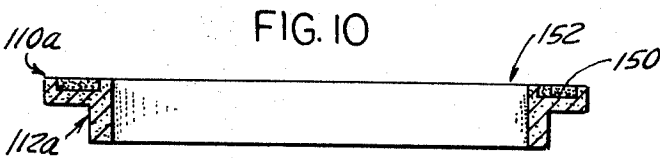
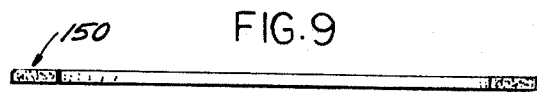
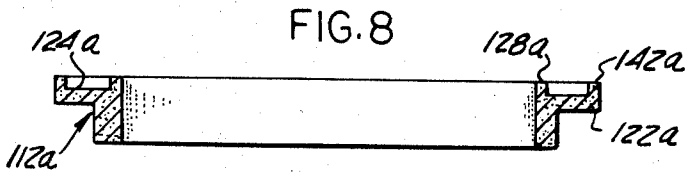

INVENTOR
JOHN HALLER
BY *Barthel & Buehler*
ATTORNEYS

COMPOSITE WEAR-RESISTANT ARTICLES SUCH AS FACE SEALS

BACKGROUND OF THE INVENTION

Hitherto, heavy duty face seals and other wear-resistant articles have required the use of super-hard exotic metals of high-retentive hardness for their composition, such as the super-hard alloy of high-retentive hardness of the super-alloy type. Prior to the present invention, these seals from such exotic metal alloys have been required to be cast, as they are too hard to be machined or otherwise formed except by grinding. Moreover, such exotic metal alloys themselves are extremely expensive and the grinding operations required to form them into shaped articles are also time-consuming with a consequently high expense of labor and abrasive grinding tools. The "superalloys", particularly some of the iron and cobalt-base types, have high hardness and show extremely good resistance to the effects of galling and seizing. In many cases their low coefficients of friction allow sliding contact with other metals without damage by metal pickup. Excellent applications of these alloys (because of their antigalling properties) are burnishing rollers, shaft sleeves, and metal-to-metal seal rings. The iron-base alloys of interest in this invention have a lower melting point than cobalt-base or nickel-base alloys, and are more suitable for use. Some of these alloys may be heat-treated to high hardness levels, making them extremely useful in many wear applications.

SUMMARY OF THE INVENTION

The present invention strikingly reduces the cost of heavy-duty face seals or other wear-resistant articles by forming the mounting portion of such face seals by powder metallurgy from inexpensive sintered powdered base metals which require little or no machining and constitute the major part of the seal not exposed to severe wear or heat. An annular portion of powdered super-hard exotic metal of high-retentive hardness is placed in an annular groove formed in a briquette of the base metal. Sintering of the base metal is carried out at a temperature which at the same time melts the exotic metal and bonds it securely to the base metal. The face and periphery of the composite blank thus formed are then ground away to expose the facing of the super-hard metal alloy of high-retentive hardness.

In the drawings:

FIG. 1 is a cross section through a grooved annular powdered base metal briquette used in forming the composite face seal of the present invention;

FIG. 2 is a cross section through the base metal briquette of FIG. 1, after the groove thereof has been filled with hard metal alloy powder of high-retentive hardness;

FIG. 3 is a view similar to FIG. 2, but showing the appearance of the parts after sintering;

FIG. 4 is a view similar to FIG. 3, but showing the appearance of the parts after the periphery and face of the composite sintered powdered metal body have been ground away to expose the hard metal alloy portion thereof;

FIG. 5 is an enlarged view of the right-hand end of FIG. 4, showing the slight taper formed on the inner part of the hard metal alloy portion of the seal during grinding;

FIG. 6 is a top plan view of the composite sintered powdered metal face seal shown in FIGS. 4 and 5;

FIG. 7 is a reproduction of a photomicrograph of a section through the rim portion of FIG. 4, magnified 100 diameters, showing the interengagement and interlocking of the bond between the base metal portion and the super-hard alloy portion;

FIG. 8 is a cross section through a base metal briquette used in forming the modified composite face seal according to the present invention;

FIG. 9 is a cross section through a briquette of powdered hard metal alloy formed to fit into the face groove of the briquette of FIG. 8;

FIG. 10 is a cross section similar to FIG. 8, after the briquette of FIG. 9 has been inserted in the groove of the briquette of FIG. 8;

FIG. 11 is a view similar to FIG. 10, but showing the appearance of the parts after sintering;

FIG. 12 is a view similar to FIG. 11 but showing the appearance of the parts after the periphery and face of the composite sintered powdered metal body has been ground away to fully expose the hard metal alloy portion thereof;

FIG. 13 is an enlarged view of the right-hand end of FIG. 12, again showing the slight taper formed on the inner part of the hard metal alloy portion of the seal during grinding; and

FIG. 14 is a top plan view of the composite sintered powdered metal face seal shown in FIGS. 12 and 13.

Referring to the drawings in detail, FIGS. 4, 5 and 6 show a composite heavy-duty face seal, generally designated 10, according to one form of the invention, as consisting of a radially-flanged sintered powdered base metal mounting ring 12 containing an annular face portion 14 of a sintered hard metal alloy of high-retentive hardness or so-called superalloy. The base metal mounting ring 12 consists of a cylindrical portion 16 with a cylindrical bore 18 and a cylindrical outer surface 20 from which a radial flange 22 projects outward from the cylindrical portion 16 and has a recess 24 (FIG. 5) extending out to the periphery 26 thereof and inward to an annular axial portion 28 of the base ring 12. Bonded into the recess 24 in the manner described below is an annular insert 30 of a hard metal alloy of high-retentive hardness, namely an exotic metal such as stellite or the like. The insert 30 has a flat radial outer face surface 32 extending inward to a circular boundary line 34, beyond which an inwardly-tapered surface 36 extends inward across the face 38 of the axial base metal mounting ring portion 28 to the bore 18. The mounting ring 12 has a flat or radial rearward surface 40.

In producing the composite face seal 10 of the present invention, shown in FIGS. 4, 5 and 6, the operator first prepares an annular flanged briquette 12a (FIG. 1) of base metal powder, such as powdered iron, having a shape corresponding to the mounting ring portion 12 of the final composite face seal 10, but having a groove 24a formed in the flange 22a and having inner and outer sidewalls 28a and 42a. The briquette 12a is formed in a conventional powdered briquetting press by conventional briquetting methods, well known to those skilled in this art and requiring no elaboration. After the powdered base metal briquette 12a has been prepared in the above manner, its groove 24a is filled with loose powder 30a of a hard metal alloy of high-retentive hardness, such as that alloy known to metallurgists under the name "stellite" to form a powder-filled base metal briquette 12a (FIG. 2).

The thus powder-filled base metal briquette 12a is then transferred to a sintering furnace and sintered at a temperature in the neighborhood of 2150° F. to 2200° F. (for so-called alloy No. 93), sufficiently high to simultaneously sinter the powdered base metal briquette 12a and melt the hard metal alloy powder 30a so that the latter solidifies into an annular solid hard-metal portion 30b. The latter becomes bonded into the sintered powdered base metal mounting ring 12b forming the annular composite blank 10b with axially-projecting annular shoulders 28b and 42b (FIG. 3). After cooling, the composite blank 10b (FIG. 3) is transferred to a conventional grinder which edge grinds the peripheral shoulder 42b until the periphery of the solid hard metal insert 30b is exposed at 44 (FIG. 4). The thus partially completed face seal 10b is then face ground to form the flat radial outer face surface 32 and subsequently form the inwardly-tapered or shallow conical surfaces 36 and 38 (FIG. 5) beyond the circular boundary line 34. The result is the composite heavy-duty face seal 10 shown in FIGS. 4, 5 and 6.

The bonded condition of the super-hard solid metal portion 30 with the base metal 12 (FIG. 7) takes place at an interlayer 46 which is a mixture of the hard metal from the portion 30 and the base metal from the portion 12, wherein the crystalline structure interlocks between two indefinite and irregular

boundary surfaces 48 and 49 respectively. The interaction of the base metal and the hard metal alloy in this manner creates a tough and permanent union between the two metals which resists separation even under the most extreme heavy-duty conditions of use.

The modified process illustrated in FIGS. 8 to 14 inclusive follows a somewhat similar procedure except that instead of employing loose powder for the exotic metal, it employs a briquette thereof. Accordingly, since many of the parts and portions of the components shown in FIGS. 8 to 14 inclusive are similar to those of FIGS. 1 to 6 inclusive, similar parts in FIGS. 8 to 14 inclusive are designated with the same reference numerals increased by 100. The face seal 110 produced by the process of FIGS. 8 to 14 inclusive is substantially identical to the face seal shown in FIGS. 4 to 6 inclusive.

As in the above-described process, the operator first prepares from powdered base metal an annular flanged base metal briquette 112a (FIG. 8) like the briquette 12a of FIGS. 1 and 2, with a similar groove 124a formed in the flange 122a thereof with outer and inner groove sidewalls 142a and 128a. The modified process, however, diverges at this point in that the operator prepares an annular briquette 150 (FIG. 9) of the same size as the groove 124a and formed by compressing the exotic metal alloy powder in a conventional briquetting press by conventional briquetting procedures. The unsintered or "green" insert briquette 150 is then placed in the groove 124a of the also unsintered metal briquette 112a (FIG. 10) and this assembly 152 is then transferred to a conventional sintering furnace (not shown). The assembly 152 is then sintered at a temperature in the neighborhood of 2150° F. to 2200° F. (for so-called alloy No. 93) so as to simultaneously sinter the powdered base metal briquette 112a and melt the super-hard powdered metal alloy briquette 150. As a result, the insert briquette 150 melts and its lower surface portion comingles with the base metal at the bottom of the groove 124a (FIG. 11) forming a bonded interlayer similar to that shown at 46 in FIG. 7.

As before, the resulting composite blank 110b (FIG. 11) is then transferred to a conventional grinder which edge-grinds the peripheral shoulder 142b completely away so as to expose the now solid hard metal insert 130b at 144 (FIG. 12). The thus partially completed face seal 110b is then face ground to form the flat radial outer face surface 132 (FIG. 13) and subsequently forms the inwardly-tapered or shallow conical surfaces 136 and 138 meeting the annular outer surface 132 at the circular boundary line 134. The result is the composite heavy-duty face seal 110 shown in FIGS. 12, 13 and 14. As before, in connection with FIG. 7, the bonded condition of the

super-hard solid metal alloy portion 130 with the base metal portion 112 takes place at an inter-layer similar to the inter-layer 46 of FIG. 7 and the same description of its properties applies as described above in connection with FIG. 7.

In carrying out the above-described process and the modification thereof, the provision of the annular grooves in the faces of the base metal mounting rings retains the molten super-hard metal in position during sintering and prevents it from running off, as well as giving an even thickness of the insert metal.

In the use of the composite heavy-duty face seal of the present invention, as the flat outer peripheral face surface 32 or 132 wears away, it widens in a radial direction, thereby increasing the load-bearing area, as is clearly seen from FIGS. 5 and 13.

I claim:

1. A composite wear-resistant article, such as a heavy-duty face seal comprising
 - an annular mounting member of sintered powdered base metal having a substantially radial face with an annular recess therein,
 - an annular insert member of sintered powdered hard material of high-retentive hardness secured to said mounting member within said recess in mating engagement therewith,
 - and a commingled interlayer of said base metal and said hard material interposed in said recess between said mounting member and said insert member in interlocking bonding relationship therebetween.
2. A composite wear-resistant article, according to claim 1, wherein said mounting member has an annular flange with said radial face thereon, and wherein said annular recess is disposed in said radial face of said flange.
3. A composite wear-resistant article, according to claim 2, wherein the surface of said insert in said radial face is disposed higher than the surface of said base member in said radial face.
4. A composite wear-resistant article, according to claim 3, wherein the outer portion of said insert surface adjacent the outer periphery of said flange is substantially flat, and wherein the inner portion of said insert and the inner portion of said base member surface adjacent the inner periphery of said flange are concavely conical.
5. A composite wear-resistant article, according to claim 1, wherein said hard material of said insert member comprises sintered powdered hard metal alloy disposed in said recess, and wherein said base metal of said mounting member comprises sintered powdered ferrous metal.

50

55

60

65

70

75