



US00D383193S

# United States Patent [19]

[11] Patent Number: Des. 383,193

Heren et al.

[45] Date of Patent: \*\*Sep. 2, 1997

[54] WAVE SPRINKLER

[57] CLAIM

[75] Inventors: Lawrence P. Heren, East Peoria, Ill.;  
Thomas R. Krueger, Edgewood, Ky.;  
Ronald G. Hayes, Milford, Ohio

The ornamental design for a wave sprinkler, as shown and described.

[73] Assignee: L. R. Nelson Corporation, Peoria, Ill.

### DESCRIPTION

[\*\*] Term: 14 Years

FIG. 1 is a top plan view of a twenty nozzle embodiment of a wave sprinkler showing our new design;

[21] Appl. No.: 39,777

FIG. 2 is a right side elevational view thereof, the left side elevational view being a mirror image thereof;

[22] Filed: May 26, 1995

FIG. 3 is a front elevational view thereof;

### Related U.S. Application Data

FIG. 4 is a rear elevational view thereof;

[63] Continuation-in-part of Ser. No. 25,535, Jun. 1, 1994, abandoned, and a continuation-in-part of Ser. No. 25,533, Jun. 1, 1994, abandoned, and a continuation-in-part of Ser. No. 25,534, Jun. 1, 1994, abandoned.

FIG. 5 is a bottom plan view thereof;

[51] LOC (6) Cl. .... 23-01

FIG. 6 is a top plan view of a sixteen nozzle embodiment of a wave sprinkler showing our new design;

[52] U.S. Cl. .... D23/216

FIG. 7 is a right side elevational view thereof, the left side elevational view being a mirror image thereof;

[58] Field of Search ..... D23/213-217;  
239/222.13, 222.21, 225.1, 230-33, 240-242,  
390, 248, 263, 562, 563, DIG. 1

FIG. 8 is a front elevational view thereof;

FIG. 9 is a rear elevational view thereof;

FIG. 10 is a bottom plan view thereof;

FIG. 11 is a top plan view of a twenty nozzle embodiment of a wave sprinkler with a flow control showing our new design;

FIG. 12 is a right side elevational view thereof, the left side elevational view being a mirror image thereof;

FIG. 13 is a front elevational view thereof;

FIG. 14 is a rear elevational view thereof;

FIG. 15 is a bottom plan view thereof;

FIG. 16 is a top plan view of a sixteen nozzle embodiment of a wave sprinkler with flow control showing our new design;

FIG. 17 is a right side elevational view thereof, the left side elevational view being a mirror image thereof;

FIG. 18 is a front elevational view thereof;

FIG. 19 is a rear elevational view thereof;

FIG. 20 is a bottom plan view thereof;

FIG. 21 is a top plan view of a twenty nozzle embodiment of a wave sprinkler with a flow control and spray width adjustment showing our new design;

FIG. 22 is a right side elevational view thereof, the left side elevational view being a mirror image thereof;

FIG. 23 is a front elevational view thereof;

FIG. 24 is a rear elevational view thereof;

FIG. 25 is a bottom plan view thereof;

### [56] References Cited

#### U.S. PATENT DOCUMENTS

D. 303,283	9/1989	Best et al.	.....	D23/216
D. 315,395	3/1991	Clivio	.....	D23/216
D. 321,034	10/1991	Whitehead	.....	D23/216
D. 334,422	3/1993	Clivio	.....	D23/216
D. 350,809	9/1994	Aquilina	.....	D23/216
4,606,500	8/1986	Mussler et al.	.....	239/242
4,877,185	10/1989	Kufrin	.....	239/242
5,098,020	3/1992	Cooper et al.	.....	239/242
5,305,956	4/1994	Wang	.....	239/394
5,350,115	9/1994	Burnworth et al.	.....	239/563

Primary Examiner—A. Hugo Word  
Assistant Examiner—Robin V. Taylor  
Attorney, Agent, or Firm—Daniel J. Hulseberg; Mayer, Brown & Platt

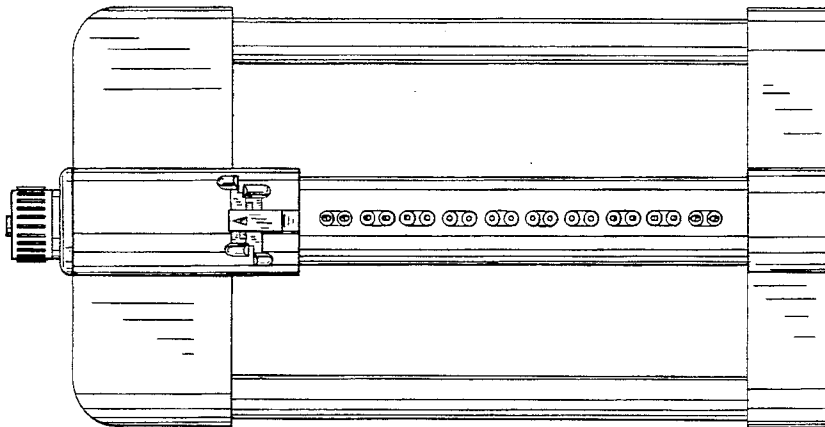

FIG. 26 is a top plan view of a sixteen nozzle embodiment of a wave sprinkler with flow control and spray width adjustment showing our new design;

FIG. 27 is a right side elevational view thereof, the left side elevational view being a mirror image thereof;

FIG. 28 is a front elevational view thereof;

FIG. 29 is a rear elevational view thereof;

FIG. 30 is a bottom plan view thereof;

FIG. 31 is a top plan view of a twenty nozzle embodiment of a wave sprinkler with a timer control showing our new design;

FIG. 32 is a right side elevational view thereof, the left side elevational view being a mirror image thereof;

FIG. 33 is a front elevational view thereof;

FIG. 34 is a rear elevational view thereof;

FIG. 35 is a bottom plan view thereof;

FIG. 36 is a top plan view of a sixteen nozzle embodiment of a wave sprinkler with timer control showing our new design;

FIG. 37 is a right side elevational view thereof, the left side elevational view being a mirror image thereof;

FIG. 38 is a front elevational view thereof;

FIG. 39 is a rear elevational view thereof;

FIG. 40 is a bottom plan view thereof;

FIG. 41 is a top plan view of a twenty nozzle embodiment of a wave sprinkler with a timer control and spray width adjustment showing our new design;

FIG. 42 is a right side elevational view thereof, the left side elevational view being a mirror image thereof;

FIG. 43 is a front elevational view thereof;

FIG. 44 is a rear elevational view thereof;

FIG. 45 is a bottom plan view thereof;

FIG. 46 is a top plan view of a sixteen nozzle embodiment of a wave sprinkler with timer control and spray width adjustment showing our new design;

FIG. 47 is a right side elevational view thereof, the left side elevational view being a mirror image thereof;

FIG. 48 is a front elevational view thereof;

FIG. 49 is a rear elevational view thereof; and,

FIG. 50 is a bottom plan view thereof.

**1 Claim, 40 Drawing Sheets**

FIG. 1

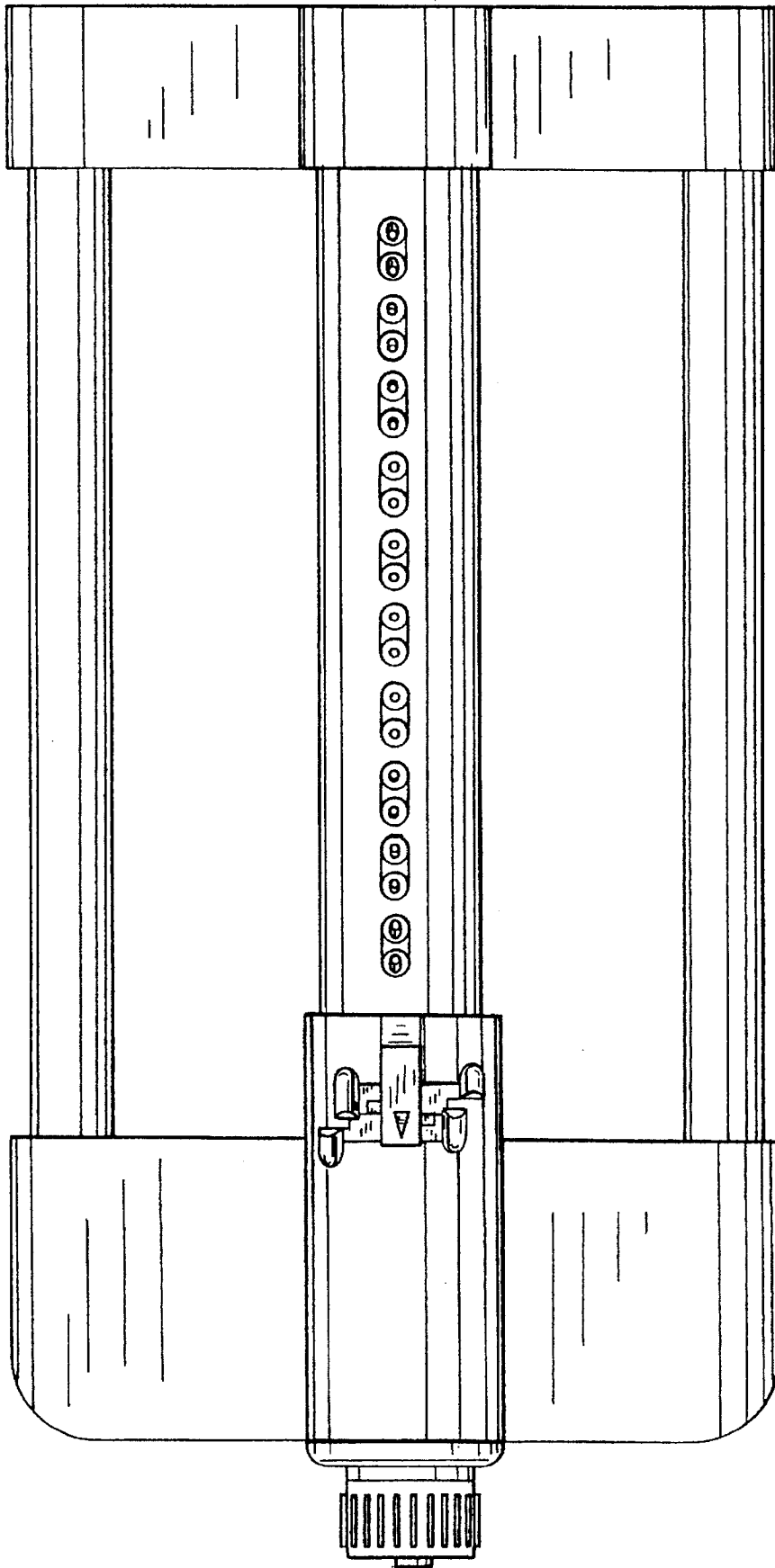

FIG. 2

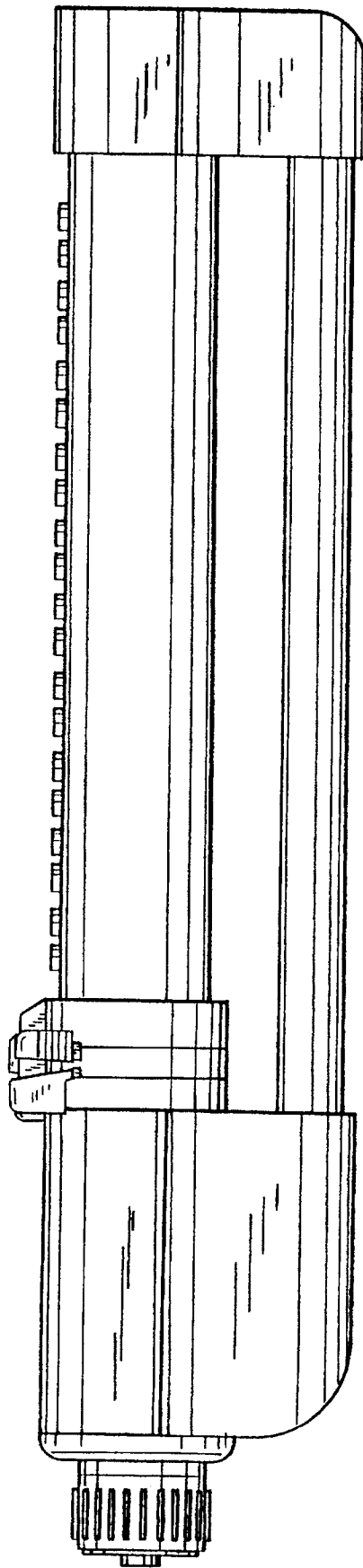

FIG. 3

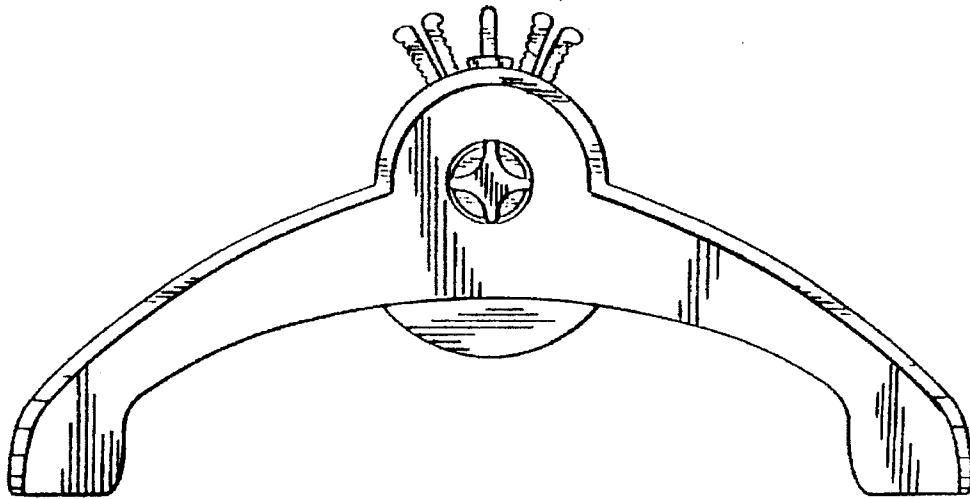

FIG. 4

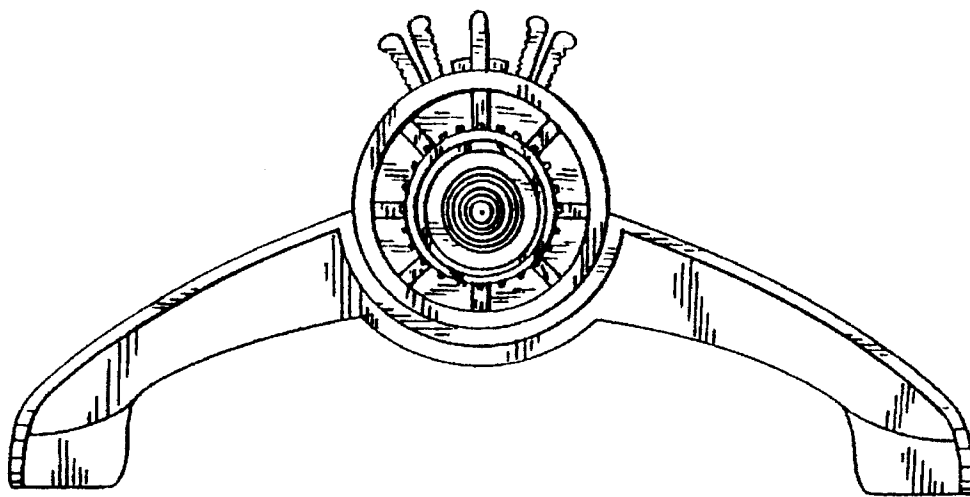

FIG. 5

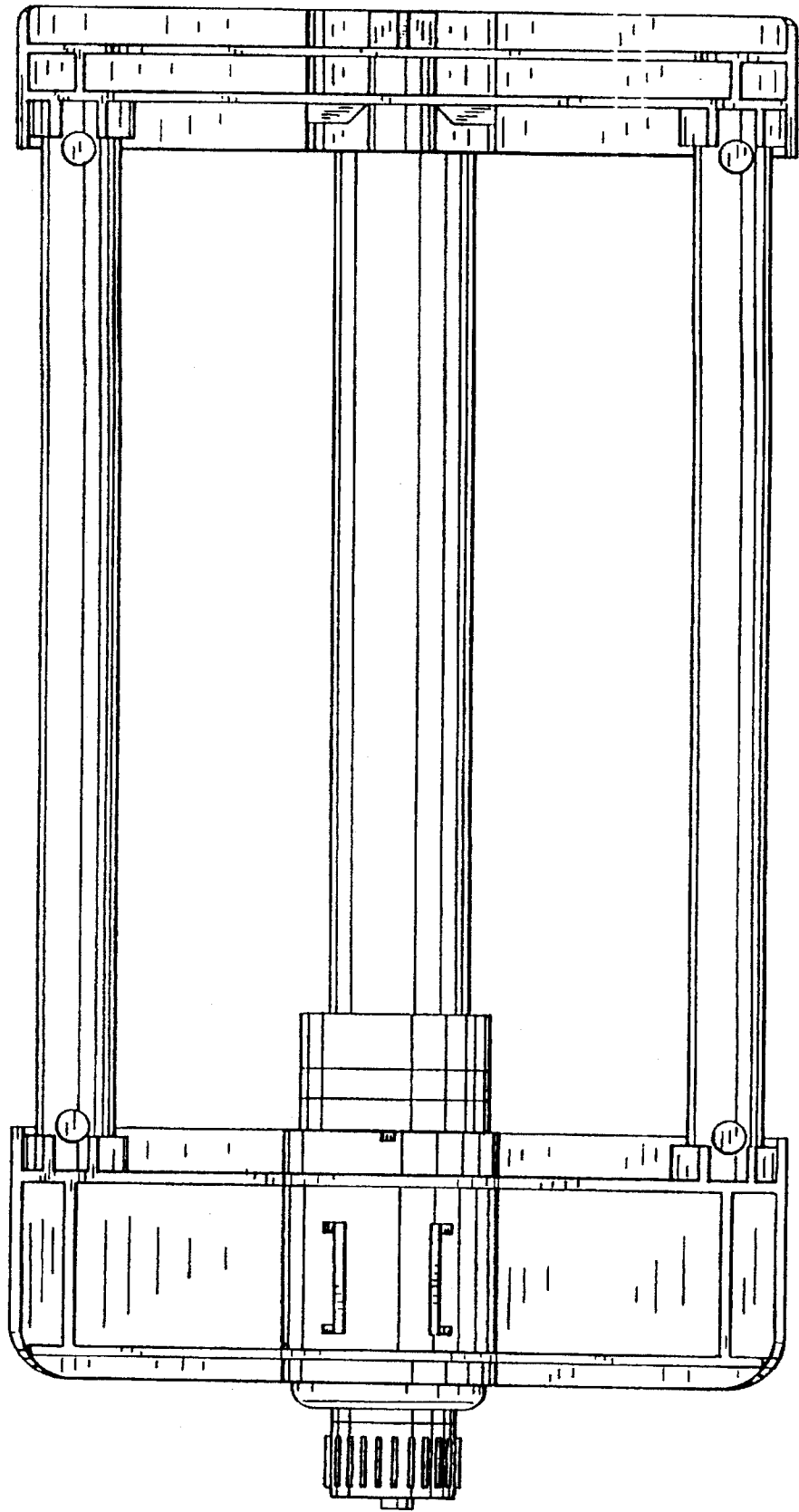

FIG. 6

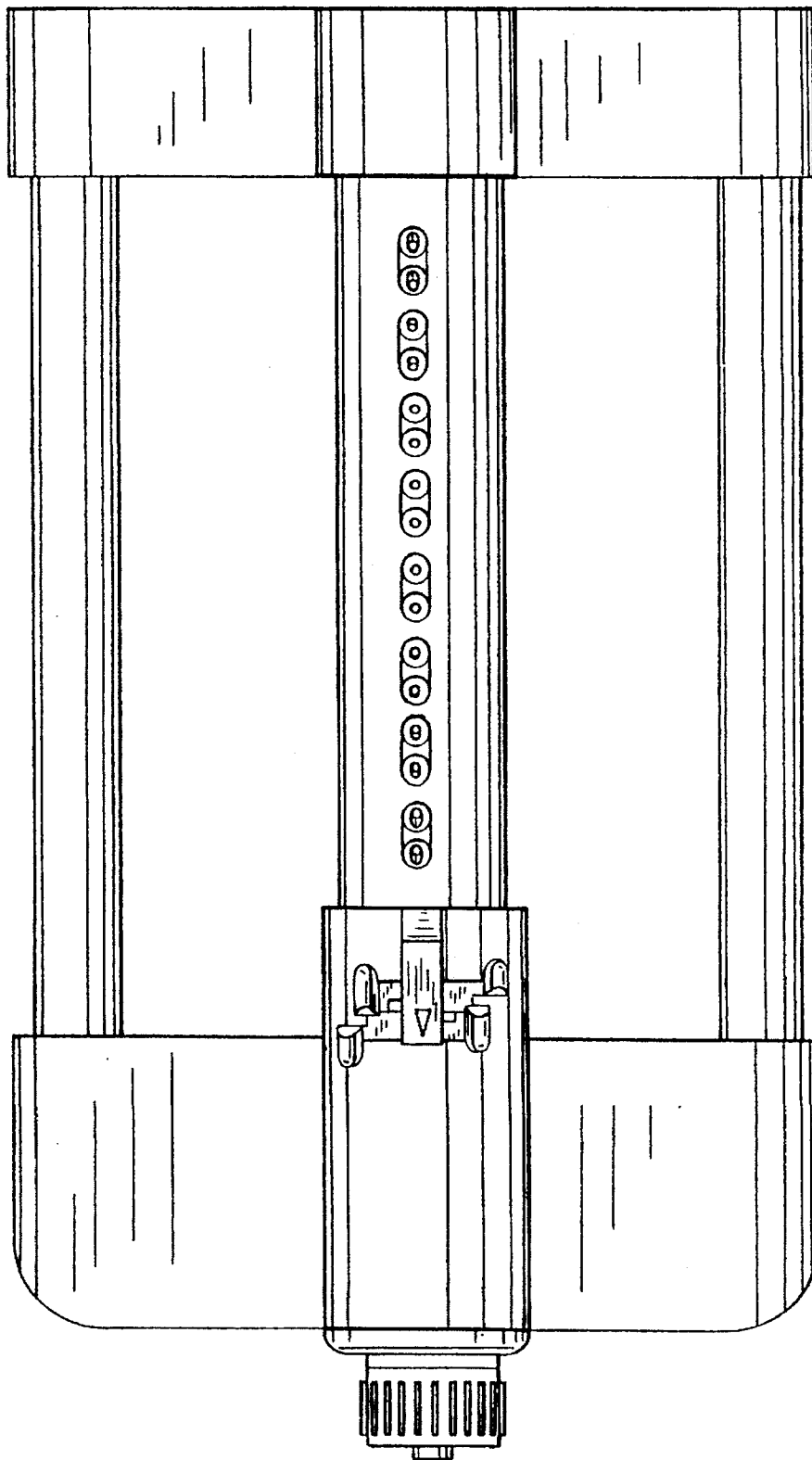

FIG. 7

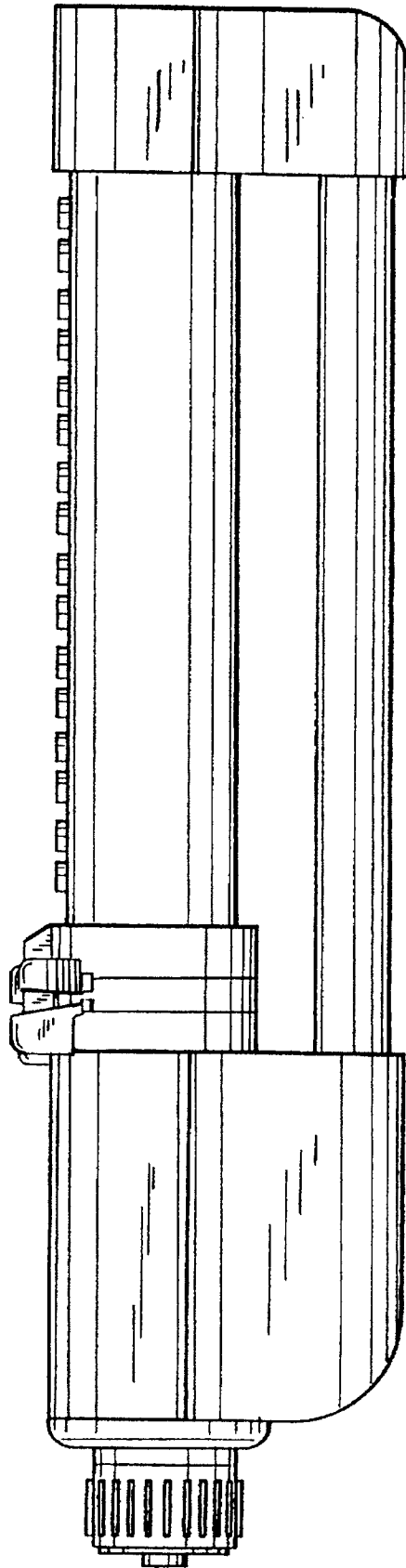



FIG. 8

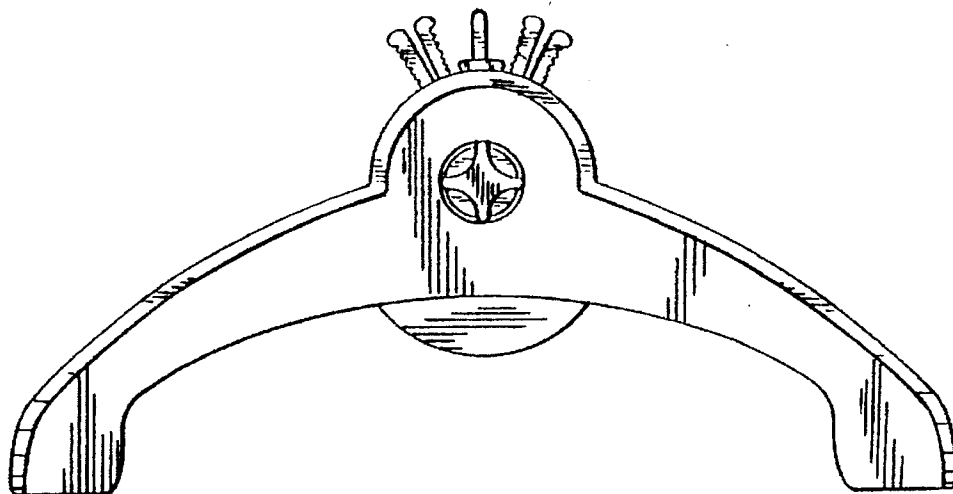

FIG. 9

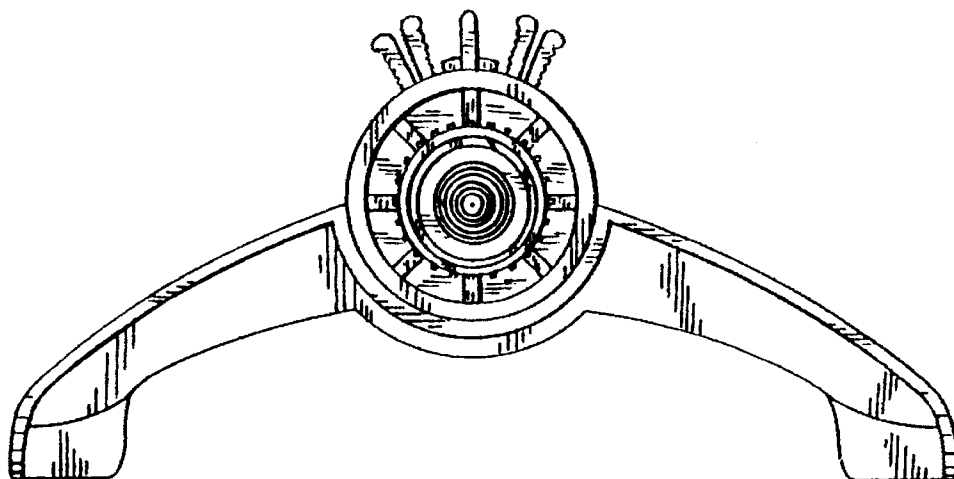

FIG. 10

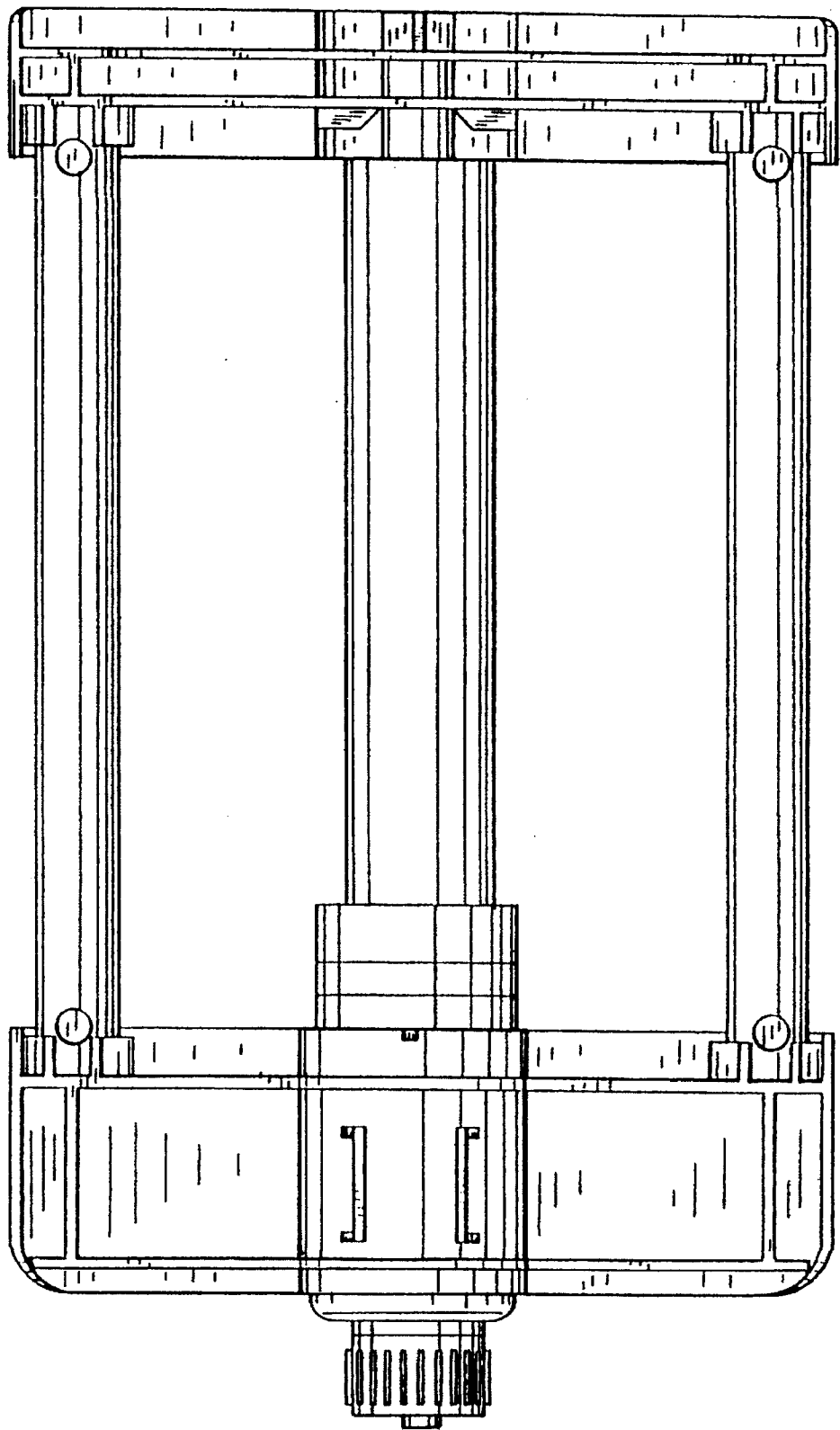

FIG. 11

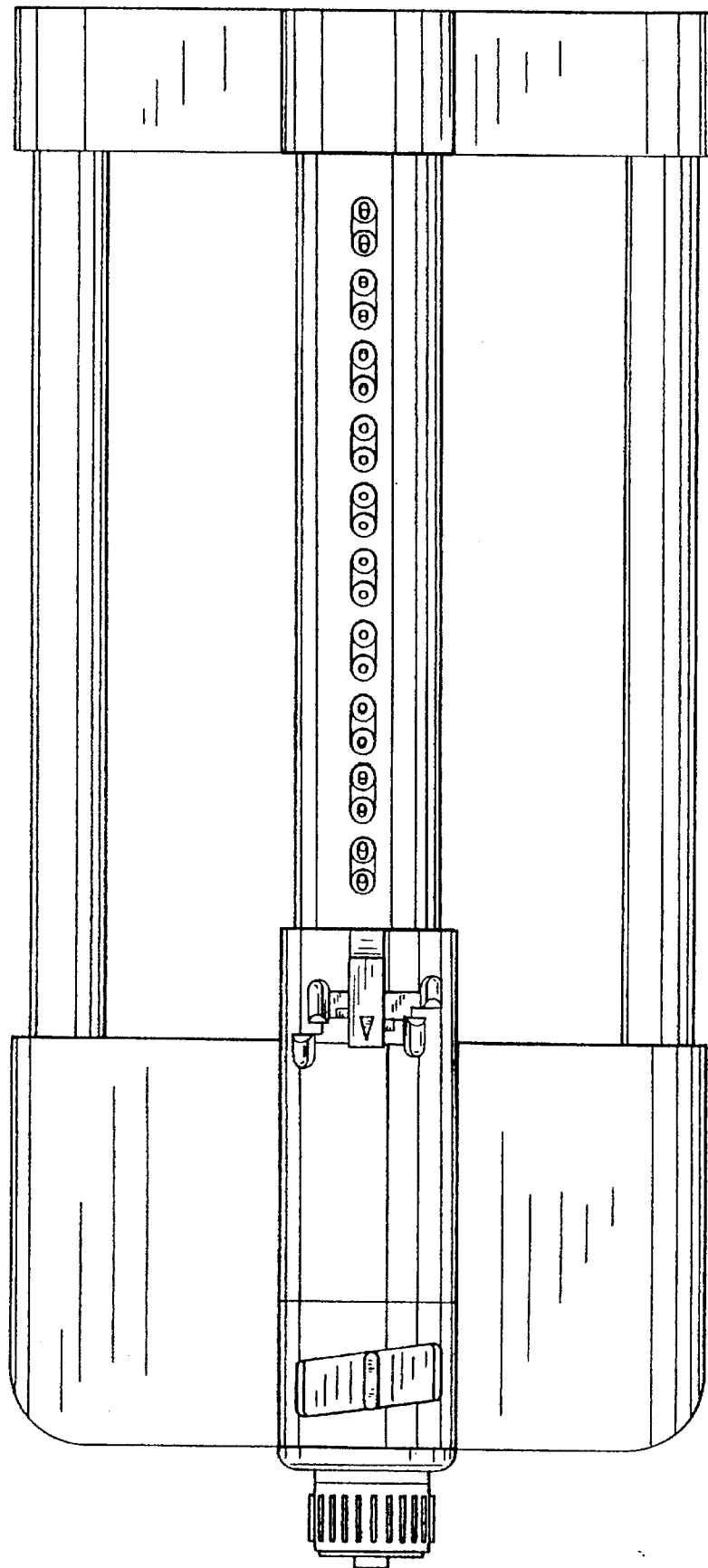

FIG. 12

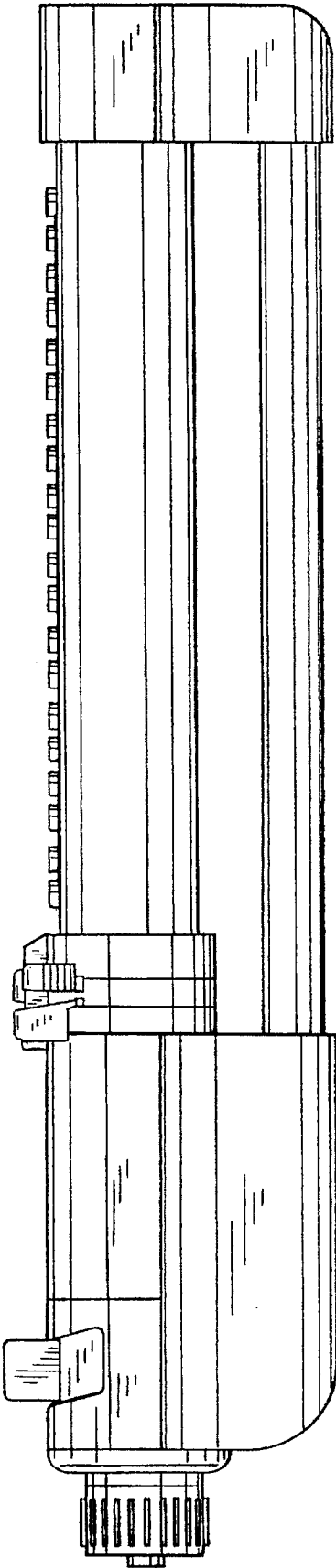

FIG. 13

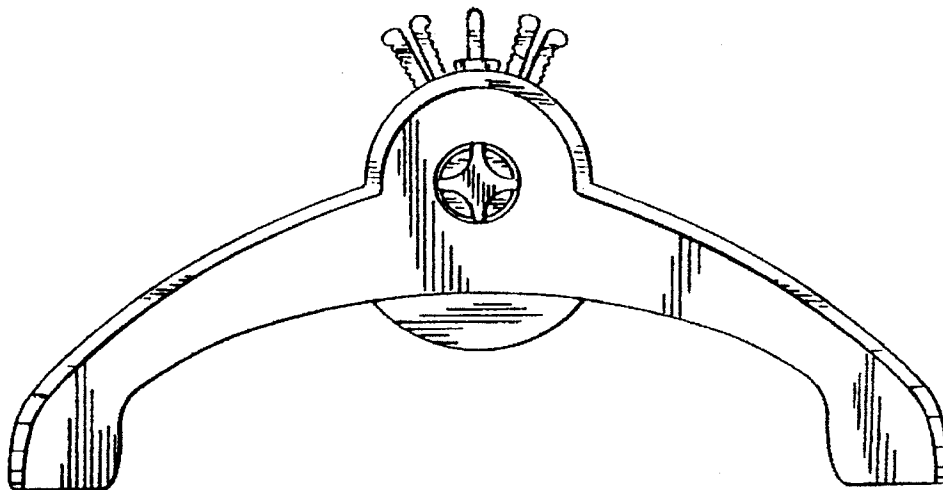

FIG. 14

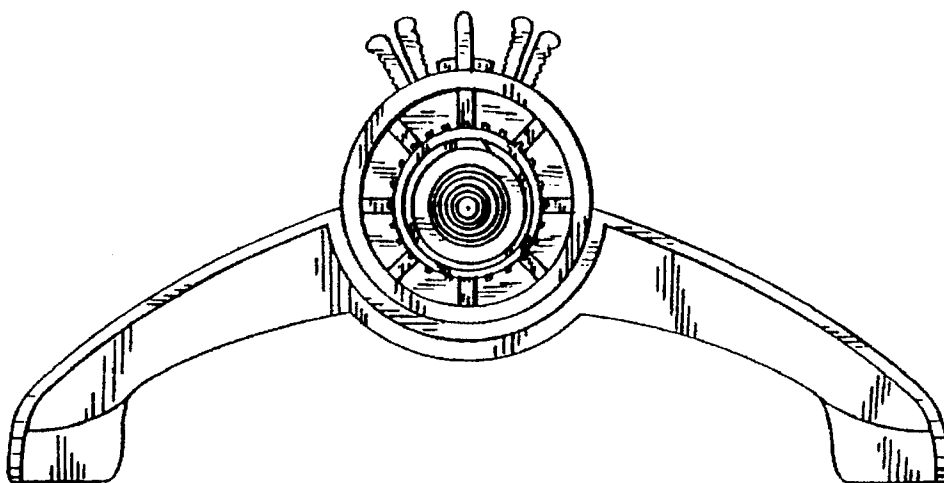

FIG. 15

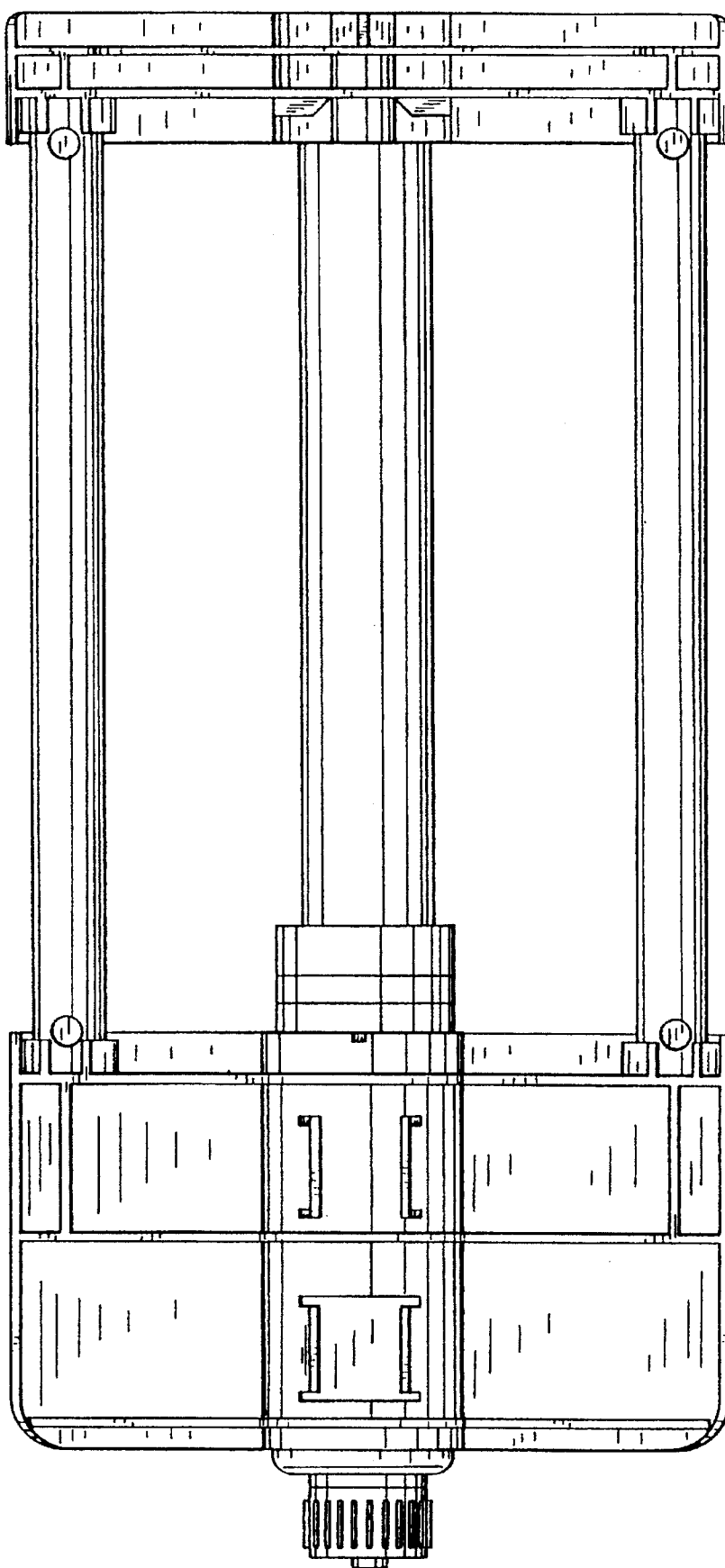

FIG. 16

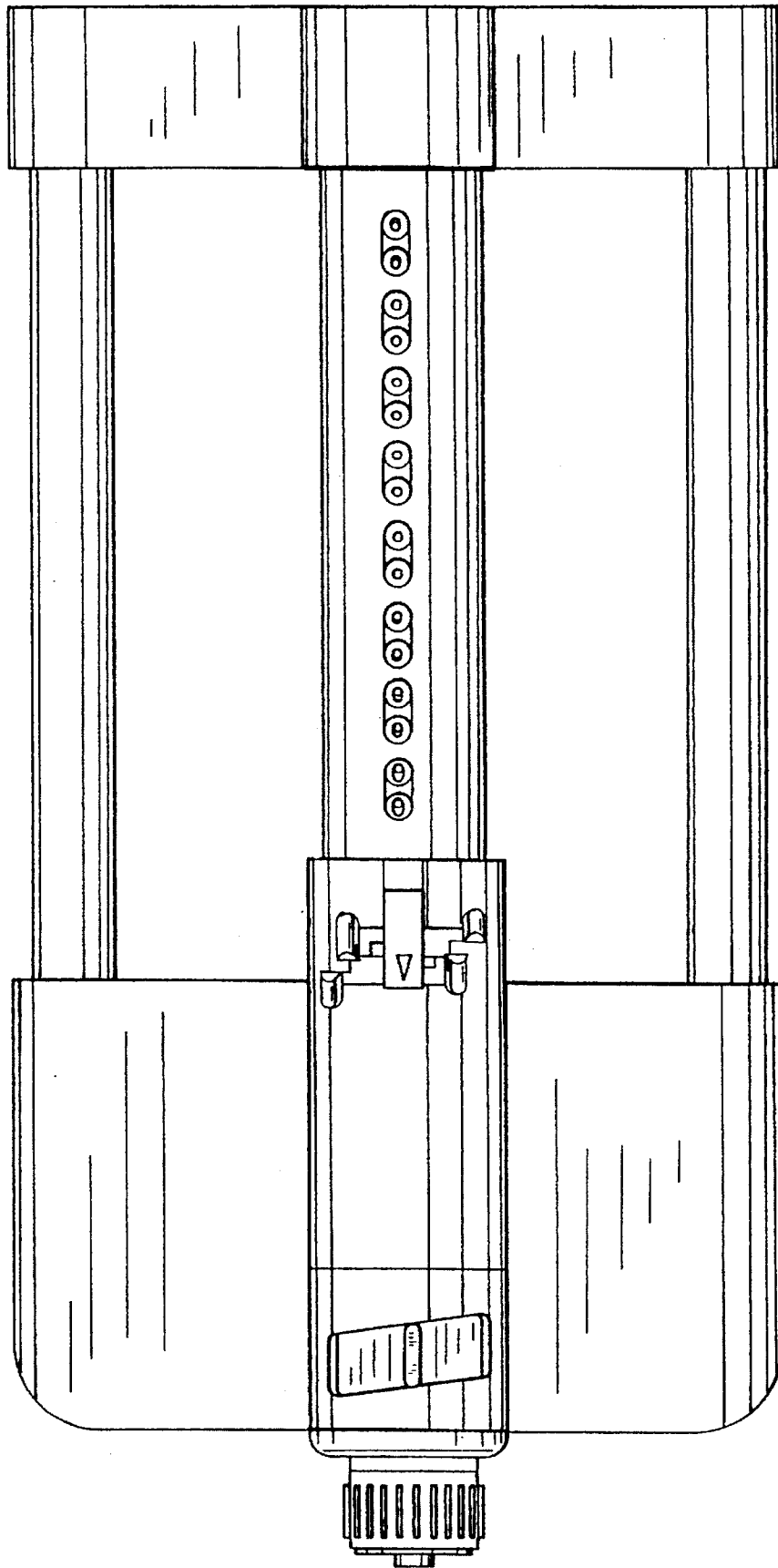

FIG. 17

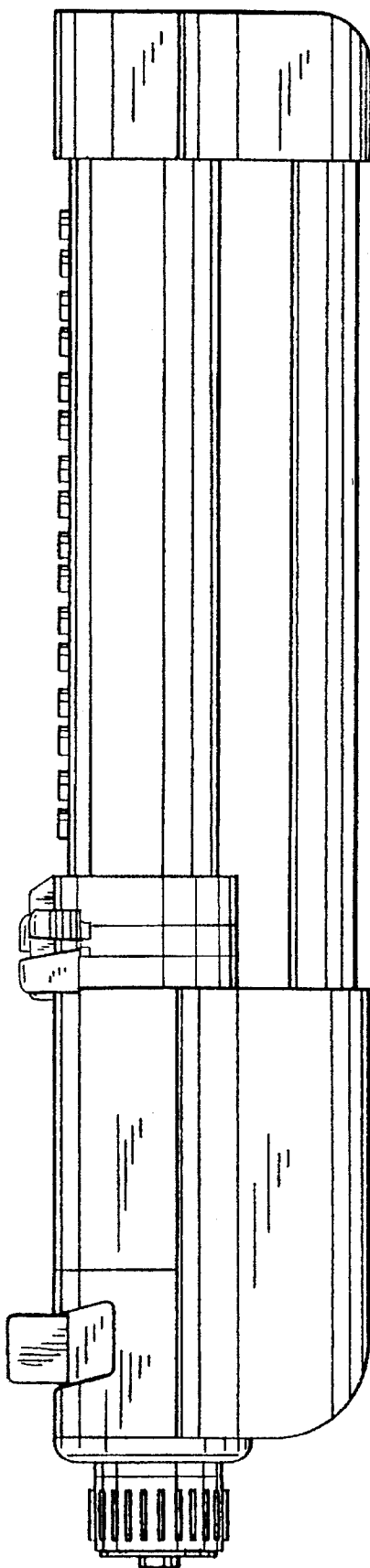



FIG. 18

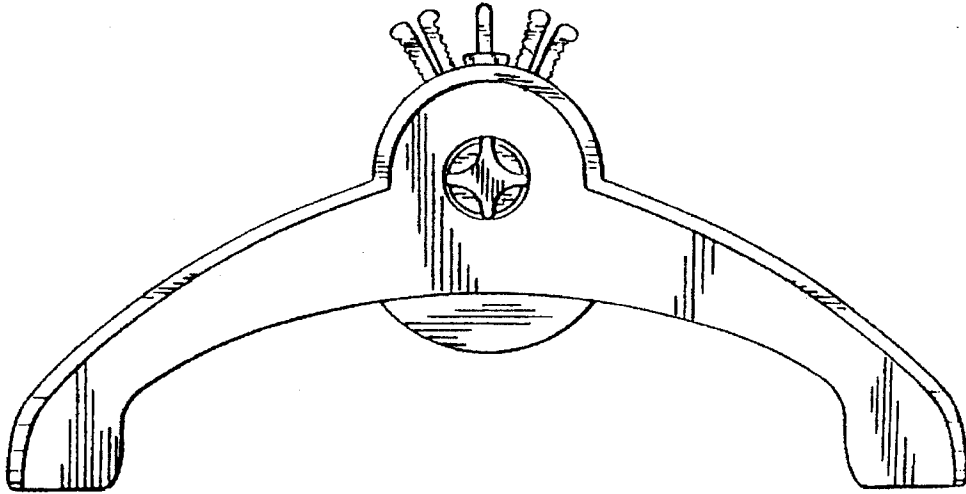

FIG. 19

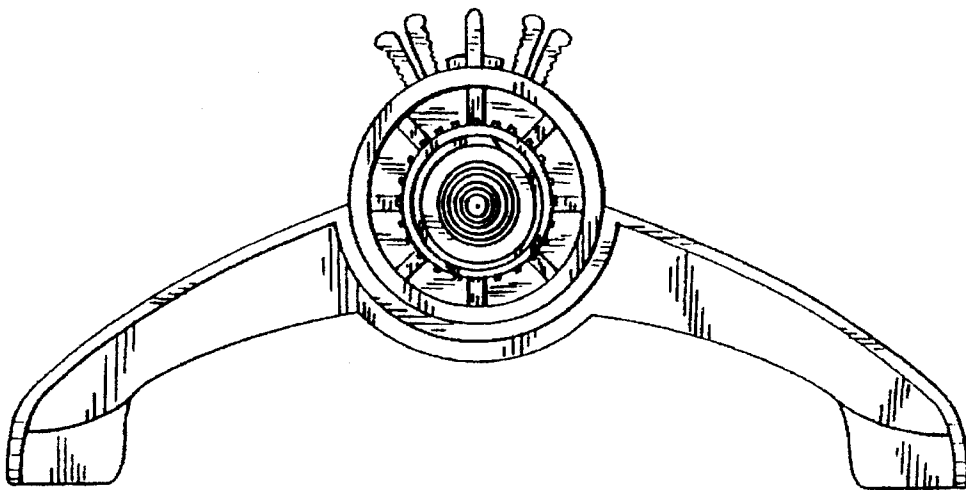

FIG. 20

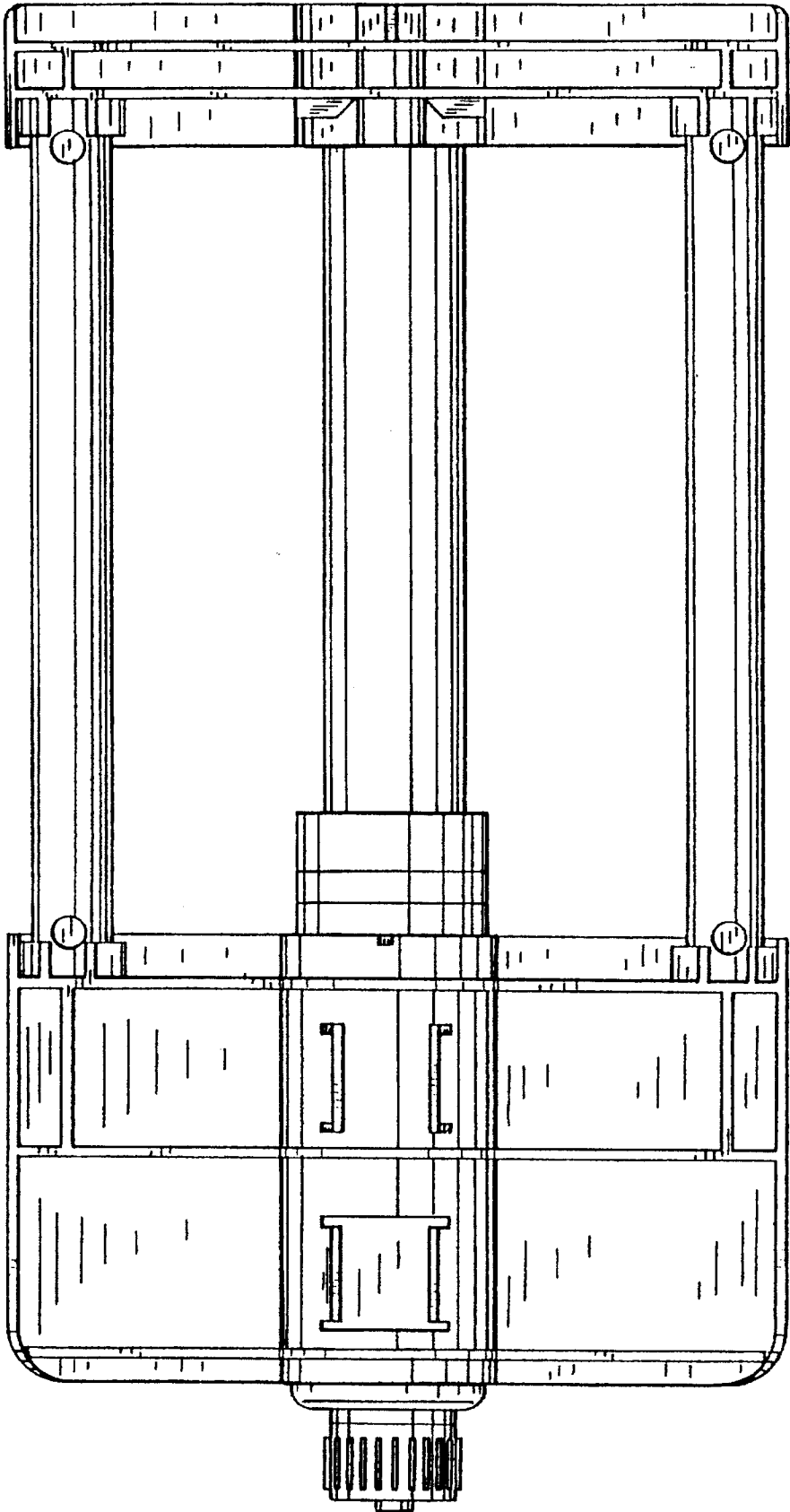

FIG. 21

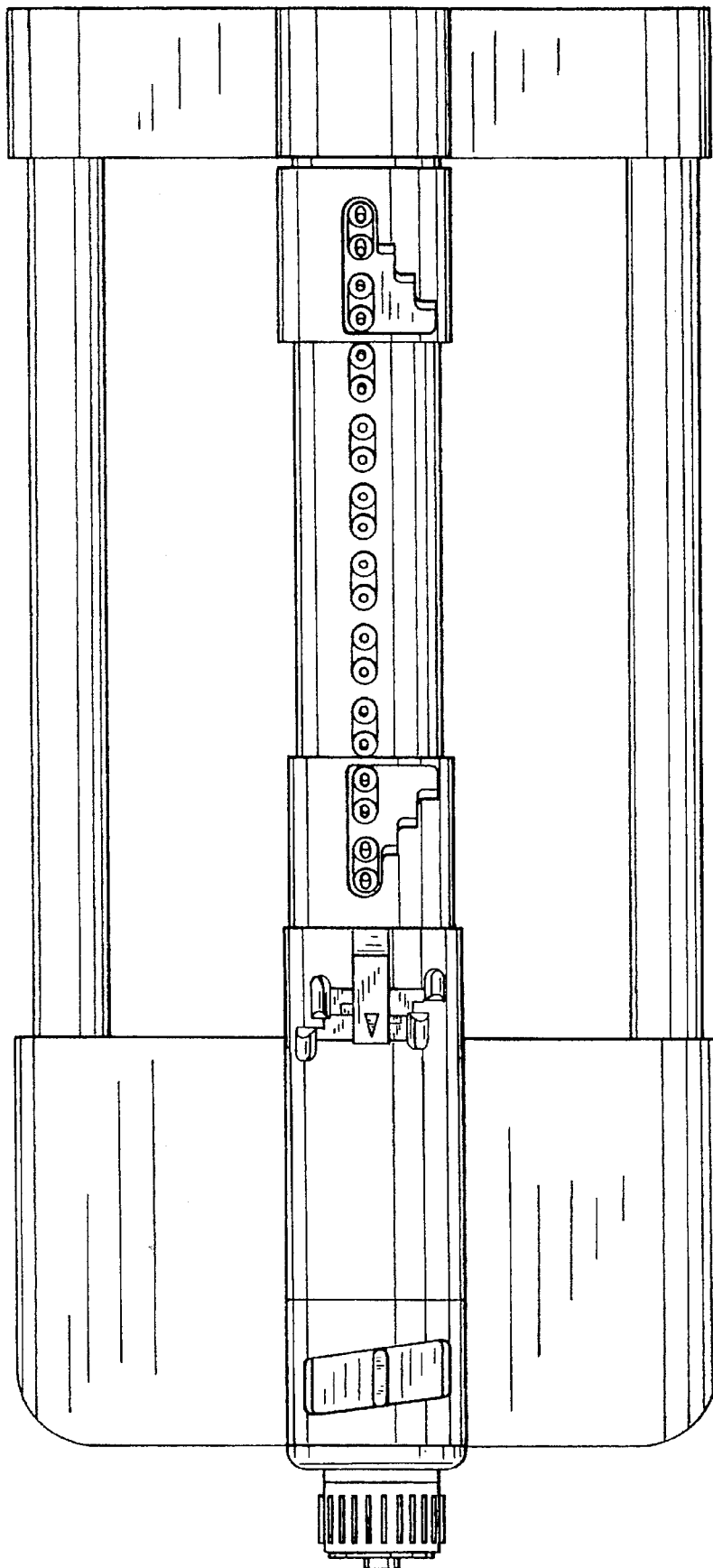

FIG. 22

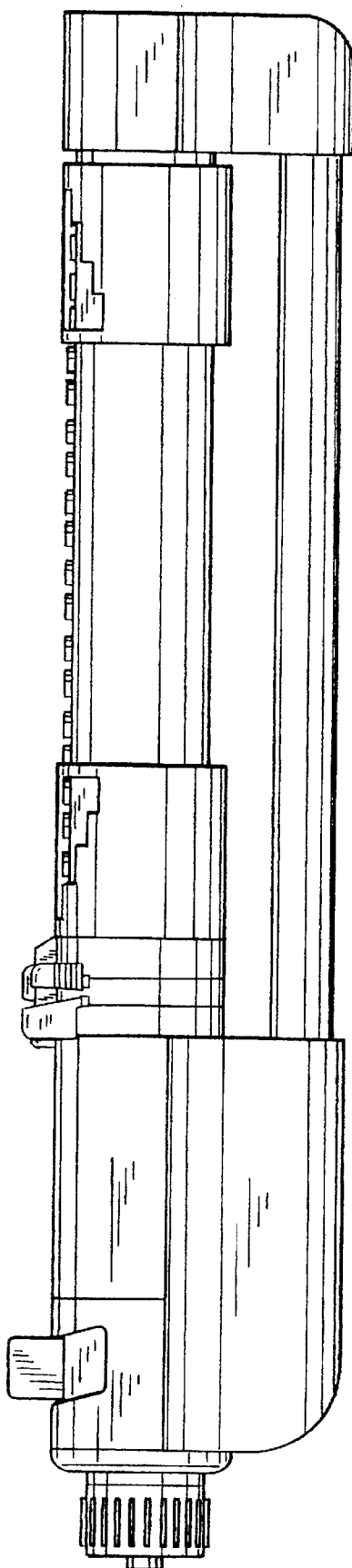

FIG. 23

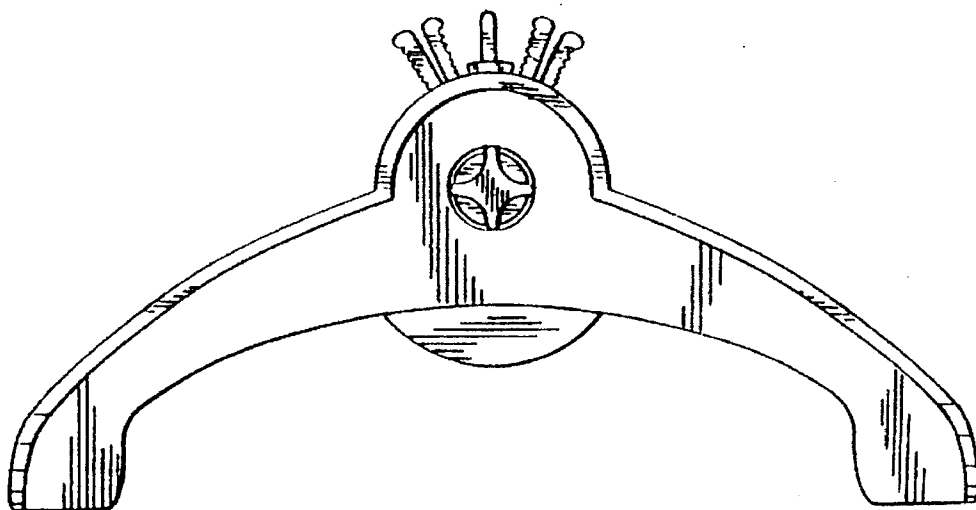

FIG. 24

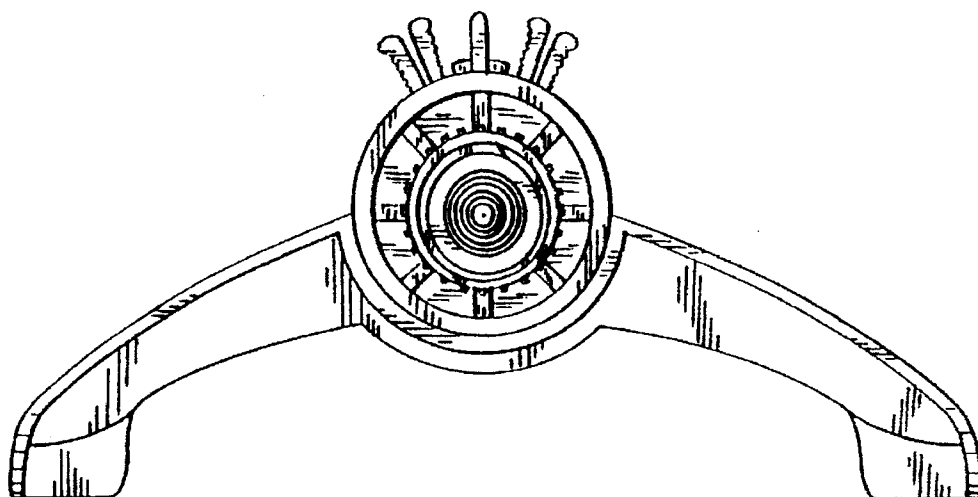

FIG. 25

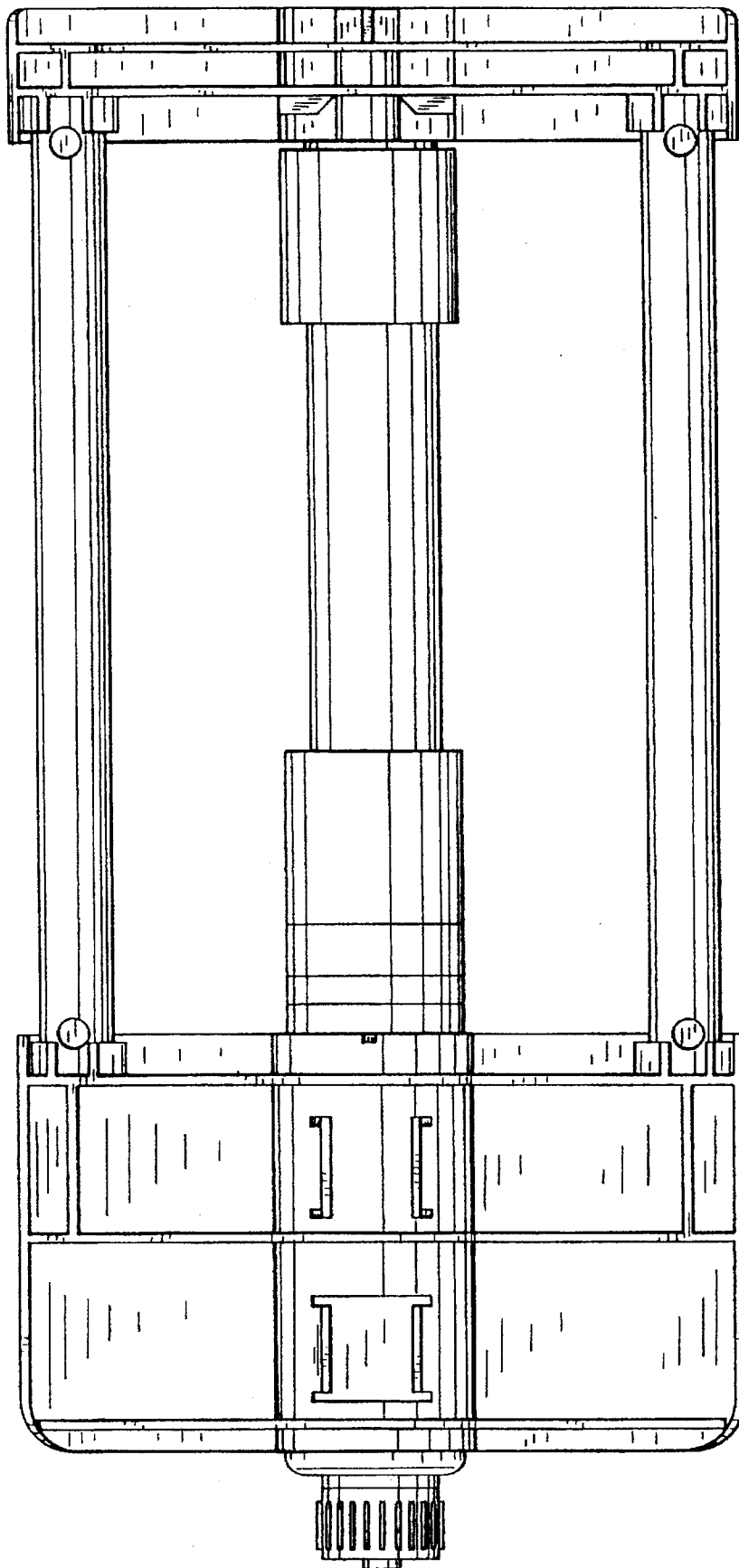

FIG. 26

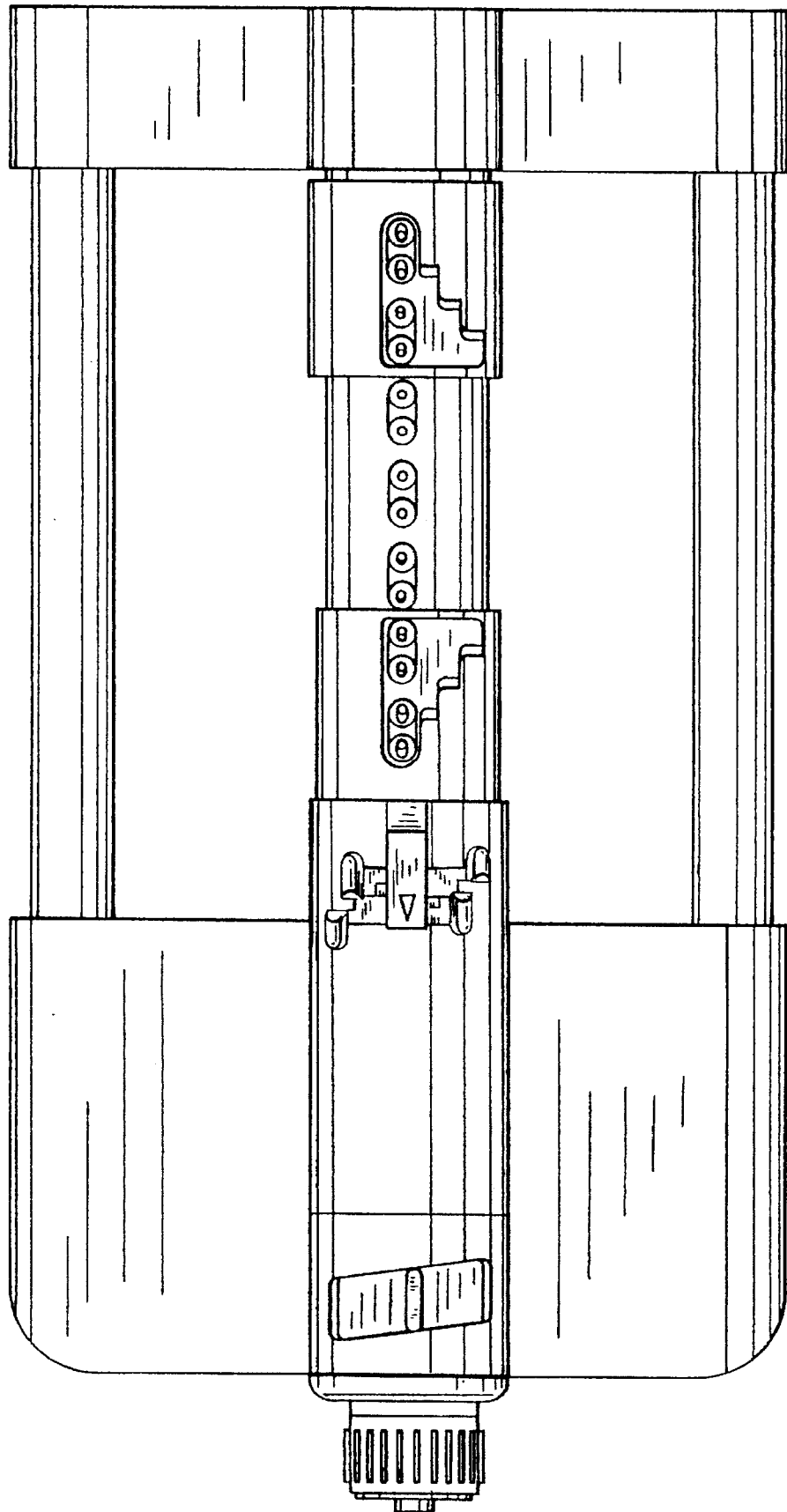

FIG. 27

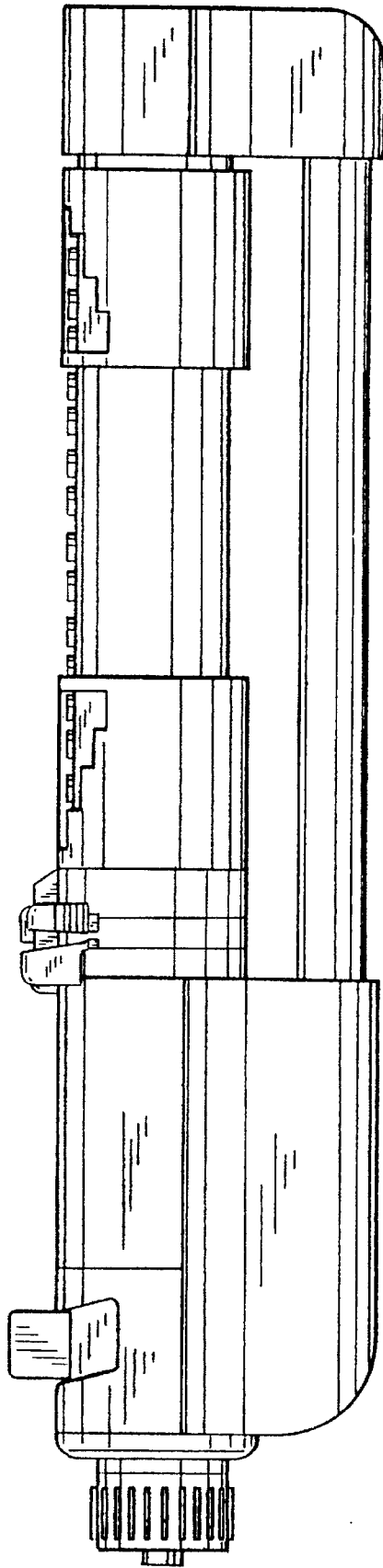



FIG. 28

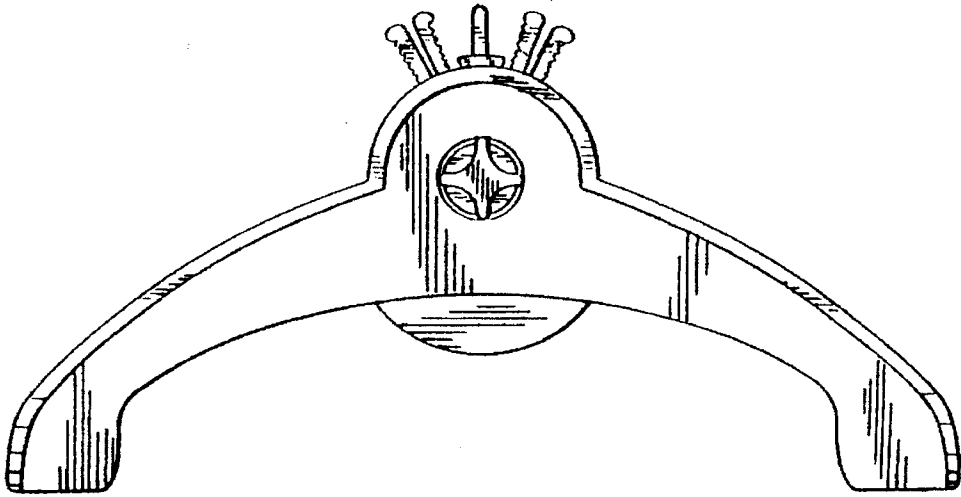

FIG. 29

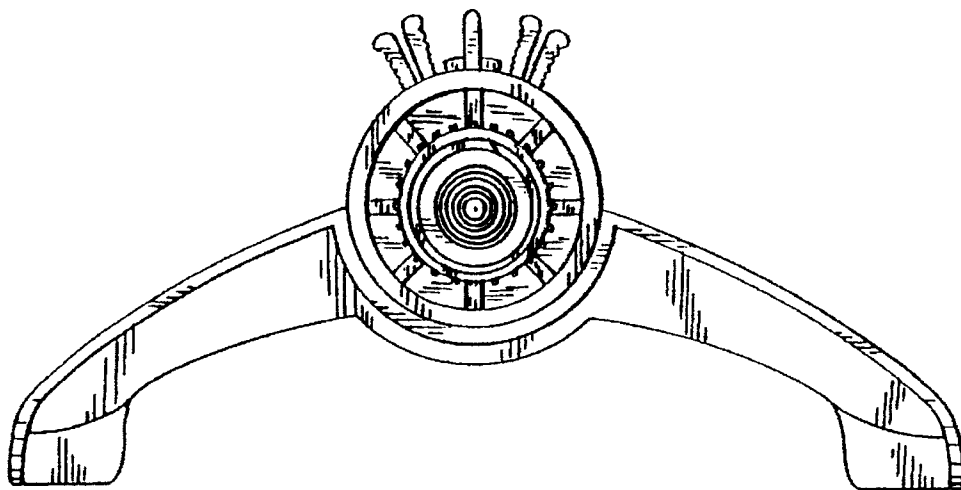

FIG. 30

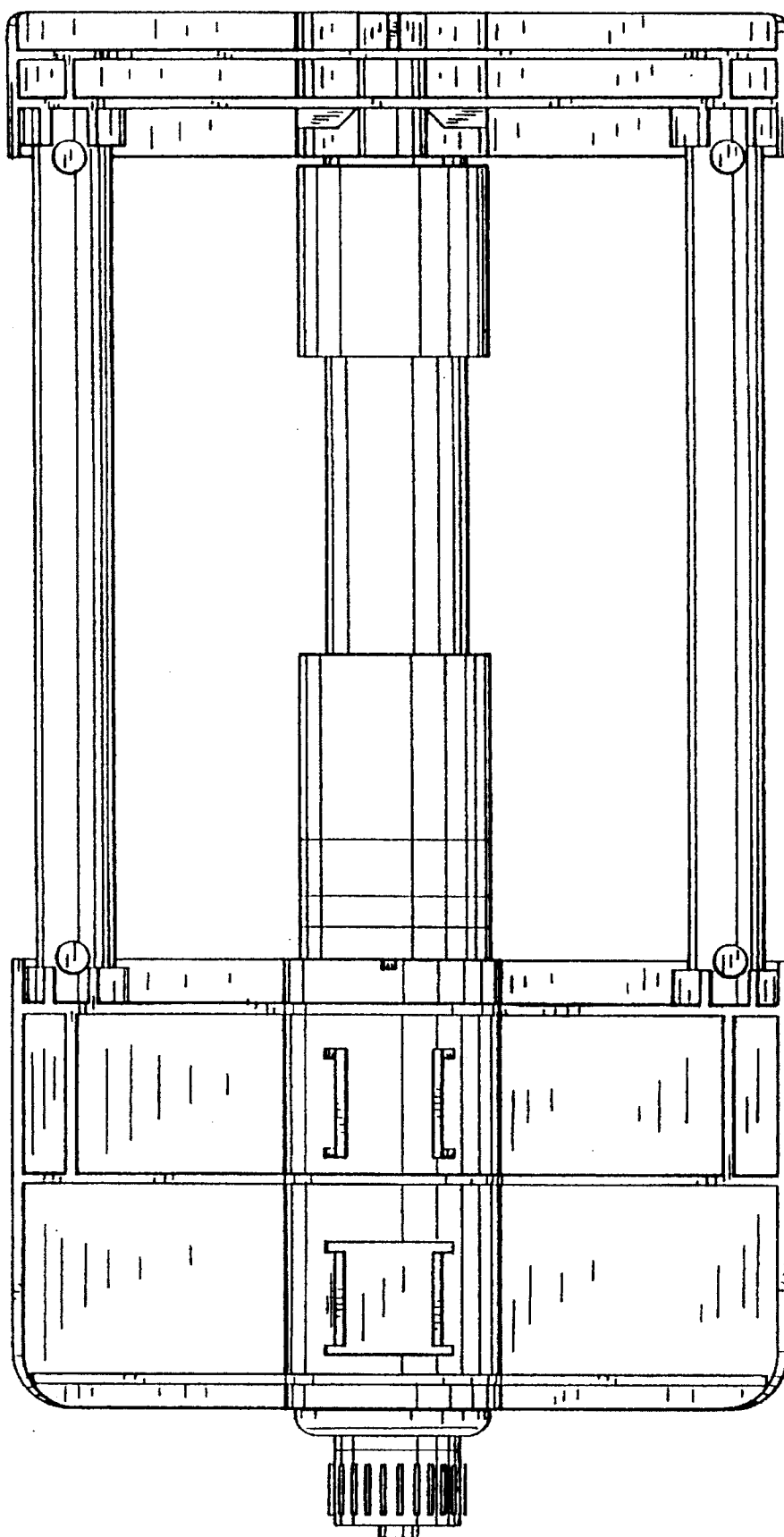

FIG. 31

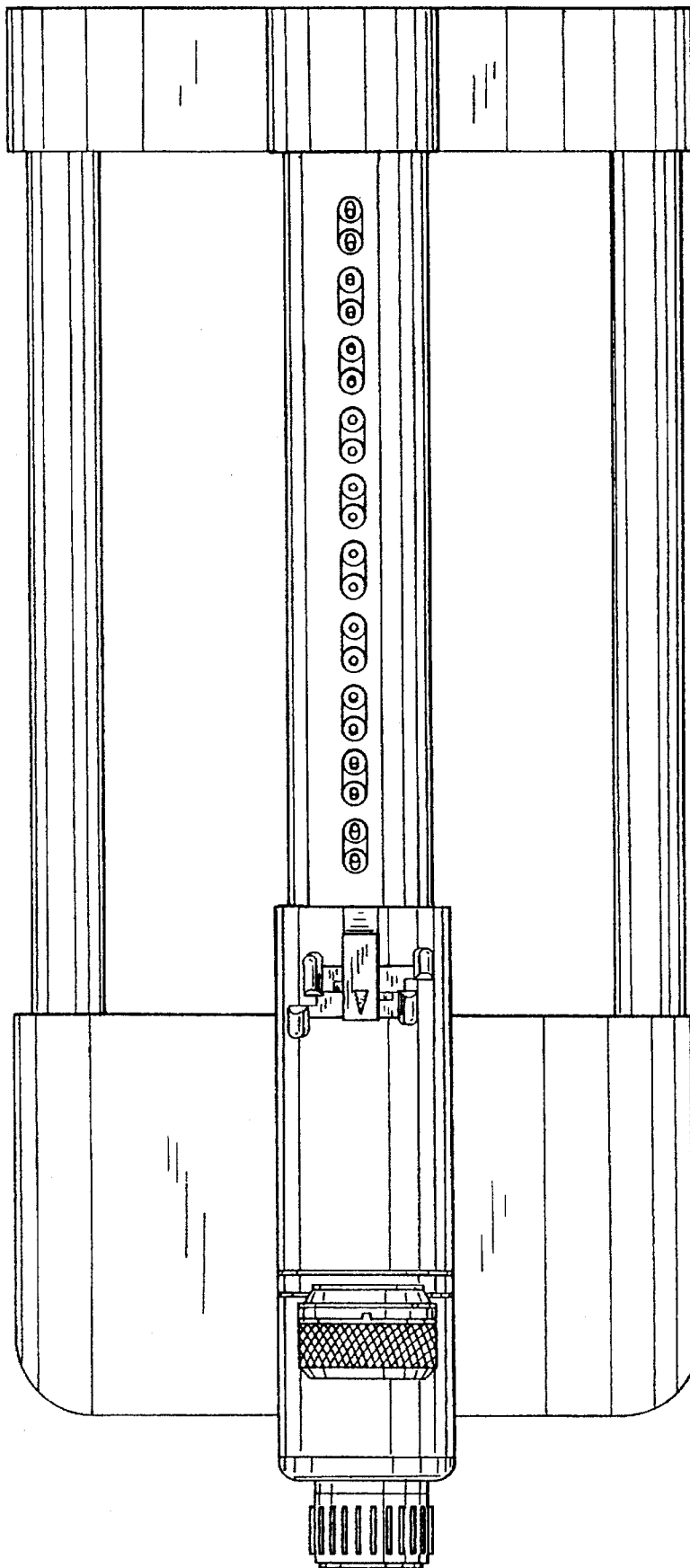

FIG. 32

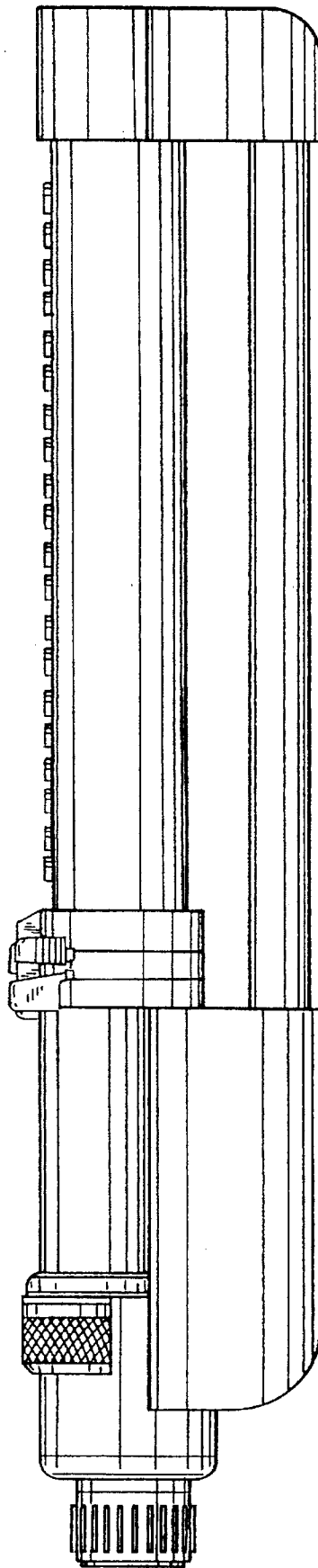

FIG. 33

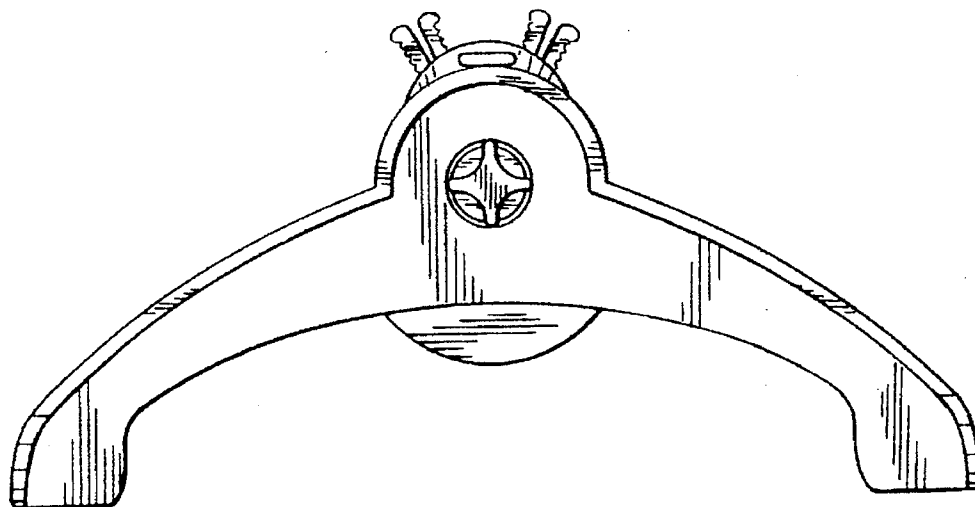

FIG. 34

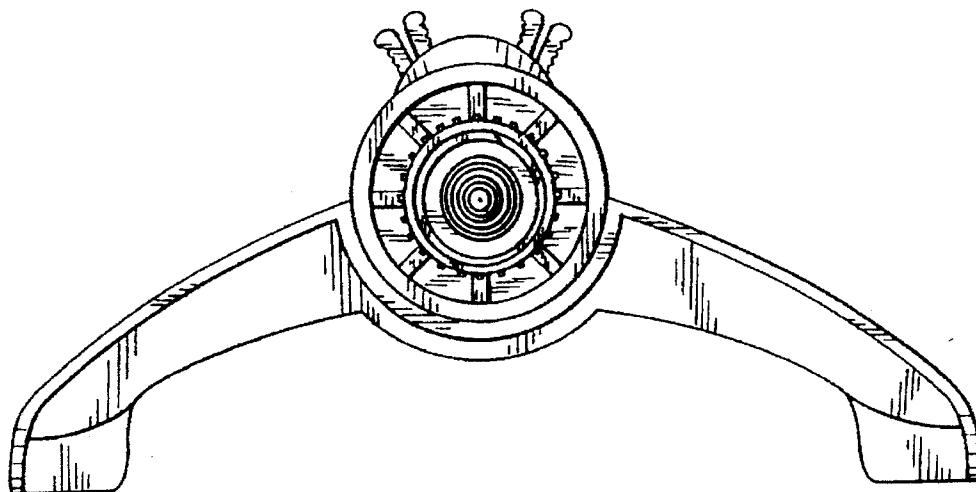

FIG. 35

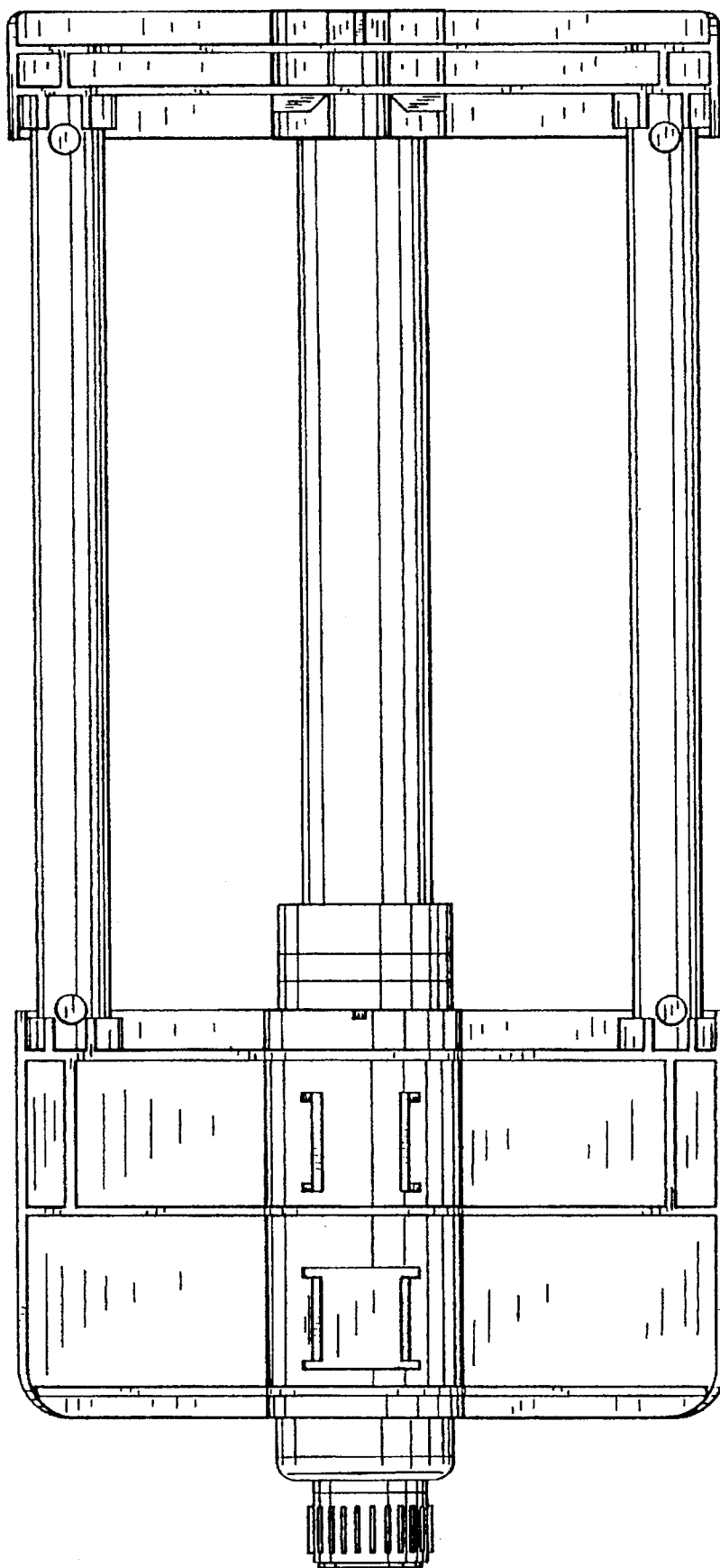

FIG. 36

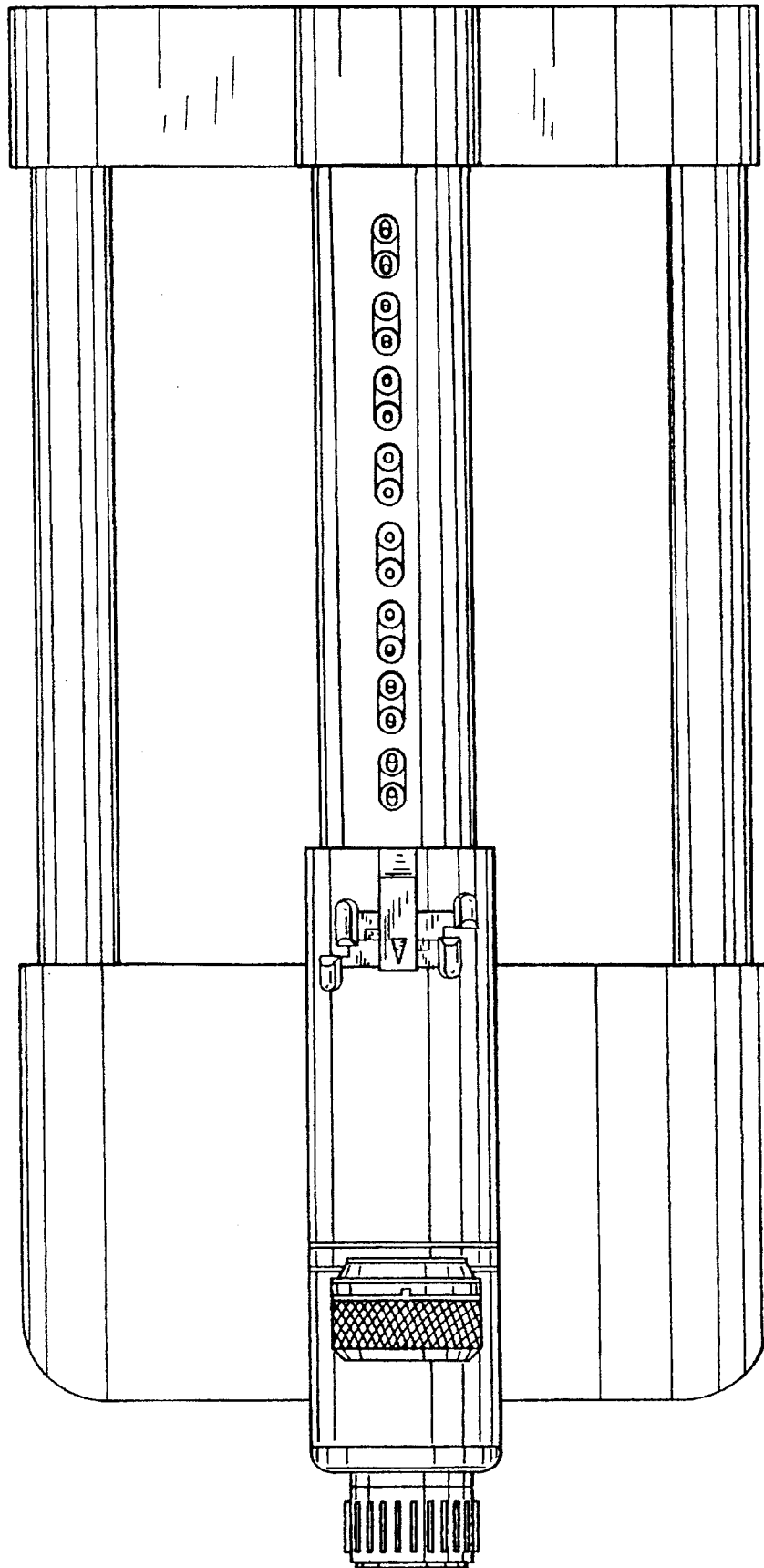

FIG. 37

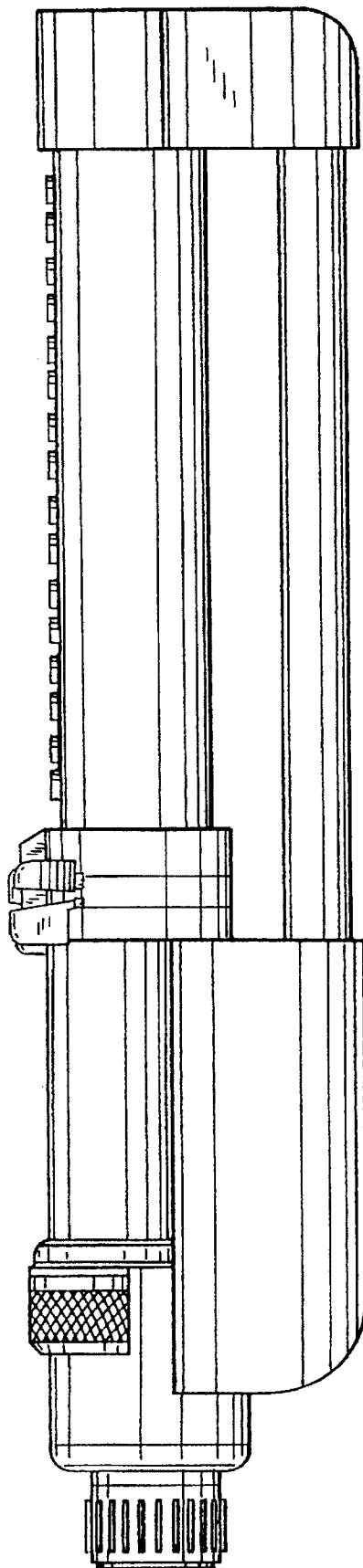



FIG. 38

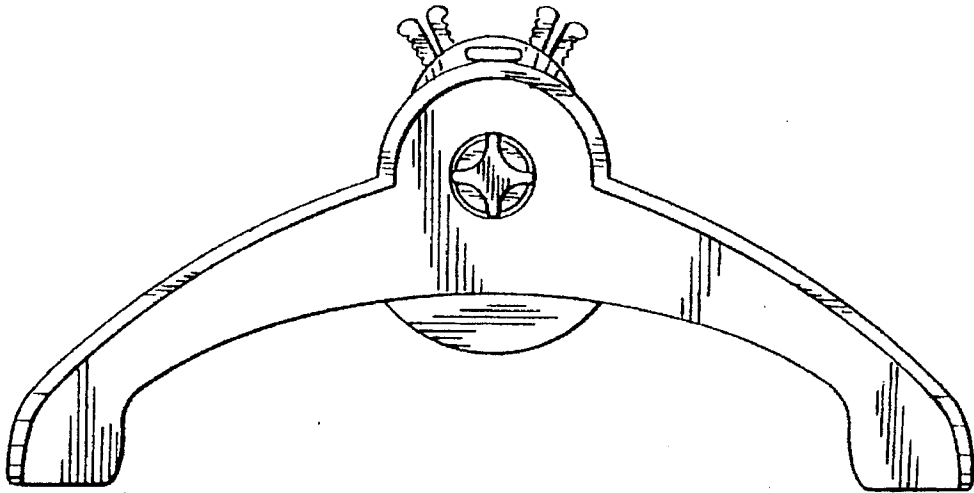

FIG. 39

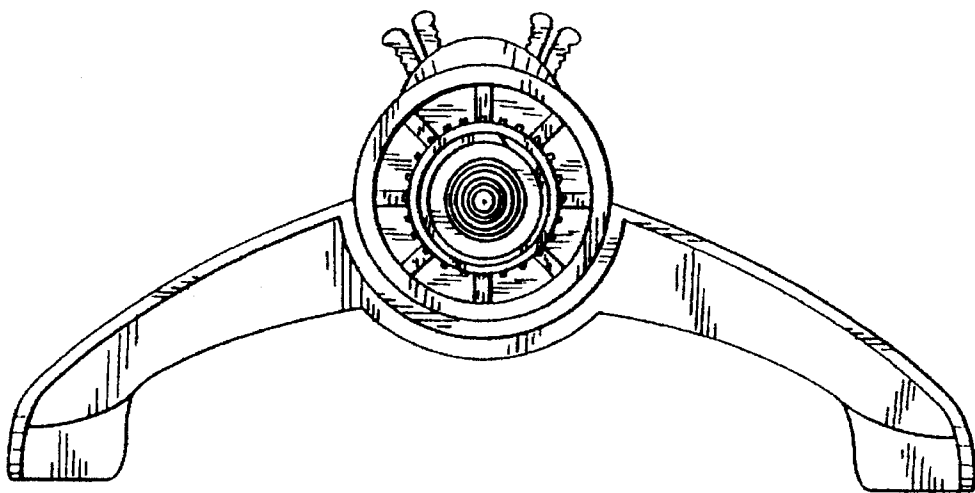

FIG. 40

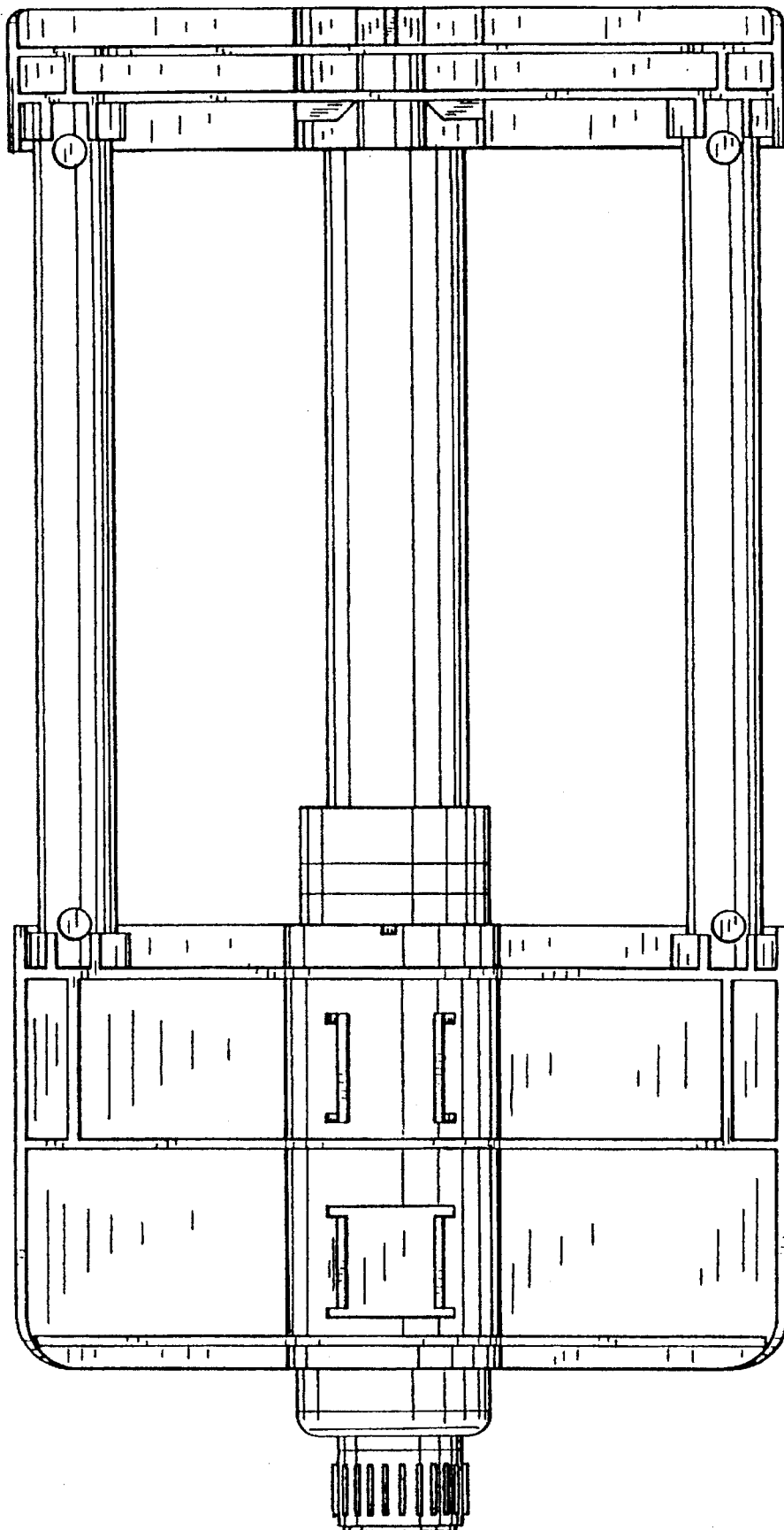

FIG. 41

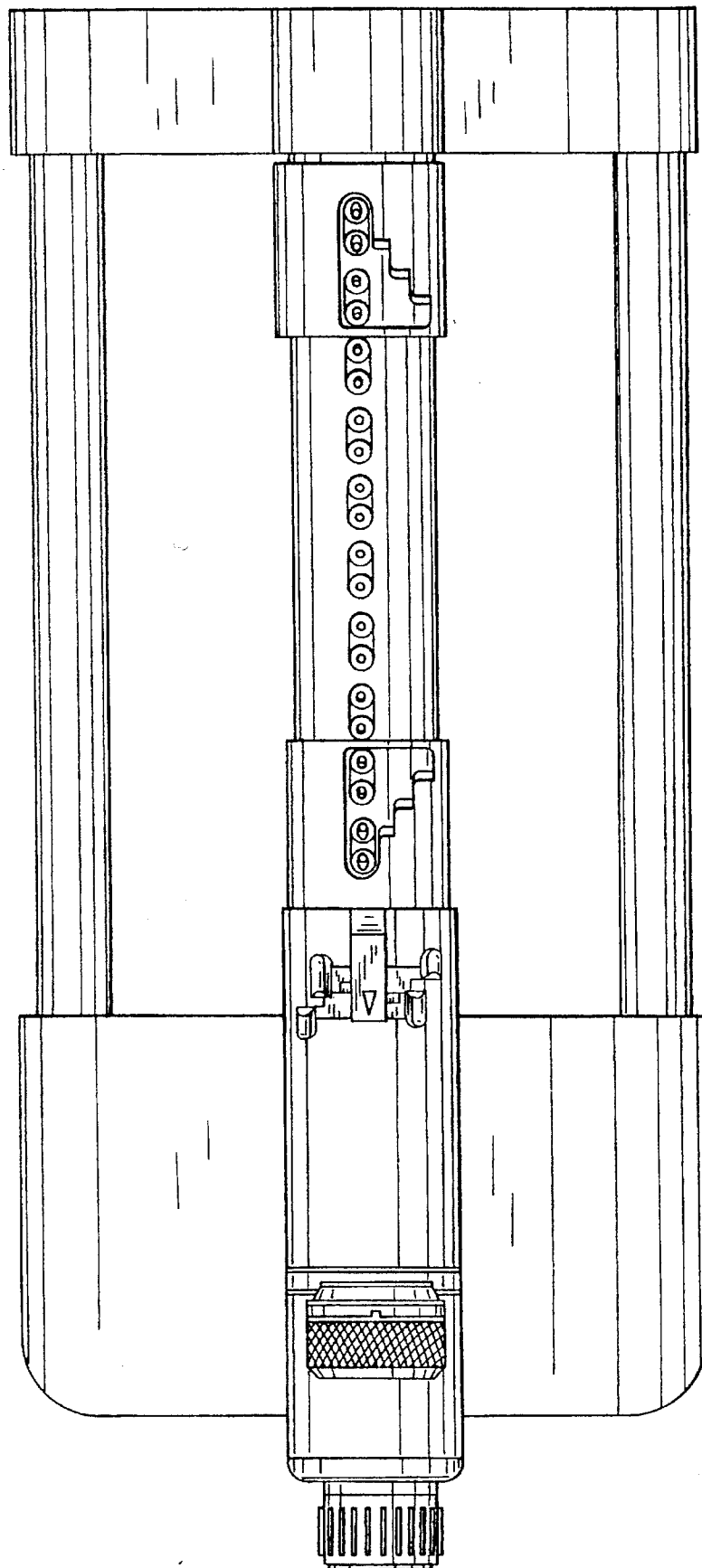

FIG. 42

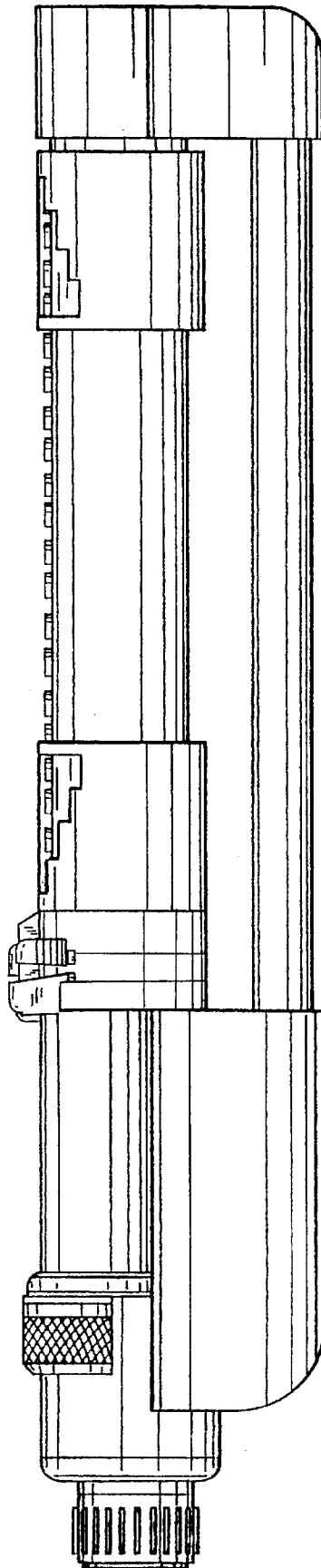

FIG. 43

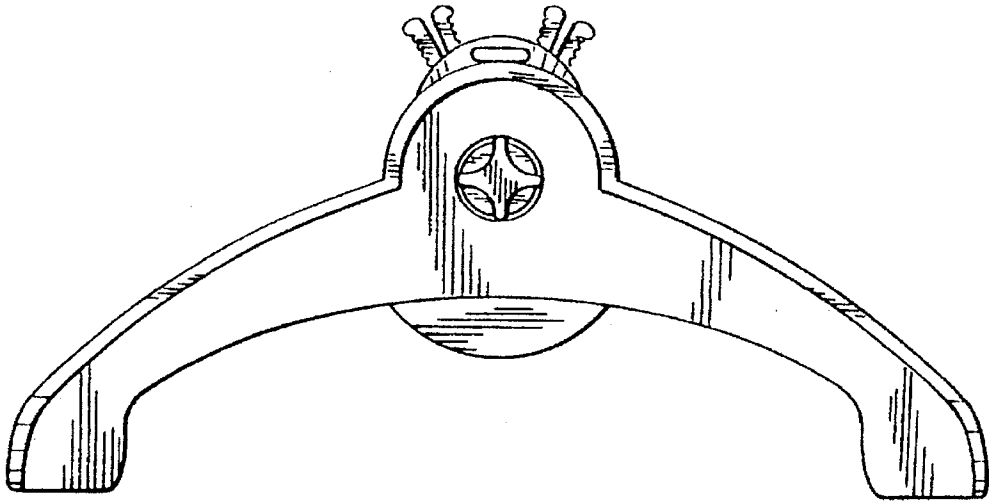

FIG. 44

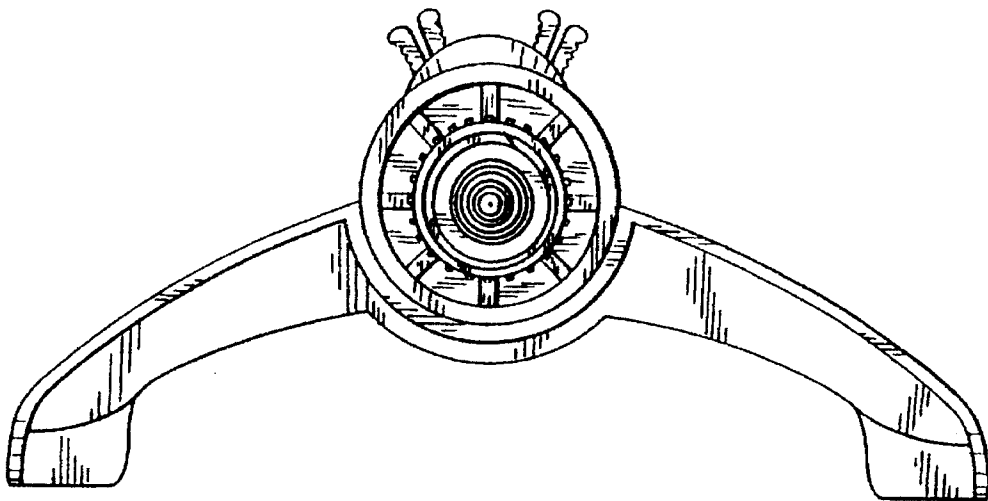

FIG. 45

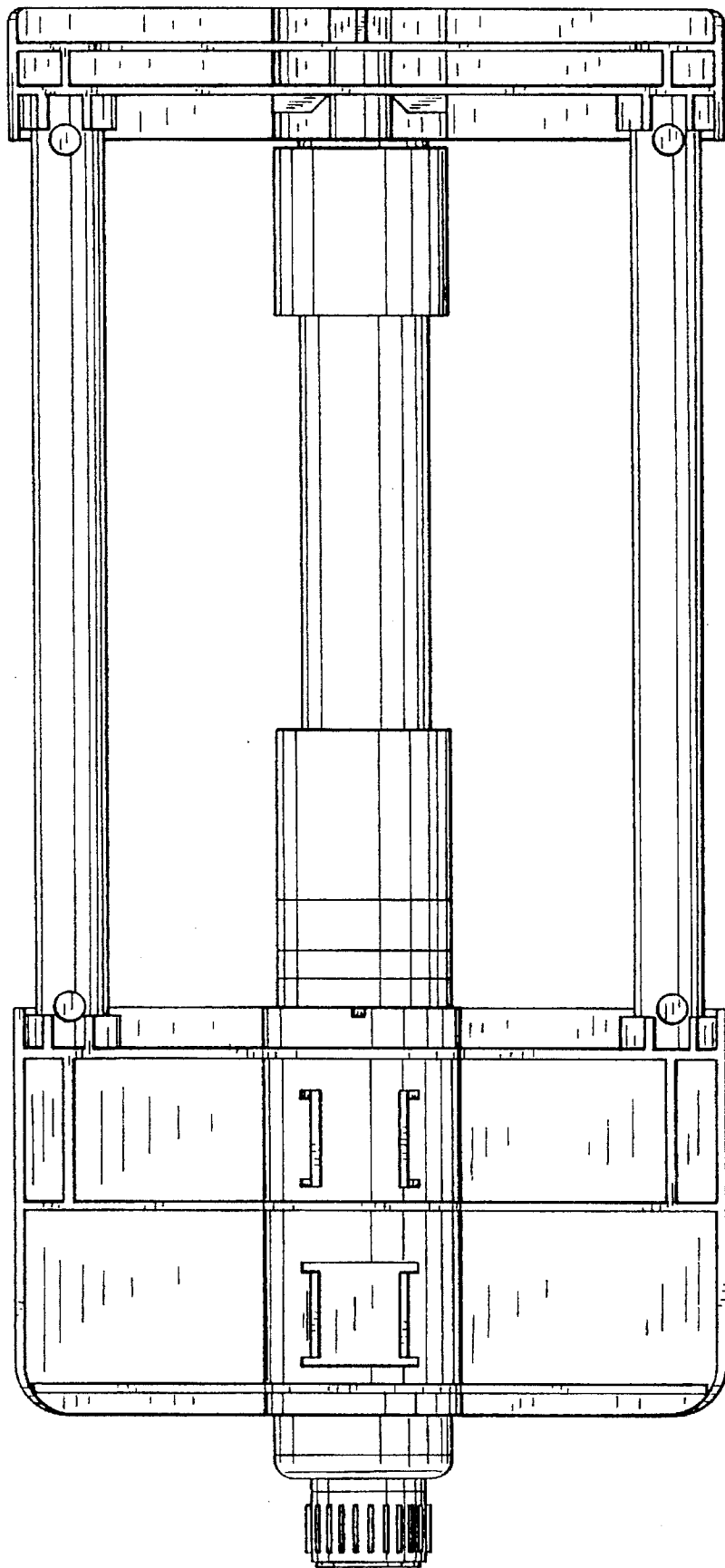

FIG. 46

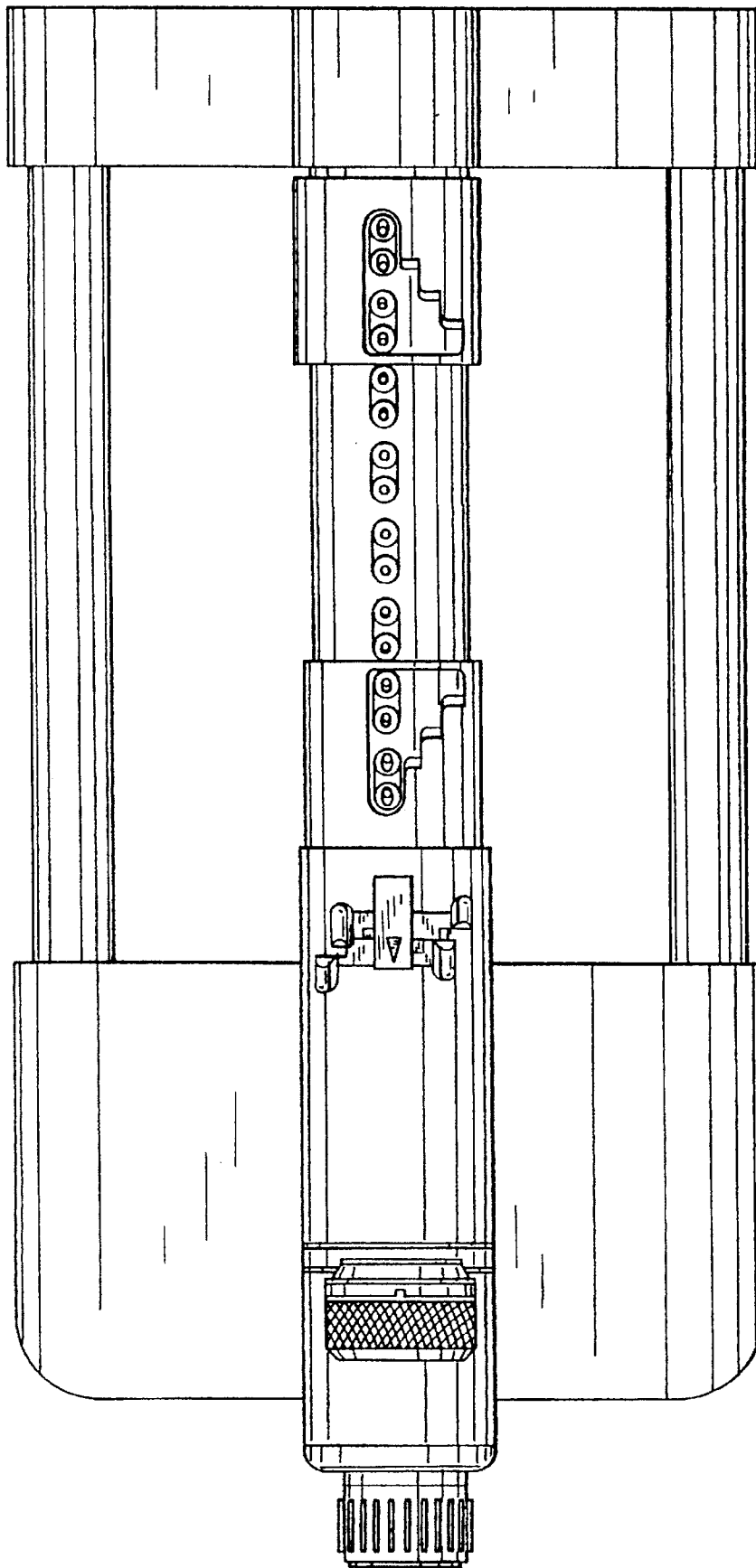

FIG. 47

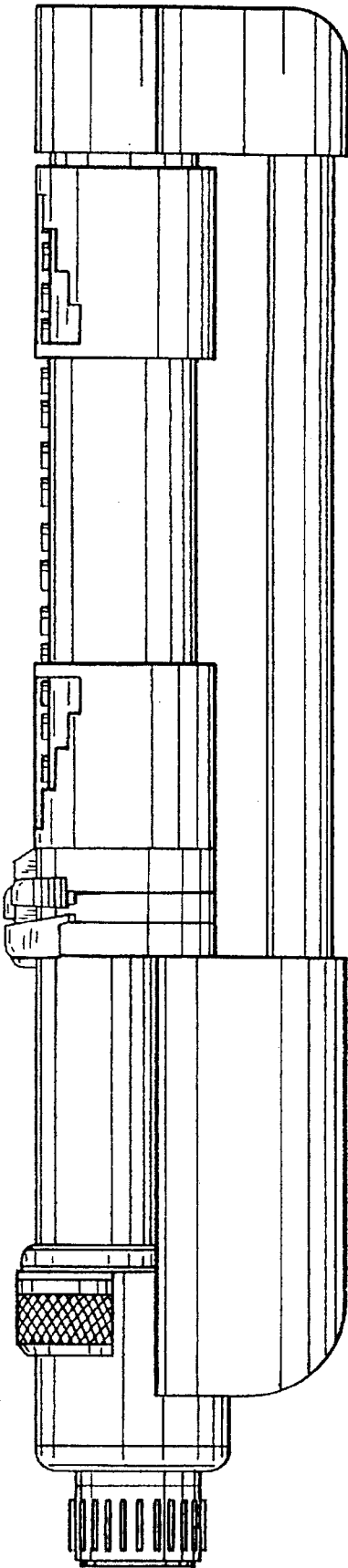



FIG. 48

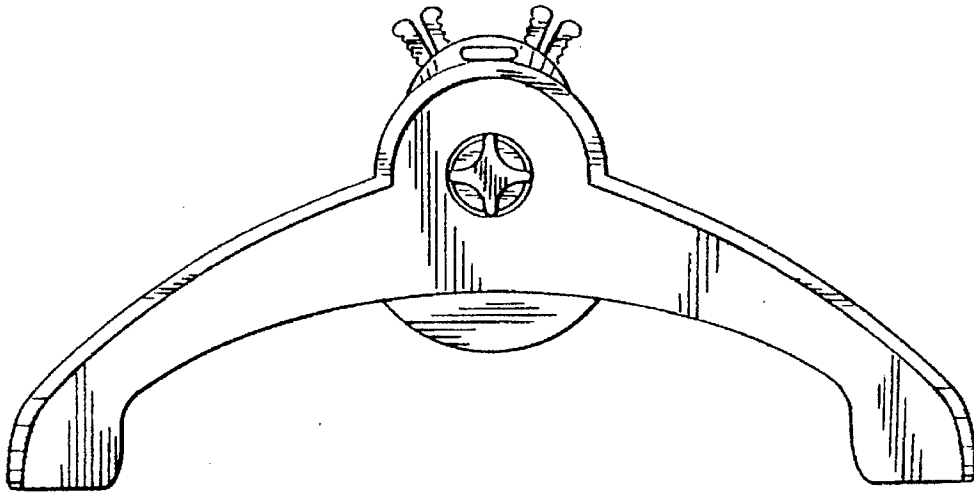

FIG. 49

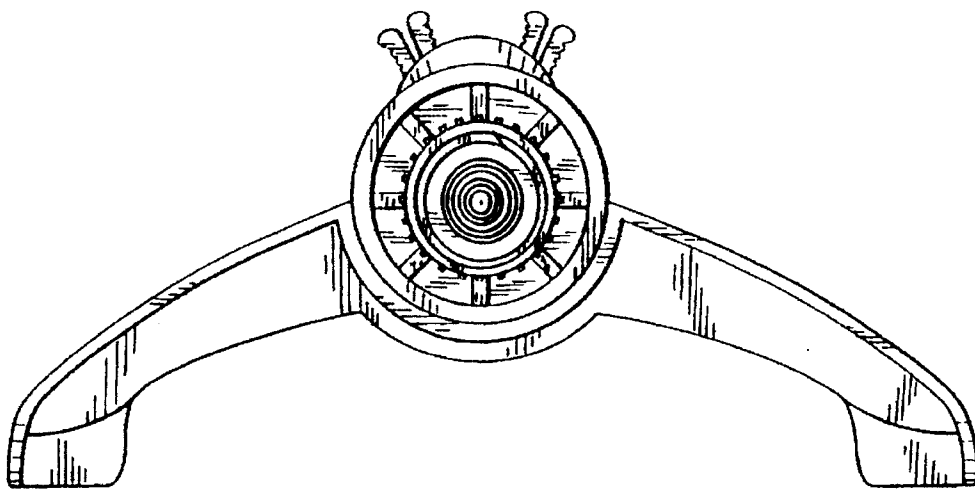

FIG. 50

