

(12) UK Patent Application

(19) GB

(11) 2 222 399 (13) A

(43) Date of A publication 07.03.1990

(21) Application No 8820525.7

(22) Date of filing 31.08.1988

(71) Applicant
Mauser-Werke GmbH

(Incorporated in the Federal Republic of Germany)

Schildgesstrasse 71-163, Postfach 16 20, 5040 Bruhl,
Federal Republic of Germany

(72) Inventor
Theo Hammes

(74) Agent and/or Address for Service
Marks & Clerk
57-60 Lincoln's Inn Fields, London, WC2A 3LS,
United Kingdom

(51) INT CL⁴
B65D 51/18

(52) UK CL (Edition J)
B8T TTB T120C T13A

(56) Documents cited
GB 0571986 A

(58) Field of search
UK CL (Edition J) B8T TCM THMS TTB
INT CL⁴ B65D
Derwent WPI, WPIL on-line

(54) A closure for a container

(57) A closure (e.g. a bung for a barrel) comprises a threaded stopper (2) screwable into the neck (1) of a container (11) and a sealing cap (3). The cap has a depending annular flange (7) with detent means (8) engageable with a snap-fit with a peripheral flange (10) of the stopper so that the stopper cannot be removed without tearing or destroying the cap. The cap has a tear-off strip (6) and breaking points (9). The stopper is provided with two key cams (not shown) for engagement by a key for unscrewing.

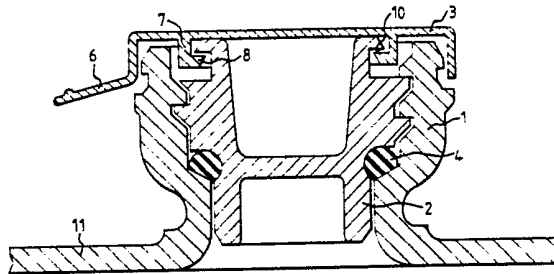

FIG. 1.

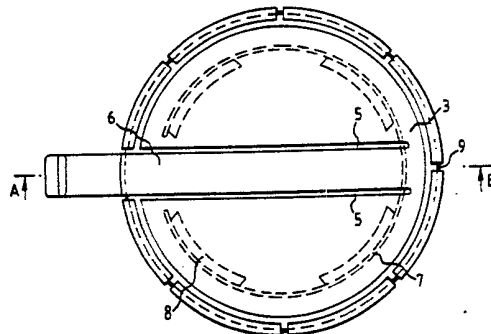

FIG. 2

GB 2 222 399 A

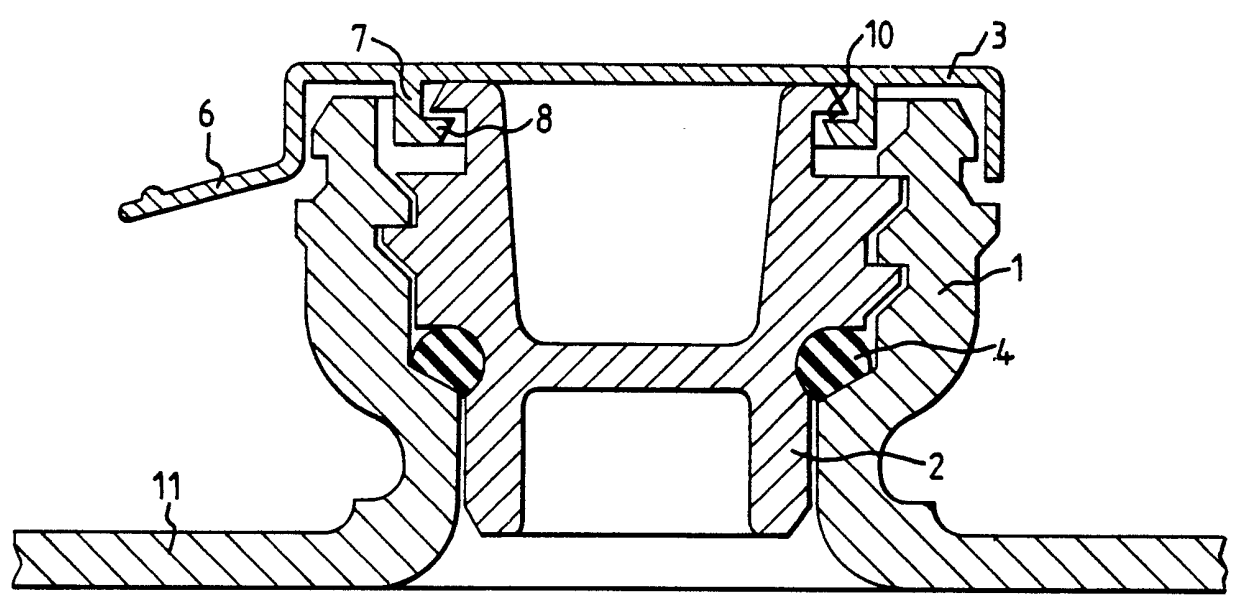

FIG. 1.

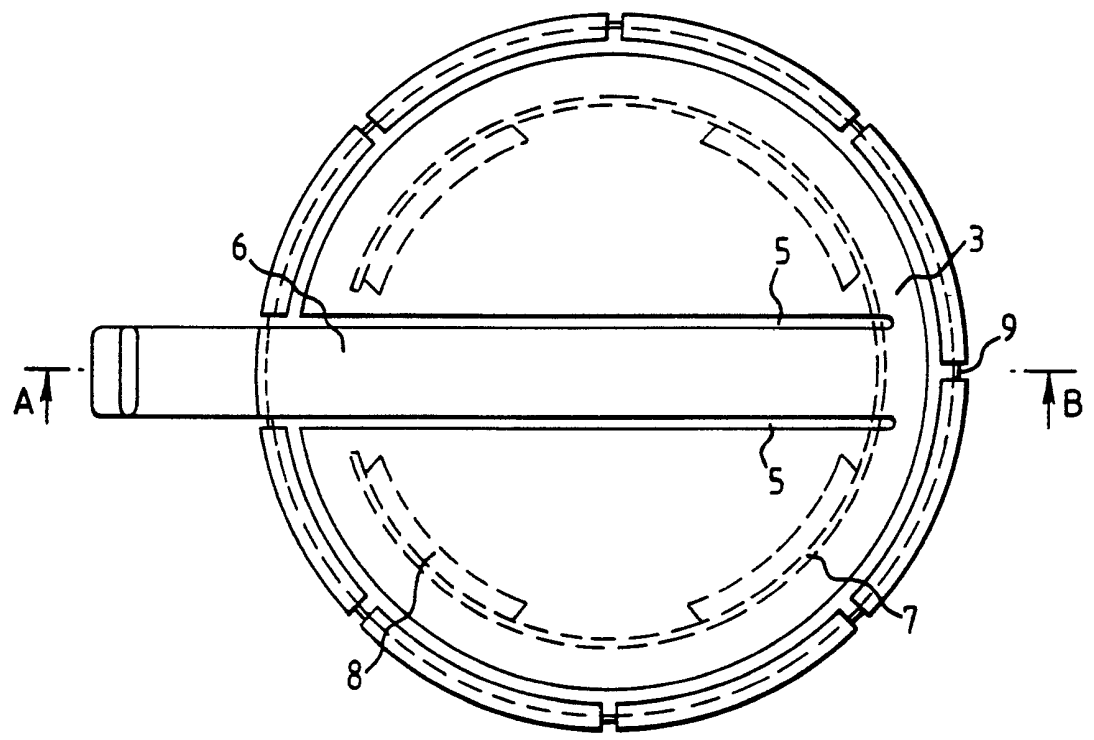

FIG. 2.

A closure for a container

The present invention relates to a closure for a container. Closures for containers are known consisting of a hollow stopper which can be screwed into the opening of a container neck. In the closed position, the stopper is sealed against a gasket in the neck of the container, the stopper and the opening neck being covered by a snap-on sealing cap.

Closures such as these are used particularly for bung barrels and are intended to indicate clearly when the barrel has been tampered with, or opened without authorisation to remove the contents of the barrel. These closures normally consist of a screw cap and a securing ring, which is destroyed during initial unscrewing, the screw cap and the securing ring consisting of separate parts. Preset breaking points are evenly arranged over the periphery of the securing ring, which, when the screw cap is being screwed on, are broken open at the same time. This can however give rise to so much play that the securing ring can expand sufficiently without the individual ring parts actually springing off. The fastening of the securing ring is maintained, therefore the cohesive ring parts can be

pressed together after closure has taken place again. This makes it almost impossible to indicate reliably whether any unauthorised opening of the container has taken place.

In the case of heavy-duty closures, for example bung closures of high-capacity barrels, the bungs have to be closed by using a key to apply the necessary torque. The bungs are screwed into bung holes with an inner thread, and at the same time pressed firmly against the gasket.

To create a security arrangement for these bungs, which are customary in the trade, without having to make alterations to the bung itself or to the barrel, two half-shells are moulded onto the underside of the seal cap and project into the bung hollow between the key stops. When the seal cap is snapped on, these half-shells engage, with engagement projections arranged at their lower end, behind corresponding undercuts in the side wall of the bung hollow.

This type of security arrangement of the bung has various disadvantages, on the one hand because manufacture is complicated and on the other because the seal cap has to be directed towards the key cams.

An object of the present invention is to provide a closure which enables the above-mentioned disadvantages to be overcome.

The invention provides a closure as claimed in claim 1.

Thus, to open the seal cap it must be destroyed, so as to make unauthorised opening clearly visible. Closing and/or imposing of the seal cap can be done in any desired rotational position without having to take account of the key stops.

The outer edge the seal cap grips over the neck opening, thus preventing introduction of a tool for unauthorised levering-up of the seal cap.

An embodiment of the invention will now be described by way of example with reference to the accompanying drawing, wherein:

Fig. 1 is a longitudinal section of a closure taken along section line A-B of Fig. 2, and

Fig. 2 is a plan view of the sealing cap of Fig. 1.

In the drawing, a bung 2, constructed as a hollow stopper, is screwed into a neck 1 of a container 11 and

in the closed position rests in a sealing manner against a gasket 4 mounted inside the neck 1. Two keys (not shown) are arranged in part of the stopper which is open towards the outside. A sealing cap 3, with a depending annular flange 7 on the underside, is forced onto the stopper. Detent means in the form of inwardly-extending detents 8 are provided on the inner periphery of the flange 7 and, when the sealing cap 3 is in place, engage with a snap-fit under a peripheral flange 10 of the stopper 2.

As can be seen in Fig. 2, preset breaking points or weakening notches 9 are provided on the outer edge of the sealing cap 3, and a tear-open flap 6 is arranged between weakening grooves 5. The stopper cannot be accessed until the tear-open-flap 6 is removed, and this is clearly visible.

Claims:

1. A closure for a container comprising a hollow stopper which can be screwed into a container neck, and a sealing cap, wherein the underside of the sealing cap has a depending annular flange with detent means engageable with a snap-fit in use with a peripheral flange of the stopper so that the stopper cannot be removed without tearing or destroying the sealing cap.
2. A closure as claimed in claim 1, wherein the sealing cap has a tear-off strip which must first be torn off before the cap can be removed to allow access to the stopper.
3. A closure substantially as herein described with reference to the accompanying drawing.
4. A container having a neck closed with a closure as claimed in any one of the preceding claims.