



(86) Date de dépôt PCT/PCT Filing Date: 2019/02/01
 (87) Date publication PCT/PCT Publication Date: 2019/08/15
 (45) Date de délivrance/Issue Date: 2023/04/11
 (85) Entrée phase nationale/National Entry: 2020/08/07
 (86) N° demande PCT/PCT Application No.: EP 2019/052509
 (87) N° publication PCT/PCT Publication No.: 2019/154732
 (30) Priorité/Priority: 2018/02/06 (EP18382064.6)

(51) Cl.Int./Int.Cl. *C01B 3/34* (2006.01),
C01B 3/24 (2006.01), *C01B 32/05* (2017.01)

(72) Inventeurs/Inventors:
 ABANADES VELASCO, ALBERTO, ES;
 MUNOZ ANTON, JAVIER, ES;
 MARTINEZ-VAL PENALOSA, JOSE MARIA, ES;
 GEISSLER, TOBIAS, DE;
 STOPPEL, LEONID, DE;
 ...

(73) Propriétaires/Owners:
 UNIVERSIDAD POLITECNICA DE MADRID, ES;
 KARLSRUHER INSTITUT FUER TECHNOLOGIE, DE

(74) Agent: BRUNET & CO.

(54) Titre : PROCÉDE ET DISPOSITIF DE DECOMPOSITION THERMIQUE DIRECTE D'HYDROCARBURES AVEC DU METAL LIQUIDE EN L'ABSENCE D'OXYGENE POUR LA PRODUCTION D'HYDROGENE ET DE CARBONE
 (54) Title: PROCESS AND DEVICE FOR DIRECT THERMAL DECOMPOSITION OF HYDROCARBONS WITH LIQUID METAL IN THE ABSENCE OF OXYGEN FOR THE PRODUCTION OF HYDROGEN AND CARBON

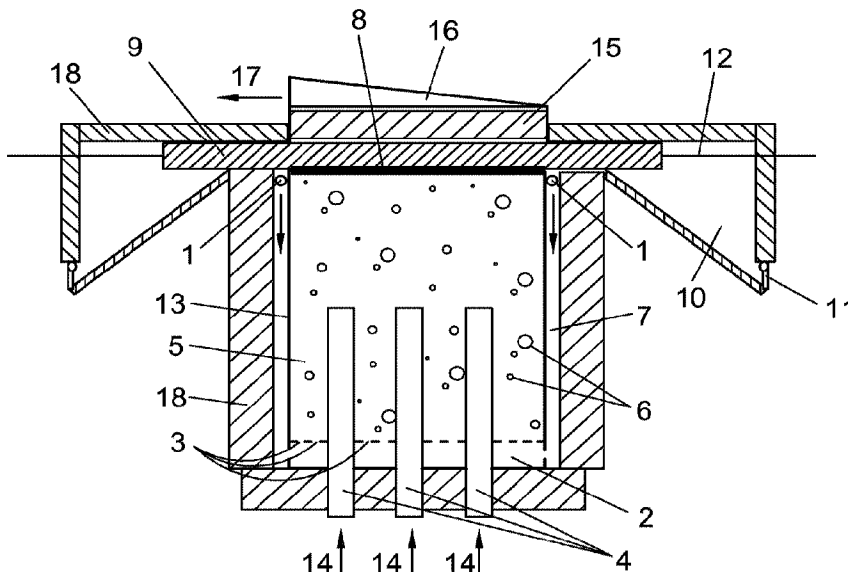

(57) **Abrégé/Abstract:**

The invention refers to a process and the device for the direct thermal decomposition of hydrocarbons into solid carbon and hydrogen comprising: preheating a hydrocarbon gas stream to a temperature between 500 and 700°C; injecting the pre-heated

(72) **Inventeurs(suite)/Inventors(continued):** DIETRICH, BENJAMIN, DE; PLEVAN, MICHAEL, DE; WETZEL, THOMAS, DE

(57) **Abrégé(suite)/Abstract(continued):**

hydrocarbon gas stream into the reactor pool of a liquid metal reactor containing a liquid media; forming a multi-phase flow with a hydrocarbon gas comprising hydrogen and solid carbon at a temperature between 900 and 1200°C; forming a carbon layer on the free surface of the liquid media made up of solid carbon particles which are then displaced into at least one carbon extraction system and at least one recipient for collecting them; at the same time, the gas comprising hydrogen leaves the reactor pool through a porous rigid section, being collected at a gas outlet collector from where the gas comprising hydrogen finally leaves the liquid metal reactor.

(12) INTERNATIONAL APPLICATION PUBLISHED UNDER THE PATENT COOPERATION TREATY (PCT)

(19) World Intellectual Property
Organization
International Bureau(43) International Publication Date
15 August 2019 (15.08.2019)(10) International Publication Number
WO 2019/154732 A1

(51) International Patent Classification:

C01B 3/34 (2006.01) *C01B 32/05* (2017.01)
C01B 3/24 (2006.01)

(21) International Application Number:

PCT/EP2019/052509

(22) International Filing Date:

01 February 2019 (01.02.2019)

(25) Filing Language:

English

(26) Publication Language:

English

(30) Priority Data:

18382064.6 06 February 2018 (06.02.2018) EP

(71) Applicants: **UNIVERSIDAD POLITECNICA DE MADRID** [ES/ES]; Ramiro de Maeztu, 7. 3^a planta, 28040 MADRID (ES). **KARLSRUHER INSTITUT**

FÜR TECHNOLOGIE [DE/DE]; Kaiserstrasse 12, 76131 KARLSRUHE (DE).

(72) Inventors: **ABÁNADES VELASCO, Alberto**; Universidad Politécnica de Madrid, Ramiro de Maeztu, 7. 3^a planta, 28040 MADRID (ES). **MUÑOZ ANTÓN, Javier**; Universidad Politécnica de Madrid, Ramiro de Maeztu, 7. 3^a planta, 28040 MADRID (ES). **MARTÍNEZ-VAL PEÑALOSA, José María**; Universidad Politécnica de Madrid, Ramiro de Maeztu, 7. 3^a planta, 28040 MADRID (ES). **GEISLER, Tobias**; KARLSRUHER INSTITUT FÜR TECHNOLOGIE, Kaiserstrasse 12, 76131 KARLSRUHE (DE). **STOPPEL, Leonid**; KARLSRUHER INSTITUT FÜR TECHNOLOGIE, Kaiserstrasse 12, 76131 KARLSRUHE (DE). **DIETRICH, Benjamin**; KARLSRUHER INSTITUT FÜR TECHNOLOGIE, Kaiserstrasse 12, 76131 KARLSRUHE (DE). **PLEVAN, Michael**; KARLSRUHER INSTITUT FÜR

(54) Title: PROCESS AND DEVICE FOR DIRECT THERMAL DECOMPOSITION OF HYDROCARBONS WITH LIQUID METAL IN THE ABSENCE OF OXYGEN FOR THE PRODUCTION OF HYDROGEN AND CARBON

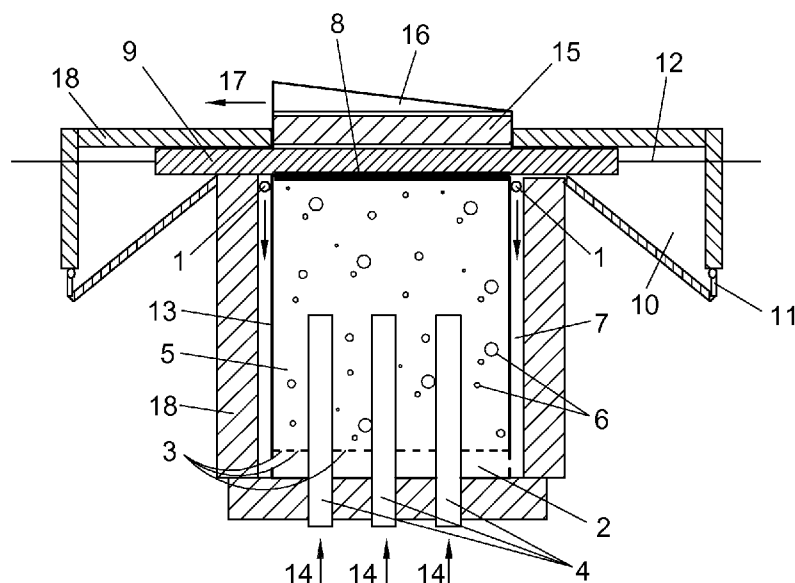

FIG. 1

(57) Abstract: The invention refers to a process and the device for the direct thermal decomposition of hydrocarbons into solid carbon and hydrogen comprising: preheating a hydrocarbon gas stream to a temperature between 500 and 700°C; injecting the pre-heated hydrocarbon gas stream into the reactor pool of a liquid metal reactor containing a liquid media; forming a multi-phase flow with a hydrocarbon gas comprising hydrogen and solid carbon at a temperature between 900 and 1200°C; forming a carbon layer on the free surface of the liquid media made up of solid carbon particles which are then displaced into at least one carbon extraction system and at least one recipient for collecting them; at the same time, the gas comprising hydrogen leaves the reactor pool through a porous rigid section, being collected at a gas outlet collector from where the gas comprising hydrogen finally leaves the liquid metal reactor.

[Continued on next page]



WO 2019/154732 A1

WO 2019/154732 A1 

TECHNOLOGIE, Kaiserstrasse 12, 76131 KARLSRUHE (DE). **WETZEL, Thomas**; KARLSRUHER INSTITUT FÜR TECHNOLOGIE, Kaiserstrasse 12, 76131 KARLSRUHE (DE).

(74) **Agent: UNGRÍA LÓPEZ, Javier**; Avda. Ramón y Cajal, 78, 28043 MADRID (ES).

(81) **Designated States** (*unless otherwise indicated, for every kind of national protection available*): AE, AG, AL, AM, AO, AT, AU, AZ, BA, BB, BG, BH, BN, BR, BW, BY, BZ, CA, CH, CL, CN, CO, CR, CU, CZ, DE, DJ, DK, DM, DO, DZ, EC, EE, EG, ES, FI, GB, GD, GE, GH, GM, GT, HN, HR, HU, ID, IL, IN, IR, IS, JO, JP, KE, KG, KH, KN, KP, KR, KW, KZ, LA, LC, LK, LR, LS, LU, LY, MA, MD, ME, MG, MK, MN, MW, MX, MY, MZ, NA, NG, NI, NO, NZ, OM, PA, PE, PG, PH, PL, PT, QA, RO, RS, RU, RW, SA, SC, SD, SE, SG, SK, SL, SM, ST, SV, SY, TH, TJ, TM, TN, TR, TT, TZ, UA, UG, US, UZ, VC, VN, ZA, ZM, ZW.

(84) **Designated States** (*unless otherwise indicated, for every kind of regional protection available*): ARIPO (BW, GH, GM, KE, LR, LS, MW, MZ, NA, RW, SD, SL, ST, SZ, TZ, UG, ZM, ZW), Eurasian (AM, AZ, BY, KG, KZ, RU, TJ, TM), European (AL, AT, BE, BG, CH, CY, CZ, DE, DK, EE, ES, FI, FR, GB, GR, HR, HU, IE, IS, IT, LT, LU, LV, MC, MK, MT, NL, NO, PL, PT, RO, RS, SE, SI, SK, SM, TR), OAPI (BF, BJ, CF, CG, CI, CM, GA, GN, GQ, GW, KM, ML, MR, NE, SN, TD, TG).

Published:

— *with international search report (Art. 21(3))*

**PROCESS AND DEVICE FOR DIRECT THERMAL DECOMPOSITION OF
HYDROCARBONS WITH LIQUID METAL IN THE ABSENCE OF OXYGEN FOR THE
PRODUCTION OF HYDROGEN AND CARBON**

5

Field of the invention

The present invention relates to the field of production of hydrogen and carbon by direct thermal decomposition of hydrocarbons. The chemical reaction is produced in a liquid metal reactor in which gas hydrocarbon is injected. The reactor and its integrated process constitute a carbon capture system with the aim of achieving a CO₂-free utilization of gaseous hydrocarbons by their conversion into hydrogen.

10

Background of the invention

Climate change is one of the pressing challenges facing our society. New technological developments should be put into practice to limit climate change. Fossil fuels such as oil, coal and natural gas will continue to play a very important role throughout this century. In particular, the consumption of natural gas is likely to increase due to consistently low prices resulting from the exploitation of unconventional reserves. Natural gas may also substitute oil in some industrial chemical processes. Finding a technological solution for continuing the utilization of fossil-fuel resources while avoiding CO₂ emissions is key to achieving the climate protection targets. Such a technology could serve as a bridging solution during the transition from a fossil-fuel based economy to a more sustainable one, making it possible to exploit available resources until a new system is completely implemented. Two major pathways in this direction are capturing the carbon content of fossil-fuels before or after their utilization. The former process is known as fossil-fuel decarbonization and the latter carbon (dioxide) capture and sequestration (CCS) and utilization (CCU).

15

20

25

The decarbonization of natural gas consists of the transformation of its components into pure solid carbon and hydrogen through a cracking/pyrolysis reaction.

For the case of methane the basic formulation is:



To develop this reaction, temperatures above 500°C are required, with energy inputs able to break the strong molecular C-H bonds (437 kJ/mol). Experimental analysis has reported that temperatures up to 1100°C reach reaction rates above 95% in thermodynamic equilibrium conditions.

30

35

The need of low-carbon processes is a must for the development of our society, either for the energy sector as for many industrial processes. Hydrogen is one of the vectors that should be metabolized to keep our system running. For instance, hydrogen is a critical feedstock for ammonia production or refineries that will need the availability
5 of a hydrogen production system free of CO₂ or for the implementation of Power-to-Gas systems. Most of the hydrogen of the world is currently produced by methane steam reforming and coal gasification, generating CO₂.

Methane decomposition into carbon and hydrogen has been studied since decades (Palmer HB, Hirt TJ. The Journal of Physical Chemistry, 67(3):709–711
10 (1963)). A number of researchers have conducted experimental and theoretical work to understand the reaction through several methods: catalytic methane cracking (A. M. Amin, et al., International Journal of Hydrogen Energy, 36, 2904 (2011); H.F. Abbas and W.M.A. Wan Daud, International Journal of Hydrogen Energy, 35, 1160 (2010)), thermal pyrolysis (S. Rodat, S. Abanades, G. Flamant, Solar Energy, 85, 645 (2011)),
15 or plasma-arch decomposition (N. Muradov, et al., Applied Catalysis A: General, 365, 292 (2009); B. Gaudernack and S. Lynam, International Journal of Hydrogen Energy, 23, 12, 1087-1093 (1998)). Results obtained from the laboratory-scale studies of methane decomposition show that high conversion rates of methane into hydrogen (with almost complete conversion of methane) are feasible at very high temperatures
20 (> 1300°C) or at comparatively lower temperatures (> 500°C) using a suitable catalyst.

Some previous patents have been also addressed to the development of hydrocarbon decomposition reactors and processes, such as US 6395197, US 6872378, US 20060130400, WO 2009145936 or US 8002854. All these previous inventions are related to catalytic, direct thermal or plasma/microwaves induced
25 methane decomposition.

The most relevant patent for methane decarburization using a molten media is US patent No. US 5767165 referred to a process for the production of methanol comprising thermally decomposing methane to produce hydrogen. In particular, claim 1 of US 5767165 describes that the methane thermal decomposition comprises: "(...)
30 *bubbling the methane through a bath comprised of a molten material operating at a temperature of at least 800°C and a pressure of 1 atm to 10 atm; cracking said methane through the use of said molten material such that elemental carbon and hydrogen gas are formed; removing the hydrogen gas from the top of the bath; and collecting the elemental carbon off the top of the liquid surface of the bath*". In said
35 patent, the methane decomposition reactor, named as MDR, is only described as the

device to carry out the process. However, there is no disclosure of the physical implementation and details of the technology. In particular, the simulation process described in said US patent shows data obtained at 800°C and 1 atm, resulting in a conversion rate corresponding to the theoretical limit of 91.9%. It has been demonstrated and published in peer-reviewed journals that this practical configuration is not realistic at a reasonable scale and that it is only achievable theoretically (M. Plevan et al., International Journal of Hydrogen Energy 40, No. 25 (2015) 8020-8033). It is likely that, at the conditions described in the claims, a very large (practically infinite) methane residence time would be required. The present invention, on the contrary, refers to a practical physical configuration that will be able to be implanted at industrial scale based on the utilization of liquid metal technology.

Other patents related to liquid metal technology applied to methane or hydrocarbon describe very different approaches from the process object of the present invention. This is the case, for example, of US patent No. US 9156017.

The present invention addresses all the technical difficulties and disadvantages of the processes described in the state of the art. In particular, it describes a new process for the production of high purity hydrogen and pure graphitic carbon, avoiding CO₂ emissions, and the reactor for carrying out said process. One of its advantages is that it will be suitable for working at an industrial scale (ton/h). Also, it allows to dramatically reduce the costs and environmental impact as compared with the processes available at the state of the art.

This is a revolutionary invention since there is no disclosure in the state of the art describing a reactor suitable for working at industrial scale transforming a hydrocarbon gas (preferably methane) into hydrogen and carbon with almost no production of CO₂.

Description of the invention

It is a first object of the invention a process for the direct thermal decomposition of hydrocarbons into solid carbon and hydrogen comprising:

- (a) preheating a hydrocarbon gas stream conducting the hydrocarbon gas stream through a conduct located surrounding the external perimeter of at least one liquid metal reactor, said conduct being located inside a thermal insulation means, from at least one hydrocarbon gas stream inlet, located at the top part of the liquid metal reactor, to the bottom part of the liquid metal reactor, obtaining a pre-heated hydrocarbon gas stream at a temperature between 500 and 700°C, and more preferably between 650 and 700°C;

- (b) injecting the pre-heated hydrocarbon gas stream obtained in step (a) into the liquid metal reactor, in particular, into a reactor pool containing a liquid media. This injection takes places at the bottom part of the liquid metal reactor, preferably through a porous section or a set of orifices distributed along the bottom part of the liquid metal reactor, injecting the hydrocarbon gas through a gas distributor into the liquid media;
- 5
- (c) once inside the reactor pool, the hydrocarbon gas moves upwards by buoyancy forming a multi-phase flow, the hydrocarbon gas being decomposed into a gas comprising hydrogen and solid carbon, at the same time that the temperature inside the reactor pool is controlled and maintained at a temperature preferably comprised between 900 and 1200°C and more preferably between 1050 and 1100°C. Preferably, this temperature will be reached by means of at least one thermal heater located inside the reactor pool or any other method suitable for inducing an homogeneous temperature in the liquid media contained inside the liquid metal reactor;
- 10
- 15
- (d) the solid carbon obtained in step (c) is accumulated at the top of the reactor pool, on the free surface of the liquid media located inside the liquid metal reactor, forming a carbon layer made up of solid carbon particles;
- (e) once the carbon layer reaches a determined thickness (preferably between 1 and 15 cm) over the free surface of the liquid metal, determined by the gas hold-up in the nominal conditions of the design, the carbon particles constituting said layer are displaced into at least one carbon extraction system consisting of a porous rigid section located at the top of the liquid metal reactor, above the free surface of the liquid media, from which they are conducted into at least one recipient for collecting the carbon particles, and preferably two recipients located at opposite sides of the liquid metal reactor. Preferably, the movement of the carbon particles towards the recipient for collecting them will be facilitated by a vibrational movement generated by a mechanical means such as a mechanical shaft. When reaching said recipient the solid carbon particles will preferably fall therein by gravity;
- 20
- 25
- 30
- (f) at the same time, the gas comprising hydrogen obtained in step (c) leaves the reactor pool through the porous rigid section, being collected at a gas outlet collector from where the gas comprising hydrogen finally leaves the liquid metal reactor.
- 35
- It is a further object of the invention the device for carrying out said process. In

particular, this device will be suitable for carrying out the direct thermal decomposition of hydrocarbons into solid carbon and hydrogen and will comprise:

- 5 (a) a conduct comprising at least one hydrocarbon gas inlet located at the top of a liquid metal reactor and at least one hydrocarbon gas outlet located at the bottom of the liquid metal reactor corresponding to the hydrocarbon gas inlet into the liquid metal reactor, and in particular into a reactor pool designed for containing a liquid media, preferably through a porous section or a set of orifices distributed along the bottom part of the liquid metal reactor and wherein said conduct is located inside a thermal insulation means;
- 10 (b) the liquid metal reactor further comprises at least one thermal heater located inside the reactor pool or any other media suitable for inducing an homogeneous temperature inside the liquid metal reactor;
- 15 (c) in addition, at the top of the liquid metal reactor, at least one carbon extraction system consisting of a porous rigid section is located, said porous rigid section being connected to at least one recipient suitable for collecting carbon particles, and preferably two recipients located at opposite sides of the liquid metal reactor. The connection between the porous rigid section and the recipient for collecting carbon particles will preferably incorporate mechanical means (such as a mechanical shaft) for facilitating the movement of the solid carbon particles;
- 20 (d) the porous rigid section also incorporates, at the top of it, a barrier designed for the carbon particle retention, wherein said barrier separates the porous rigid section from a gas outlet collector comprising at least one gas outlet.

Brief descriptions of the figures

- 25 For a better understanding of the invention, the following figures are included:
- **Figure 1** provides a section view of the equipment for carrying out the direct thermal decomposition of hydrocarbons into solid carbon and hydrogen.
 - **Figure 2** corresponds to the equipment as shown in Figure 1, wherein the carbon solid particles generated during the process are also shown.
 - 30 • **Figure 3** provides a top view of the equipment as shown in Figures 1 and 2.

A list of the reference numbers used in the figures is given hereinbelow:

1. Hydrocarbon gas inlet
2. Gas distributor
- 35 3. Gas injection orifices distributed at the bottom of the liquid metal reactor

4. Thermal heaters
5. Liquid metal media
6. Hydrocarbon gas/hydrogen gas phase after injection
7. Pre-heating conduct
- 5 8. Carbon accumulation layer
9. Porous rigid section
10. Recipient suitable for collecting carbon particles
11. Carbon extraction outlet
12. Means for moving the porous rigid section (preferably a shaft)
- 10 13. Reactor pool
14. Energy input (14) for the thermal heaters (4)
15. Carbon barrier
16. Gas outlet collector
17. Gas mixture (H₂ + hydrocarbons) outlet
- 15 18. Thermal insulation means
19. Carbon particles.

Detailed description of the invention and disclosure of a preferred embodiment

20 Figures 1 and 2 show a particular embodiment of the device designed to carry out the process.

In the context of this document, a liquid metal reactor can be interpreted as a reactor wherein a gas-liquid chemical reaction takes place. Although in the figures it has a rectangular shape, other shapes are also possible. In addition, the cross section of the reactor can be varied in order to achieve a given nominal hydrogen flow rate production, as the hydrogen flow rate production will directly depend on the hydrocarbon injection rate at the bottom (kg HC/m²) and the conversion rate (depending on the operation temperature, generally around 0.8).

This process is particularly suitable for treating a C1-C5 hydrocarbon gas. In a preferred embodiment of the process, the hydrocarbon gas will consist of
 30 natural gas alone. In another embodiment, the hydrocarbon gas will be a mixture preferably comprising a hydrocarbon gas and nitrogen or any other inert gas suitable for keeping stable the gas hold-up close to its nominal conditions. The relation inert gas/hydrocarbon in the gas mixture will preferably be, in volume, 0/100 in nominal conditions, 50/50 during the operation of the reactor at 50% of its full capacity, and
 35 100/0 at warm stand-by conditions (at any temperature between 500 and 1100 °C) with

no H₂/C production. In this way, a stable operation will be achieved, working at a controlled flow rate.

The hydrocarbon gas stream will be fed to the equipment at a pressure and mass flow determined by the intended hydrogen and carbon production rate. In particular, the hydrocarbon gas stream will enter the equipment through at least one hydrocarbon gas inlet (1) and will be conducted through a pre-heating conduct (7) located surrounding the external perimeter of the liquid metal reactor, inside thermal insulation means (18). Said thermal insulation means (18) will be preferably made up of a material suitable for complying with a reasonable temperature (preferably equal to or below 70°C) at the outer surface in contact with the atmosphere surrounding the liquid media reactor, i.e., at a temperature required to comply with the safety regulation conditions in the site of the reactor.

Preferably, the hydrocarbon gas will be pre-heated until reaching a temperature between 500 and 700°C and more preferably between 650 and 700°C. Next, the pre-heated hydrocarbon gas stream enters the liquid metal reactor at the bottom part thereof. In particular, it is injected from a gas distributor (2) into the reactor pool (13) that contains a liquid metal media (5) through a porous section or a set of gas injection orifices (3) distributed along the bottom of the liquid metal reactor.

In a preferred embodiment of the invention, the reactor pool (13) will be built with a material compatible with the liquid metal in the presence of hydrogen and at temperatures generally equal to or below 1200°C. Preferably, this material can be quartz, since it has almost null corrosion rates in contact with the liquid metal used in the process, even at high temperatures. Other materials such as SiC, Al₂O₃, molybdenum, surface-coated steels or graphite can also be used.

In addition, the liquid metal media (5) can comprise, preferably, molten tin. However, other metal materials such as lead, a eutectic alloy (45/55) of lead and bismuth or a carbonate molten salt could also be used, such as NaCO₃.

Preferably, the liquid metal media (5) contained in the reactor pool (13) should exceed a level of 0.75 m to achieve a reasonable residence time of the hydrocarbon inside the reactor. The height of reactor pool (13) should be designed accounting for the choice of the liquid metal media (5) level, its hold-up due to the gas injection in nominal conditions, as well as the carbon accumulation layer (8), the porous rigid section (9) and the carbon barrier (15) plus a reasonable safety margin between 5 and 15% in height.

The liquid metal media (5) contained in the reactor pool (13) is heated until a

given operating temperature, preferably from 900 to 1200°C by at least one thermal heater (4) located inside the reactor pool (13). Preferably, the number of thermal heaters (4) inside the reactor pool (13) will vary from 1 (corresponding to approximately 1 kW) to at least 20 (corresponding to approximately 1 MW) and they will be physically
5 separated from the reactor pool (13) by a few centimeters gap (preferably between 0.5 and 5 cm), permitting the evacuation of flue gases. Such distribution of thermal heaters (4) is designed in number and position to obtain a homogeneous temperature in the liquid metal media (5).

The thermal heaters (4) may comprise gas burners of a fuel that may consist of a
10 mixture of natural gas and hydrogen at any range (including the possibility of being only natural gas or only hydrogen). In other embodiments, the thermal heaters (4) may comprise at least one carbon electrode heater. The required energy input (14) for the thermal heaters (4), in the form of fuel or electricity, will be provided at the bottom of
15 said thermal heaters (4), by a convenient perforation in the thermal insulation means (18) of the liquid metal reactor. Preferably, the thermal heater (4) will be controlled to provide both the energy required to compensate the thermal losses of the equipment to the ambient and the input required for the endothermic decomposition reaction.

The hydrocarbon gas injected into the liquid metal media (5) moves upwards by buoyancy forming bubbles (6) or another similar two-phase flow. At the same time, the
20 hydrocarbon gas is decomposed into hydrogen and solid carbon. The conversion to hydrogen will depend on the temperature of liquid metal media (5) and the residence time of the gas inside the liquid metal reactor. Such residence time, for example, depends on the vertical height of the liquid media reactor, as well as on the characteristics of the liquid metal media (5). A higher height implies a higher residence
25 time and a higher conversion. For example, at around 1200°C and 1 m height, the conversion rate will be of the order of 75%.

As a result of the decomposition reaction, the carbon produced will be accumulated at the top of the liquid metal media (5), forming a carbon accumulation
30 layer (8) on its free surface, which will grow due to the accumulation of carbon particles (19) produced during the continuous operation of the liquid metal reactor. Above the free surface of the liquid metal media (5), a porous rigid section (9) is located. After a certain operation time, this porous rigid section (9) is filled with carbon particles (19), once the carbon layer (8) has reached a determined thickness. The porosity of this porous rigid section (9) may vary from 0.2 to 0.8 (measured by standard methods, such
35 as differential volume estimation). Preferably, this porosity value will be determined as

a compromise between the expected carbon production rate and the elapsed time between carbon removal cycles. The height of the porous rigid section (9) will depend on the carbon production capacity of the system, generally ranging from 1 to 50 centimeters, approximately. Preferably, the porous rigid section (9) will be made from a ceramic, a metallic material, quartz or any other material compatible with a hydrogen rich atmosphere at the temperatures equal to or below 1200°C.

The carbon particles (19) will then be conducted from the porous rigid section (9) to at least one recipient suitable for collecting them. Preferably, the equipment will comprise at least two recipients or tanks (10) located at the top of the liquid metal reactor, one opposite the other, spreading outwards from the reactor. These recipients (10) will have enough size to allow collecting all the carbon particles (19) coming from the porous rigid section (9). Preferably, the carbon particles (19) will be driven by a mechanic shaft (12), which will alternatively displace the porous rigid section (9) from one recipient (10) to the other, as shown in Figures 2 and 3. The carbon particles (19) constituting the porous rigid section (9) will then fall (generally by gravity) into the recipients (10), helped if needed by the vibration of the mechanic shaft (12) or any other dynamic means such as the circulation of an inert gas. The carbon particles (19) collected at the recipients (10) will then be removed from the liquid metal reactor, for example, by means of at least one carbon extraction outlet (11) located in each of the recipients (10).

Preferably, the porous rigid section (9) will have at least double the size of the reactor cross section in order to allow collecting the carbon particles (19) at the rigid porous section (9), at the same time that the carbon particles (19) are removed by gravity, enhanced with mechanical vibrations. This is shown in figures 2 and 3.

The gas phase resulting from the reaction crosses the porous rigid section (9) and leaves the reactor at the top, through a gas outlet collector (16). This gas outlet collector (16) concentrates the gas comprising hydrogen and other hydrocarbons before leaving the equipment through at least one gas mixture outlet (17).

Preferably, between the porous rigid section (9) and the gas outlet collector (16) a gas departiculation section comprising a carbon barrier (15) is also located. Said carbon barrier (15) may comprise cross laminates, which will be preferably made of a ceramic or a metallic material compatible with a hydrogen-rich atmosphere and the structural material of the reactor pool (13). This gas departiculation section will avoid the flow of carbon particles (19) in the gas outlet (17) of the equipment. In this way, the gas stream leaving the reactor will be a hydrogen-rich gas mixture that will be able to

be conducted to its direct application or to a conditioning process to purify the hydrogen stream and/or adapt its temperature and pressure.

The equipment may be designed as to obtain hydrogen flow rates (in terms of energy) from 100 W to 250 MW, approximately. Also, it will be possible to operate one
5 single reactor or multiple reactors, depending on the results to be achieved.

In addition, conversion rates from the hydrocarbon gas (preferably methane) to hydrogen in the equipment will depend on the temperature and height of the liquid metal media (5), being able to achieve transformation rates from 20 to 80%.

10 Example of one particular embodiment of the invention

In the following table, a preferred configuration of the reactor object of the present invention is described for an industrial scale application producing 6 tons per hour of hydrogen, what corresponds to approximately 73000 m³N/h of hydrogen and 23.6 t/g of carbon, with tin as liquid metal.

		Unit
Tin filling height	1	m
Tin volume	213.2	m ³
Gas pressure at inlet	15	bar
Gas hold-up	0.153	m
Porous section thickness	0.07	m
Porous section position from methane injection	1.16	m
Hydrogen production	2.15	kg/s
Carbon production	6.46	kg/s
Inlet methane flow rate	14.7	kg/s
Heating power of thermal heaters	58	MW
Reactor temperature	1100	°C
Cross section reactor	213.2	m ²
Conversion gas-H ₂	58.6	%
Carbon extraction cycling	500	S

15

In this example, a nominal methane flow rate of 14.7 kg/s was fed into the liquid metal reactor at a pressure of 15 bar. Preferably, the hydrocarbon gas is pre-heated until reaching a temperature between 500 and 700°C. Next, the pre-heated hydrocarbon gas stream enters the liquid metal reactor at the bottom part thereof, said

reactor having a cross section of 213.2 m². In particular, it is injected into a reactor pool that contains a liquid metal media of 1 m height. In this particular embodiment, the liquid media consists of molten tin and it is at a temperature of 1100°C.

The hydrocarbon gas injected into the liquid metal media moves upwards by
5 buoyancy forming bubbles. At the same time, the hydrocarbon gas is decomposed into hydrogen (at a rate of 2.15 kg/s) and solid carbon (at a rate of 6.46 kg/s). The conversion to hydrogen in this case is of 58.6%, as it is operating at 1100 °C.

As a result of the decomposition reaction, the carbon produced is accumulated at the top of the liquid metal media forming a carbon layer on its free surface, which will
10 grow due to the accumulation of carbon particles produced during the continuous operation of the liquid metal reactor. Above the free surface of the liquid metal media a porous rigid section is located, in particular, at a height of 1.16 m from the methane injection. This porous rigid section is filled with carbon particles, once the carbon layer has reached a thickness of 0.07 m. The carbon particles are then driven by a mechanic
15 shaft from the porous rigid section to two recipients suitable for collecting them, one opposite the other. The carbon particles collected at the recipients are then removed from the liquid metal reactor, for example, by means of at least one carbon extraction outlet located in each of the recipients.

The gas phase resulting from the reaction crosses the porous rigid section and
20 leaves the reactor at the top, through a gas outlet collector. This gas outlet collector concentrates the gas comprising hydrogen and other hydrocarbons before leaving the device through at least one gas mixture outlet. In this particular embodiment, the height of the gas hold-up is of 0.153 m. The gas stream leaving the reactor is a hydrogen-rich gas mixture containing 6.08 kg/s of methane and 2.15 kg/s of hydrogen (73.8/26.2%
25 weight; 26.1/73.9% mol).

CLAIMS

1. A process for the direct thermal decomposition of hydrocarbons into solid carbon and hydrogen gas comprising:
 - 5 a. preheating a hydrocarbon gas stream by conducting the hydrocarbon gas stream from at least one hydrocarbon gas stream inlet, located at a top part of a liquid metal reactor, to a bottom part of the liquid metal reactor, through a pre-heating conduct located surrounding an external perimeter of the liquid metal reactor, said pre-heating conduct being located inside a thermal insulation means, to obtain a pre-heated hydrocarbon gas stream at a temperature between 500 and 700°C;
 - 10 b. injecting the pre-heated hydrocarbon gas stream obtained in step (a) into a reactor pool of the liquid metal reactor containing a liquid metal media, wherein said injection takes place at the bottom part of the liquid metal reactor through a porous section or a set of gas injection orifices;
 - 15 c. the hydrocarbon gas injected into the liquid metal reactor in step (b) moves upwards by buoyancy forming a multi-phase flow, the hydrocarbon gas decomposing into hydrogen gas and solid carbon while the liquid metal media inside the reactor pool is maintained at a temperature comprised between 900 and 1200°C;
 - 20 d. the solid carbon obtained in step (c) is accumulated at the top of the reactor pool, on a free surface of the liquid metal media located inside the liquid metal reactor, forming a carbon layer made up of solid carbon particles;
 - 25 e. once the carbon layer reaches a determined thickness, the carbon particles constituting the carbon layer are displaced into at least one carbon extraction system consisting of a porous rigid section located at the top of the liquid metal reactor, above the free surface of the liquid metal media, from which the carbon particles are conducted into at least one recipient for collecting the carbon particles; and,
 - f. while the solid carbon accumulates at the top of the reactor pool, the gas comprising hydrogen obtained in step (c) leaves the reactor pool through the porous rigid section, being collected at a gas outlet collector from where the hydrogen gas finally leaves the liquid metal reactor.
- 30 2. The process according to claim 1, wherein the temperature inside the reactor pool is reached by means of at least one thermal heater located inside the reactor pool.

3. The process according to claim 1 or 2, wherein the thickness of the carbon layer reached in step (c) is between 1 and 15 cm.
4. The process according to any one of claims 1 to 3, wherein the conduction of the carbon particles towards the at least one recipient for collecting said carbon particles is
5 facilitated by a vibrational movement generated by a mechanical shaft.
5. A device for carrying out the process as claimed in any one of claims 1 to 3, comprising:
 - a. the pre-heating conduct comprising at least one hydrocarbon gas stream inlet located at the top of the liquid metal reactor and at least one hydrocarbon gas outlet
10 located at the bottom part of the liquid metal reactor corresponding to the hydrocarbon gas inlet into the reactor pool designed for containing the liquid metal media, wherein said pre-heating conduct is located inside the thermal insulation means;
 - b. the liquid metal reactor further comprising at least one thermal heater located inside
15 the reactor pool for inducing a homogeneous temperature inside the liquid metal reactor;
 - c. in addition, at least one carbon extraction system consisting of the porous rigid section is located at the top of the liquid metal reactor, said porous rigid section being connected to the at least one recipient for collecting the carbon particles;
 - 20 d. the porous rigid section also incorporating, at the top of it, a carbon barrier designed for carbon particle retention, wherein said carbon barrier separates the porous rigid section from the gas outlet collector.
6. The device according to claim 5, wherein the connection between the porous rigid section and the at least one recipient for collecting the carbon particles further
25 incorporates mechanical means for facilitating movement of the solid carbon particles.
7. The device according to claim 6, wherein the mechanical means comprises a mechanical shaft that generates vibrational movement to facilitate the movement of the carbon particles towards the at least one recipient for collecting said carbon particles.

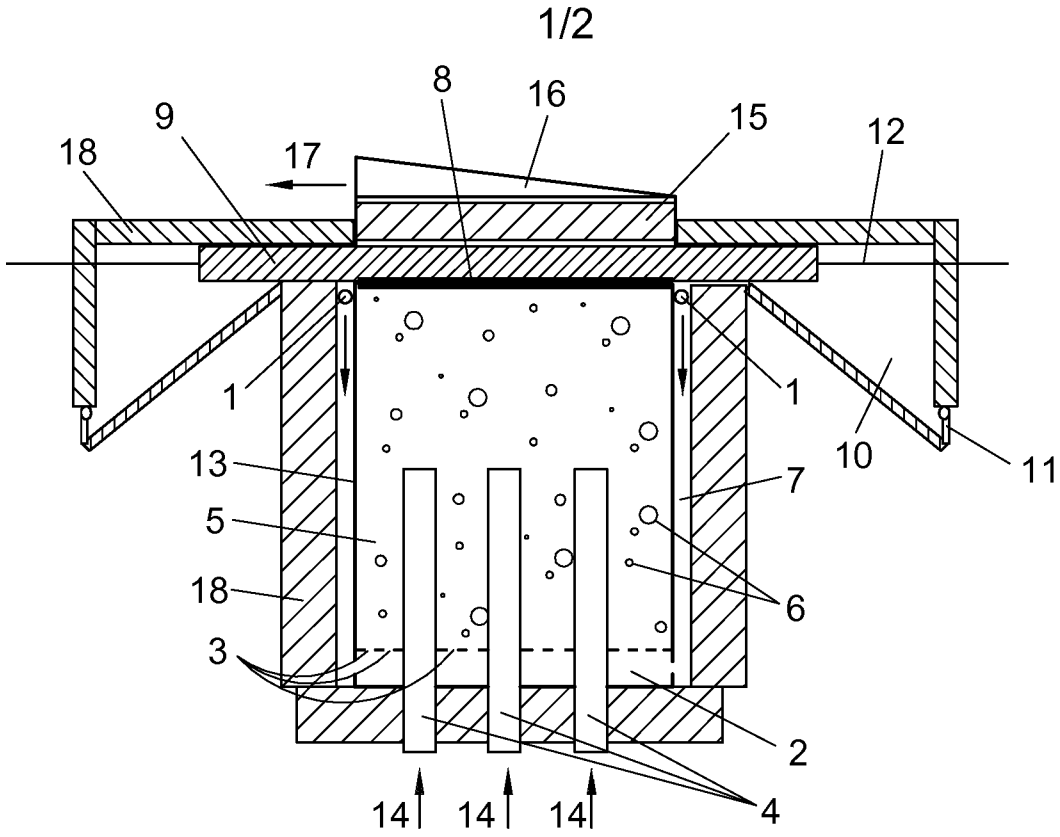

FIG. 1

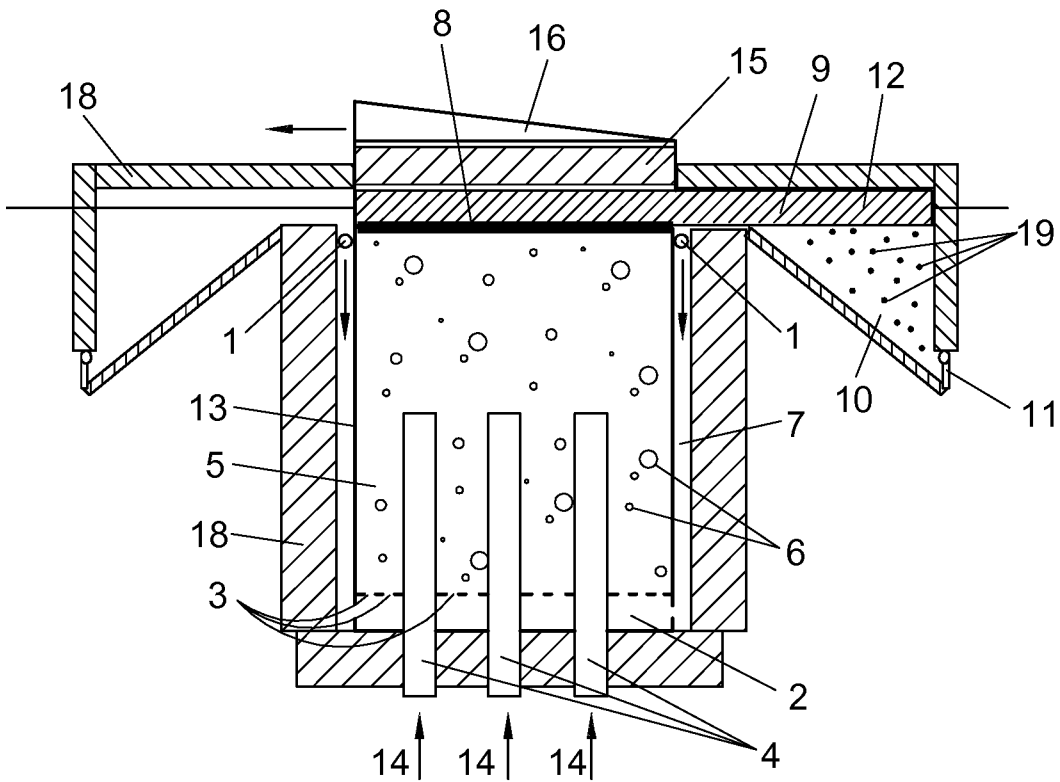

FIG. 2

2/2

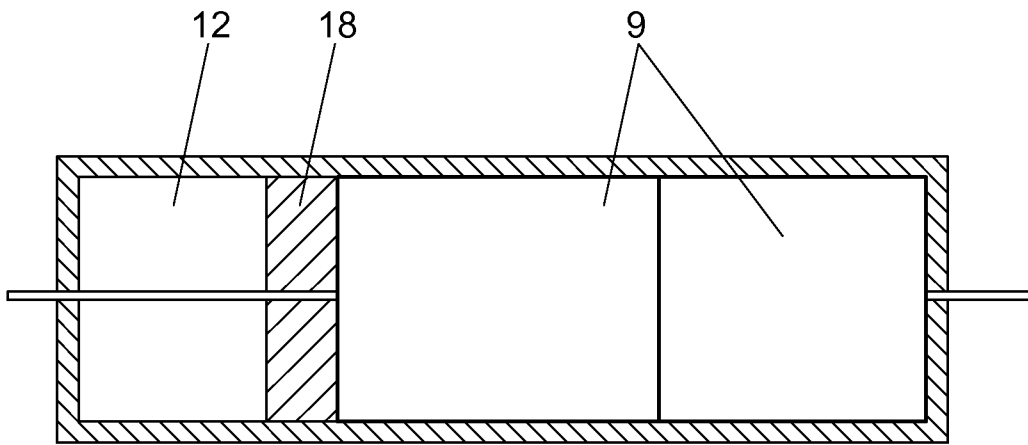

FIG. 3

