



US006056511A

**United States Patent** [19]  
**Kennedy et al.**

[11] **Patent Number:** **6,056,511**  
[45] **Date of Patent:** **May 2, 2000**

- [54] **CONNECTION MODULE FOR A SUBMERGIBLE PUMPING SYSTEM AND METHOD FOR PUMPING FLUIDS USING SUCH A MODULE**
- [75] Inventors: **Steven C. Kennedy; Lawrence Lee**, both of Bartlesville, Okla.; **Jay S. Mann**, Sherwood Park, Canada
- [73] Assignee: **Camco International, Inc.**, Houston, Tex.
- [21] Appl. No.: **09/006,552**
- [22] Filed: **Jan. 13, 1998**
- [51] **Int. Cl.<sup>7</sup>** ..... **F04B 19/00**
- [52] **U.S. Cl.** ..... **417/53; 417/423.3; 417/424.1**
- [58] **Field of Search** ..... **417/423.3, 424.1, 417/424.2, 422, 53**

[56] **References Cited**

**U.S. PATENT DOCUMENTS**

3,853,430	12/1974	O'Rourke	417/360
4,296,810	10/1981	Price	166/265
5,207,562	5/1993	Neibrook et al.	417/234
5,297,943	3/1994	Martin	317/422
5,620,048	4/1997	Beauquin	166/62
5,842,520	12/1998	Bolin	166/369

**FOREIGN PATENT DOCUMENTS**

466187 1/1992 European Pat. Off. .

*Primary Examiner*—Charles G. Freay  
*Assistant Examiner*—David J. Torrente  
*Attorney, Agent, or Firm*—Fletcher, Yoder & Van Someren

[57] **ABSTRACT**

A connection module is disclosed for a submergible pumping system of the type including a submergible electric motor and a pump drivingly coupled to the motor. The system may also include additional components such as a fluid separator, an injection pump, and so forth. The connection module includes a body through which a fluid passage is formed. A recess is formed in the body for receiving a cable for transmitting power to the submergible electric motor. The fluid passage transfers fluid within the pumping system, such as by means of shrouds disposed around the system components. The connection module also includes an electrical connector for completing current carrying paths between a supply cable and the motor. The connection module may thus serve as the motor head in which the electrical connections are made, but through which fluid is channeled to system components. The module is particularly useful for connecting a shroud around the motor, while accommodating the power cable entry at an end of the motor.

**26 Claims, 10 Drawing Sheets**

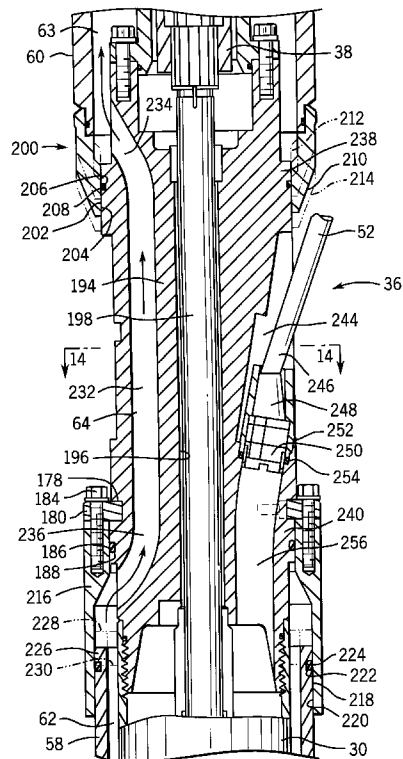
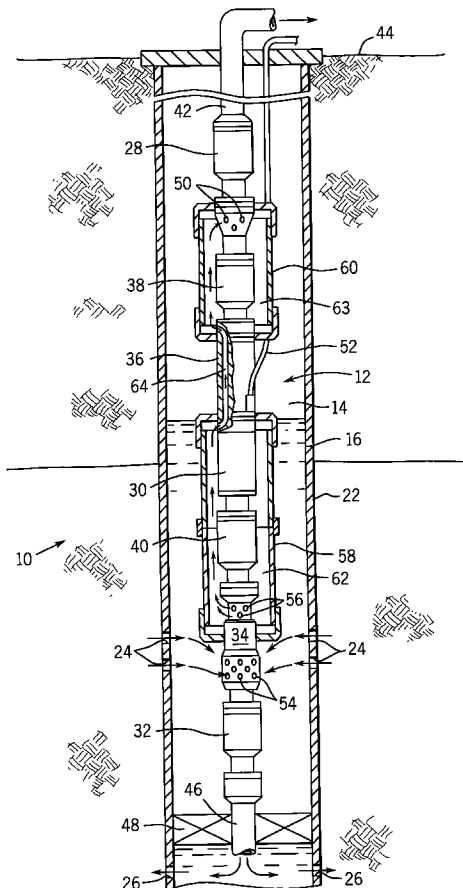

FIG. 1  
PRIOR ART

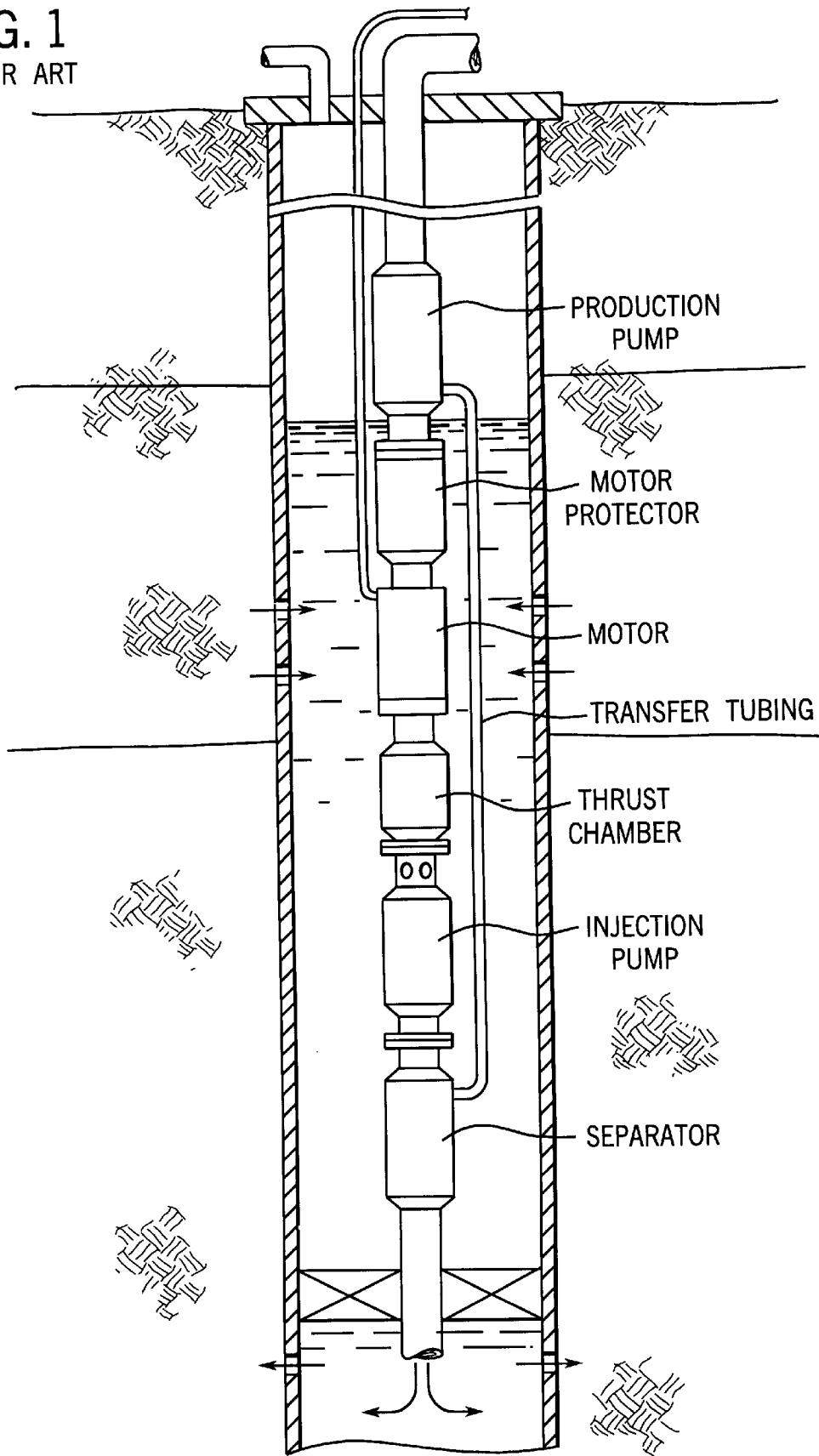



FIG. 3

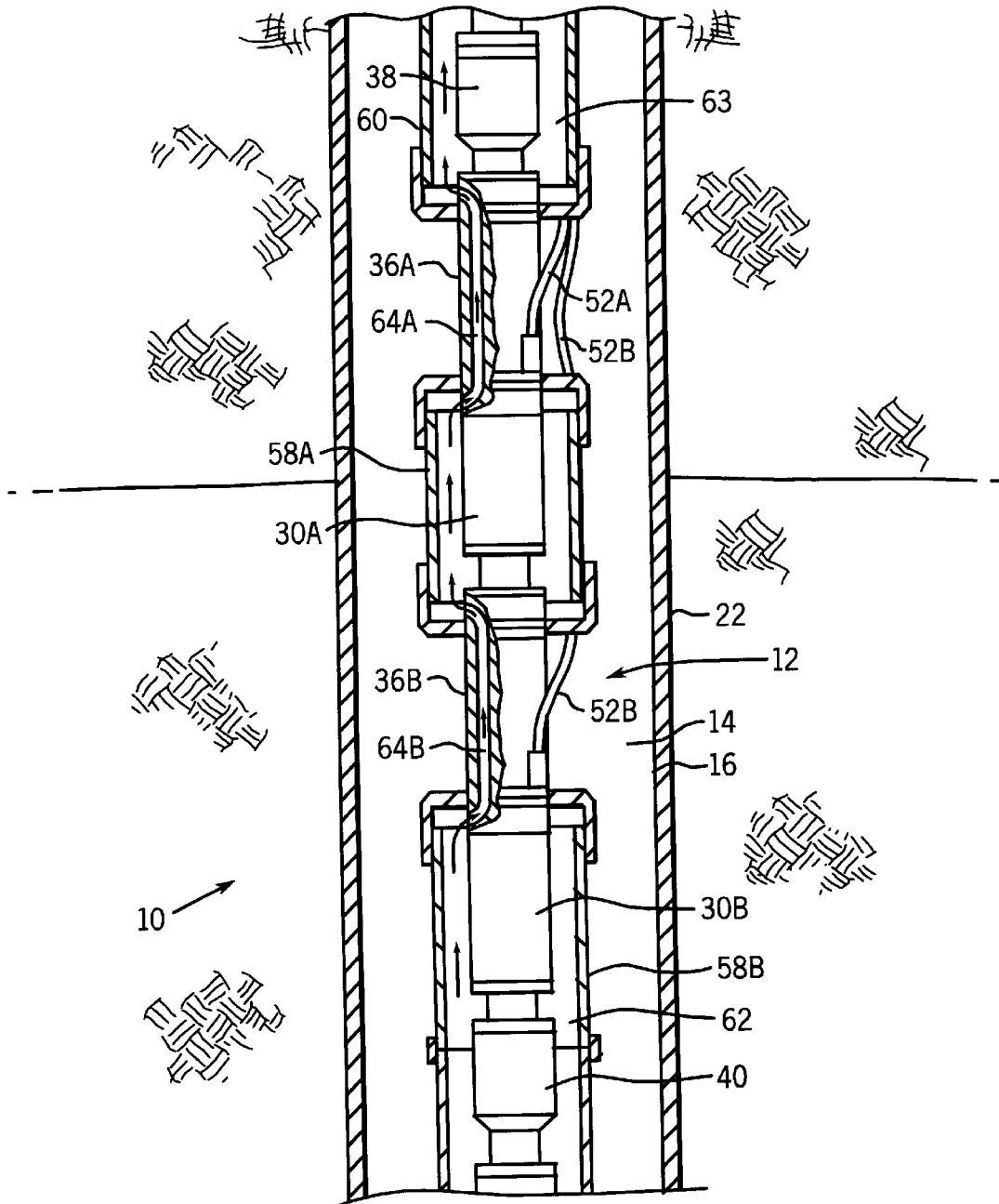

FIG. 4

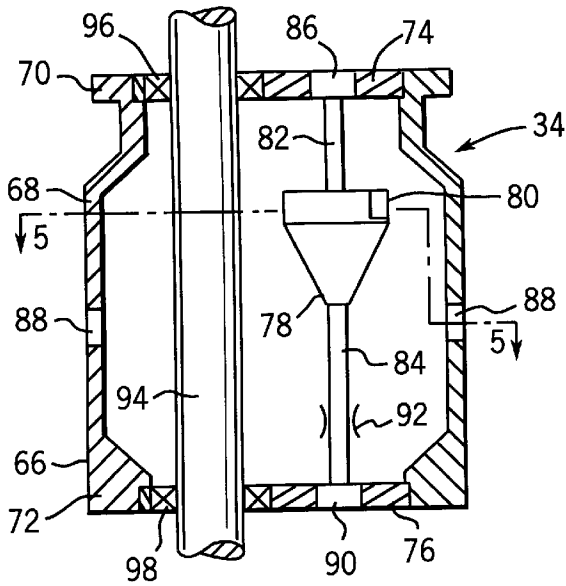

FIG. 5

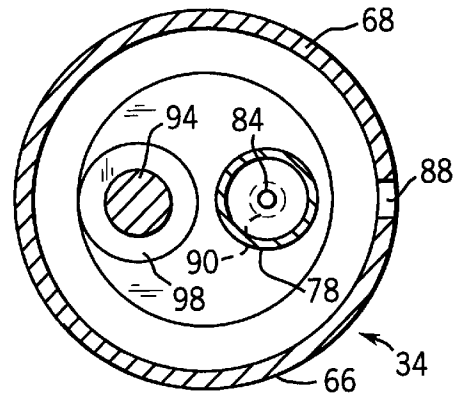
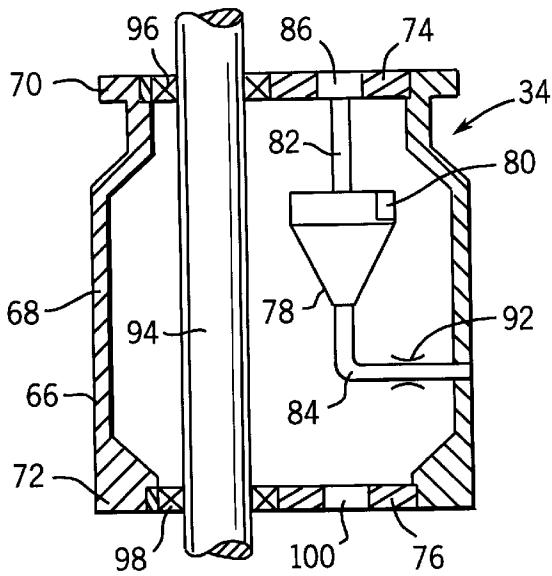

FIG. 6



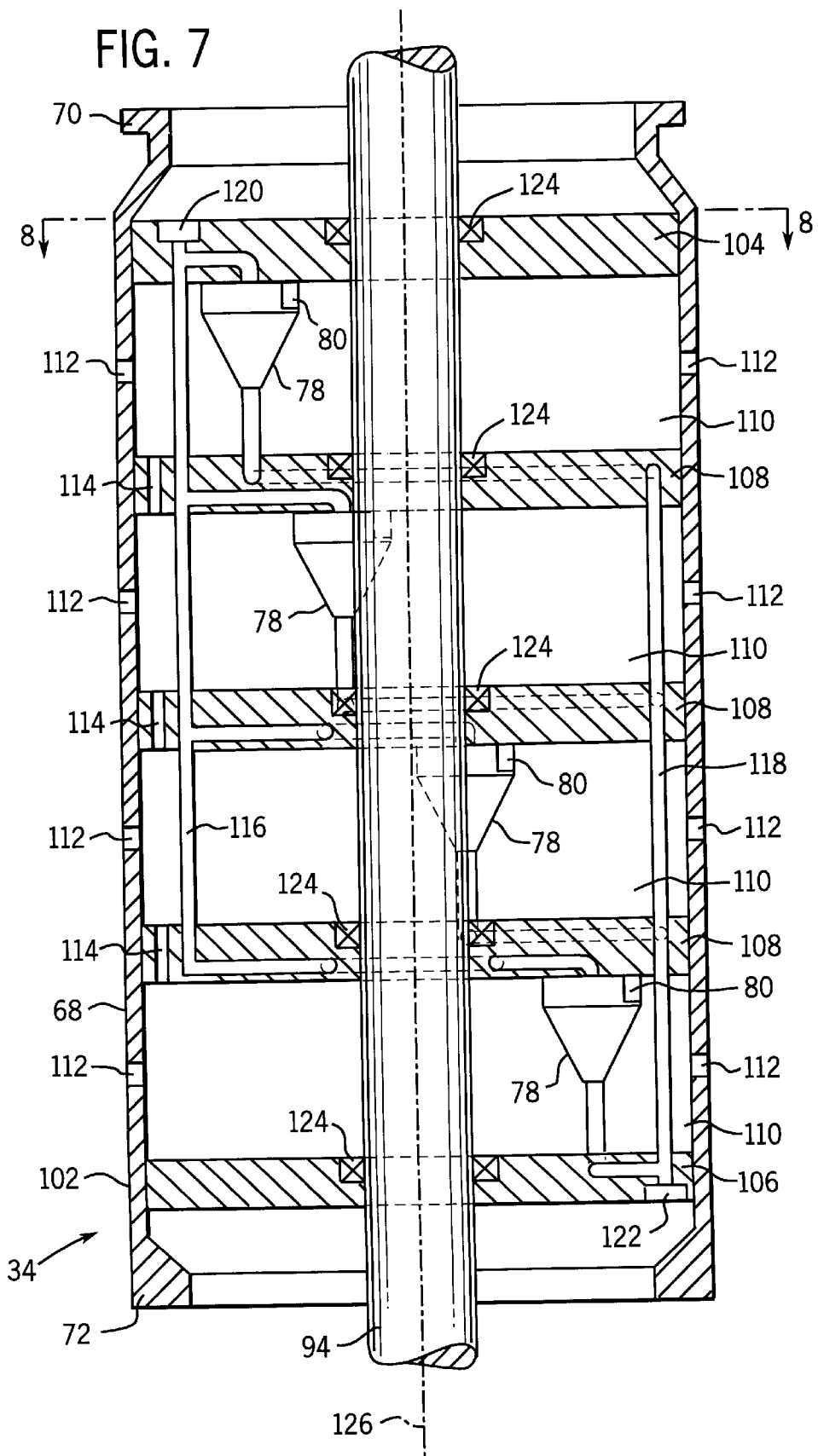

FIG. 8

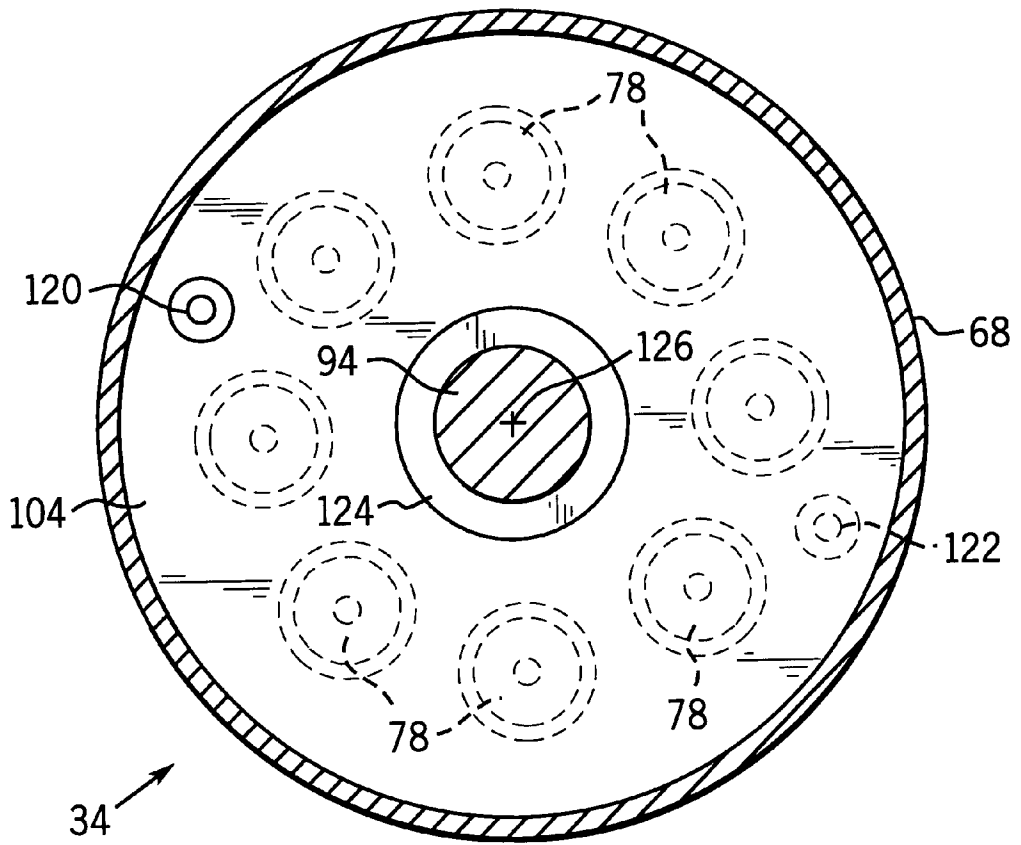

FIG. 9

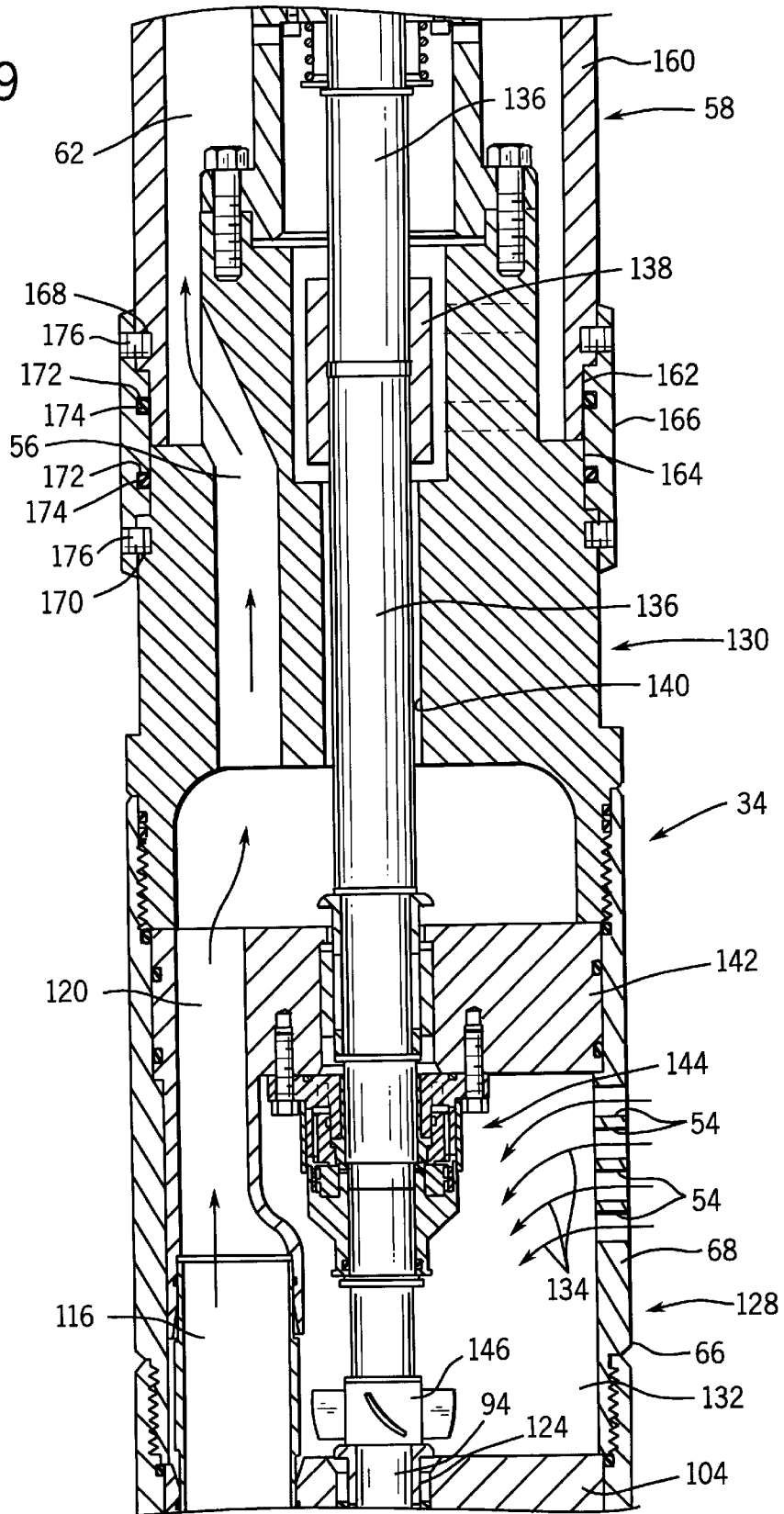



FIG. 10

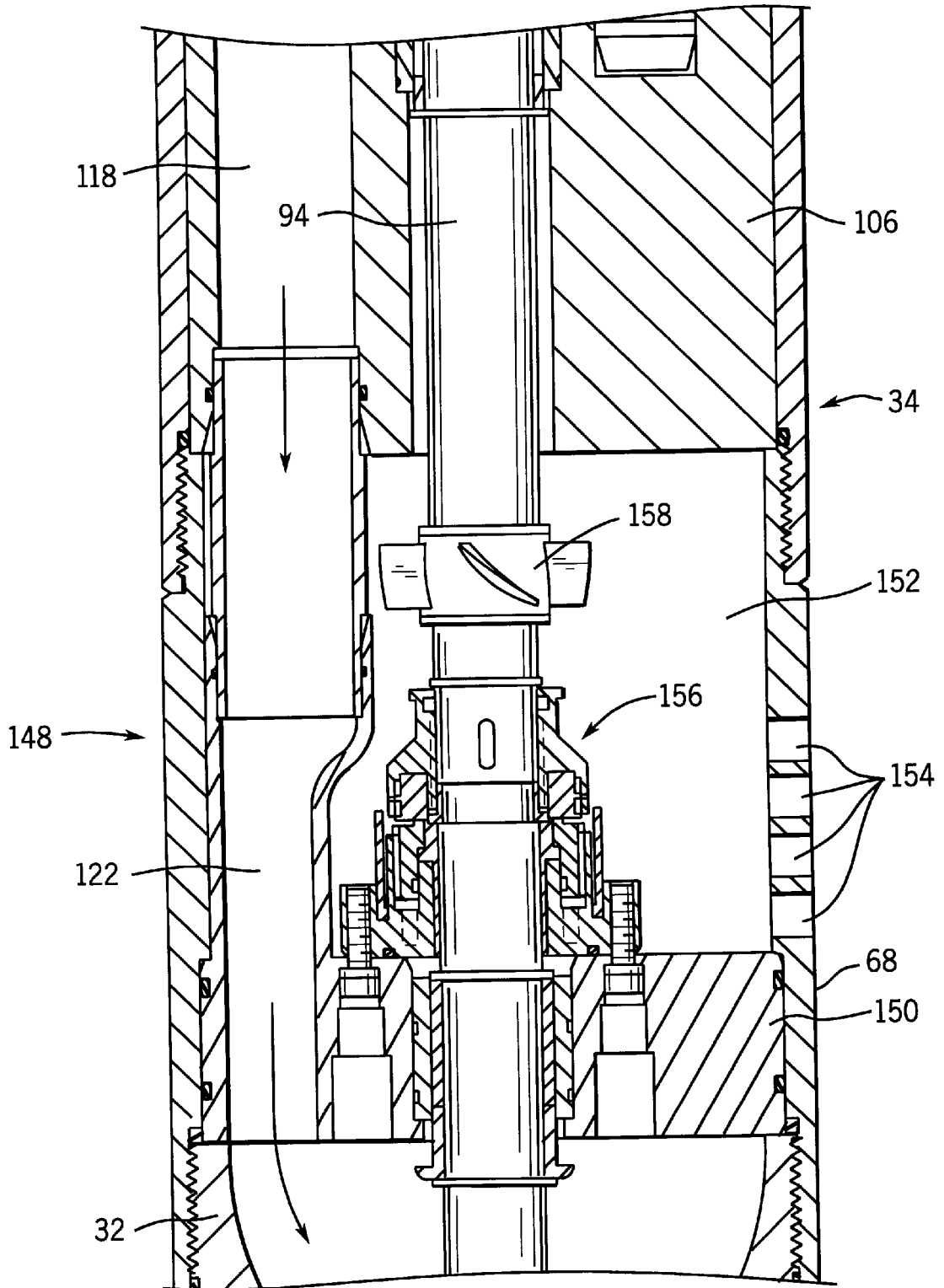

FIG. 11

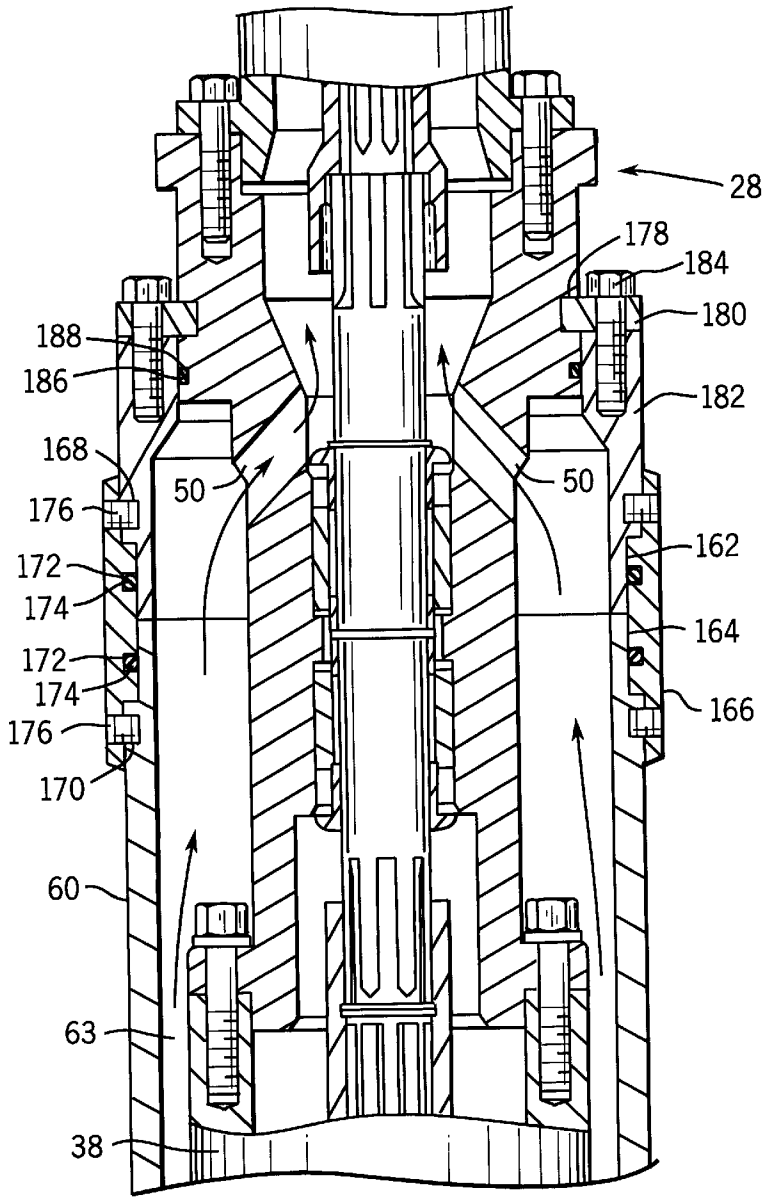

FIG. 12

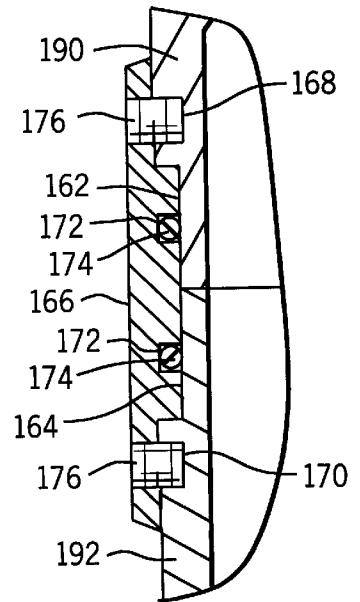

FIG. 13

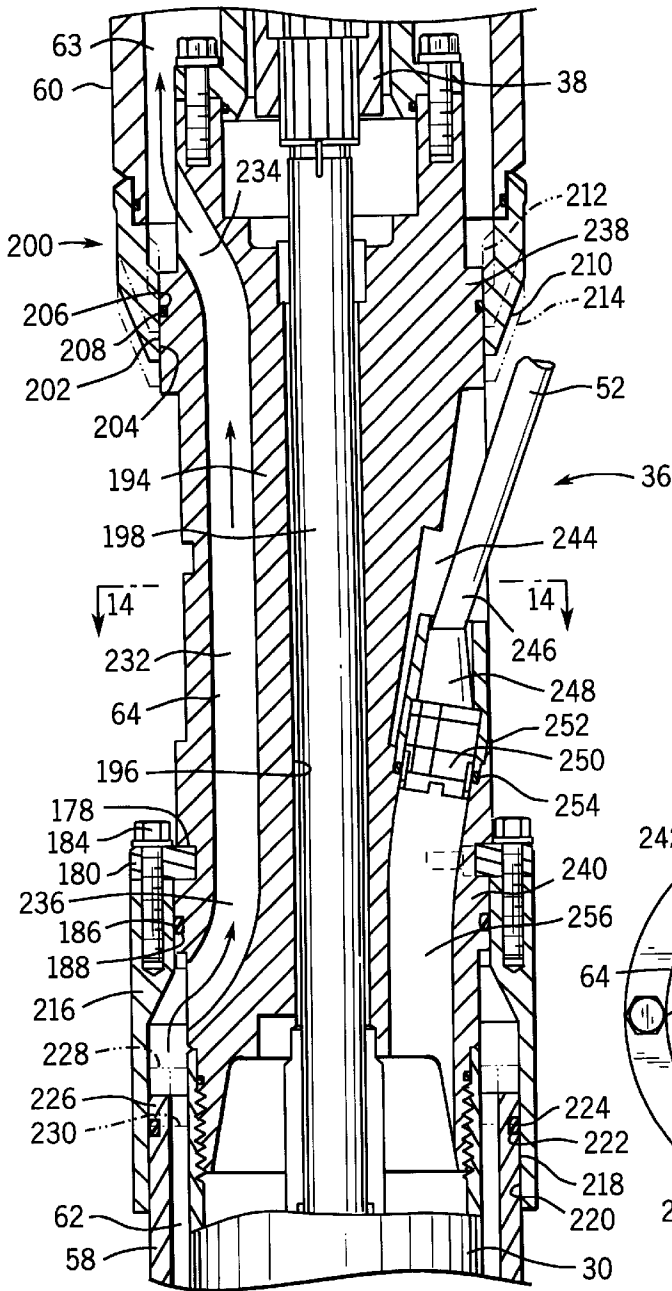
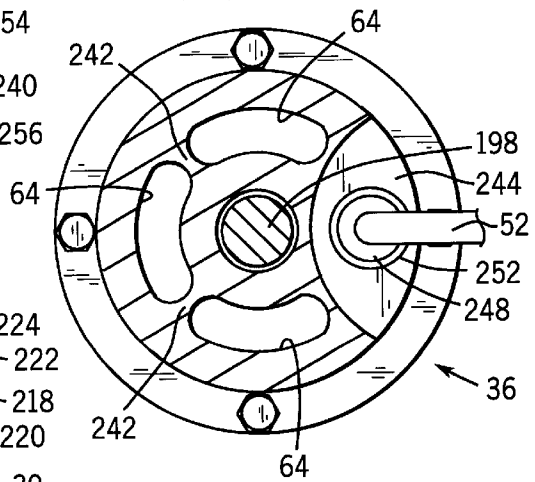

FIG. 14



**CONNECTION MODULE FOR A  
SUBMERGIBLE PUMPING SYSTEM AND  
METHOD FOR PUMPING FLUIDS USING  
SUCH A MODULE**

BACKGROUND OF THE INVENTION

1. Field of the Invention

This invention relates generally to the field of pumping systems for raising fluids from wells. More particularly, the invention relates to a novel technique for directing fluid from one element of a submergible pumping system, such as a fluid separator, to another element of the pumping system, such as a production pump. The technique facilitates channeling of the fluid displaced by the pumping system.

2. Description of the Related Art

In producing petroleum and other useful fluids from production wells, it is generally known to provide a submergible pumping system for raising the fluids collected in a well. In general, production fluids will enter a well via perforations formed in the well casing adjacent to a production formation. The fluids contained the formation will then collect in the wellbore and may be raised by the pumping system to a collection point above the earth's surface. In many instances, non-production fluids may also accumulate in the wellbore. Such non-production fluids may include water, brine and other fluids of less commercial interest.

Known pumping systems for raising production fluids from wells typically include a submergible electric motor coupled to a production pump. The electric motor is supplied with electrical power via a cable extending to power supply and control circuitry above the earth's surface. The production pump draws in production fluids and forces the production fluids to the earth's surface via a conduit, such as a stand of coil tubing. Where wellbore fluids include a significant quantity of non-production fluids, the pumping system may include a separator for separating the production fluids from the non-production fluids. The non-production fluids may be reinjected into a subterranean discharge or disposal zone either directly from the separator or via a separate injection pump. The injection pump may also be driven by the same electric motor used to drive the production pump.

Depending upon the relative positions of the production and discharge zones in the well, various configurations of the components described above may be employed. For example, a separator may be positioned below the electric motor used to drive the production pump. Production fluid output from the separator must then be channeled upwardly in the pumping system from the separator production outlet to the intake of the production pump. In general, it is preferable to channel at least a portion of the fluids displaced by the pumping system adjacent to the electric motor so as to convectively cool the electric motor by the fluid flow. Shrouds may be employed in such situations to channel fluids in annular regions between the shrouds and the outer periphery of the pumping system. The use of such shrouds also facilitates the piping of the pumping system by reducing the need to provide separate fluid conduits between the system components.

In submergible pumping systems employing shrouds for directing fluids between system components, a difficulty arises in making necessary electrical connections with the submergible electric motor. In particular, a shroud is most effective in aiding to cool the electric motor when it is installed to extend at least partially along the outer surface of the motor. However, an electrical connection must be

made between the power supply and control cable and the electric motor to power the motor during operation of the system. The cable may be brought through a continuous shroud and sealed at a point of entry through the shroud wall.

5 However, the resulting structure is relatively difficult to assemble and may result in leakage into or out of the shroud during use. Alternatively, packers may be employed between the pumping system and the well casing to eliminate the need for a shroud. However, this arrangement generally requires that the electrical cable be passed through at least one packer to the electric motor. In another solution, a lower shroud portion may be provided around the electric motor, and an upper shroud portion provided to the production pump inlet, with a separate external conduit coupled to both shroud portions. However, this structure also may be prone to leakage and somewhat defeats the purpose of reducing space requirements by virtue of the shroud.

10 There is a need, therefore, for an improved technique for directing fluids in a submergible pumping system which addresses and at least partially overcomes the drawbacks and disadvantages of existing systems. In particular, there is a need for an improved arrangement for directing fluids around a submergible electric motor and to the inlet of a submergible pump, while permitting electrical connection to be completed between surface equipment and the electric motor via a cable.

SUMMARY OF THE INVENTION

The present invention provides a novel technique for channeling fluids in a submergible pumping system designed to respond to these needs. The technique may be employed in pumping systems having a variety of configurations, including a single or multiple electric motors, a single production pump, or production and injection pumps, and with or without a fluid separator. The technique employs a connection module for a submergible electric motor in which the necessary electrical connections can be made with a power supply cable. The connection module interfaces with a lower shroud portion and an upper shroud portion, directing fluid through channels formed in the connection module. Fluid may thus be channeled over the electric motor, through the connection module and to the pump. One or more such connection modules may be employed in a pumping system, depending upon the number of electric motors included in the system and the piping requirements of the system components.

Thus, in accordance with a first aspect of the invention, a connecting module is provided for a submergible pumping system. The pumping system is of the type comprising a plurality of components, including a submergible electric motor coupled to a pump. The pumping system is submergible within a well to pump fluids from the well. The connecting module includes a body configured to be coupled within the pumping system. A fluid passage is formed in the body for channeling a flow of fluid to the pump. A recess is formed in an outer periphery of the body for receiving at least one conductor for transmitting electrical power or data to the motor from a location outside the well. In a particularly preferred embodiment, the body includes first and second ends and a peripheral outer wall. The fluid passage extends through the outer wall adjacent to the first and second ends. In accordance with another particularly preferred embodiment, an electrical connector is provided in the module for completing electrical current carrying paths between the electric motor and power conductors extending from the earth's surface.

In accordance with another aspect of the invention, a motor head connecting module is provided for use in a

submergible pumping system. The pumping system is of the type comprising a plurality of interconnected components including a pump for raising wellbore fluids from a well to the earth's surface, and a submergible electric motor coupled to the pump for driving the pump. The pumping system also includes a conduit coupled to the pump for transferring fluids from the pump. A power cable is coupled to the motor for supplying electrical power to the motor. The connecting module comprises a body configured for attachment to the electric motor and to a second component of the pumping system. A fluid passage extends at least partially through the body for conveying fluid from a first location adjacent to the motor to a second location distal from the motor. An electrical connector is provided in the body for coupling the power cable to the electric motor and for transmitting electrical power therebetween.

In accordance with a further aspect of the invention, a submergible pumping system is provided for raising fluids from a well. The system comprises a submergible pump having an inlet and an outlet, and a submergible electric motor operatively coupled to the pump. A fluid conduit is provided for conveying fluid from the pump outlet to a location above the earth's surface. A power cable is coupled to the motor for supplying electric power to the motor. A connection module is disposed between the pump and the motor. The connection module includes a fluid passage for directing fluid from a first location adjacent to the motor to a second location distal from the motor. The connection module also includes a recess for receiving the power cable. Means are provided for directing fluid from the second location to the pump inlet. A shroud is provided for directing flow of fluid around at least a portion of the motor and into the fluid passage at the first location.

In accordance with yet another aspect of the invention, a method is provided for directing flow in a submergible pumping system of the type including a submergible pump and a submergible electric motor for driving the pump. In accordance with the method, a connection module is coupled between the motor and the pump, the connection module including a fluid passage and an electrical connector coupled to a power supply cable. A shroud is then coupled around at least a portion of the motor to direct fluid to the fluid passage. Fluid conducting means are coupled between the fluid passage and the pump inlet. The pumping system is then positioned at least partially in fluids within a well, and the motor is energized via the power cable to circulate fluid from the well through a fluid flow path. The fluid flow path is defined by the shroud, the fluid passage, the fluid conducting means, the pump and the fluid conduit. The system may include a fluid separator for separating production fluids from non-production fluids. In such systems, the fluid circulated through the fluid flow path is preferably the production fluid.

### BRIEF DESCRIPTION OF THE DRAWINGS

The foregoing and other advantages and features of the invention will become apparent upon reading the following detailed description and upon reference to the drawings in which:

FIG. 1 is a vertical elevational view of a pumping system positioned in a wellbore in accordance with a prior art technique for separating wellbore fluids, pumping production fluids to a location above the earth's surface, and disposing of non-production fluids;

FIG. 2 is a vertical elevational view of a pumping system in accordance with certain aspects of the present invention

configured for separating wellbore fluids into production and non-production fluids, and for transmitting production fluids through components of the pumping system, while transferring non-production fluids to a subterranean injection zone;

FIG. 3 is a vertical elevational view of a portion of a pumping system of the type illustrated in FIG. 2, showing a preferred manner for coupling two separate drive motors in the pumping system in lieu of a single drive motor;

FIG. 4 is a diagrammatical vertical sectional view of a drive-through separator for use in a pumping system of the type illustrated in FIG. 2, including a through shaft and a hydrocyclone separator venting through an end plate of the separator unit;

FIG. 5 is a sectional view of the separator illustrated in FIG. 4 along line 5—5, illustrating the position of the internal elements of the separator unit;

FIG. 6 is a diagrammatical vertical sectional view of an alternative configuration of the drive-through separator of FIG. 4, wherein the separator vents through a side wall of the unit;

FIG. 7 is a diagrammatical vertical sectional view of an alternative configuration of a drive-through separator including a series of hydrocyclone separators and a shaft disposed coaxially within the housing of the unit;

FIG. 8 is a sectional view through the separator illustrated in FIG. 7 along line 8—8, illustrating the positions of internal components of the separator with respect to one another;

FIG. 9 is a sectional view through an upper end of a separator of the type illustrated in the Figures above, showing a preferred manner for channeling fluids through the internal passageways in the end of the separator and into an extensible shroud for communicating production fluids to other components of the pumping system;

FIG. 10 is a sectional view through a lower end of a separator of the type illustrated in the preceding Figures;

FIG. 11 is a sectional view through a portion of the pumping system of FIG. 2, illustrating a preferred manner for securing an extensible shroud to a lower intake of a production pump;

FIG. 12 is a sectional detail view of a portion of an extensible shroud illustrating a preferred manner for joining tubular sections of the shroud;

FIG. 13 is a sectional view through a connection module of the type illustrated in FIGS. 2 and 3, showing the manner in which internal passageways and electrical cable connections are made within the connection module, as well as the manner in which extensible shroud sections are coupled to the pumping system in which the connection module is disposed; and

FIG. 14 is a sectional view through the connection module of FIG. 13 along line 14—14, illustrating a preferred arrangement of internal passageways within the connection module.

### DETAILED DESCRIPTION OF SPECIFIC EMBODIMENTS

Turning now to the drawings, and referring first to FIG. 1, a pumping system is illustrated for separating wellbore fluids in accordance with certain heretofore known techniques. Specifically, the pumping system includes a production pump, a motor, an injection pump and a fluid separator. A motor protector is positioned intermediate the production pump and the motor. The motor is configured for driving both the production pump and the injection pump via

internal power transmission shafts. The separator is positioned below the injection pump to receive flow from the injection pump. In operation, fluids enter the wellbore adjacent to the pumping system and are drawn into the injection pump. Fluids are then forced through the separator where production fluids are separated from non-production fluids, typically water. Production fluids are then transferred via transfer tubing to the production pump, while non-production fluids are injected into a discharge zone isolated by a set of packers. Production fluid from the production pump is forced to the earth's surface where it is collected and further processed.

FIG. 2 illustrates a pumping system in accordance with certain aspects of the present invention. The pumping system illustrated in FIG. 2 is designated generally by the reference numeral 10, and includes a pumping unit 12 positioned in a well 14. Well 14 is defined by a wellbore 16 which traverses a number of subterranean zones or horizons, including a production zone 18 and a discharge zone 20. In general, production zone 18 comprises geological formations containing fluids, such as oil, condensate, gas and water. Discharge zone 20 comprises earthen formations appropriate for the discharge or injection of non-production fluids, such as water. It should be noted that while in the embodiment illustrated in FIG. 2, system 10 is employed in a well wherein production zone 18 lies nearer the earth's surface than discharge zone 20, system 10 may be equally well employed in formations wherein the reverse is true. In general, pumping system 10 may be used in vertical, inclined and horizontal wellbores having one or more production zones and one or more discharge zones in various physical configurations.

Wellbore 16 is lined by a casing 22 in which system 10 is deployed. Casing 22 is, in turn traversed by production perforations 24 adjacent to production zone 18, and by discharge perforations 26, adjacent to discharge zone 20. In operation, wellbore fluids, including production fluids and non-production fluids in mixture, enter into wellbore 16 through production perforations 24. System 10 operates to separate the wellbore fluids into production and non-production fluids, reinjecting the non-production fluids into discharge zone 20, and transferring production fluids through fluid flow paths defined within system 10 to a collection point above the earth's surface.

Referring now more particularly to a preferred configuration of pumping unit 12, as illustrated in FIG. 2, unit 12 preferably includes a series of modular components assembled into a submersible unit. In the embodiment illustrated in FIG. 2, pumping unit 12 includes a first pump 28, a drive motor 30, a second pump 32 and a fluid separator 34. Also as illustrated in FIG. 2, pumping unit 12 includes a connection module 36 and a pair of motor protectors 38 and 40. A fluid conduit 42 is coupled to pump 28 to transmit production fluids from pump 28 to a location above the earth's surface, as indicated by reference numeral 44. Another transfer conduit 46 is coupled to pump 32 to transmit non-production fluids to a location adjacent to discharge zone 20. Conduit 46 traverses an isolation packer 48 which effectively isolates fluids and pressure adjacent to discharge zone 20 from fluids entering through production perforations 24.

Pump 28, which in the illustrated embodiments functions as a production pump, and pump 32, which functions as an injection pump, may be of any suitable type, such as centrifugal pumps available commercially from Reda of Bartlesville, Okla. Pump 28 has inlet or intake apertures 50 through which pump 28 draws fluids to be transferred to the

earth's surface. Production conduit 42 is coupled to the outlet of pump 28, and may comprise any suitable type of conduit, such as coil tubing.

Motor 30 is drivingly coupled to pump 28 through motor protector 38. Motor 30 is preferably a submersible polyphase electric motor coupled to an electrical power supply above the well (not represented) via a power supply and control cable 52. Cable 52 extends through wellbore 16 from the earth's surface and is electrically coupled to motor 30 through connection module 36, as described more fully below. It should be noted, however, that for certain aspects of the structure and technique described herein, motor 30 may be any suitable type of prime mover, such as a single-phase electric motor, a hydraulic motor, and so forth. In the embodiment illustrated in FIG. 2, motor 30 is designed to drive components on either end thereof. Accordingly, motor 30 is coupled to pump 28 through motor protector 38 by means of a drive shaft disposed within connection module 36, as described more fully below, as well as to second pump 32 through a series of drive shafts traversing separator 34 and motor protector 40. Motor protectors 38 and 40 provide isolation of motor 30 from well fluid entering pump 28 and separator 34 in a manner well known in the art.

In the presently preferred embodiment illustrated, separator 34 includes drive train components for transmitting torque between driving and driven components of pumping unit 12, such as from motor 30 to pump 32. Separator 34 may therefore be physically interposed between such components. Separator 34 preferably includes hydrocyclone separating devices which receive fluid from wellbore 16 through a series of intake apertures 54, and express production fluids through a series of discharge apertures 56. Separator 34 also discharges non-production fluids directly to second pump 32, which forces the non-production fluids into discharge zone 20 via discharge perforations 26.

In the preferred embodiment illustrated, fluid flow paths are defined between the components of pumping unit 12 by a series of adjustable shrouds as well as by a passageway defined through connection module 36. In particular, a first shroud 58 is sealingly disposed about unit 12 from an upper portion of separator 34 to a central portion of connection module 36. A second or upper shroud 60 is sealingly disposed about unit 12 from a central portion of connection module 36 to a lower portion of production pump 28. Shrouds 58 and 60 surround adjacent sections of pumping unit 12 to define annular fluid flow paths 62 and 63, respectively. Fluid flow path 62 directs a fluid flow from discharge apertures 56 of separator 34 upwardly around motor 30, and into a fluid passage 64 defined within connection module 36. Fluid exits fluid passage 64 of connection module 36 and enters upper flow path 63 which directs the fluid to inlet apertures 50 of production pump 28. As described more fully below, this preferred structure permits fluid to be transferred between the components of pumping unit 12 in a sealed manner without the use of separate piping. Moreover, the fluid flow directed by shrouds 58 and 60 aids in convectively cooling the system, particularly motor 30. Also, connection module 36 permits cable 52 to be electrically coupled to motor 30 without traversing a shroud wall. As also described more fully below, shrouds 58 and 60 are preferably extensible and contractible with respect to portions of pumping unit 12 over which the shrouds extend, thereby permitting relative expansion and contraction of the shrouds and of the pumping unit components while maintaining the desired seal defining fluid paths 62 and 63.

In operation, motor 30 receives electrical power through cable 52 and drives pump 28 through connection module 36

and motor protector **38**. Motor **30** also drives pump **32** through motor protector **40** and separator **34**. Production fluid extracted from wellbore fluids in separator **34** is directed through a fluid flow path defined by lower shroud **58**, fluid passage **64** of connection module **36**, and upper shroud **60** to enter into intake apertures **50** of pump **28**. The fluids are transferred by pump **28** through production conduit **42** to a collection point (not represented) above the earth's surface **44**. Non-production fluids separated from the wellbore fluids within separator **34** are transferred to pump **32** from which they are expelled via discharge conduit **46**.

As will be appreciated by those skilled in the art, the configuration of pumping system **10** illustrated in FIG. 2 may be referred to as a "pull through" system. In such systems, the separator is positioned upstream or on the suction side of an injection pump, such as pump **32**. The injection pump therefore draws flow through the separator and expels non-production fluids into a section of the wellbore adjacent to the discharge zone. Separator **34** may also be assembled in pumping systems configured as "push through" systems, wherein wellbore fluids are drawn directly into a first pump and expressed from the pump into the separator.

As will also be appreciated by those skilled in the art, while a single drive motor may be employed in pumping system **10** as shown in FIG. 2, the system may be alternatively configured with more than one drive motor as illustrated in FIG. 3. In particular, FIG. 3 illustrates a section of the pumping system represented in FIG. 2 between upper motor protector **38** and lower motor protector **40**. Other system components not illustrated in FIG. 3 may be substantially the same as those shown in FIG. 2.

In the alternative embodiment illustrated in FIG. 3, a first motor **30A** is provided for driving a first pump (see pump **28** in FIG. 2), while a second motor **30B** is provided for driving a second pump (see pump **32** in FIG. 2). Upper motor **30A** drives through an upper connection module **36A** and a motor protector **38** in manner similar to that described above with reference to FIG. 2. Lower motor **30** drives through a motor protector **40** and additional system components disposed below motor protector **40** as described above with reference to FIG. 2. A lower shroud **58B** is provided about lower components of the pumping unit, including lower motor **30B**, to direct fluid upwardly about motor **30B** to a lower connection module **36B**. Connection module **36B** includes a fluid passage **64B** through which fluid flowing upwardly is conveyed to an intermediate shroud **58A**. Intermediate shroud **58A** surrounds upper motor **30A** and conveys fluid from lower connection module **36B** to upper connection module **36A**. Connection module **36A** includes a fluid passage **64A** which directs fluid from shroud **58A** upwardly to an upper shroud **60**. As described above with reference to FIG. 2, upper shroud **60** directs fluid upwardly from connection module **36A** toward a production pump.

The sealed connections between shrouds **58A**, **58B** and **60** may be substantially identical to those about shrouds **58** and **60** of FIG. 2, as described more fully below. Also, each shroud is preferably constructed as an extensible structure to permit thermal expansion and contraction of both the shrouds and pumping unit **12**. Moreover, each connection module **36A** and **36B** includes a recess for receiving a respective power cable **52A** and **52B** for transmitting electrical power to motors **30A** and **30B**, respectively. It should be noted, however, that in the configuration illustrated in FIG. 3, no mechanical transmission components need traverse lower connection module **36B**, as lower motor **30B** drives directly through motor protector **40** in a single direction.

FIGS. 4 through 8 represent exemplary internal configurations of drive-through separators for use in submergible fluid pumping systems in accordance with certain aspects of the present technique. As illustrated in FIGS. 4 and 5, separator **34** includes a housing **66** having a side wall **68** terminating in an upper attachment flange **70** and a lower attachment flange **72**. Flanges **70** and **72** permit separator **34** to be secured in a modular fashion in pumping unit **12** as summarized above. A support or interface plate **74** is positioned radially within side wall **68** adjacent to flange **70**. A similar support or interface plate **76** is positioned within side wall **68** adjacent to lower flange **72**. One or more separators **78**, such as hydrocyclone separators as shown, are provided within housing **66**.

Separator **78** may be of a generally known configuration, including an inlet **80**, a production outlet **82**, and a non-production outlet **84**. In the embodiment illustrated in FIGS. 4 and 5, production outlet **82** is coupled to a production port **86** provided in interface plate **74**. An inlet port **88** is formed in side wall **68** to permit wellbore fluids to enter into housing **66**. In the embodiment of FIGS. 4 and 5, non-production outlet **84** is plumbed through a non-production port **90** in interface plate **76**. In operation, wellbore fluids enter housing **66** through inlet port **88** and are channeled through hydrocyclone inlet **80** to be separated into production and non-production fluids. Production fluids are then transmitted through outlet **82** and, thereby, through production port **86**. Non-production fluids are routed through outlet **84** and exit housing **66** through non-production port **90**. A fixed or variable orifice **92** may be provided in outlet **84** to provide back pressure for operation of hydrocyclone separator **78**. It should be noted that where several separators are provided within housing **66**, these may be plumbed in series or in parallel. Where multiple separators are provided in parallel, a fixed or variable orifice **92** if preferably disposed about a common outlet or header.

In addition to hydrocyclone separator **78**, separator **34** includes one or more elements of a power drive train for transmitting torque from the drive motor to one or more pumps. In the embodiment illustrated in FIG. 4, a drive shaft **94** is disposed through housing **66**. Drive shaft **94** is supported within separator **34** by bearings **96** and **98** lodged in interface plates **74** and **76**, respectively. As will be appreciated by those skilled in the art, ends of shaft **94** may be keyed, splined or otherwise configured for interfacing in a modular fashion with other components of the pumping system upon installation of separator **34**, as described more fully below. Thus, for example, where separator **34** is to be incorporated in the configuration illustrated in FIG. 2, a lower end of shaft **94** will be configured to interface with a drive train through pump **32**, while an upper end of shaft **94** will be configured to interface with a similar drive train through motor protector **42**.

Shaft **94** may be positioned coaxially within housing **66** or, as illustrated in FIGS. 4, 5 and 6, may extend generally parallel to an axis of housing **66**, but offset from the housing axis. In the latter case, housing **66** may itself be coupled to adjacent components of pumping unit **12** via offset flanges or similar interface hardware (not shown).

FIG. 6 illustrates an alternative configuration of separator **34**. In the embodiment of FIG. 6, hydrocyclone separator **78** is ported through side wall **68**, and lower interface plate **76** is configured to receive wellbore fluids. One or a series of inlet ports **100** are formed in interface plate **76** to permit separator **34** to receive fluids, such as from an upstream pump **32** in a push-through system configuration. In the embodiment of FIG. 6, non-production fluids are ejected

through side wall 68. As mentioned with regard to FIG. 4, although a single hydrocyclone separator 78 is illustrated within separator 34 of FIG. 6, multiple hydrocyclone separators may be provided and interconnected either in series or in parallel. A power transmission drive train, including shaft 94, extends through separator 34 and is supported by bearings 96 and 98 fitted to interface plates 74 and 76, respectively.

It should be noted that, while in the present description reference is made to upper and lower flanges, and upper and lower interface plates of separator 34, as will be appreciated by those skilled in the art, separator 34 may be oriented in a pumping system either in the position illustrated in FIGS. 4 and 6, or in an inverted position. The position selected will typically depend upon the relative position of the pumps within the pumping system and the flow paths desired by the well operator.

As mentioned above, separator 34 may be configured to include a number of hydrocyclone separators 78 positioned with a single unit. Also, the elements of the power transmission drive train traversing separator 34 may be positioned concentrically with the housing. FIGS. 7 and 8 illustrate a separator of this type. Specifically, as shown in FIG. 7, separator 34 includes a housing 102 in which a top end plate 104 and a bottom end plate 106 are positioned. A series of intermediate plates or manifolds 108 are secured within housing 102, to define interior chambers 110. Inlet ports 112 are formed through side wall 68 of housing 102 to permit wellbore fluids to be drawn into separator 34. Where such ports 112 are provided for each chamber 110, pressure equalizing ports 114 are preferably formed in intermediate plates 108 to permit the exchange of sufficient fluid between the chambers to equalize pressure within the separator. Each end plate and intermediate plate is plumbed to one or more hydrocyclone separators 78.

As in the previous embodiments, each hydrocyclone separator 78 includes an inlet 80, a production outlet 82, and a non-production outlet 84. In the embodiment illustrated in FIGS. 7 and 8, production outlets 82 are plumbed through a common production header 116 which terminates in top end plate 104. Similarly, non-production outlets 84 of the hydrocyclone separators are plumbed through a common non-production discharge header 118, which terminates in bottom end plate 106. A ported production outlet 120 is formed in plate 104 to receive flow from production header 116. Similarly, a ported non-production fluid outlet 122 is formed in end plate 106. In operation, wellbore fluids are drawn into separator 34 via intake ports 112 to be separated into production and non-production fluids by hydrocyclone separators 78. Production fluids are then transferred upwardly through header 116 to exit separator 34 through port 120. Non-production fluids flow from hydrocyclone separators 78 through non-production header 118 to exit separator 34 through port 122.

Shaft 94 extends through housing 102, being supported by both end plates 104 and 106 and intermediate plates 108. As shown in FIG. 7, for separators having a particularly long housing 102, multiple bearing sets may be provided along the length of the housing for supporting shaft 94 in rotation. In the specific embodiment illustrated in FIG. 7, bearings 124 are provided in the end plates as well as in intermediate plates along separator 34. Because hydrocyclone separators 78 are positioned in a radial distribution within housing 102 (see FIG. 8), shaft 94 is conveniently provided along a central axis 126 of housing 122. As summarized above with respect to FIGS. 4 through 6, ends of shaft 94 are formed to interface with drive components of pumping unit 12, to

transmit torque between the submersible drive motor and a pump coupled to the drive motor through the intermediary of separator 34.

While the separator illustrated in FIG. 7 is particularly well suited to pull-through separation systems, it will be appreciated by those skilled in the art that the unique features of the separator may be adapted for use in push-through systems. Accordingly, an inlet port for wellbore fluids may be provided in either upper plate 104 or lower plate 106. Outlets for routing non-production fluids from the hydrocyclone separators may then be ported through side wall 68, similar to the arrangement illustrated in FIG. 6, permitting non-production fluids to be injected directly into a discharge zone adjacent to the separator.

It should also be noted that the embodiment of separator 34 illustrated in FIGS. 7 and 8 may be subject to a variety of alternative configurations. For example, in a presently preferred configuration, a series of hydrocyclone separators are positioned on one side of housing 122. Sixteen such hydrocyclone separators are embodied in a single unitary device. A cable for supplying electrical energy to a submersible motor may be positioned on the outside of the pumping system, on the same side as the hydrocyclone separators. Because in a typical well application the submersible pumping unit has much less clearance within the wellbore than illustrated diagrammatically in the Figures, the presence of the cable adjacent to the pumping system urges separator ports provided in the housing away from the well casing, facilitating flow into the separator. Other alternative configurations may be envisaged by those skilled in the art depending upon wellbore clearances, orientations, production and rejection rates, and so forth. Moreover, dynamic separating units may be employed in place of the hydrocyclone separators described above.

FIGS. 9 and 10 illustrate the presently preferred configurations for upper and lower ends of separator 34 when coupled to adjacent components of pumping system 10. In particular, as illustrated in FIG. 9, the upper end of separator 34 includes an intake section, designated generally by the reference numeral 128, and a transfer section 130. In the illustrated embodiment, intake section 128 serves to draw wellbore fluids into the separator, while transfer section 130 serves to transmit production fluids upwardly in the pumping unit toward production pump 28. Specifically, side wall 68 of intake section 128 forms an intake chamber 132 which is in fluid communication with wellbore fluids external to separator 34 via intake apertures 54. Wellbore fluids enter into intake chamber 132 through apertures 54 as indicated by arrows 134. A series of shaft sections 136 are coupled to shaft 94 of separator 34 to transmit torque to shaft 94 from motor 30, as illustrated in FIG. 2 (or motor 30B as illustrated in FIG. 3). The shaft sections are coupled to one another via couplings 138 in a manner generally known in the art. Bores 140 are formed through the internal components of both the intake section 128 and transfer section 130 to accommodate shaft 94 and shaft sections 136.

As described above with respect to FIGS. 7 and 8, a production header 116 carries production fluids separated from wellbore fluids in separator 34 to a production outlet 120. Production header 116 and production outlet 120 are separated from wellbore fluids entering into intake chamber 132 by a seal plate 142. Seal plate 142 is sealed within the inner periphery of side wall 68 as illustrated in FIG. 9. A mechanical seal assembly 144 is secured to a lower face of seal plate 142, and surrounds and seals against shaft 94 to isolate wellbore fluids within intake chamber 132 from production fluids passing through production outlet 120 and



discharge apertures 56. Seal assembly 144 is preferably of a conventional design available commercially from Flowserve of Tulsa, Okla. Below seal assembly 144, and within intake chamber 132, an impeller 146 is secured to shaft 94 and rotates with shaft 94. Impeller 146 forces circulation of wellbore fluids entering into intake chamber 132 to promote convective cooling of seal assembly 144. From intake chamber 132, wellbore fluids are drawn through the individual separator units included in separator 34 as described above.

FIG. 10 illustrates the internal configuration of the lower end of separator 34 in accordance with the presently preferred embodiment. As shown in FIG. 10, shaft 94 passes through end plate 106 in which discharge header 118 is provided. Discharge header 118 is sealed to non-production fluid outlet 122 for transferring non-production fluids in a downward direction for injection into an appropriate subterranean discharge zone. A lower end of shaft 94 is sealed from the upper end of second pump 32 by a seal plate 150, similar to seal plate 142 described above with reference to FIG. 9. Seal plate 150 is sealed to the inner periphery of side wall 68 of separator 34 to form a seal chamber 152 between end plate 106 and seal plate 150. A series of apertures 154 are formed through side wall 68 to permit wellbore fluids to enter into seal chamber 152. A seal assembly 156 is secured to an upper face of seal plate 150 and seals against rotating shaft 94 to isolate seal chamber 152 from the intake side of pump 32. Seal assembly 156 is preferably substantially similar to seal assembly 144 described above. An impeller 158 is secured to shaft 94 and rotates with shaft 94 to circulate wellbore fluids within seal chamber 152 to promote convective cooling of seal assembly 156.

As described generally above, the fluid directing shrouds included in the preferably preferred embodiment of pumping system 10 are extensible and contractible to permit relative extension and contraction of both the shrouds and portions of pumping unit 12 over which the shrouds extend during operation, while maintaining a fluid-tight seal around the annular flow paths defined by the shrouds. While various configurations may be envisioned by those skilled in the art to permit the shrouds to seal against pumping unit 12 while allowing for thermal expansion and contraction, in presently preferred embodiments one or both ends of the shrouds may be fixedly secured to components of pumping unit 12 and a sliding seal provided at appropriate positions along the length of the shroud to accommodate expansion and contraction.

FIGS. 9 and 11 illustrate two presently preferred arrangements for securing one end of a shroud fixedly to an element of pumping system 12. Specifically, as illustrated in FIG. 9, each shroud comprises an elongated tubular body 160 extending along a portion of pumping unit 12 to define an annular flow path, such as indicated at reference numeral 62 in FIG. 9. As shown in FIG. 9, shroud 58 is secured to an upper end of transfer section 130 of separator 34. To sealably secure the shroud to separator 34, a first sealing land 162 is formed about the lower outer periphery of shroud body 160, while a similar sealing land 164 is formed about the outer periphery of transfer section 130. A coupling ring 166 is secured about both sealing lands to hold body 160 and an upper end of transfer section 130 in close abutment. In the illustrated embodiment, coupling ring 166 serves both to maintain the shroud body 160 in a desired position with respect to the pumping unit component, as well as to seal the fluid flow paths defined within the component and the shroud to one another. Accordingly, adjacent to each sealing land 162 and 164, annular grooves 168 and 170 are formed. Within an inner periphery of coupling ring 166, seal grooves

172 are formed, and sealing members, such as O-rings 174 are disposed within the grooves.

During assembly, coupling ring 160 is placed over land 164 to compress sealing member 174 slightly to form a fluid-tight seal between land 164 and the inner periphery of coupling ring 166. Shroud body 160 is then inserted into the position illustrated in FIG. 9, forming a fluid-tight seal between land 162 and the upper sealing member 174. A series of fasteners 176 are secured in apertures around the upper and lower periphery of coupling ring 166 and enter into grooves 168 and 170 to maintain the elements in the sealed position illustrated. In a presently preferred embodiment, a series of 14 set screws 176 are secured in corresponding apertures about upper and lower ends of coupling ring 166.

As illustrated in FIG. 11, in accordance with another preferred arrangement a flange-type structure is used to secure a shroud end to a component of pumping unit 12. FIG. 11 illustrates an upper end of shroud 60 which extends about motor protector 38 and directs fluid to upper pump 28 via pump intake apertures 50. Shroud 60 is secured to a lower section of pump 28 by a flanged coupling structure as follows. A peripheral flange groove 178 is formed about the lower end of pump 28 adjacent to intake apertures 50. A flange 180 is fitted within groove 178 and an annular flanged coupling 182 is secured to flange 180 by means of fasteners 184. Flanged coupling 182 is sealed about pump 28 by means of a seal member 186 disposed within an annular groove 188 formed in a peripheral face of pump 28.

A coupling ring 166 is secured about a lower end of flanged coupling 182 to hold an upper end of shroud 60 in place and to seal the annular fluid path 63 within shroud 60 in fluid communication with inlet apertures 50. Coupling ring 166 is preferably substantially similar to that described above with respect to FIG. 9. Accordingly, to permit coupling ring 166 to be mechanically secured to flanged coupling 182 and to an upper end of shroud 60, coupling 182 includes a sealing land 162 and an annular groove 168, while the upper end of shroud 60 includes a similar sealing land 164 and annular groove 170. A pair of seal grooves 172 are formed in the inner face of coupling ring 166, and a seal 174 is disposed in each groove. Coupling ring 166 is fitted about sealing land 162, and shroud 60 is fitted into coupling ring 166 to compress seals 174 and thereby to seal coupling ring 166 about both flanged coupling 182 and shroud 60. Fasteners 176, such as a series of set screws, are secured within apertures about the periphery of coupling ring 166, entering into grooves 168 and 170 to mechanically hold shroud 60 in place below flanged coupling 182.

It should be noted that in addition to the coupling ring and flange structures described above, those skilled in the art may envision alternative arrangements for sealably securing ends of the extensible shrouds to components of pumping unit 12. In particular, threaded ends of the shroud body and of mating coupling ring elements may be provided for mechanically securing the shrouds in place, while maintaining the desired fluid-tight seal. It has been found that the preferred embodiments described above, however, facilitate field installation of the shrouds, while maintaining the desired nominal lengths of the shroud sections for thermal expansion and contraction as described below.

Where pumping system 10 includes particularly long shroud sections, as illustrated in the case of shroud 58 in FIG. 2, the shroud body may comprise a plurality of tubular sections joined end-to-end as illustrated in FIG. 12. In the presently preferred embodiment, shroud lengths of over 20

feet are divided into tubular sections of this type to facilitate the manufacture, transport and installation. As illustrated in FIG. 12, tubular sections 190 and 192 of a shroud may be joined to one another by means of a coupling ring system of the type described above. Accordingly, each shroud section 190 and 192 presents an outer peripheral sealing land 162 and 164, respectively. A coupling ring 166 of the type described above with reference to FIGS. 9 and 11, is fitted about the shroud sections and includes seals 174 fitted within inner peripheral annular grooves 172. Annular grooves 168 and 170 are formed adjacent to sealing lands 162 and 164 and receive fasteners, such as set screws 176, for securing the shroud sections to one another.

As mentioned above, each shroud is extendible and contractible with thermal expansion of both the shrouds and the pumping unit to maintain a fluid-tight seal about the flow paths defined between the shrouds and the pumping unit. FIG. 13 illustrates two presently preferred arrangements for permitting such thermal expansion and contraction. As shown in FIG. 13, a shroud, such as upper shroud 60, may establish a fluid-tight seal about a component of pumping unit 12, such as connection module 36 as shown in FIG. 13. In general, as described in greater detail below, connection module 36 includes a body 194 traversed by a bore 196 which permits a drive shaft 198 to be rotatably positioned within and to conduct torque through module 36 from motor 30 to pump 28 (see FIG. 2). A lower end 200 of shroud 60 is fitted about body 194 and provides a sliding seal with the outer periphery of the body. Accordingly, an inner annular sealing land or region 202 is formed about lower end 200 of shroud 60, while a similar sealing land or region 204 is formed about the outer periphery of body 194. A seal groove 206 is formed within sealing region 204 and an annular fluid seal member 208 is disposed therein.

When shroud 60 is fitted to body 194, seal member 208 is compressed and sealing regions 202 and 204 are brought into mutually facing relation with one another to seal fluid path 63 within shroud 60 in fluid communication with fluid passage 64 formed in connection module 36. As shroud 60 and the elements contained within shroud 60 expand and contract due to temperature variations within the wellbore, thermal expansion and contraction is accommodated by relative movement of sealing regions 202 and 204 with respect to one another. In particular, as shown in FIG. 13, shroud 60 is assembled to position lower end 200 thereof in a nominal position 210. However, the shroud and the pumping unit components may expand and contract during assembly, transport and use between predetermined lengths wherein lower end 200 is located within a maximal upper position 212 and a maximal lower position 214. As will be appreciated by those skilled in the art, the lengths and positions of sealing regions 202 and 204 are designed to maintain sealing engagement of shroud 60 about body 194 throughout the anticipated thermal expansion and contraction cycles of the equipment. In general, the lengths and locations of regions 202 and 204 will depend upon the relative lengths of the shroud and upon the pumping unit components contained within the shroud, the thermal expansion coefficients of each, and the anticipated temperature range to which the elements will be subjected.

FIG. 13 also illustrates another preferred configuration for permitting relative thermal expansion and contraction of a shroud and pumping unit components. Specifically, as illustrated in the lower portion of FIG. 13, shroud 58 is secured to a lower portion of connection module 36 by means of a flanged coupling structure similar to that described above with respect to FIG. 11. Specifically, a flange 180 is fitted

within a flange groove 178 formed within body 194 of connection module 36. A flange coupling 216 is secured to flange 180 by means of fasteners 184. A fluid-tight seal is established between body 194 and flange coupling 216 by a seal 186 fitted within a groove 188 formed in body 194.

Flange coupling 216 includes an open lower end for receiving an upper end of shroud 58. An inner peripheral sealing land or region 218 is formed within coupling 216, while a facing sealing land or region 220 is formed about the outer periphery of shroud 58. A seal groove 222 is formed about the outer periphery of shroud 58, and a sealing member 224 is fitted within the groove. When shroud 58 is fitted within coupling 216, regions 218 and 220 are brought into mutually facing relation and sealing member 224 is compressed. A fluid-tight seal is thus established between sealing regions 218 and 220 which is maintained throughout expansion and contraction of the shroud and of the components covered by the shroud during cycling. Accordingly, upon installation, shroud 58 will extend into coupling 216 in a nominal position as indicated by reference numeral 226. During expansion and contraction cycles of the equipment, shroud 58 and coupling 216 will move relative to one another between a maximal upper position 228 and a maximal lower position 230. As described above with respect to sealing regions 202 and 204, the length and amount of engagement between sealing regions 218 and 220 will depend upon the relative lengths of the shroud and pumping unit components covered by the shroud, as well as upon their coefficients of thermal expansion and the anticipated temperature variations to which the equipment will be subjected during use.

As mentioned above, in the preferred embodiment illustrated, connection module 36 permits a fluid flow path to be established within pumping system 10, while facilitating electrical connection of cable 52 to motor 30 (or cables 52A and 52B to motors 30A and 30B). FIG. 13 illustrates a presently preferred embodiment of connection module 36.

Thus, connection module 36 includes a body 194 through which a bore 196 is formed for permitting a power transmission shaft 198 to be connected between modular components on either side of connection module 36. As installed in the particular arrangement illustrated in FIG. 13, connection module 36 extends between motor 30 and motor protector 38, the latter component being in turn coupled to production pump 28. However, it should be understood that connection module 36 may be secured between a motor 30 and other components of pumping system 10 as desired depending upon the particular system configuration. Also as described above, connection module 36 preferably includes features for coupling fluid conduits, such as shrouds 58 and 60 in fluid communication with an internal passage 64 traversing connection module 36. In the embodiment of FIG. 13, such features include a sliding sealing arrangement formed by sealing region 204 and seal 208, and a fixed flange arrangement including groove 178, flange 180, and seal 186. Moreover, the fluid directing features may be provided in a single unitary structure as illustrated in FIG. 13, or may be formed in separable modular components which are assembled to form a unitary structure.

As illustrated in FIG. 13, fluid passage 64 preferably includes an elongated central portion 232 and a pair of outwardly angled portions 234 and 236 formed within upper and lower interface ends 238 and 240, respectively, of connection module 36. This preferred form of fluid passage 64 permits the outer dimensions of connection module 36 to be maintained within a compact envelope as needed to fit

within wellbore 16, while directing fluid to internal fluid paths defined by the adjacent shrouds. Moreover, while a single fluid passage 64 may be provided in connection module 36, a plurality of such passages are preferably radially spaced within body 194 as illustrated in FIG. 14. Each passage is separated by an internal partition 242 formed within body 194.

In addition to fluid passage 64, connection module 36 includes a recess 242 for receiving cable 52. As will be appreciated by those skilled in the art, because power and data signals are typically transmitted via a multi-conductor cable 52, electrical connection must be made between the submersible motor 30 and power supply and data control and monitoring equipment above the earth's surface. In the embodiment illustrated in FIGS. 13 and 14, recess 244 serves to receive a terminal portion 246 of cable 52 to which a terminal plug 248 is attached. Cable 52 and terminal plug 248 are preferably of known design. Moreover, in the presently preferred embodiment, connection module 36 includes an electrical connector 250 which interfaces with plug 248 to convey power to motor 30. Connector 250 is provided in a socket 252 which is equipped with a peripheral seal 254 for sealing conductors extending from plug 248 and connector 250. A passageway 256 is formed in body 194 to accommodate conductors (not illustrated in FIG. 13) for conveying electrical power to motor 30 from connector 250.

As will be appreciated by those skilled in the art, connection module 36 thus serves multiple functions within pumping unit 12. Specifically, module 36 facilitates transfer of fluids between the system components, particularly between fluid paths defined by shroud 58 and 60. Moreover, module 36 enables components on either side thereof to be driven via a power transmission shaft 198. Finally, connection module 36 serves as a motor head for completing current carrying paths between a power supply cable and a submersible motor included within pumping unit 12 without the need to traverse a fluid shroud extending around the system components.

While the invention may be susceptible to various modifications and alternative forms, specific embodiments have been shown by way of example in the drawings and have been described in detail herein. However, it should be understood that the invention is not intended to be limited to the particular forms disclosed. Rather, the invention is to cover all modifications, equivalents, and alternatives falling within the spirit and scope of the invention as defined by the following appended claims. For example, while the connection module described above may advantageously be used in pumping systems including a fluid separator and a plurality of fluid transfer shrouds, it is equally applicable in pumping systems having other configurations and components, including other fluid transfer hardware, such as non-adjustable shrouds, conduits, and the like.

What is claimed is:

1. A connecting module for a submersible pumping system, the system comprising a plurality of components including a submersible electric motor coupled to a pump, the pumping system being submersible with a well to pump fluids from the well, the connecting module comprising:

a body configured to be coupled adjacent to the motor within the pumping system;

a fluid passage formed through at least a portion of the body for channeling a flow of fluid to the pump;

a recess formed in an outer periphery of the body for receiving at least one conductor for transmitting electrical power or data to the motor from a location outside the well; and

a drive shaft extending through at least a portion of the body for transmitting torque between the motor and the pump.

2. The connecting module of claim 1, wherein the body includes first and second ends and a peripheral outer wall, and wherein the fluid passage extends through the outer wall adjacent to the first and second ends.

3. The connecting module of claim 1, wherein the body includes first and second interface ends and a central section extending between the interface ends, and wherein the fluid passage defined by first and second interface passages formed in the first and second interface ends, respectively, and a connecting passage extending through the central section in fluid communication with the first and second interface passages.

4. The connecting module of claim 3, further comprising an electrical connector for establishing an electrical current carrying path between the electric motor and the at least one conductor, the connector being disposed at least partially in the first interface end.

5. The connecting module of claim 3, wherein the first and second interface ends include first and second seals, respectively, for sealingly securing the connecting module between the electric motor and a second component of the pumping system.

6. The connecting module of claim 1, further comprising an electrical connector for establishing electrical current carrying paths between the electric motor and power conductors extending from the earth's surface.

7. The connecting module of claim 1, wherein the body is configured to sealingly receive an end of at least one fluid conducting shroud for placing the fluid passage in sealed fluid communication with a fluid flow region defined between the at least one shroud and at least one component of the pumping system.

8. A motor head connecting module for use in a submersible pumping system, the pumping system comprising a plurality of interconnected components including a pump for raising wellbore fluids from a well to the earth's surface, a submersible electric motor coupled to the pump for driving the pump, the pumping system further including a conduit coupled to the pump for transferring fluids from the pump, and a power cable coupled to the motor for supplying electrical power to the motor, the connecting module comprising:

a body configured for attachment directly and sealingly to the electric motor and to a second component of the pumping system;

a fluid passage extending at least partially through the body for conveying fluid from a first location adjacent to the motor to a second location distal from the motor; and

an electrical connector disposed in the body and configured to cooperate with the power cable and to transmit electrical power from the power cable to the motor.

9. The connecting module of claim 8, wherein the body includes first and second interface ends and a central portion extending between the interface ends, and wherein the electrical connector is disposed in the first interface end.

10. The connecting module of claim 9, wherein the first interface end is configured for attachment to the electric motor.

11. The connecting module of claim 9, wherein the first and second interface ends include first and second interface passages, respectively, and the central portion includes a connecting passage extending therebetween, and wherein the fluid passage defined by first and second interface passages and the connecting passage.

12. The connecting module of claim 9, wherein the body is configured to sealingly receive an end of at least one fluid conducting shroud for placing the fluid passage in sealed fluid communication with a fluid flow region defined between the at least one shroud and the electric motor.

13. The connecting module of claim 12, wherein the body includes an annular sealing land on an outer periphery thereof, the sealing land being configured to receive and seal the end of the at least one fluid conducting shroud.

14. The connecting module of claim 12, wherein the body is configured to sealingly receive an end of first and second fluid conducting shrouds for placing the fluid passage in sealed fluid communication with first and second fluid flow regions defined within the first and second shrouds, respectively.

15. A submergible pumping system for raising fluids from a well, the system comprising:

- a submergible pump having an inlet and an outlet;
- a submergible electric motor operatively coupled to the pump;
- a fluid conduit for conveying fluid from the pump outlet to a location above the earth's surface;
- a power cable coupled to the motor for supplying electric power to the motor;
- a connection module disposed between the pump and the motor, the connection module including a fluid passage for directing fluid from a first location adjacent to the motor to a second location distal from the motor, and a recess for receiving the power cable;
- means for directing fluid from the second location to the pump inlet; and
- a shroud for directing a flow of fluid around at least a portion of the motor and into the fluid passage at the first location.

16. The system of claim 15, wherein the connection module includes an electrical connector for electrically coupling the power cable to the motor.

17. The system of claim 15, wherein the means for directing fluid includes a second shroud extending between the connection module and the pump.

18. The system of claim 15, further comprising a fluid separator for separating production fluid from non-production fluid, and wherein the shroud directs production fluid from the separator to the first location.

19. The system of claim 18, further comprising an injection pump for directing non-production fluid from the separator to an injection zone of the well.

20. The system of claim 19, further comprising a second motor coupled to the injection pump, and a second connection module disposed adjacent to the second motor and

having a fluid passage for directing a flow of production fluid from a location adjacent to the second motor to a location distal from the second motor, and a recess for receiving a power cable for supplying electrical power to the second motor.

21. A method for directing flow of fluid in a submergible pumping system, the pumping system including a submergible pump having an inlet and an outlet, a submergible electric motor coupled to the pump, a conduit for directing fluid from the pump outlet to a location above the earth's surface, and a power cable for conducting electrical power to the motor, the method comprising the steps of:

- (a) coupling a connection module between the motor and the pump, the connection module including a fluid passage, a shaft for transmitting torque from the motor to the pump, and an electrical connector coupled to the power supply cable;
- (b) coupling a shroud around at least a portion of the motor to direct fluid to the fluid passage;
- (c) coupling fluid conducting means between the fluid passage and the pump inlet;
- (d) positioning the pumping system at least partially in fluids within a well; and
- (e) energizing the motor via the power cable to circulate fluid from the well through a fluid flow path defined by the shroud, the fluid passage, the fluid conducting means, the pump and the fluid conduit.

22. The method of claim 21, wherein the fluid conducting means includes a second shroud disposed between the connection module and the pump inlet.

23. The method of claim 21, wherein the pumping system includes a fluid separator for separating production fluids from non-production fluids, and wherein the fluid circulated through the fluid flow path in step (e) is production fluid.

24. The method of claim 23, including the further step of injecting non-production fluid into a subterranean formation.

25. The method of claim 24, wherein the non-production fluid is injected into the subterranean formation by an injection pump included in the pumping system.

26. The method of claim 25, wherein the injection pump is driven by a second submergible motor, and the method includes the further steps of coupling a second connection module adjacent to the second submergible motor, the second connection module including a second fluid passage, and energizing the second electric motor, and wherein the flow path through which the production fluid flows in step (e) includes a second shroud disposed about the second electric motor, and the second fluid passage.

\* \* \* \* \*