

No. 635,101.

Patented Oct. 17, 1899.

J. E. KENNEDY.
VALVE FOR VENTILATED SHOES.

(Application filed Dec. 16, 1898.)

(No Model.)

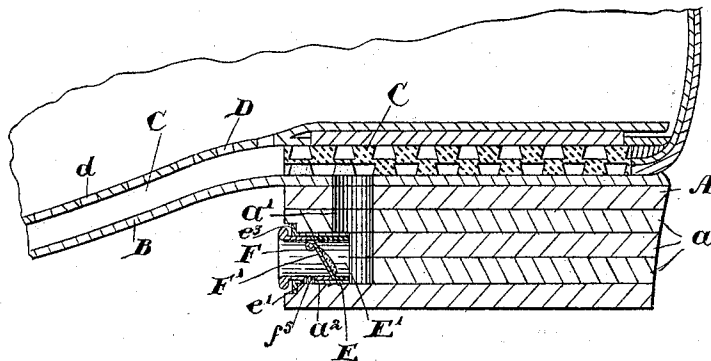

Fig. 1.

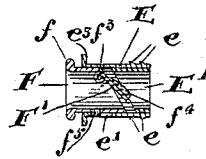

Fig. 2.

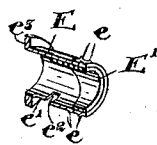

Fig. 3.

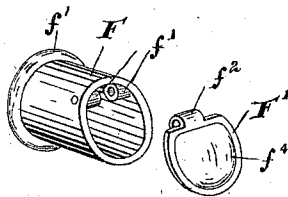

Fig. 4.

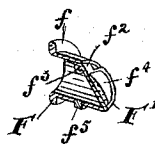

Fig. 5.

Witnesses.

H. Hennison.

C. W. Adams

Inventor.

J. E. Kennedy.

by

Fisher, Sturtevant & Co.

Attys.

UNITED STATES PATENT OFFICE.

JOHN ERNEST KENNEDY, OF MONTREAL, CANADA.

VALVE FOR VENTILATED SHOES.

SPECIFICATION forming part of Letters Patent No. 635,101, dated October 17, 1899.

Application filed December 16, 1898. Serial No. 699,505. (No model.)

To all whom it may concern:

Be it known that I, JOHN ERNEST KENNEDY, of the city and district of Montreal, in the Province of Quebec, Canada, have invented certain new and useful Improvements in Valves for Ventilated Shoes, of which the following is a specification.

My invention relates to improvements in valves for ventilated shoes; and the object of the invention is to devise a valve, automatic in its action and simple in its construction, which will effectually provide for a thorough ventilation of the foot in the boot or shoe; and it consists, essentially, of two casings, one fitting within the other, the inner one being provided at its inclined inner end with a hinged flap and the outer one having an L-shaped slot into which extends a pin from the inner casing, whereby the movement of the casing and the hinged flap may be limited and locked, as hereinafter more particularly explained.

Figure 1 is a sectional view showing my improved valve permanently closed. Fig. 2 is a longitudinal section through the casings, showing the inner casing adjusted and the hinged flap raised in position to open and close. Fig. 3 is a sectional perspective view of the outer casing. Fig. 4 is sectional perspective detail of the inner casing and flap. Fig. 5 is an exaggerated perspective detail of the inner casing and flap separated.

In the drawings like letters of reference indicate corresponding parts in each figure.

My invention is intended to be used in connection with a collapsible inner sole which operates to draw in air through a suitable orifice in the boot when the foot is raised in walking and the sole thereby permitted to expand and to force the air to rise around the foot when the foot is placed on the ground, which compresses the sole.

A is the heel of the boot; B, the sole; C, the collapsible inner sole, and D the insole. The heel A is usually comprised of several lifts a . Before the undermost lift or lifts are put on a hole a' is bored through the upper lifts and then the last lift is put on and a hole a'' is bored laterally from the front of the heel, so as to connect with the hole a' . The hole a' of course extends through the sole B to an open space in the collapsible inner sole.

Although I describe this manner of making the holes for the insertion of the valve and also describe the heel as being comprised of several lifts, it will be readily understood that the holes may be bored in any suitable way, and the heel, instead of being in lifts, may be in one piece.

E is the outer casing, which is open at each end and is provided with spicular projections e at the inner end having an incline outwardly, so that when the casing E is inserted into the hole a'' such spicular projections will hold such casing in position. The casing E is provided with a slot e' , which has a notch e'' cut at the inner end, making the slot L-shaped.

E' is a sleeve fitting within the casing E and provided with an inclined inner end.

F is the inner casing, provided with a stop-flange f , preferably with a milled edge at its outer end and at the side with a limiting-pin f^5 , which extends into the slot e' in the casing E, and when the inner casing F is pulled out and slightly turned the limiting-pin f^5 is in the notch e'' , thereby securely locking the casing F in its open position. The casing F has an inclined inner end, the incline of which corresponds to the incline of the inner end of the sleeve E'. The inner end of the casing F is also provided with hollow journal-teats f' , between which fits the hinge-boss f^2 of the flap F'. Through the journal-bosses f' and hinge-boss f^2 extends the hinge-pin f^3 .

In order to bring the stop-flange f nearly flush with the heel, I turn up a flange e^3 on the outer casing E and sink it sufficiently into the heel, leaving space enough around the flange f to insert the thumb-nail or a suitable instrument to pull out the casing F.

The flap F' is preferably provided with a weight-bulb f^4 . The inclined inner end of the sleeve E' serves as a means of limiting the throw of the valve-flap F'.

Under ordinary circumstances when the valve is open, as shown in Fig. 2, and a person in walking places his foot upon the ground he would necessarily collapse the inner sole both on the sole and heel of the boot, thereby serving to close the weighted valve-flap F' and cause the air to pass up through the perforations in the insole around the foot. Upon raising the foot the inner sole will expand,

and the suction thereby caused will draw the valve-flap inwardly, thereby opening the same, and the air will pass upwardly through the hole *a'* into the spaces of the collapsible inner sole. Upon placing the foot down again this fresh air is caused to ascend through the openings *d* around the foot. This operation is repeated continuously as long as the casing F is pulled into its outward position, and the foot is thereby kept thoroughly ventilated and consequently dry and comfortable and free from moisture or perspiration.

Should the wearer of the shoe be walking in a wet place, he can merely push in the casing F, and thereby completely close against the ingress of water or air into the shoe.

What I claim as my invention is—

1. A valve comprising an outer casing, an inner casing slidable longitudinally therein, a flap carried thereby and a fixed stop in said outer casing adapted to prevent the movement of the flap, substantially as described.

2. A valve comprising an outer casing, an inner casing slidable longitudinally within

the same, a flap pivoted to the inner end thereof and a sleeve fixed in said outer casing adapted to lock the flap against movement, substantially as described.

3. A valve comprising an outer casing, an inner casing slidable therein, bearings extending from the upper part of the inner periphery of said inner casing, a flap pivoted in said bearings and a sleeve fixed in the outer casing, substantially as described.

4. The combination with the outer casing having an L-shaped slot, of the inner casing having a flange at the outer end and an inclined inner end provided with a hinged flap and a pin extending from the inner casing into the slot in the outer casing as and for the purpose specified.

Signed at Montreal, Canada, this 12th day of December, 1898.

JOHN ERNEST KENNEDY.

Witnesses:

CLARENCE MEDLEY,
RICHARD COLLINS.