



US00D889361S

(12) **United States Design Patent**  
**Minchella**

(10) **Patent No.:** **US D889,361 S**

(45) **Date of Patent:** **\*\* Jul. 7, 2020**

- (54) **WHEEL**
- (71) Applicant: **Jaguar Land Rover Limited**, Whitley, Coventry (GB)
- (72) Inventor: **Alessio Minchella**, Whitley Coventry (GB)
- (73) Assignee: **Jaguar Land Rover Limited**, Whitley, Coventry (GB)
- (\*\*) Term: **15 Years**
- (21) Appl. No.: **29/683,816**

D725,569 S *	3/2015	Komukai .....	D12/209
D752,496 S *	3/2016	Smith .....	D12/209
D753,045 S *	4/2016	Kawaguchi .....	D12/209
D775,044 S *	12/2016	Smith .....	D12/209
D813,138 S *	3/2018	Chung .....	D12/211
D819,535 S *	6/2018	Austin .....	D12/209
D819,536 S *	6/2018	Austin .....	D12/209
D825,424 S *	8/2018	Setter .....	D12/209
D832,177 S *	10/2018	Grewer .....	D12/209
D834,485 S *	11/2018	Manzoni .....	D12/209
D836,524 S *	12/2018	Austin .....	D12/209
D848,922 S *	5/2019	Tovey .....	D12/209
D848,925 S *	5/2019	Myrberg .....	D12/209
D856,254 S *	8/2019	Melville-Brown .....	D12/209
D857,590 S *	8/2019	Setter .....	D12/209

- (22) Filed: **Mar. 15, 2019**
- (30) **Foreign Application Priority Data**

Sep. 16, 2018 (EM) ..... 005642550

- (51) **LOC (12) Cl.** ..... **12-16**
- (52) **U.S. Cl.**  
USPC ..... **D12/209**

- (58) **Field of Classification Search**  
USPC ..... D12/204–213; D21/563  
CPC .... B60B 7/00; B60B 7/02; B60B 7/04; B60B 7/01; B60B 7/06; B60B 3/02; B60B 3/04; B60B 3/06; B60B 3/10; B60B 1/00; B60B 1/08; B60B 1/10; B60B 1/12  
See application file for complete search history.

- (56) **References Cited**  
**U.S. PATENT DOCUMENTS**

D682,761 S *	5/2013	Pollmann .....	D12/209
D695,669 S *	12/2013	Pollmann .....	D12/209

\* cited by examiner

*Primary Examiner* — Stacia A Cadmus  
(74) *Attorney, Agent, or Firm* — Wood Herron & Evans LLP

- (57) **CLAIM**  
The ornamental design for a wheel, as shown and described.

**DESCRIPTION**

FIG. 1 is a front left perspective view of a wheel according to the present invention. FIG. 2 is a front view of the wheel shown in FIG. 1; and, FIG. 3 is a left side view thereof, the right side view being a mirror image thereof. The broken line showing of the rear of the rim, the bolt holes, and the center hole in the central hub area is included for the purpose of illustrating environment and forms no part of the claimed design.

**1 Claim, 3 Drawing Sheets**

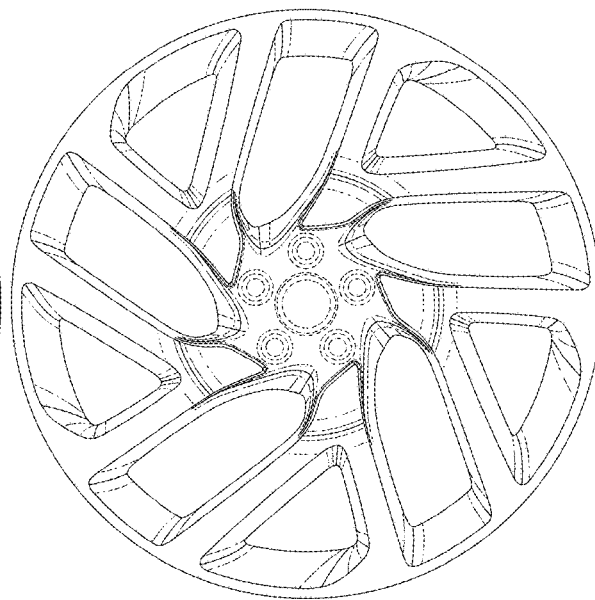
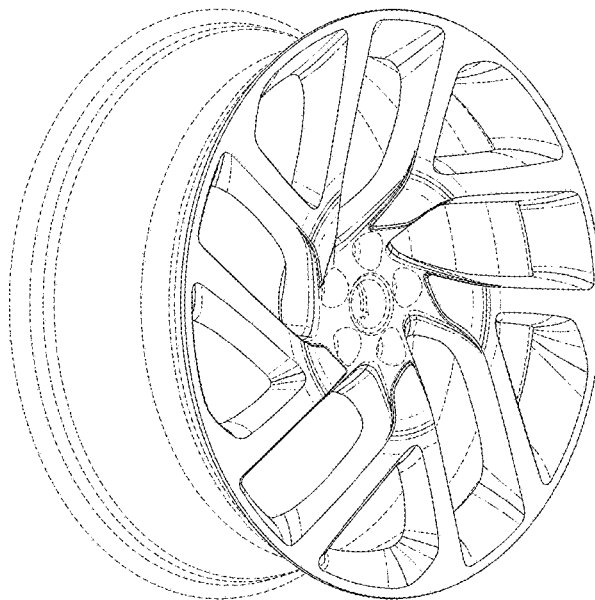

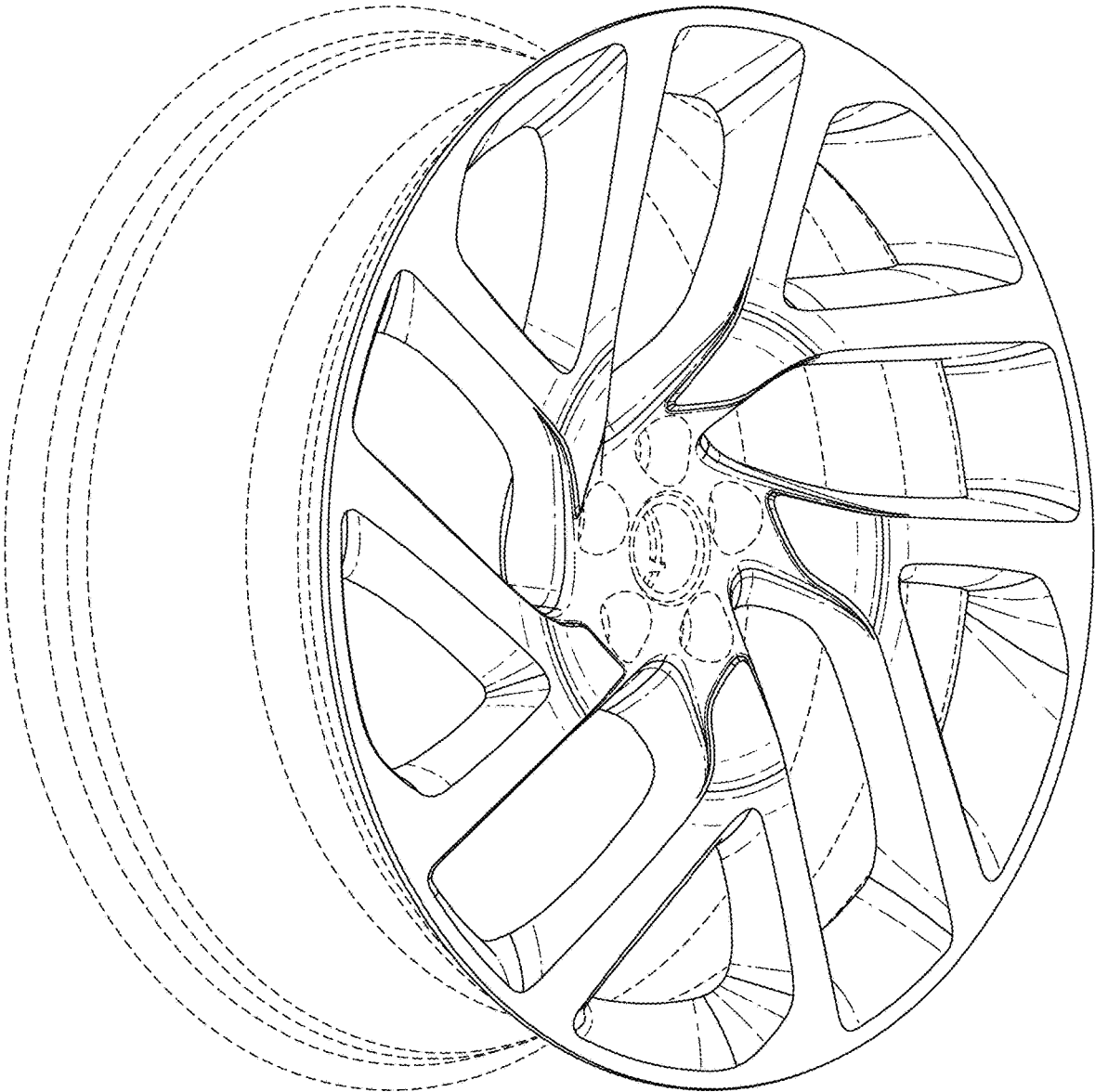

FIG. 1

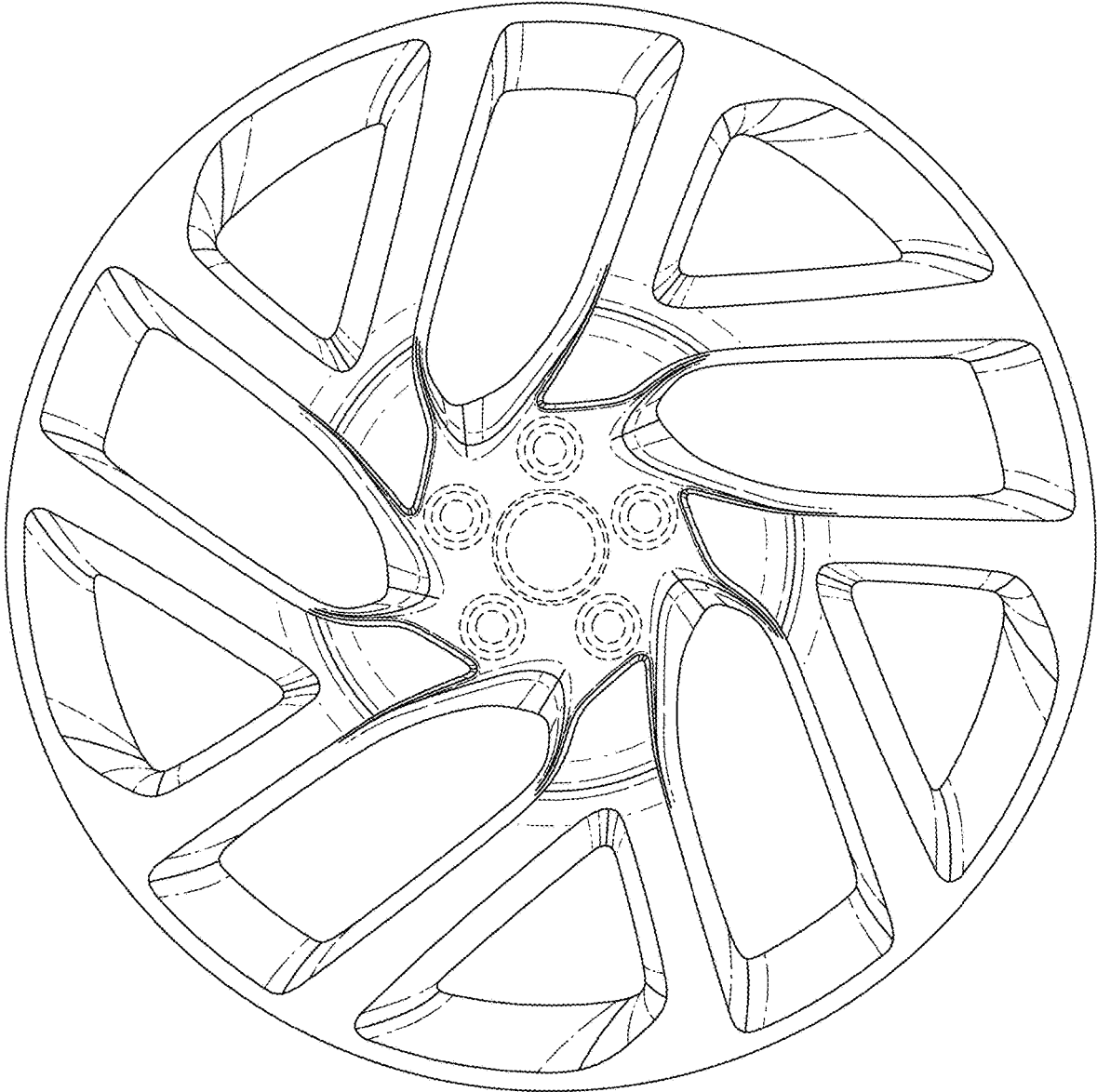

FIG. 2

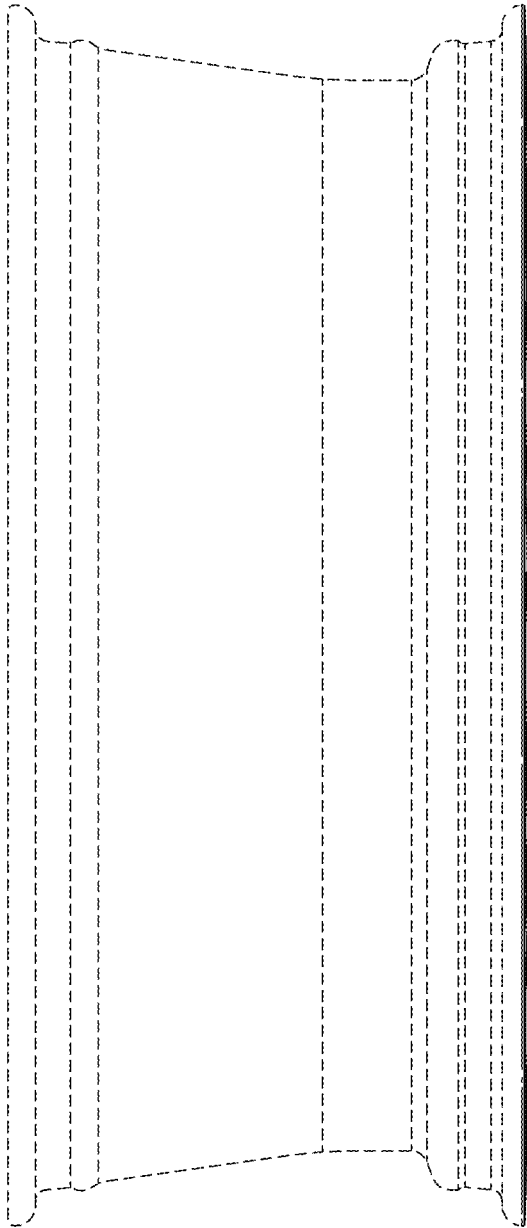

FIG. 3