



- (51) International Patent Classification:  
A61M 5/24 (2006.01) A61B 5/00 (2006.01)  
A61M 5/315 (2006.01)
- (21) International Application Number:  
PCT/EP2013/058322
- (22) International Filing Date:  
22 April 2013 (22.04.2013)
- (25) Filing Language: English
- (26) Publication Language: English
- (71) Applicant: SANOFI-AVENTIS DEUTSCHLAND GMBH [DE/DE]; Brüningstraße 50, 65929 Frankfurt am Main (DE).
- (72) Inventors: BLEI, Gertrud; Unter der Lobdeburg 8, 07747 Jena (DE). BENEDIX, Günther; Drackendorfer Str. 6, 07747 Jena (DE). BOCK, Mario; Am Planetarium 18, 07743 Jena (DE).

- (81) Designated States (unless otherwise indicated, for every kind of national protection available): AE, AG, AL, AM, AO, AT, AU, AZ, BA, BB, BG, BH, BN, BR, BW, BY, BZ, CA, CH, CL, CN, CO, CR, CU, CZ, DE, DK, DM, DO, DZ, EC, EE, EG, ES, FI, GB, GD, GE, GH, GM, GT, HN, HR, HU, ID, IL, IN, IS, JP, KE, KG, KM, KN, KP, KR, KZ, LA, LC, LK, LR, LS, LT, LU, LY, MA, MD, ME, MG, MK, MN, MW, MX, MY, MZ, NA, NG, NI, NO, NZ, OM, PA, PE, PG, PH, PL, PT, QA, RO, RS, RU, RW, SC, SD, SE, SG, SK, SL, SM, ST, SV, SY, TH, TJ, TM, TN, TR, TT, TZ, UA, UG, US, UZ, VC, VN, ZA, ZM, ZW.
- (84) Designated States (unless otherwise indicated, for every kind of regional protection available): ARIPO (BW, GH, GM, KE, LR, LS, MW, MZ, NA, RW, SD, SL, SZ, TZ, UG, ZM, ZW), Eurasian (AM, AZ, BY, KG, KZ, RU, TJ, TM), European (AL, AT, BE, BG, CH, CY, CZ, DE, DK, EE, ES, FI, FR, GB, GR, HR, HU, IE, IS, IT, LT, LU, LV, MC, MK, MT, NL, NO, PL, PT, RO, RS, SE, SI, SK, SM,

[Continued on next page]

(54) Title: SUPPLEMENTAL DEVICE FOR ATTACHMENT TO AN INJECTION DEVICE

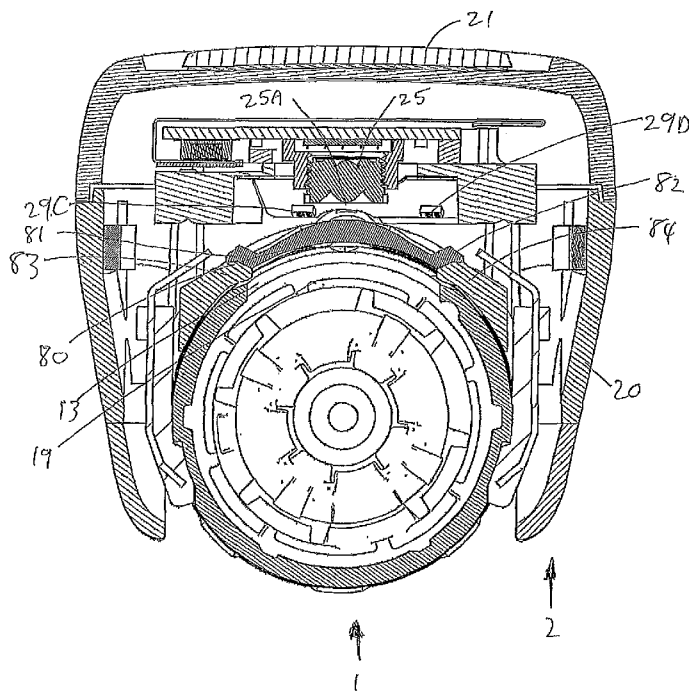

(57) Abstract: A supplemental device for attachment to an injection device including a dosage window (13) covering a sleeve on which dose values are marked is provided. The supplemental device comprises: a main body (20); an arrangement for supporting the main body of the supplemental device in a predetermined positional relationship with the injection device; a transparent protection window (80) located at a surface of the main body that is aligned with the dosage window of the injection pen when in use; and a sensor (25) arrangement supported in the main body and having a sensor directed at the protection window. The protection window has an optical power. The protection window may be a cylindrical lens or a toric lens.

Figure 15

WO 2014/173434 A1

TR), OAPI (BF, BJ, CF, CG, CI, CM, GA, GN, GQ, GW, ML, MR, NE, SN, TD, TG). **Published:**

— *with international search report (Art. 21(3))*

**Declarations under Rule 4.17:**

— *of inventorship (Rule 4.17(iv))*

## Supplemental Device for Attachment to an Injection Device

### Field of the Invention

The present invention relates to a supplemental device for attachment to an injection device.

### Background of the Invention

A variety of diseases exists that require regular treatment by injection of a medicament. Such injection can be performed by using injection devices, which are applied either by medical personnel or by patients themselves. As an example, type-1 and type-2 diabetes can be treated by patients themselves by injection of insulin doses, for example once or several times per day. For instance, a pre-filled disposable insulin pen can be used as an injection device. Alternatively, a re-usable pen may be used. A re-usable pen allows replacement of an empty medicament cartridge by a new one. Either pen may come with a set of one-way needles that are replaced before each use. The insulin dose to be injected can then for instance be manually selected at the insulin pen by turning a dosage knob and observing the actual dose from a dose window or display of the insulin pen. The dose is then injected by inserting the needle into a suited skin portion and pressing an injection button of the insulin pen. To be able to monitor insulin injection, for instance to prevent false handling of the insulin pen or to keep track of the doses already applied, it is desirable to measure information related to a condition and/or use of the injection device, such as for instance information on the injected insulin type and dose.

It has been described, for instance in WO 2011/117212 to provide a supplementary device comprising a mating unit for releasably attaching the device to an injection device. The device includes a camera and is configured to perform optical character recognition (OCR) on captured images visible through a dosage window of the injection pen, thereby to determine a dose of medicament that has been dialled into the injection device.

### Summary of Some Embodiments of the Invention

A first aspect of the invention provides a supplemental device configured for attachment to an injection the supplemental device comprising:

a main body;

an arrangement for supporting the main body of the supplemental device in a predetermined positional relationship with the injection device;

a transparent protection window located at a surface of the main body ;and

a sensor arrangement supported in the main body and having a sensor directed at the protection window,

wherein the protection window is configured as a cylindrical lens or a toric lens with an optical power.

This arrangement can correct for pin cushion distortion provided by the sensor arrangement, the distance between the sensor arrangement and the dosage window and/or the curved shape of a sleeve that is viewable through the protection window. Moreover, this can be achieved through a simple and inexpensive arrangement.

The protection window may be configured as a toric lens, or it may be configured as a cylindrical lens. A cylindrical lens may be easier to produce. Both may have similar ability to correct pin cushion distortion.

A first portion of the protection window may be configured as a cylindrical or toric lens and wherein a second portion of the protection window has a different optical power to the first portion. This can allow part of the protection window that is used in the optical imaging system to have the optical power needed to reduce pin cushion distortion whilst allowing the second portion not to be required to have the optical power. The second portion may be used for illuminating the sleeve visible through the dosage window and/or for mechanical support for the first portion.

The supplemental device may comprise an illumination arrangement comprising one or more sources of light, each of the one or more sources of light being directed at the protection window. This can improve operation of the sensor arrangement. The

protection window can assist in illuminating the sleeve visible through the dosage window.

The supplemental device may comprise an illumination arrangement comprising one or more sources of light, each of the one or more sources of light being directed at the protection window, wherein a first portion of the protection window may be configured as a cylindrical or toric lens, wherein a second portion of the protection window has a different optical power to the first portion. The first portion of the protection window may be in the optical path between the sensor arrangement and the dosage window of the injection pen when the device is in use. The second portion of the protection window may be not in the optical path between the sensor arrangement and the dosage window of the injection pen when the device is in use. The second portion of the protection window may be in the optical path between the illumination arrangement and the dosage window of the injection pen when the device is in use.

The supplemental device may comprise an illumination arrangement comprising two or more sources of light, each of the two or more sources of light being directed at the protection window, wherein the two or more sources of light are located on opposite sides of the sensor arrangement, wherein a central portion of the protection window may be configured as a cylindrical or toric lens, wherein a periphery portion of the protection window has a different optical power to the central portion, wherein the central portion of the protection window may be in the optical path between the sensor arrangement and the dosage window of the injection pen when the device is in use, and wherein the periphery portion of the protection window may be not in the optical path between the sensor arrangement and the dosage window of the injection pen when the device is in use but may be in the optical path between the illumination arrangement and the dosage window of the injection pen when the device is in use.

The transparent protection window may be formed of optical plastic. This can allow the transparent protection window to be provided inexpensively.

The transparent protection window may be provided with an anti-reflective coating on at least one surface thereof. This can improve the optical imaging arrangement and provide more reliable reading of a sleeve visible through the dosage window. The anti-reflective coating may comprise plural dielectric layers. This can remove reflexes effectively in a stable arrangement. The anti-reflective coating may comprise between three and five dielectric layers.

The protection window may be sealed to the main body so as to prevent the ingress of material into the supplemental device around the protection window. This can avoid the need for a separate sealing arrangement.

Another aspect of the invention provides a system comprising a supplemental device as above and an injection device. Here, a surface of the protection window that is furthest from the sensor arrangement may lie on a curved surface of an imaginary cylinder having an axis coincident with a longitudinal axis of the injection device and the surface of the protection window that is furthest from the sensor arrangement may lie in close proximity with a dosage window of the injection device when the supplemental device is installed on the injection device. This can contribute to a compact arrangement for the supplemental device.

A second aspect of the invention provides a supplemental device for attachment to an injection device including a dosage window covering a sleeve on which dose values are marked, the supplemental device comprising:

- a main body;
  - an arrangement for supporting the main body of the supplemental device in a predetermined positional relationship with the injection device;
  - a transparent protection window located at a surface of the main body that is aligned with the dosage window of the injection pen when in use; and
  - a sensor arrangement supported in the main body and having a sensor directed at the protection window,
- wherein the protection window has an optical power.

This arrangement can correct for pin cushion distortion provided by the sensor arrangement, the distance between the sensor arrangement and the dosage window and/or the curved shape of a sleeve that is viewable through the protection window. Moreover, this can be achieved through a simple and inexpensive arrangement.

The protection window may be configured as a toric lens, or it may be configured as a cylindrical lens. A cylindrical lens may be easier to produce. Both may have similar ability to correct pin cushion distortion.

A first portion of the protection window may have the optical power and a second portion of the protection window may have a different optical power to the first portion. This can allow part of the protection window that is used in the optical imaging system to have the optical power needed to reduce pin cushion distortion whilst allowing the second portion not to be required to have the optical power. The second portion may be used for illuminating the sleeve visible through the dosage window and/or for mechanical support for the first portion.

The supplemental device may comprise an illumination arrangement comprising one or more sources of light, each of the one or more sources of light being directed at the protection window. This can improve operation of the sensor arrangement. The protection window can assist in illuminating the sleeve visible through the dosage window.

The supplemental device may comprise an illumination arrangement comprising one or more sources of light, each of the one or more sources of light being directed at the protection window, wherein a first portion of the protection window has the optical power, wherein a second portion of the protection window has a different optical power to the first portion, wherein the first portion of the protection window may be in the optical path between the sensor arrangement and the dosage window of the injection pen when the device is in use, and wherein the second portion of the protection window may be not in the optical path between the sensor arrangement and the dosage window of the injection pen when the device is in use but may be in the optical path between the

illumination arrangement and the dosage window of the injection pen when the device is in use.

The supplemental device may comprise an illumination arrangement comprising two or more sources of light, each of the two or more sources of light being directed at the protection window, wherein the two or more sources of light are located on opposite sides of the sensor arrangement, wherein a central portion of the protection window has the optical power, wherein a periphery portion of the protection window has a different optical power to the central portion, wherein the central portion of the protection window may be in the optical path between the sensor arrangement and the dosage window of the injection pen when the device is in use, and wherein the periphery portion of the protection window may be not in the optical path between the sensor arrangement and the dosage window of the injection pen when the device is in use but may be in the optical path between the illumination arrangement and the dosage window of the injection pen when the device is in use.

The transparent protection window may be formed of optical plastic. This can allow the transparent protection window to be provided inexpensively.

The transparent protection window may be provided with an anti-reflective coating on at least one surface thereof. This can improve the optical imaging arrangement and provide more reliable reading of a sleeve visible through the dosage window. The anti-reflective coating may comprise plural dielectric layers. This can remove reflexes effectively in a stable arrangement. The anti-reflective coating may comprise between three and five dielectric layers.

The protection window may be sealed to the main body so as to prevent the ingress of material into the supplemental device around the protection window. This can avoid the need for a separate sealing arrangement.

Another aspect of the invention provides a system comprising the supplemental device and an injection device. Here, a surface of the protection window that is furthest from



the sensor arrangement may lie on a curved surface of an imaginary cylinder having an axis coincident with a longitudinal axis of the injection device and the surface of the protection window that is furthest from the sensor arrangement may lie in close proximity with a dosage window of the injection device when the supplemental device is installed on the injection device. This can contribute to a compact arrangement for the supplemental device.

Embodiments of the invention will now be described, by way of example only, with reference to the accompanying drawings.

#### Brief Description of the Figures

The figures show:

Fig. 1 is an exploded view of an injection device;

Fig. 1b shows a perspective view of some detail of the injection device of Fig. 1;

Fig. 2a: a schematic illustration of a supplementary device to be releasably attached to the injection device of Fig. 1 according to an embodiment of the present invention;

Fig. 2b: a perspective view of a supplementary device to be releasably attached to the injection device of Fig. 1 according to various embodiments of the present invention;

Fig. 2c: a perspective view of a supplementary device to be releasably attached to the injection device of Fig. 1 according to other embodiments of the present invention;

Figs. 3A and 3b: possible distributions of functions among devices when using a supplementary device (such as the supplementary devices of Fig. 2a and 2b) together with an injection device;

Fig. 4: a schematic view of the supplementary device of Fig. 2a in a state where it is attached to the injection device of Fig. 1 ;

Fig. 5a: a flowchart of a method used in various embodiments;

Fig. 5b: a flowchart of a further method used in various embodiments;

Fig. 5c: a flowchart of a still further method used in various embodiments;

Fig. 6: a schematic illustration of a tangible storage medium 60 according to an embodiment of the present invention; and

Fig. 7: an information sequence chart that illustrates an information flow between various devices according to embodiments of the invention;

Fig. 8 is a side view of the supplemental device of Fig. 2b attached to the injection pen of Fig. 1;

Fig. 9 is a side view of the supplemental device in the same view as Fig. 8 although with the injection pen omitted and with a closure open;

Fig. 10 is a cross-section view through the arrangement of the supplemental device and the injection pen of Fig. 8 prior to engagement of the supplemental device on the injection device;

Fig. 11a is a partial cutaway perspective view of a detail from Fig. 10;

Fig. 11b is a partial cutaway perspective view of another detail from Fig. 10;

Fig. 12 is a cross-sectional view which is the same as Fig. 10 although with the supplemental device mated to the injection device;

Fig. 13 is a cross-sectional view through the supplemental device of Fig. 2b at a location further along the device from the cross-section shown in Fig. 10; and

Fig. 14 is the same cross-section as shown in Fig. 13 although with the supplemental device installed on an injection pen and clamped in place;

Fig. 15: a cross-sectional view through the supplemental device when installed on an injection pen, the cross-section being through a camera and optical system;

Fig. 16a: a left end view of a protective window of the optical system;

Fig. 16b: a plan view of the protective window;

Fig. 16c: a right end view of the protective window;

Fig. 16d: a section A-A of Fig. 16b;

Fig. 16e: a side view of the protective window;

Fig. 16f: a section B-B of Fig. 16b;

Fig. 17: a plan view indicating a location of the camera with respect to the injection pen when the supplemental device is installed;

Fig. 18: a view similar to Fig. 16 and including the protection window; and

Figs. 19a and 19b are drawings showing respectively distortion with and without the protection window in place.

#### Detailed Description of Some Embodiments of the Invention

In the following, embodiments of the present invention will be described with reference to an insulin injection device. The present invention is however not limited to such

application and may equally well be deployed with injection devices that eject other medicaments, or with other types of medical devices.

Fig. 1 is an exploded view of an injection device 1, which may for instance represent Sanofi's Solostar (R) insulin injection pen.

The injection device 1 of Fig. 1 is a pre-filled, disposable injection pen that comprises a housing 10 and contains an insulin container 14, to which a needle 15 can be affixed. The needle is protected by an inner needle cap 16 and an outer needle cap 17, which in turn can be covered by a cap 18. An insulin dose to be ejected from injection device 1 can be selected by turning the dosage knob 12, and the selected dose is then displayed via dosage window 13, for instance in multiples of so-called International Units (IU), wherein one IU is the biological equivalent of about 45.5 micrograms of pure crystalline insulin (1/22 mg). An example of a selected dose displayed in dosage window 13 may for instance be 30 IUs, as shown in Fig. 1. It should be noted that the selected dose may equally well be displayed differently. A label (not shown) is provided on the housing 10. The label includes information about the medicament included within the injection device, including information identifying the medicament. The information identifying the medicament may be in the form of text. The information identifying the medicament may also be in the form of a colour. The information identifying the medicament may also be encoded into a barcode, QR code or the like. The information identifying the medicament may also be in the form of a black and white pattern, a colour pattern or shading.

Turning the dosage knob 12 causes a mechanical click sound to provide acoustical feedback to a user. The numbers displayed in dosage window 13 are printed on a sleeve that is contained in housing 10 and mechanically interacts with a piston in insulin container 14. When needle 15 is stuck into a skin portion of a patient, and then injection button 11 is pushed, the insulin dose displayed in display window 13 will be ejected from injection device 1. When the needle 15 of injection device 1 remains for a certain time in the skin portion after the injection button 11 is pushed, a high percentage of the dose is actually injected into the patient's body. Ejection of the insulin dose also

causes a mechanical click sound, which is however different from the sounds produced when using dosage knob 12.

Injection device 1 may be used for several injection processes until either insulin container 14 is empty or the expiration date of injection device 1 (e.g. 28 days after the first use) is reached.

Furthermore, before using injection device 1 for the first time, it may be necessary to perform a so-called "prime shot" to remove air from insulin container 14 and needle 15, for instance by selecting two units of insulin and pressing injection button 11 while holding injection device 1 with the needle 15 upwards.

For simplicity of presentation, in the following, it will be exemplarily assumed that the ejected doses substantially correspond to the injected doses, so that, for instance when making a proposal for a dose to be injected next, this dose equals the dose that has to be ejected by the injection device. Nevertheless, differences (e.g. losses) between the ejected doses and the injected doses may of course be taken into account.

Fig. 1b is a close-up of the end of the injection device 1. This Fig. shows a locating rib 70 that is located between the viewing window 13 and the dosage knob 12.

Fig. 2a is a schematic illustration of an embodiment of a supplementary device 2 to be releasably attached to injection device 1 of Fig. 1. Supplementary device 2 comprises a housing 20 with a mating unit configured and embrace the housing 10 of injection device 1 of Fig. 1, so that supplementary device 2 sits tightly on housing 10 of injection device 1, but is nevertheless removable from injection device 1, for instance when injection device 1 is empty and has to be replaced. Fig. 2a is highly schematic, and details of the physical arrangement are described below with reference to Figure 2b.

Supplementary device 2 contains optical and acoustical sensors for gathering information from injection device 1. At least a part of this information, for instance a selected dose (and optionally a unit of this dose), is displayed via display unit 21 of

supplementary device 2. The dosage window 13 of injection device 1 is obstructed by supplementary device 2 when attached to injection device 1.

Supplementary device 2 further comprises three user input transducers, illustrated schematically as a button 22. These input transducers 22 allow a user to turn on/off supplementary device 2, to trigger actions (for instance to cause establishment of a connection to or a pairing with another device, and/or to trigger transmission of information from supplementary device 2 to another device), or to confirm something.

Fig. 2b is a schematic illustration of a second embodiment of a supplementary device 2 to be releasably attached to injection device 1 of Fig. 1. Supplementary device 2 comprises a housing 20 with a mating unit configured and embrace the housing 10 of injection device 1 of Fig. 1, so that supplementary device 2 sits tightly on housing 10 of injection device 1, but is nevertheless removable from injection device 1.

Information is displayed via display unit 21 of supplementary device 2. The dosage window 13 of injection device 1 is obstructed by supplementary device 2 when attached to injection device 1.

Supplementary device 2 further comprises three user input buttons or switches. A first button 22 is a power on/off button, via which the supplementary device 2 may for instance be turned on and off. A second button 33 is a communications button. A third button 34 is a confirm or OK button. The buttons 22, 33, 34 may be any suitable form of mechanical switch. These input buttons 22, 33, 34 allow a user to turn on/off supplementary device 2, to trigger actions (for instance to cause establishment of a connection to or a pairing with another device, and/or to trigger transmission of information from supplementary device 2 to another device), or to confirm something.

Fig. 2c is a schematic illustration of a third embodiment of a supplementary device 2 to be releasably attached to injection device 1 of Fig. 1. Supplementary device 2 comprises a housing 20 with a mating unit configured and embrace the housing 10 of

injection device 1 of Fig. 1, so that supplementary device 2 sits tightly on housing 10 of injection device 1, but is nevertheless removable from injection device 1.

Information is displayed via display unit 21 of the supplementary device 2. The dosage window 13 of injection device 1 is obstructed by supplementary device 2 when attached to injection device 1.

Supplementary device 2 further comprises a touch-sensitive input transducer 35. It also comprises a single user input button or switch 22. The button 22 is a power on/off button, via which the supplementary device 2 may for instance be turned on and off. The touch sensitive input transducer 35 can be used to trigger actions (for instance to cause establishment of a connection to or a pairing with another device, and/or to trigger transmission of information from supplementary device 2 to another device), or to confirm something.

Figs. 3A and 3b show possible distributions of functions among devices when using a supplementary device (such as the supplementary devices of Fig. 2a and 2b) together with an injection device.

In constellation 4 of Fig. 3a, the supplementary device 41 (such as the supplementary devices of Fig. 2a and 2b) determines information from injection device 40, and provides this information (e.g. type and/or dose of the medicament to be injected) to a blood glucose monitoring system 42 (e.g. via a wired or wireless connection).

Blood glucose monitoring system 42 (which may for instance be embodied as desktop computer, personal digital assistant, mobile phone, tablet computer, notebook, netbook or ultrabook) keeps a record of the injections a patient has received so far (based on the ejected doses, for instance by assuming that the ejected doses and the injected doses are the same, or by determining the injected doses based on the ejected doses, for instance by assuming that a pre-defined percentage of the ejected dose is not completely received by the patient). Blood glucose monitoring system 42 may for instance propose a type and/or dose of insulin for the next injection for this patient. This

proposal may be based on information on one or more past injections received by the patient, and on a current blood glucose level, that is measured by blood glucose meter 43 and provided (e.g. via a wired or wireless connection) to blood glucose monitoring system 42. Therein, blood glucose meter 43 may be embodied as a separate device that is configured to receive a small blood probe (for instance on a carrier material) of a patient and to determine the blood glucose level of the patient based on this blood probe. Blood glucose meter 43 may however also be a device that is at least temporarily implanted into the patient, for instance in the patient's eye or beneath the skin.

Fig. 3b is a modified constellation 4' where the blood glucose meter 43 of Fig. 3a has been included into blood glucose monitoring system 42 of Fig. 3a, thus yielding the modified blood glucose monitoring system 42' of Fig. 3b. The functionalities of injection device 40 and supplementary device 41 of Fig. 3a are not affected by this modification. Also the functionality of blood glucose monitoring system 42 and blood glucose meter 43 combined into blood glucose monitoring system 42' are basically unchanged, apart from the fact that both are now comprised in the same device, so that external wired or wireless communication between these devices is no longer necessary. However, communication between blood glucose monitoring system 42 and blood glucose meter 43 takes place within system 42'.

Fig. 4 shows a schematic view of the supplementary device 2 of Fig. 2a in a state where it is attached to injection device 1 of Fig. 1.

With the housing 20 of supplementary device 2, a plurality of components are comprised. These are controlled by a processor 24, which may for instance be a microprocessor, a Digital Signal Processor (DSP), Application Specific Integrated Circuit (ASIC), Field Programmable Gate Array (FPGA) or the like. Processor 24 executes program code (e.g. software or firmware) stored in a program memory 240, and uses a main memory 241, for instance to store intermediate results. Main memory 241 may also be used to store a logbook on performed ejections/injections. Program

memory 240 may for instance be a Read-Only Memory (ROM), and main memory may for instance be a Random Access Memory (RAM).

In embodiments such as those shown in Fig. 2b, processor 24 interacts with a first button 22, via which supplementary device 2 may for instance be turned on and off. A second button 33 is a communications button. The second button may be used to trigger establishment of a connection to another device, or to trigger a transmission of information to another device. A third button 34 is a confirm or OK button. The third button 34 can be used to acknowledge information presented to a user of supplementary device 2. In embodiments such as those shown in Fig. 2c, two of the buttons 33, 34 may be omitted. Instead, one or more capacitive sensors or other touch sensors are provided.

Processor 24 controls a display unit 21, which is presently embodied as a Liquid Crystal Display (LCD). Display unit 21 is used to display information to a user of supplementary device 2, for instance on present settings of injection device 1, or on a next injection to be given. Display unit 21 may also be embodied as a touch-screen display, for instance to receive user input.

Processor 24 also controls an optical sensor 25, embodied as an Optical Character Recognition (OCR) reader, that is capable of capturing images of the dosage window 13, in which a currently selected dose is displayed (by way of numbers printed on the sleeve 19 contained in injection device 1, which numbers are visible through the dosage window 13). OCR reader 25 is further capable of recognizing characters (e.g. numbers) from the captured image and to provide this information to processor 24. Alternatively, unit 25 in supplementary device 2 may only be an optical sensor, e.g. a camera, for capturing images and providing information on the captured images to processor 24. Then processor 24 is responsible for performing OCR on the captured images.

Processor 24 also controls light-sources such as light emitting diodes (LEDs) 29 to illuminate the dosage window 13, in which a currently selected dose is displayed. A diffuser may be used in front of the light-sources, for instance a diffuser made from a



piece of acrylic glass. Furthermore, the optical sensor may comprise a lens system, for instance including two aspheric lenses. The magnification ratio (image size to object size ratio) may be smaller than 1. The magnification ratio may be in the range of 0.05 to 0.5. In one embodiment the magnification ratio may be 0.15.

Processor 24 further controls a photometer 26, that is configured to determine an optical property of the housing 10 of injection device 1, for example a colour or a shading. The optical property may only be present in a specific portion of housing 10, for example a colour or colour coding of sleeve 19 or of an insulin container comprised within injection device 1, which colour or colour coding may for instance be visible through a further window in housing 10 (and/or in sleeve 19). Information on this colour is then provided to processor 24, which may then determine the type of injection device 1 or the type of insulin contained in injection device 1 (e.g. SoloStar Lantus with purple colour and SoloStar Apidra with blue colour). Alternatively, a camera unit may be used instead of photometer 26, and an image of the housing, sleeve or insulin container may then be provided to processor 24 to determine the colour of the housing, sleeve or insulin container by way of image processing. Further, one or more light sources may be provided to improve reading of photometer 26. The light source may provide light of a certain wavelength or spectrum to improve colour detection by photometer 26. The light source may be arranged in such a way that unwanted reflections, for example by dosage window 13, are avoided or reduced. In an example embodiment, instead of or in addition to photometer 26, a camera unit may be deployed to detect a code (for instance a bar code, which may for instance be a one- or two-dimensional bar code) related to the injection device and/or the medicament contained therein. This code may for instance be located on the housing 10 or on a medicament container contained in injection device 1, to name but a few examples. This code may for instance indicate a type of the injection device and/or the medicament, and/or further properties (for instance a expiration date).

Processor 24 further controls (and/or receives signals from) an acoustic sensor 27, which is configured to sense sounds produced by injection device 1. Such sounds may for instance occur when a dose is dialled by turning dosage knob 12 and/or when a

dose is ejected/injected by pressing injection button 11, and/or when a prime shot is performed. These actions are mechanically similar but nevertheless sound differently (this may also be the case for electronic sounds that indicate these actions). Either the acoustic sensor 27 and/or processor 24 may be configured to differentiate these different sounds, for instance to be able to safely recognize that an injection has taken place (rather than a prime shot only).

Processor 24 further controls an acoustical signal generator 23, which is configured to produce acoustical signals that may for instance be related to the operating status of injection device 1, for instance as feedback to the user. For example, an acoustical signal may be launched by acoustical signal generator 23 as a reminder for the next dose to be injected or as a warning signal, for instance in case of misuse. Acoustical signal generator may for instance be embodied as a buzzer or loudspeaker. In addition to or as an alternative to acoustical signal generator 23, also a haptic signal generator (not shown) may be used to provide haptic feedback, for instance by way of vibration.

Processor 24 controls a wireless unit 28, which is configured to transmit and/or receive information to/from another device in a wireless fashion. Such transmission may for instance be based on radio transmission or optical transmission. In some embodiments, the wireless unit 28 is a Bluetooth transceiver. Alternatively, wireless unit 28 may be substituted or complemented by a wired unit configured to transmit and/or receive information to/from another device in a wire-bound fashion, for instance via a cable or fibre connection. When data is transmitted, the units of the data (values) transferred may be explicitly or implicitly defined. For instance, in case of an insulin dose, always International Units (IU) may be used, or otherwise, the used unit may be transferred explicitly, for instance in coded form.

Processor 24 receives an input from a pen detection switch 30, which is operable to detect whether the pen 1 is present, i.e. to detect whether the supplementary device 2 is coupled to the injection device 1.

A battery 32 powers the processor 24 and other components by way of a power supply 31.

The supplementary device 2 of Fig. 4 is thus capable of determining information related to a condition and/or use of injection device 1. This information is displayed on the display 21 for use by the user of the device. The information may be either processed by supplementary device 2 itself, or may at least partially be provided to another device (e.g. a blood glucose monitoring system).

Figs. 5a-5c are flowcharts of embodiments of methods according to the present invention. These methods may for instance be performed by processor 24 of supplementary device 2 (see Figs. 2b and 4), but also by a processor of supplementary device 3 of Fig. 2b, and may for instance be stored in program memory 240 of supplementary device 2, which may for instance take the shape of tangible storage medium 60 of Fig. 6.

Fig. 5a shows method steps that are performed in scenarios as shown in Figs. 3a and 3b, where information read by supplementary device 41 from injection device 40 is provided to blood glucose monitoring system 42 or 42' without receiving information back from blood glucose monitoring system 42 or 42'.

The flowchart 500 starts for instance when the supplementary device is turned on or is otherwise activated. In a step 501, a type of medicament, for example insulin, provided by the injection device is determined, for instance based on colour recognition or based on recognition of a code printed on injection device or a component thereof as already described above. Detection of the type of medicament may not be necessary if a patient always takes the same type of medicament and only uses an injection device with this single type of medicament. Furthermore, determination of the type of medicament may be ensured otherwise (e.g. by the key-recess pair shown in Fig. 4 that the supplementary device is only useable with one specific injection device, which may then only provide this single type of medicament).

In a step 502, a currently selected dose is determined, for instance by OCR of information shown on a dosage window of injection device as described above. This information is then displayed to a user of the injection device in a step 503.

In a step 504, it is checked if an ejection has taken place, for instance by sound recognition as described above. Therein, a prime shot may be differentiated from an actual injection (into a creature) either based on respectively different sounds produced by the injection device and/or based on the ejected dose (e.g. a small dose, for instance less than a pre-defined amount of units, e.g. 4 or 3 units, may be considered to belong to a prime shot, whereas larger doses are considered to belong to an actual injection).

If an ejection has taken place, the determined data, i.e. the selected dose and - if applicable - the type of medicament (e.g. insulin), is stored in the main memory 241, from where it may later be transmitted to another device, for instance a blood glucose monitoring system. If a differentiation has been made concerning the nature of the ejection, for instance if the ejection was performed as a prime shot or as an actual injection, this information may also be stored in the main memory 241, and possibly later transmitted. In the case of an injection having been performed, at step 505 the dose is displayed on the display 21. Also displayed is a time since the last injection which, immediately after injection, is 0 or 1 minute. The time since last dose may be displayed intermittently. For instance, it may be displayed alternately with the name or other identification of the medicament that was injected, e.g. Apidra or Lantus.

If ejection was not performed at step 504, steps 502 and 503 are repeated.

After display of the delivered dose and time data, the flowchart 500 terminates.

Fig. 5b shows in more detail exemplary method steps that are performed when the selected dose is determined based on the use of optical sensors only. For instance, these steps may be performed in step 502 of Fig. 5a.

In a step 901, a sub-image is captured by an optical sensor such as optical sensor 25 of supplementary device 2. The captured sub-image is for instance an image of at least a part of the dosage window 13 of injection device 1, in which a currently selected dose is displayed (e.g. by way of numbers and/or a scale printed on the sleeve 19 of injection device 1, which is visible through the dosage window 13). For instance, the captured sub-image may have a low resolution and/or only show a part of the part of sleeve 19 which is visible through dosage window 13. For instance, the captured sub-image either shows the numbers or the scale printed on the part of sleeve 19 of injection device 1 which is visible through dosage window 13. After capturing an image, it is, for instance, further processed as follows:

- Division by a previously captured background image;
- Binning of the image(s) to reduce the number of pixels for further evaluations;
- Normalization of the image(s) to reduce intensity variations in the illumination;
- Sheering of the image(s); and/or
- Binarization of the image(s) by comparing to a fixed threshold.

Several or all of these steps may be omitted if applicable, for instance if a sufficiently large optical sensor (e.g. a sensor with sufficiently large pixels) is used.

In a step 902, it is determined whether or not there is a change in the captured sub-image. For instance, the currently captured sub-image may be compared to the previously captured sub-image(s) in order to determine whether or not there is a change. Therein, the comparison to previously captured sub-images may be limited to the sub-image of the previously captured sub-images that was captured immediately before the current sub-image was captured and/or to the sub-images of the previously captured sub-images that were captured within a specified period of time (e.g. 0.1 seconds) before the current sub-image was captured. The comparison may be based on image analysis techniques such as pattern recognition performed on the currently captured sub-image and on the previously captured sub-image. For instance, it may be analyzed whether the pattern of the scale and/or the numbers visible through the dosage window 13 and shown in the currently captured sub-image and in the previously

captured sub-image is changed. For instance, it may be searched for patterns in the image that have a certain size and/or aspect ratio and these patterns may be compared with previously saved patterns. Steps 901 and 902 may correspond to a detection of a change in the captured image.

If it is determined in step 902 that there is a change in the sub-image, step 901 is repeated. Otherwise in a step 903, an image is captured by an optical sensor such as optical sensor 25 of supplementary device 2. The captured image is for instance an image of the dosage window 13 of injection device 1, in which a currently selected dose is displayed (e.g. by way of numbers and/or a scale printed on the sleeve 19 of injection device 1, which is visible through the dosage window 13). For instance, the captured image may have a resolution being higher than the resolution of the captured sub-image. The captured image at least shows the numbers printed on the sleeve 19 of injection device 1 which are visible through the dosage window 13.

In a step 904, optical character recognition (OCR) is performed on the image captured in step 903 in order to recognize the numbers printed on the sleeve 19 of injection device 1 and visible through the dosage window 13, because these numbers correspond to the (currently) selected dose. In accord to the recognized numbers, the selected dose is determined, for instance by setting a value representing the selected dose to the recognized numbers.

In a step 905, it is determined whether or not there is a change in the determined selected dose and, optionally, whether or not the determined selected dose does not equal zero. For instance, the currently determined selected dose may be compared to the previously determined selected dose(s) in order to determine whether or not there is a change. Therein, the comparison to previously determined selected dose(s) may be limited to the previously determined selected dose(s) that were determined within a specified period of time (e.g. 3 seconds) before the current selected dose was determined. If there is no change in the determined selected dose and, optionally, the determined selected dose does not equal zero, the currently determined selected dose is returned/forwarded for further processing (e.g. to processor 24).

Thus, the selected dose is determined if the last turn of the dosage knob 12 is more than 3 seconds ago. If the dosage knob 12 is turned within or after these 3 seconds and the new position remains unchanged for more than 3 seconds, this value is taken as the determined selected dose.

Fig. 5c shows in more detail method steps that are performed when the selected dose is determined based on the use of acoustical and optical sensors. For instance, these steps may be performed in step 502 of Figs. 5a.

In a step 1001, a sound is captured by an acoustical sensor such as acoustical sensor 27 of supplementary device 2.

In a step 1002, it is determined whether or not the captured sound is a click sound. The captured sound may for instance be a click sound that occurs when a dose is dialled by turning dosage knob 12 of injection device 1 and/or when a dose is ejected/injected by pressing injection button 11, and/or when a prime shot is performed. If the captured sound is not a click sound, step 1001 is repeated. Otherwise in a step 1003, an image is captured by an optical sensor such as optical sensor 25 of supplementary device 2. Step 1003 corresponds to step 903 of flowchart 900.

In a step 1004, an OCR is performed on the image captured in step 1003. Step 1004 corresponds to step 904 of flowchart 900.

In a step 1005, it is determined whether or not there is a change in the determined selected dose and, optionally, whether or not the determined selected dose does not equal zero. Step 1005 corresponds to step 905 of flowchart 900.

There might be a slight advantage of the acoustic approach shown in Fig. 5c when it comes to power consumption of the supplementary device, because permanently capturing images or sub-images as shown in Fig. 5b typically is more power consuming than listening to an acoustical sensor such as a microphone.

Fig. 6 is a schematic illustration of a tangible storage medium 600 (a computer program product) that comprises a computer program 601 with program code 602. This program code may for instance be executed by processors contained in the supplementary device, for instance processor 24 of supplementary device 2 of Figs. 2 and 4. For instance, storage medium 600 may represent program memory 240 of supplementary device 2 of Fig. 4. Storage medium 600 may be a fixed memory, or a removable memory, such as for instance a memory stick or card.

As described in detail above, embodiments of the present invention allow connection of a standard injection device, in particular an insulin device, with a blood glucose monitoring system in a useful and productive way.

Embodiments of the present invention introduce a supplementary device to allow for this connection, assuming the blood glucose monitoring system has wireless or other communication capabilities. The benefits of providing such a supplementary device have been described, for instance in WO 2011/117212.

The term “drug” or “medicament”, as used herein, means a pharmaceutical formulation containing at least one pharmaceutically active compound, for instance as described in WO 2011/117212.

.The mechanical arrangement of the supplemental device 2 and the manner in which it is attached to the injection device 1 will now be described with reference to Figures 8 to 14.

As is best seen from Figure 8, the supplemental device 2 is attached to the injection pen 1 close to the dosage knob 12 with the display 21 uppermost in the orientation shown (which is the same for all of Figs. 8 to 14). The plane of the display 21 lies generally transverse to the longitudinal axis of the injection device 1, and is perpendicular to the page of Figures 8, 9, 10, 12, 13 and 14.



A closure 68 extends from a shaft 59 of a hinge, the closure extending underneath the injection pen. The closure 68 is connected to the supplemental device 2 on the right side (looking at the injection device 1 with the injection button closest to the viewer), extends underneath the injection pen 1 and connects with the supplemental device on the left side thereof.

The supplemental device 2 of these illustrated embodiments includes two features that contribute to correct alignment of the supplemental device 2 on the injection device 1, and one feature that results in securing of the supplemental device 2 to the injection device 1. The features that contribute to correct alignment of the supplemental device 2 on the injection device 1 can be termed alignment arrangements. The features that contribute to securing of the supplemental device 2 to the injection device 1 can be termed a securing arrangement.

The correct alignment of the supplemental device 2 on the injection device 1, ensures that the OCR reader 25 is correctly aligned with the dosage window 13. Correct alignment allows correct operation and reliable readings. Ensuring that there can be correct alignment between the supplemental device 2 and the injection device 1 in use allows a simpler design for the OCR reader 25, in particular because it does not need to be designed to be able to accommodate different alignments between the devices 1, 2.

The first alignment feature is a locating channel 71. The locating channel 71 is located at the uppermost part of an injection device receiving channel 58 that is defined between the main body of the supplemental part and the closure 68 when in the closed position.

The locating channel 71 is best shown in Figures 11a and 11b. From here, it will be seen that the locating channel is formed at the end of the supplemental device that is closest to the dosage knob 12 when the supplemental device 2 is fitted to the injection device 1.

As is best seen in Figure 1b, the locating rib 70 is located between the display window 13 and the dosage knob 12. In this example, the locating rib 70 extends for the whole of the distance between the display window 13 and the dosage knob 12. In other examples, the locating rib is shorter. The locating rib 70 is taller at the end that is adjacent the dosage knob 12 and tapers down to a zero height at the junction with the display window 13. As can be seen from Figure 1b, the taper of the uppermost edge of the locating rib 70 is slightly curved. The gradient of the taper is less at the part of the locating rib 70 that is closest to the dosage knob 12 and is greater along the locating rib to the location of the display window 13. The shape of the locating rib 70 is such that the gradient continually increases as one moves from the position of the locating rib 70 that is adjacent to the dosage knob 12 to the position of the locating rib 70 that is adjacent the display window 13.

The thickness of the locating rib 70, the thickness being the dimension that is circumferential to the main body of the injection device 1, varies along the length of the locating rib 70. The thickness of the locating rib 70 is greatest at the end adjacent the dosage knob 12 and is least at the end adjacent the display window 13. The thickness of the locating rib 70 gradually decreases as one moves from the end of the locating rib adjacent the dosage knob 12 to the end of the locating rib that is adjacent the display window 13.

The cross-section of the locating rib, the cross-section being a section taken perpendicular to the longitudinal axis of the injection pen 1, is of a rounded triangle. The cross-section of the locating rib 70 is approximately the same for its entire length, although of course the size varies.

The locating channel 71 is dimensioned so as to correspond closely to the shape and size of the locating rib 70 that is present on the injection pen 1.

The locating channel 71 has a size and shape that corresponds closely to the size and shape of the locating rib 70. The locating channel 71 is slightly larger than the locating rib so as to ensure that the locating rib can be located within the locating channel 71.

When the locating rib 70 is within the locating channel 71, the corresponding sizes ensure that the two features mate together. This assists in ensuring correct positioning of the supplemental device 2 on the injection device 1.

Other features of the supplemental device 2 and the injection pen 1 that assist in ensuring correct alignment between the two devices will now be described. As best seen in Figure 1b, the injection pen 1 is provided with indents on either side of its body at locations close to the dosage knob 12. In Figure 1b, a left side indent 52 is shown. A right indent 51, which is shown in Figures 10 and 12, is located in a corresponding position on the right side of the injection pen 1.

The left and right indents 51, 52 are relatively shallow depressions. The indents 51, 52 have sloping sides, that is the sides of the indents 51, 52 are not parallel. Also, they are not radial with respect to the longitudinal axis of the injection pen 1. In these embodiments, the slope of the sides of the left and right indents 51, 52 is different for different parts of the indents. In particular, the gradient of the slope of the sides of the indents is less at the part of the indents that is furthest from the display window 13 and is greatest at the part of the indents 51, 52 that is closest to the display window 13. In these examples, the slope of the indents changes between these two extremes, for instance in a linear fashion.

The slope of the sides of the indent may for instance be between 30 and 70 degrees at the part that is furthest from the display window 13. The slope may for instance be between 60 and 80 degrees for the part that is closest to the display window 13. The greater angle of slope at the part closer to the display window 13 aids engagement of a face of a protuberance within the indent 51, 52 in such a way as to provide some resistance against removal of the supplemental device 2 in a direction radial to the longitudinal axis of the injection device 1.

As is best seen in Figures 10 and 11, the left and right protuberances 53, 54 are shaped to correspond to the shapes of the right and left indents 51, 52 respectively. In this way, the right and left protuberances 53, 54 fit within the right and left indents 51, 52

respectively when the supplementary device 2 is correctly positioned on the injection pen 1. The external dimensions of the right and left protuberances 53, 54 are slightly smaller than the internal dimensions of the right and left indents 51, 52 so as to ensure that the protuberances fit within their respective indent.

In these embodiments, the left and right protuberance 52 is shaped to correspond closely to the shape of the right indent 51. In this way, the right protuberances 53 fits snugly within the right indent 51 when the supplementary device 2 is correctly positioned on the injection pen 1. The left protuberance 54 is shaped similarly to the right protuberance 53, although it is less tall. Put another way, it is like the right protuberance 53 but with the top part missing or cut off. This is the reason for the end face of the left protuberance 54 having a larger area than the right protuberance 53. The different sizes for the protuberances 53, 54 helps the protuberances find engagement within the indents 51, 52. The right protuberance 53 can be consider to be a master to the left protuberance, which is a slave.

The right protuberance 53 is located at the end of the right arm 55, which is best shown in Figure 11b.

As can be seen from Figure 11a, the left protuberance 54 is located at the end of the left arm 56.

As can be best seen from Figure 10, the right and left arms 55, 56 depend substantially vertically from the body 20 of the supplementary device 2. The right and left arms 55, 56 are thus formed either side of the injection device receiving channel 58.

A biasing feature 67, in the form of a u-shaped spring, is coupled to each of the right and left arms 55, 56. The effect of the spring 67 is to bias the right and left arms into a certain position. The position into which the right and left arms 55, 56 are biased is such that the distance between the innermost surfaces of the right and left protuberances 53, 54 is slightly less than the distance between the bottoms of the right

and left indents 51, 52. The effect of the spring 67 is to resist movement of the protuberances 53, 54 and the arms 55, 56, away from one another.

Because the slopes of the sides of the protuberances 53, 54 match the sides of the indents 51, 52, the sloped sides of the protuberances 53, 54 at the distal ends of the arms 55, 56 is relatively shallow. This assists in sliding the protuberances 53, 54 over the external surface of the body 10 of the injection pen 1 as the supplemental device is being fitted. This is best demonstrated with reference to Figures 10 and 12.

As is shown in Figure 10, the supplemental device 2 is located with respect to the injection pen 1 such that the ends of the right and left arms 55, 56, in particular the protuberances 53, 54, are just touching the housing 10 of the injection pen 1. The protuberances 53, 54 here contact the housing to the left and right sides of the display window 13.

The left and right arms 55, 56 are present behind flaps 60 that depend from the supplemental device 2 on both the left and right sides. As can be seen from Figure 10, the flaps, or protecting walls 60, extend slightly further in a downwards direction than the arms. The flaps 60 are formed of transparent material. This allows a user to be able to view the locations of the arms 55, 56 relative to the indents 51, 52, which may help them to locate the supplemental device 2 correctly on the injection device 1. Figure 8 shows the location of the left indent 52 in dotted form, to highlight the location of the arms, 55, 56 as well as the indents 51, 52, although the arms are not shown in this view.

In order to mate the supplemental device 2 with the injection device 1, the user first arranges the supplemental device 2 with respect to the injection device 1 as shown in Figure 10, and then applies a force downwards on the supplemental device 2 while at the same time applying a force upwards on the injection device 1. This places force on the protuberances 53, 54, and thus the right and left arms 55, 56. As the injection device 1 and the supplemental device 2 move closer together, the force results in the arms being moved apart, against the resilience of the spring 67. This causes the spring

67 to apply a reaction force, which resists entry of the injection device 1 into the injection device receiving channel 58. However, when the protuberances 53, 54 reach the location on the injection pen 1 at which they are directly in line with the longitudinal axis of the injection device 1, the reaction force supplied by the spring 67 ceases to increase upon further movement of the injection device 1 and the supplemental device 2 together. After this point, the movement of the injection pen 1 into the injection device receiving channel 58 is aided by the resilience of the spring 67.

After some further movement, the protuberances 53, 54 become aligned with the left and right indent 51, 52 and, due to the resilience of the spring 67, become engaged with the indents. Engagement provides haptic and audio feedback as the protuberances 53, 54 click or snap into the indents 51, 52. The feedback is enhanced by the force provided by the resilience of the spring 67. Once the protuberances 53, 54 are mated with the indents 51, 52, there is significant resistance to further movement of the supplemental device 2 relative to the injection device 1, due in part to the corresponding shapes of the protuberances 53, 54 and the indents 51, 52 and due in part to the biasing together of the arms 55, 56 by the spring 67.

If when the supplemental device 2 and the injection device 1 are moved together one of the indents 51, 52 is higher than the other, one of the protuberances 53, 54 will engage with the higher one of the indents before the other one of the protuberances reaches the other indent. In this case, the protuberance and indent that first meet become engaged, and present significant resistance to further movement of that protuberance relative to that indent. In this case, the tendency is naturally for the injection device 1 to be rotated relative to the supplemental device such that the other indent meets the other protuberance. Once the other indent meets the other protuberance, they mate together and considerable resistance is presented against further movement of the injection pen 1 relative to the supplemental device 2. In the scenario in which one of the protuberances meets an indent before the other protuberance meets its respective indent, the experience of the user is such that the injection pen 1 and the supplemental device 2 seem to move together initially with little or no rotation. Haptic and audio feedback is then provided when the first protuberance meets the corresponding indent,

and after this point the injection device 1 seems to roll into place within the injection device receiving channel 58 until the other protuberance is received in the other indent, at which point further haptic and audio feedback is provided to the user.

Once the protuberances 53, 54 are mated in the indent 51, 52, the injection device 1 is fully located within the injection device receiving channel 58 as shown in Figure 12. Here, it will be seen that the outermost surface of the display window 13 is generally aligned with a lowermost surface of the upper part of the supplemental device 2. This supplemental device 2 is shaped such that the injection device 1 fits snugly within the injection device receiving channel 58 and there are multiple points or areas of contact between the exterior surface of the housing 10 of the injection device 1 and the lowermost surface of the supplemental device 2 when the supplemental device and the injection pen 1 are in this relative position. Even in the absence of the mating of the protuberances 53, 54 with the indents 51, 52 at this point, the user would notice that there is a natural tendency for the injection pen 1 to sit at this location within the supplemental device 2.

When the supplemental device 2 is located with respect to the injection pen 1 such that the right and left protuberances 53, 54 are located within the right and left indents 51, 52 respectively, the locating rib 70 is engaged within the locating channel 71. Correct alignment of the supplemental device 2 with respect to the injection device 1 is thus provided in two ways: firstly, by the location of the locating rib 70 within the locating channel 71 and secondly by the locating of the protuberances 53, 54 within the indents 51, 52.

In the event that the user places the supplemental device 2 onto the injection pen 1 at a location such that the supplemental device 2 is slightly at the right of the position shown in Figure 8, the locating rib 70 does not fit within the locating channel 71. In this case, the supplemental device 2 is prevented from being located fully over the injection pen 1 by the locating rib 70 resting against a surface of the supplemental device 2 that is in some way distal from the correct location within the locating channel 71. However, in this position, the ends of the protuberances 53, 54 have passed the halfway point of the

circumference of the housing 10 of the injection device 1 and thus the spring 67 results in the injection device 1 being biased towards the supplemental device 2 so as to be located within the injection device receiving channel 58. A user would know that the supplemental device 2 had not mated correctly with the injection pen 1 because they would not have received any haptic feedback from the mating of the protuberances 53, 54 with the indents 51, 52. They would also notice that the end of the supplemental device that is closest to the dosage knob 12 was separated from the injection pen 1 by a distance greater than the separation of the supplemental device 2 from the injection pen 1 at the end of the supplemental device 2 distal from the dosage knob 12. In this situation, the user can engage the supplemental device 2 and the injection pen 1 simply by exerting a force against the supplemental device 2 and the injection pen 1 such as to move the supplemental device 2 leftwards in the direction shown in Figure 8. This can be achieved in a one-handed fashion or in a two-handed fashion. As the supplemental device 2 and the injection device 1 move relative to one another, the locating rib and the locating channel become more and more engaged. The spring force provided by the spring 67 may assist relative movement of the supplemental device 2 and the injection device 1 in this manner. As the locating rib 70 and the locating channel 71 become more engaged, the end of the supplemental device 2 that is closest to the dosage knob 12 moves down towards the injection device 1. This movement continues until the locating rib 70 is completely within the locating channel 71, at which point the right and left protuberances 53, 54 also engage with the right and left indents 51, 52 respectively. At this point, haptic feedback is provided by the mating of the protuberances 53, 54 with the indents 51, 52 and the user can determine that the supplemental device 2 and the injection device 1 are properly located with respect to one another.

If the user locates the supplemental device onto the injection pen 1 such that the supplemental device is to the left of the position shown in Figure 8, mating between the supplemental device 2 and the injection pen 1 will not occur. In this case, the locating rib 70 will not prevent the supplemental device 2 from being located flat against the injection pen 1. A user, noticing this, will know that the supplemental device 2 is located too far from the dosage knob 12. The user can engage the supplemental device 2 with the injection pen 1 simply by moving the supplemental device 2 relative to the injection



device 1 such as to move the supplemental device 2 rightwards in the direction shown in Figure 8.

If the locating rib 70 is aligned with the locating channel 71 when the end of the locating rib 70 that is closest to the display window 13, the smallest end of the locating rib 70 will enter the mouth, being the large open end, of the locating channel 71. At this stage, the supplemental device still is located against the surface of the injection device 1, with the injection device 1 being fully located within the injection device receiving channel 58. Because of the action of the spring 67, the injection device 1 is biased into the injection device receiving channel 58 against the supplemental device 2 at this stage.

If the locating rib 70 and the locating channel 71 are not exactly aligned, the narrowest end of the locating rib 70 will engage with a side of the locating channel. Further relative movement of the supplemental device 2 and the injection device 1 in a longitudinal direction results in a reactive force being applied between the locating rib and a wall of the locating channel 71, biasing the supplemental device 2 and the injection device 1 towards being in full alignment. This occurs until the locating rib 70 is fully engaged within the locating channel 71, at which point the right and left protuberances 53, 54 also engage with the right and left indents 51, 52. At this point, the supplemental device 2 and the injection device 1 are fully engaged with one another.

The supplemental device 2 is provided with a closure 68, which has a primary function of clamping the supplemental device 2 to the injection pen 1 when the two devices are mated with one another.

As best seen in Figures 13 and 14, the closure 68 has an innermost surface that coincides with the curved surface of an imaginary cylinder. The diameter of the cylinder is the same as the external dimension of the housing 10 of the injection device 1. As such, the closure 68 forms a snug fit against the lowermost part of the housing 10 of the injection device 1 when the supplemental device 2 is in place on the injection device 1.

The closure 68 is moveable between an open position, shown in Figure 13, and a closed position, shown in Figure 14.

As can be seen in Figure 8, the closure 68 is located next to the arm protecting walls 60, in a direction opposite the arm protecting walls 60 to the dosage knob 12. The closure 68 has a dimension in a longitudinal axis of the injection pen 1 that is approximately 60% of the length dimension of the supplemental device 2. In other examples, the length of the closure 68 in a longitudinal direction of the injection pen 1 may take a value anywhere between 30 and 80% of the length of the supplemental device 2, and preferably between 40 and 70% of the length of the supplemental device 2.

The material of the closure 68 has a generally uniform thickness. As such, the external surface of the closure 68, that is the surface that is furthest from the longitudinal axis of the injection pen 1 when the supplemental device 2 is mated with the injection pen 1, is generally cylindrical, or at least takes the form of part of a cylinder.

The closure 68 is provided with two cutaways 72, 73. The cutaways 72, 73 extend from an edge of the closure 68 that is furthest from the shaft 59 of the hinge formed at the other side of the supplemental device 2. The cutaways 72, 73 extend from this edge in a direction that is generally circumferential with respect to the injection pen 1. The length of the cutaways is approximately equal to 1/6 or 1/5 of the circumference of the circle on which the closure 68 generally lies. The cutaways 72, 73 define a tab 61. The tab 61 is connected to the main part of the closure 68 at a location between the lowermost ends of the cutaways 72, 73. A free end 63 of the tab 61 is located between the uppermost ends of the cutaways 72, 73. As is best seen in Figure 9, the free end 63 of the tab 61 is curved so as to extend away from the longitudinal axis of the injection pen 1 by a greater extent at a point that is central between the cutaways 72, 73. This allows a user better to be able to locate a digit on the free end 63 of the tab 61 so as to be able to pull the free end 63 in a direction that is downwards and leftwards in Figure 14.

On the inside surface of the tab 61 is provided a latching edge 64, which is best seen in Figures 9, 13 and 14. The latching edge 64 is provided at a junction between a latching face and another face. The latching edge 64 extends for the width of the tab 61. The latching face is in a plane that extends approximately radially with respect to the longitudinal axis of the injection 1 when the closure 68 is in the closed position, as shown in Figure 14. In this position, the latching edge 64 is engaged with a latch engaging face 66 that is provided as a part of the uppermost portion of the supplemental device 2, i.e. is provided as a portion of the supplemental device 2 that is not part of the closure 68. The latch engaging face 66 is provided in a plane that is generally the same orientation as the plane of the latching face when the closure 68 is in the closed position.

When the user has mated the supplemental device 2 onto the injection pen 1, in particular mating the locating rib 70 within the locating channel 71 and locating the protuberances 53, 54 within the indents 51, 52, the user may secure the supplemental device 2 to the injection pen 1. This is achieved by the user moving the closure 68 from the position shown in Figure 9, in which the injection device receiving channel 58 is open for inclusion of the injection pen 1 therein, and rotating the closure 68 around the shaft 59 of the hinge so as to move the free end 63 of the tab 61 towards the latch engaging face. Movement continues until contact is made between the innermost part of the latching edge 64 against a guide surface 65, which is located just beneath (as shown in the Figures) the latch engaging face 66. The guide surface 65 is angled approximately tangentially to the outside surface of the housing 10 of the injection pen 1.

At this point, the tendency of the closure 68 to adopt the shape shown in Figure 13 provides a spring force between the end of the tab 61 and the guide surface 65. As the user exerts further force against the closure 68, the closure 68 deforms resiliently so as to increase the separation between the free end 63 of the tab 61 and the hinge 59. This allows the edge of the latching edge 64 to slide over the guide surface 65. This continues until the latching edge 64 becomes aligned with the edge between the guide surface 65 and the latch engaging face 66, at which point the latching edge 64 and the

latching face engage within the channel that is formed against the latch engaging face 66. At this point, the resilience of the closure 68 results in the latching edge 64 and the latch engaging face 66 becoming engaged with one another, and at this point the components are in the position shown in Figure 14. In this position, it will be seen that the innermost surface of the closure 68 is snug against the outermost surface of the housing 10 of the injection pen 1. At this point, the closure 68 ensures that the injection pen 1 is tightly contained within the injection device receiving channel 58 and is held in place by the closure 68.

It will be appreciated that this arrangement prevents movement of the injection device 1 relative to the supplemental device 2 in the plane of Figure 14.

Movement of the supplemental device 2 along the longitudinal axis of the injection pen 1 is inhibited by the mating between the protuberances 53, 54 and the indents 51, 52. Additionally, movement of the supplemental device 2 in a rightwards direction as shown in Figure 8 is further prevented by the locating rib 70 acting against the body 20 of the supplemental device 2.

In some embodiments, the locating rib 70 and the locating channel 71 are absent. In these embodiments, the correct alignment between the supplemental device 2 and the injection pen 1 is provided by mating of the protuberances 53, 54 and the indents 51, 52.

In some other embodiments, the right and left arms 55, 56 and the protuberances 53, 54 are absent. In these embodiments, the correct alignment between the supplemental device 2 and the injection device 1 is provided by the locating rib 70 and the locating channel 71.

Of course, other alternative arrangements for ensuring a correct relative position between the supplemental device 2 and the injection pen 1 will be envisaged by the skilled person, and all such alternatives are within the scope of the invention except when explicitly excluded by the language of the claims.

Also, the skilled person will be aware of alternative securing arrangements, for instance clamping, the supplemental device 2 to the injection pen 1 once the correct relative position has been attained. Such alternatives include various other latching mechanisms involving a resilient component, such as a tab or an arm, and no complicated moving parts. Other such embodiments involve more complicated moving parts, for instance clamps with twist-to-lock mechanisms, tension clips and other such mechanisms. A hinge is a relatively simple way of connecting the main body of a supplemental device with a closure part, although alternative connection arrangements will be envisaged by the skilled person. Suitable connection arrangements may include slide mechanisms, clips, etc.

Fig. 15 is a cross-sectional view through the supplemental device 2 and the injection pen in a direction perpendicular to the axis of the injection pen 1. The cross-section is through the OCR reader 25, which is in the form of a camera. The camera 25 may also be called a sensor. Fig. 15 is not a true cross section in that third and fourth LEDs 29d, 29c, which are beyond the cross-section, are visible.

In Fig. 15 it can be seen that the dosage window 13 is of even thickness in cross-section and has a shape that forms part of a cylindrical annulus. The axis of the cylinder on which the dosage window 13 falls is the axis of the injection pen 1. The dosage window 13 may be slightly conical in the axial direction.

In Fig. 15, the supplemental device 2 is engaged with the injection pen 1, forming a snug fit therewith. Moreover, the supplemental device 2 and the injection pen 1 are aligned correctly, by virtue of the mating of the protuberances 53, 54 in the indents 51, 52 and the mating of the alignment rib 70 and the alignment channel 71. In this position, the camera 25 is directed at the dosage window 13.

Interposed between the camera 25 and the dosage window 13 is a protection window 80. The window 80 is shown in Fig. 16 and Fig. 18 also. As best seen from Fig. 15, the protection window 80 includes a lowermost surface that falls on the curved surface of a

cylinder having an axis aligned with the axis of the injection pen 1. The uppermost surface of the protection window 80 has a smaller radius. Thus, the protection window 80 has a greater thickness at its central part, which is in the path directly between the camera 25 and the axis of the injection pen 1, than it does at its edges. Thus, the protection window 80 has optical power. The protection window 80 is configured such that it forms part of the imaging system of the camera 25, along with the lens 25a. The lens 25s in these embodiments has two lenses, referred to as a lens for ease of explanation. The optical power of the protective window 80 can be seen also in the end view of the Fig. 16a and in the cross-section of Fig. 16b. The optical power of the protection window 80 allows a short track length and contributes to a compact arrangement.

The protection window 80 may be formed of any suitable optically transparent material. For instance, the protection window is formed of optics grade plastics, for instance optics grade polycarbonate or PMMA (polymethyl methacrylate acrylic).

At the left edge of the window 81 is provided a feature that connects with a left window support 83 that forms part of the body 20 of the supplemental device 2. A feature 82 on the right edge of the window is similarly configured to rest against a right window support 84 that forms part of the body 20 of the supplemental device 2. The left and right window supports 83, 84 serve to support the protection window 80 in a correct location with respect to other components of the supplemental device 2. The protection window 80 includes features at the left and right ends of the window, as shown in Fig. 16b, that serve to allow mechanical coupling with features of the supplemental device 2 and which are not relevant to the optical system, so are not described here.

The protection window 80 is sealed with respect to the body. This prevents the ingress of dirt, dust and other debris into the body 20 and thus helps to maintain correct operation of the camera 25 and other parts of the optical system. Thus, the protection window 80 forms part of the mechanical configuration of the body 20 of the supplemental device as well as part of the optical system. This helps to allow compactness in the overall arrangement.

As is best seen in Fig. 1a, the dosage window 13 is not square with respect to the injection pen 1. Instead, the dosage window is at an angle, which allows the dosage sleeve 19 to provide numbers in a helical fashion, the numbers appearing in the dosage window 13 as the dosage dial 12 is rotated by a user and a dose is delivered. In the SoloStar injection pen produced by Sanofi, the dosage window 13 and the markings on the dosage sleeve 19 are inclined at 13 degrees.

As can be best seen from Figs. 17 and 18, the optical arrangement comprising the camera 25 and the first to fourth LEDs 29a-29d are skewed with respect to the main axis of the injection device 1. The optical components are skewed to be aligned with the skewed lumbar sleeve 19 and dosage window 13. In the case of a SoloStar injection pen, the amount of skew is 13 degrees.

As best seen from Fig. 17 and Fig. 18, the first to fourth LEDs 29a-29d are separated from the lens 25a of the camera 25. In this example, they are distributed around the lens 25a. The LEDs 29a-29d are configured to illuminate the dosage sleeve 19, so that markings on the dosage sleeve can be read by the camera 25. As can be seen best from Fig. 15, the LEDs 29a-29d are angled or tilted towards the centre of the dosage window 13. This provides more effective illumination of the dosage sleeve 19 and can improve overall efficiency of the illumination.

The field of view of the camera 25 covers the whole width of the dosage sleeve 19. The field of view of the camera 25 also covers a sufficient part of the length of the dosage sleeve 19 that markings provided on the dosage sleeve are captured by the camera 25 during operation. Illumination from the first to fourth LEDs 29a-29d passes through the protection window 80 and the dosage window 13 of the injection pen 1 to illuminate the dosage sleeve 19, on which dose number markings are present. The camera 25 is arranged to view the dosage sleeve 19, taking into account refraction caused by the protection window 80 and the dosage window 13. As mentioned, the protection window 80 is part of the imaging system of the camera 25.

The LEDs 29a-29d are arranged so as to achieve substantially uniform illumination of the dosage sleeve. This is achieved by using LEDs 29a-29d with substantially uniform illumination patterns within defined angular and spatial ranges. The LEDs 29a-29d are positioned so that, taking into account the optical effects of the protection window 80 and the dosage window 13, a uniform illumination pattern is obtained at the dosage sleeve 19.

Each of the first to fourth LEDs 29a-29d illuminates a portion of the dosage sleeve 19 including the whole of the quadrant of the dosage sleeve 19 that is closest to the respective LED 29 and including the centre point of the dosage sleeve 19, which is directly beneath the camera lens 25a. In some embodiments, each of the LEDs 29 may illuminate only their respective quadrant and extend slightly into neighbouring quadrants. In other embodiments, each of the LEDs 29 illuminates a greater proportion of the dosage sleeve. For instance, each LED may illuminate more than 60%, more than 70% or more than 80% of the dosage sleeve. The greater the area illuminated by each of the LEDs 29, the better is the illumination of the dosage sleeve 19.

Each of the LEDs 29 is positioned relatively distant from the camera lens 25 in the plane of the camera lens. The LEDs 29 lie approximately in the plane of the camera lens 25a, although as can be seen in Fig. 15 in this particular example the LEDs 29 lie slightly below the plane of the camera lens 25a. This contributes to the compactness of the supplemental device 2. It also prevents the absorbing of light through other device features such as a barrel of the camera lens 25a. Thus, also it contributes to better homogeneity and overall brightness level.

As can be seen from Fig. 17, the first to fourth LEDs 29a-29d are not located directly above the dosage window 13. Instead, they are located slightly to the side. This does not affect the optical arrangement because the LEDs 29a-29d have illumination patterns that extend towards the dosage window 13.



In other embodiments, the LEDs are not tilted and instead all radiate in a common direction from the plane in which they lie. In further embodiments, a light guide with outcoupling features is used. This can provide a more even illumination.

As can be best seen from Fig. 18, the protection window 80 extends between the LEDs 29a-29d and the dosage window 13. The protection window 80 covers all or substantially all of the area of the dosage window 13.

The LEDs 29 and the protection window 80 are arranged such that light paths meet boundaries between air and optical components at angles that are less than the angle of total internal reflection for the boundary. The protection window 80 is formed of a material that reflects relatively little light that is incident at angles less than the angle of total internal reflection.

For a given one of the LEDs 29a-29d, there will be a point on the lowermost surface of the dosage window 13 at which light could reflect directly onto the camera. For each LED 29, there is also a point on the uppermost surface of the dosage window at which light could reflect directly onto the camera 25. This reflected light can be termed reflex. Reflexes from the lowermost surface of the dosage window 13, which is the surface closest to the dosage sleeve 19, are more relevant to correct imaging by the camera 25. Reflexes are experienced because the dosage window 13 is not coated with a non-reflective coating. The dosage window 13 may be made of relatively low-cost polycarbonate, which usually has relatively reflective surfaces.

On the lowermost surface of the dosage window 13, there is a point where light from the fourth LED 29d would reflect to the camera lens 25a. This point may be termed the reflection point of the fourth LED 29d. At the reflection point of the fourth LED 29d, light from the LED 29d has passed through one boundary from air into the material of the protective window 80 and through another boundary from the material of the protective window 80 to air. Because the protective window 80 has an optical power, the direction of incidence of a ray of light on the uppermost surface of the dosage window 13 is different from the direction of the same ray when it left the fourth LED 29d. Light

arriving at the uppermost surface of the dosage window 13 is refracted again by the boundary between air and the dosage window 13 and continues towards the lowermost surface of the dosage window 13. From the reflection point of the fourth LED 29d, reflected light would be refracted at three boundaries provided by the uppermost surface of the dosage window 13 and the two surfaces of the protection window 80 before arriving at the camera lens 25a. As such, and because the protection window 80 has an optical power and because of refraction provided at the uppermost surface of the dosage window 13, the direction of travel of the reflected ray leaving the lowermost surface of the dosage window 13 is different to the direction of travel of the ray when it is incident on the camera lens 25a.

The reflection point for the fourth LED 29d is one where a first line perpendicular to the lowermost surface of the dosage window 13 lies in a first plane in which the light incident from the fourth LED 29d and the light reflected to the camera lens 25a also lie, and in which an angle from the first line to a second line that connects the light incident from the fourth LED 29d to the reflection point is the same as an angle from the first line to a third line that connects the reflection point to the light passing to the camera lens 25a.

There are two main sections to the central window part of the protection window 80, which will now be described with reference to Fig. 16d. The main sections will be referred to as a central portion and a periphery portion. The central portion is indicated by Rx and the periphery portion is indicated by Ry. The central portion Rx has a different optical power than the periphery portion. In these embodiments, the surface of the protection window 80 that is closest to the dosage window in use has a constant radius and the radius of the surface on the side of the protection window 80 that is closest to the camera 25 is different for the central portion Rx and the periphery portion Ry. However the converse may be true or there may be different radii on both surfaces. Here, Rx indicates the central portion and also indicates the radius of the surface closest to the sensor 25, and Ry indicates the periphery portion and also indicates the radius of the surface closest to the sensor 25.

Most or all of the central portion Rx lies on the optical path between the sensor 25 and the area of interest of the sleeve 19 that is visible through the dosage window 13. The periphery portion Ry does not lie on the optical path between the sensor 25 and the area of interest of the sleeve 19 that is visible through the dosage window 13.

However, some or all of the periphery portion Ry does lie on the optical path between the light sources 29 and the area of interest of the sleeve 19 that is visible through the dosage window 13. Consequently, the central portion Rx is part of the optical imaging system for reading the numbers visible on the part of the sleeve 19 that is visible in the dosage window 13, and the periphery portion Ry is not part of this optical imaging system. However, the periphery portion Ry is part of the optical system by which illumination of the sleeve 19 that is visible through the dosage window 13 by the light sources 29 is achieved. At least some of the central portion Rx also is part of this optical illumination system.

The central portion Rx forms a convex lens, which has a greater thickness at its centre than it does at its periphery. The periphery portion Ry may have no optical power at all, in that it may not converge or diverge incident light. Thus the central portion Rx and the periphery portion Ry have different optical powers.

The shape of the central portion Rx has an effect of reducing pin cushion distortion, as is described below. This is not true of the periphery portion Ry for two reasons: firstly, it has no optical power and secondly it is not part of the imaging optical path. However, the periphery portion Ry does assist in providing even illumination of the sleeve 19 by the light sources 29. This results because of the location of the periphery portion Ry in the optical illumination path between the light sources 29 and the sleeve 19 and because the periphery portion Ry is optically sound.

The provision of the periphery portion Ry with lower optical power than the central portion Rx (e.g. zero optical power compared to negative power) allows the protection window 80 to be formed with less material than would be possible if the same optical power was applied across the whole width dimension of the protection window. This can reduce the cost and weight of the supplemental device 2. Moreover, the thickness

of the centre of the protection window 80 is lower, for a given radius  $R_x$  and a given width of protection window 80, which can contribute to a more compact arrangement. The thickness of the material at the periphery portion  $R_y$  dictates the mechanical strength of the protection window 80 and is chosen such that the protection window 80 has a suitable mechanical strength.

In the absence of the central portion  $R_x$  of the protection window 80 as described above, the output of the camera 25 would experience pin cushion distortion. In the particular arrangement shown, there are two sources for the pin cushion distortion. The first is the optical system of the camera 25 and its lens 25a in conjunction with the dosage window 13. Pin cushion distortion results from the optical system in part from the short track length, i.e. the short distance between the camera 25 and the dosage window 13, and in part from the shape of the lens 25s. Secondly, pin cushion distortion results also from the curved shape of the sleeve 19. The pin cushion distortion that would be experienced in the absence of the central portion  $R_x$  of the protection window 80 is shown in Fig. 19a. This is the output of a camera viewing an even rectangular grid of squares. It will be seen that the grid is not rectangular in the camera output, but is pin cushion shaped.

The output of the same camera in the same situation but with the protection window 80 in place with the central portion  $R_x$  in the imaging optical path is shown in Fig. 19b. Here, it will be seen that the pin cushion distortion is significantly reduced, although still present to some degree.

Removal or reduction of pin cushion distortion is advantageous because it allows better performance by the OCR system 25. In particular, performance is better because the numerals/characters on the sleeve 19 in the dosage window 13 are more reliably detected by the OCR system 25 and/or are detected using fewer processing resources. Using fewer processing resources reduces power consumption. More reliable numeral/character detection results in improved operation of the supplemental device 2 and an improved user experience.

There are two main alternatives for the shape of the optical part of the protection window 80.

In a first alternative, the surface of the protection window 80 that is closest to the sensor 25 has a cylindrical shape. Because the surface of the protection window 80 that is closest to the sleeve 19 is also cylindrical, in this alternative the protection window 80 has a constant thickness along its length, which is the dimension shown in cross section B-B of Fig. 16f. This applies particularly to the central portion Rx, but it also applies to the periphery portion Ry. In the first alternative, the central portion Rx forms a cylindrical lens.

In a second alternative, the central part Rx of the protection window 80 is toric, and forms a toric lens. In this alternative, the protection window 80 has a thickness that is greatest at a point at or close to the middle part along its length, which is the dimension shown in cross section B-B of Fig. 16f, and tapers to lower thicknesses at distances further from the point where it has the greatest thickness. Advantageously the surface of the protection window 80 that is closest to the sleeve 19 is cylindrical and the surface that is closest to the camera 25 is curved, but the converse may be true or both surfaces may be curved in the length direction. This applies only to the central portion Rx; the periphery portion Ry does not have a toric lens shape.

A cylindrical lens, according to the first alternative, is simpler to make than a toric lens. The ability to remove pin cushion distortion is similar for a toric lens as for a cylindrical lens.

The transition between the central portion Rx and the periphery portion Ry may be a step transition, or it may be graded over a short distance. A step transition may provide better optical performance, but a graded transition may be simpler to manufacture.

The protection window 80 is formed of an optical plastic, for instance polycarbonate. This allows the protection window 80 to be made at low cost whilst allowing the optical

imaging system to function correctly (other materials have inferior optical properties and could reduce the effectiveness of the optical imaging system).

However, the use of optical plastic can introduce optical reflexes, which would reduce the effectiveness of the optical imaging system. Optical reflexes result from the refractive index variation from air. This is mitigated in the present embodiments through the application of an anti-reflective coating on the protection window 80. The anti-reflective coating may be applied to the surface that is closest to the camera 25. It may alternatively be provided to the surface that is closest to the sleeve 19. Alternatively, it may be applied to both of these surfaces.

By using an anti-reflective coating consisting of relatively few dielectric single layers, the coating can be made to be very stable under common environmental conditions. Here, the anti-reflective coating may consist of between three and five dielectric single layers. The shape of the reflective spectrum of this type can be described as a V-form spectrum.

Various alternatives will be apparent to the skilled person and all such alternatives are within the scope of the invention unless excluded by the scope of the claims.

For instance, instead of LEDs, any other suitable light sources may be used. Suitable light sources may include light bulbs, laser diodes and organic LEDs.

Although four light sources are included in the shown embodiments, in other embodiments there are one, two, five or more than five light sources. The choice of the number of light sources may depend on the particular light source type chosen, brightness, efficiency and cost requirements.

Also, although the protection window 80 is located close to the dosage window 13 when the supplemental device 2 is in position on the injection pen 1 in the embodiments above, they may instead be separated by a significant distance. Providing the protection window 80 close to the dosage window 13 contributes to providing a compact

arrangement. The provision of a compact arrangement is assisted by the provision of the protection window 80 as described above.

## Claims

1. A supplemental device for attachment to an injection device including a dosage window covering a sleeve on which dose values are marked, the supplemental device comprising:
  - a main body;
  - an arrangement for supporting the main body of the supplemental device in a predetermined positional relationship with the injection device;
  - a transparent protection window located at a surface of the main body that is aligned with the dosage window of the injection pen when in use; and
  - a sensor arrangement supported in the main body and having a sensor directed at the protection window,wherein the protection window is configured as a cylindrical lens or a toric lens with an optical power.
2. A supplemental device as claimed in claim 1, wherein the protection window is configured as a toric lens.
3. A supplemental device as claimed in claim 1, wherein the protection window is configured as a cylindrical lens.
4. A supplemental device as claimed in any preceding claim, wherein a first portion of the protection window is configured as a cylindrical or toric lens and wherein a second portion of the protection window has a different optical power to the first portion.
5. A supplemental device as claimed in any preceding claim, comprising an illumination arrangement comprising one or more sources of light, each of the one or more sources of light being directed at the protection window.
6. A supplemental device as claimed in any preceding claim, comprising an illumination arrangement comprising one or more sources of light, each of the one or more sources of light being directed at the protection window, wherein a first portion of



the protection window is configured as a cylindrical or toric lens, wherein a second portion of the protection window has a different optical power to the first portion, wherein the first portion of the protection window is in the optical path between the sensor arrangement and the dosage window of the injection pen when the device is in use, and wherein the second portion of the protection window is not in the optical path between the sensor arrangement and the dosage window of the injection pen when the device is in use but is in the optical path between the illumination arrangement and the dosage window of the injection pen when the device is in use.

7. A supplemental device as claimed in any preceding claim, comprising an illumination arrangement comprising two or more sources of light, each of the two or more sources of light being directed at the protection window, wherein the two or more sources of light are located on opposite sides of the sensor arrangement, wherein a central portion of the protection window is configured as a cylindrical or toric lens, wherein a periphery portion of the protection window has a different optical power to the central portion, wherein the central portion of the protection window is in the optical path between the sensor arrangement and the dosage window of the injection pen when the device is in use, and wherein the periphery portion of the protection window is not in the optical path between the sensor arrangement and the dosage window of the injection pen when the device is in use but is in the optical path between the illumination arrangement and the dosage window of the injection pen when the device is in use.

8. A supplemental device as claimed in any preceding claim, wherein the transparent protection window is formed of optical plastic.

9. A supplemental device as claimed in any preceding claim, wherein the transparent protection window is provided with an anti-reflective coating on at least one surface thereof.

10. A supplemental device as claimed in claim 9, wherein the anti-reflective coating comprises plural dielectric layers.

11. A supplemental device as claimed in claim 10, wherein the anti-reflective coating comprises between three and five dielectric layers.
12. A supplemental device as claimed in either preceding claim, wherein the protection window is sealed to the main body so as to prevent the ingress of material into the supplemental device around the protection window.
13. A system comprising a supplemental device as claimed in any preceding claim and an injection device.
14. A system as claimed in claim 13, wherein a surface of the protection window that is furthest from the sensor arrangement lies on a curved surface of an imaginary cylinder having an axis coincident with a longitudinal axis of the injection device and wherein the surface of the protection window that is furthest from the sensor arrangement lies in close proximity with a dosage window of the injection device when the supplemental device is installed on the injection device.
15. A supplemental device for attachment to an injection device including a dosage window covering a sleeve on which dose values are marked, the supplemental device comprising:
  - a main body;
  - an arrangement for supporting the main body of the supplemental device in a predetermined positional relationship with the injection device;
  - a transparent protection window located at a surface of the main body that is aligned with the dosage window of the injection pen when in use; and
  - a sensor arrangement supported in the main body and having a sensor directed at the protection window,wherein the protection window has an optical power.
16. A supplemental device as claimed in claim 15, wherein the protection window is configured as a toric lens.

17. A supplemental device as claimed in claim 15, wherein the protection window is configured as a cylindrical lens.
18. A supplemental device as claimed in claim 15, wherein a first portion of the protection window has the optical power and wherein a second portion of the protection window has a different optical power to the first portion.
19. A supplemental device as claimed in claim 15, comprising an illumination arrangement comprising one or more sources of light, each of the one or more sources of light being directed at the protection window.
20. A supplemental device as claimed in claim 15, comprising an illumination arrangement comprising one or more sources of light, each of the one or more sources of light being directed at the protection window, wherein a first portion of the protection window has the optical power, wherein a second portion of the protection window has a different optical power to the first portion, wherein the first portion of the protection window is in the optical path between the sensor arrangement and the dosage window of the injection pen when the device is in use, and wherein the second portion of the protection window is not in the optical path between the sensor arrangement and the dosage window of the injection pen when the device is in use but is in the optical path between the illumination arrangement and the dosage window of the injection pen when the device is in use.
21. A supplemental device as claimed in claim 15, comprising an illumination arrangement comprising two or more sources of light, each of the two or more sources of light being directed at the protection window, wherein the two or more sources of light are located on opposite sides of the sensor arrangement, wherein a central portion of the protection window has the optical power, wherein a periphery portion of the protection window has a different optical power to the central portion, wherein the central portion of the protection window is in the optical path between the sensor arrangement and the dosage window of the injection pen when the device is in use, and wherein the periphery portion of the protection window is not in the optical path between

the sensor arrangement and the dosage window of the injection pen when the device is in use but is in the optical path between the illumination arrangement and the dosage window of the injection pen when the device is in use.

22. A supplemental device as claimed in claim 15, wherein the transparent protection window is formed of optical plastic.

23. A supplemental device as claimed in claim 15, wherein the transparent protection window is provided with an anti-reflective coating on at least one surface thereof.

24. A supplemental device as claimed in claim 23, wherein the anti-reflective coating comprises plural dielectric layers.

25. A supplemental device as claimed in claim 24, wherein the anti-reflective coating comprises between three and five dielectric layers.

26. A supplemental device as claimed in claim 15, wherein the protection window is sealed to the main body so as to prevent the ingress of material into the supplemental device around the protection window.

27. A system comprising a supplemental device as claimed in claim 15 and an injection device.

28. A system as claimed in claim 27, wherein a surface of the protection window that is furthest from the sensor arrangement lies on a curved surface of an imaginary cylinder having an axis coincident with a longitudinal axis of the injection device and wherein the surface of the protection window that is furthest from the sensor arrangement lies in close proximity with a dosage window of the injection device when the supplemental device is installed on the injection device.

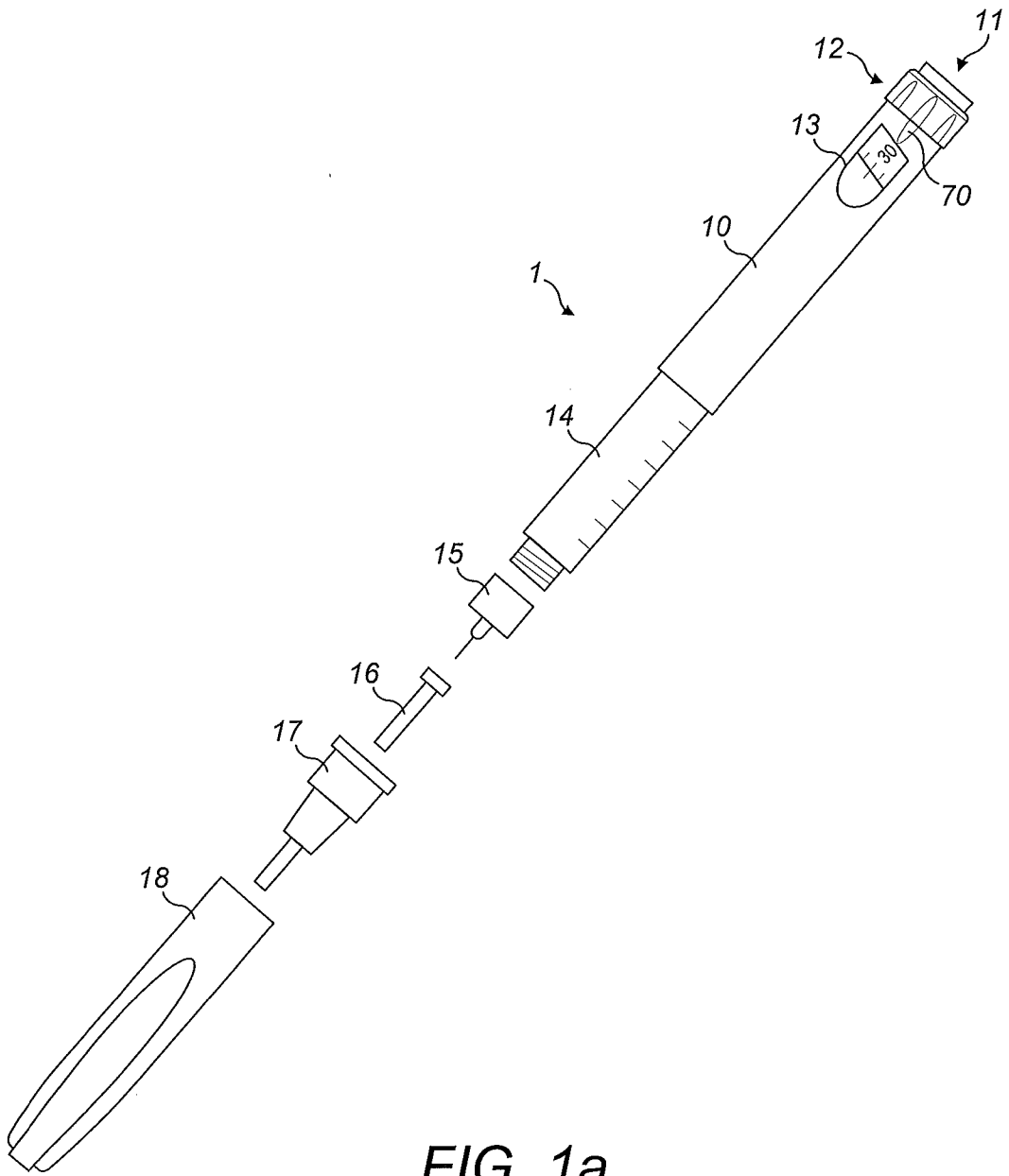

FIG. 1a

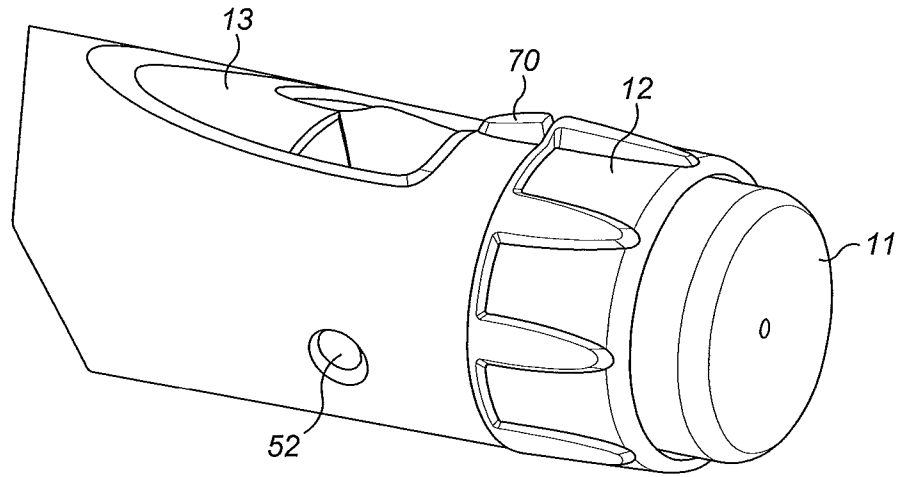

FIG. 1b

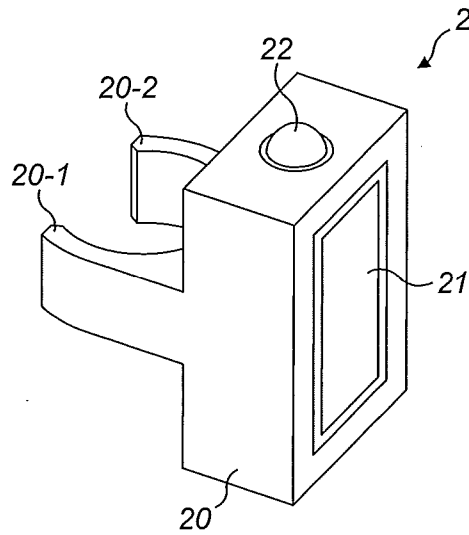

FIG. 2a

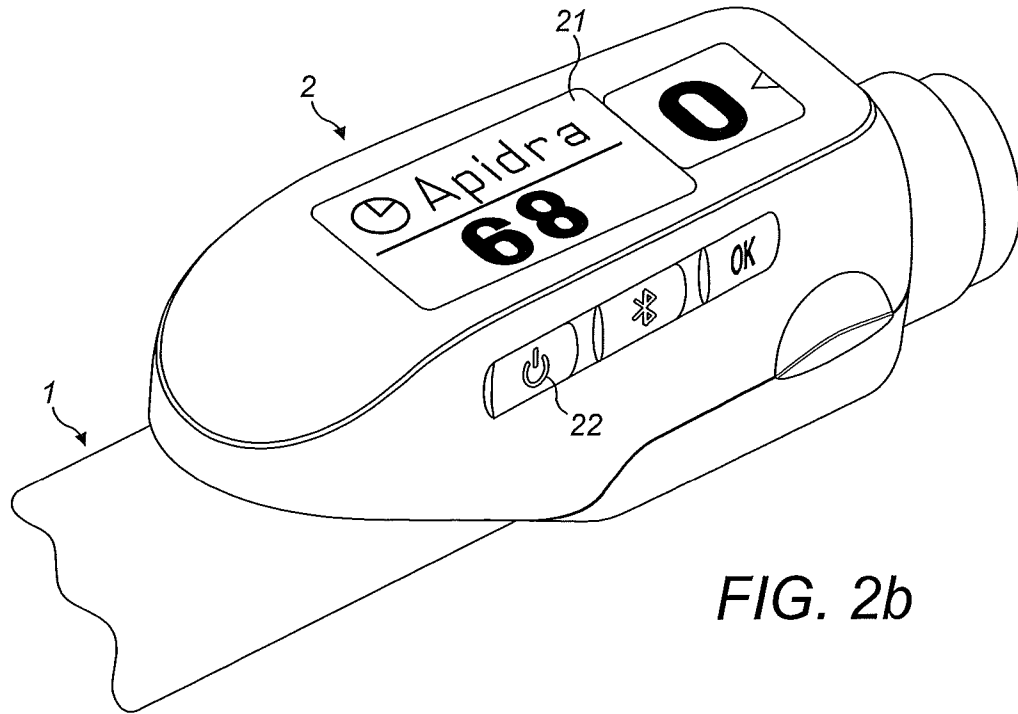

FIG. 2b

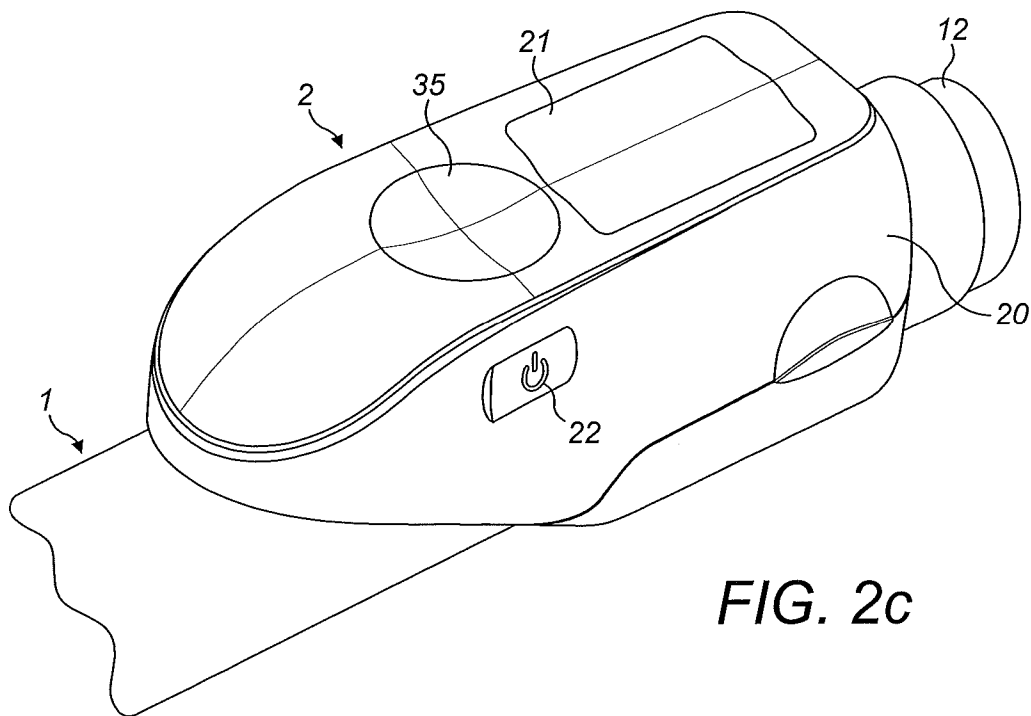

FIG. 2c

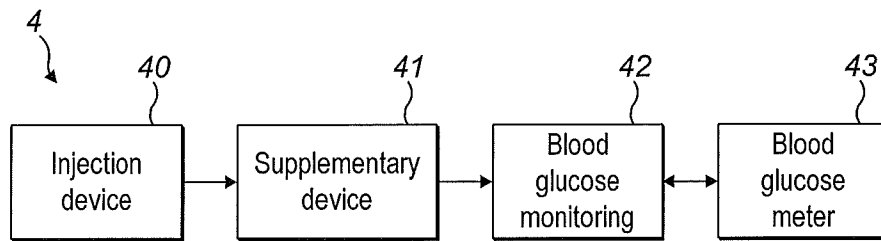

FIG. 3a

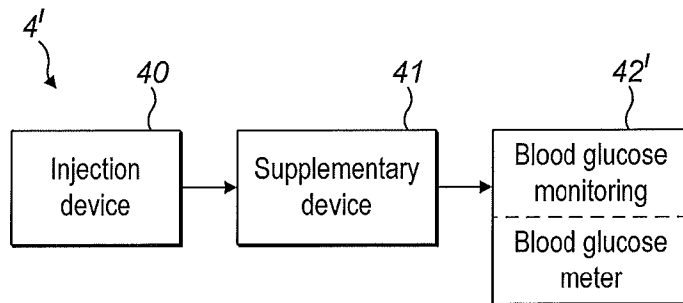

FIG. 3b



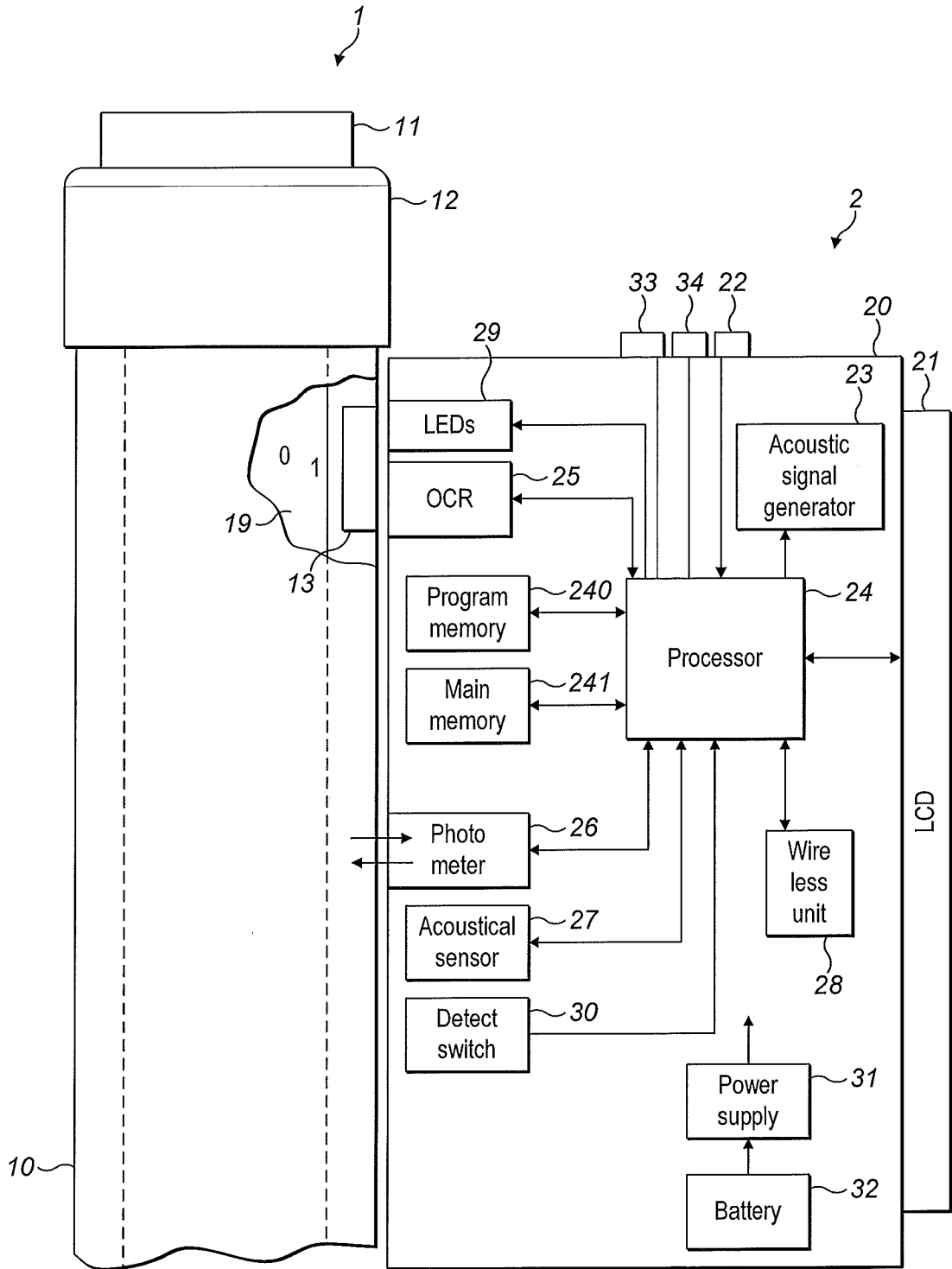

FIG. 4

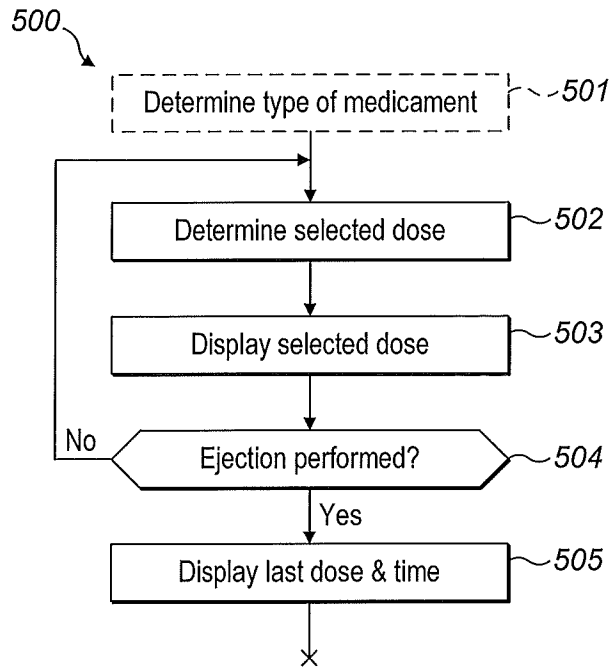

FIG. 5a

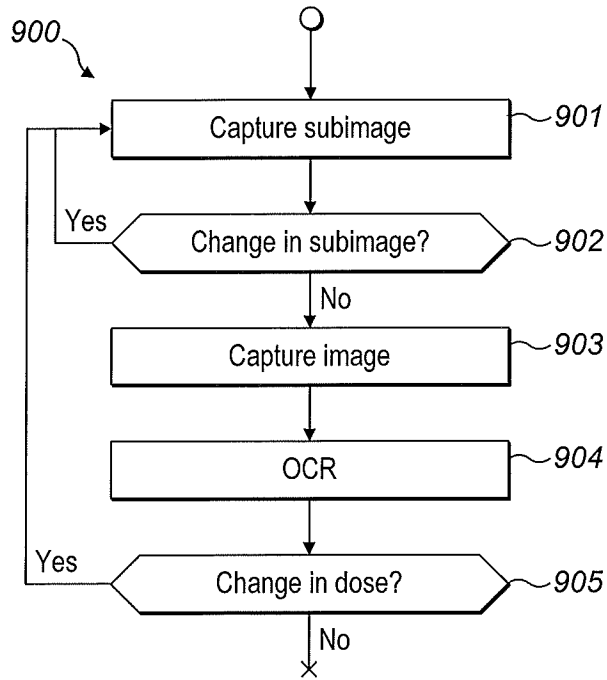

FIG. 5b

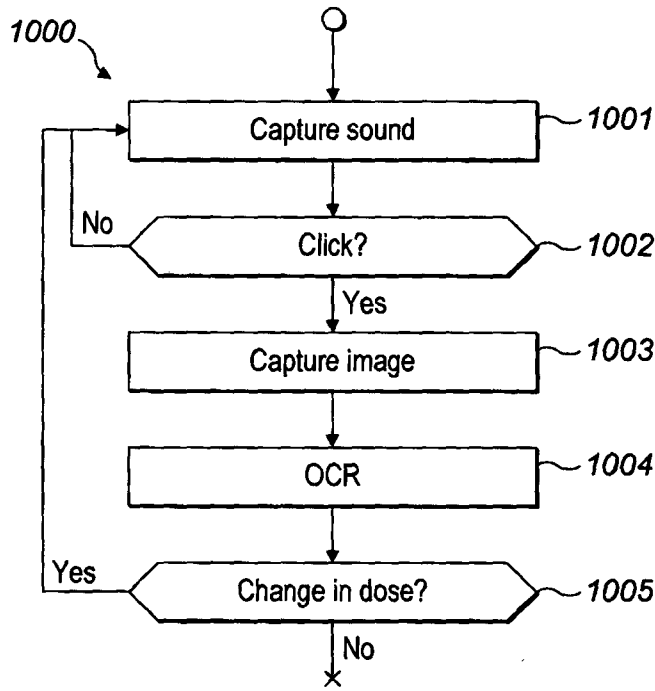

FIG. 5c

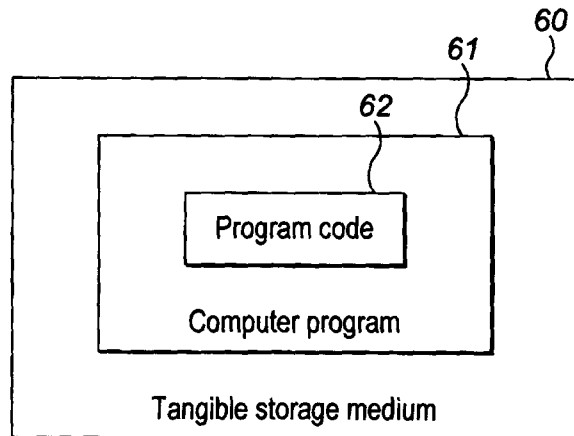

FIG. 6

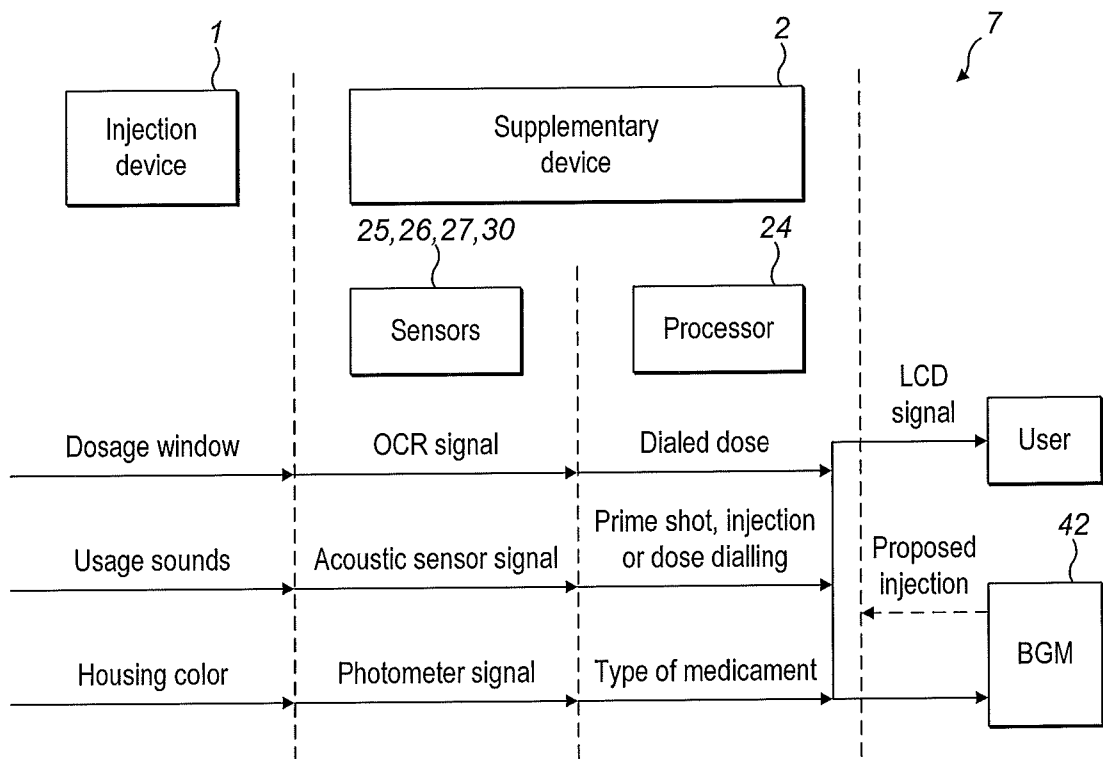

FIG. 7

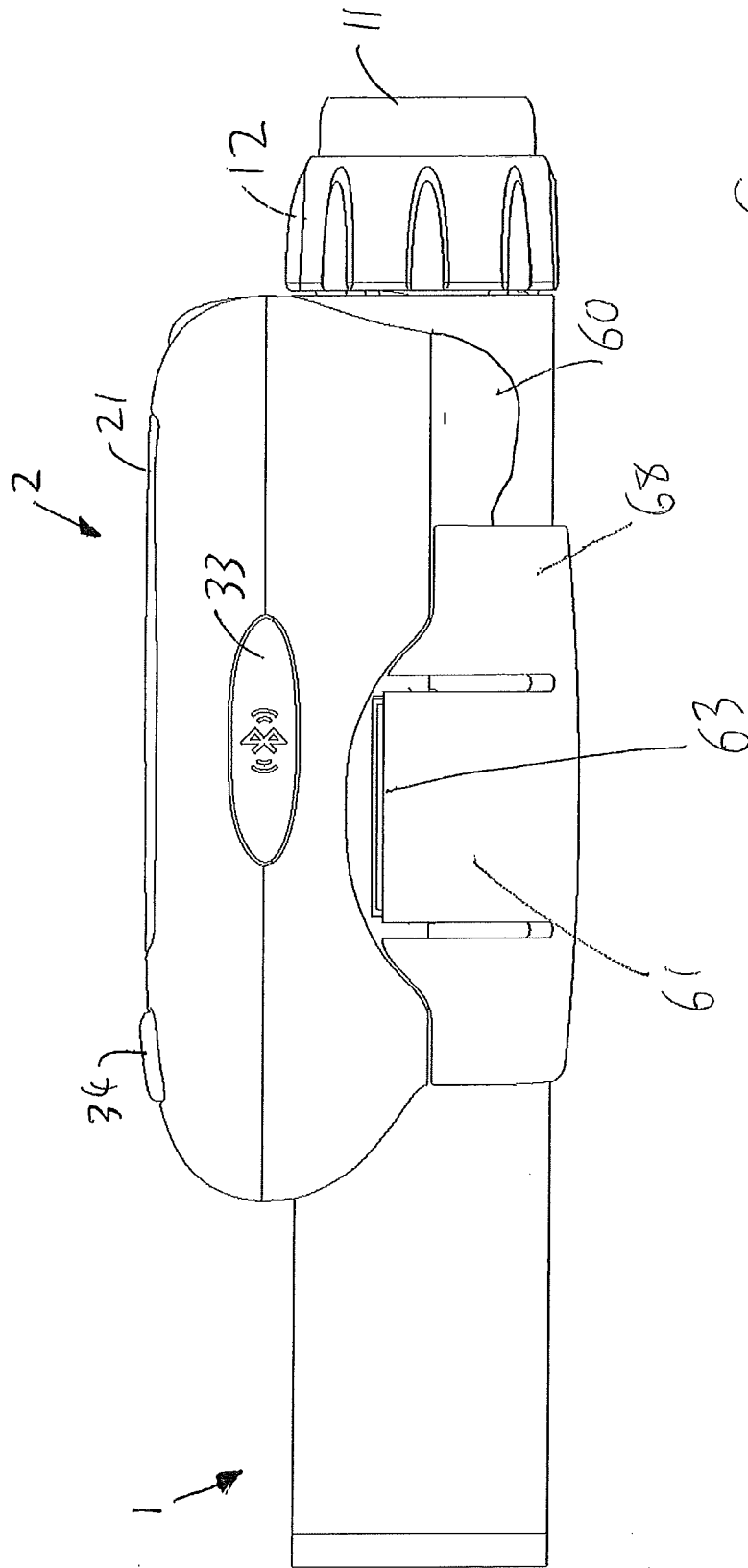

Figure 8

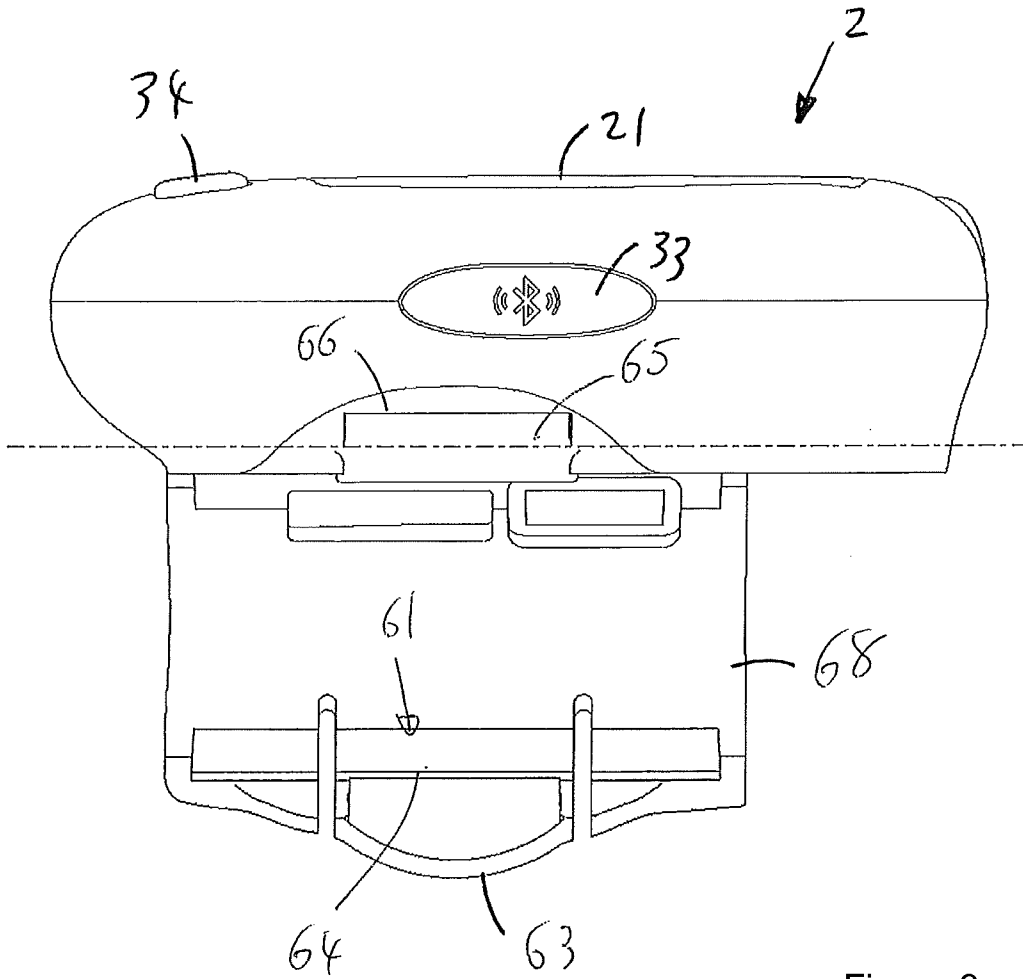

Figure 9

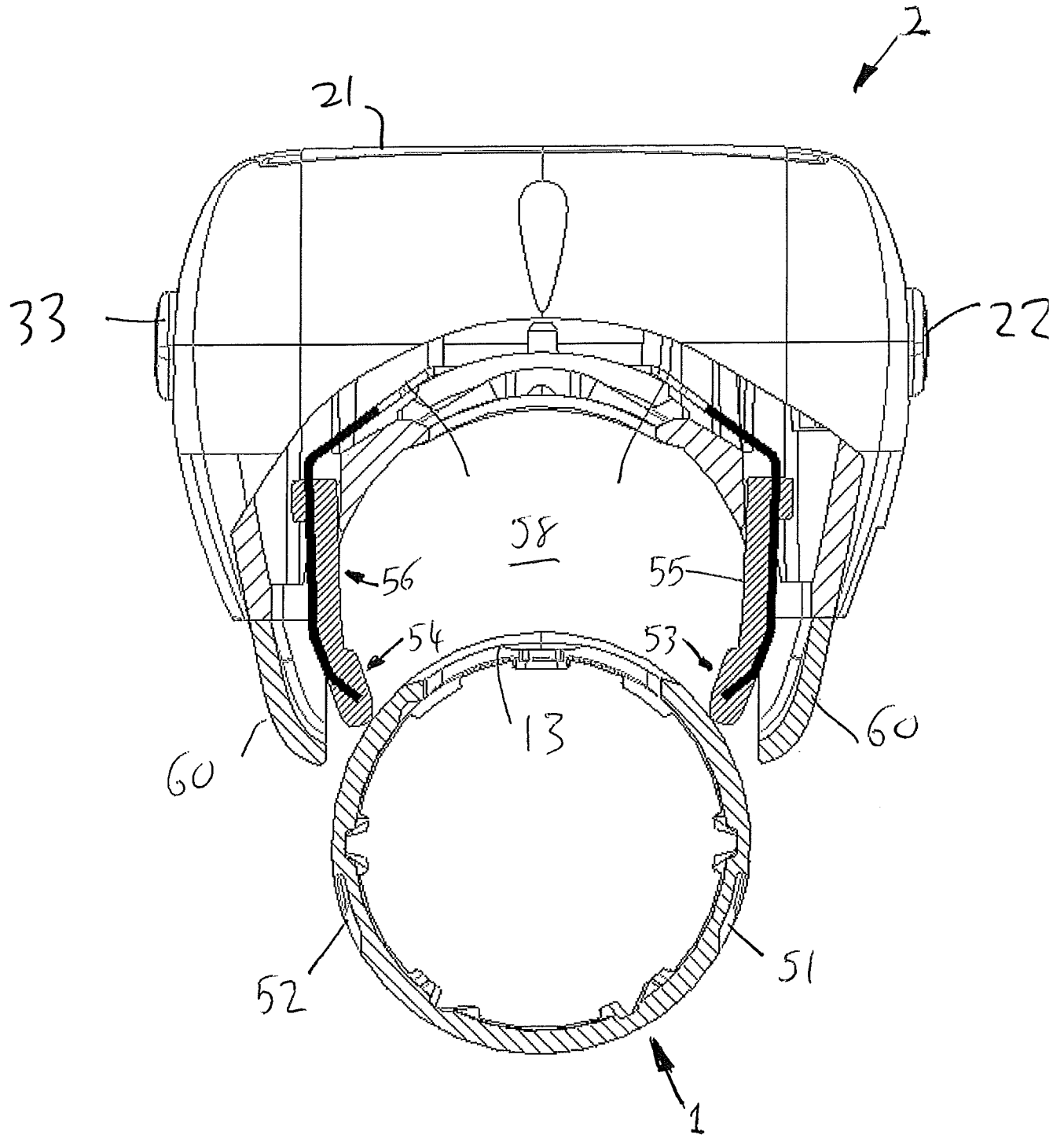

Figure 10

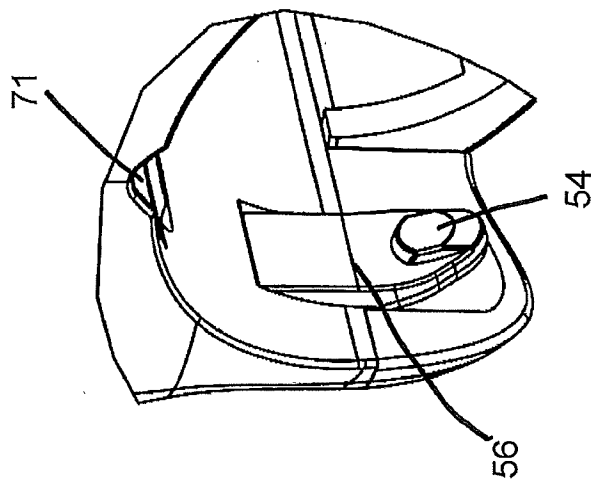

Figure 11a

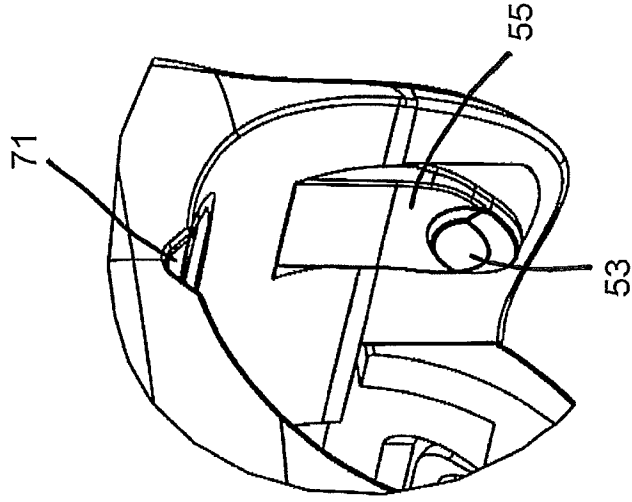

Figure 11b



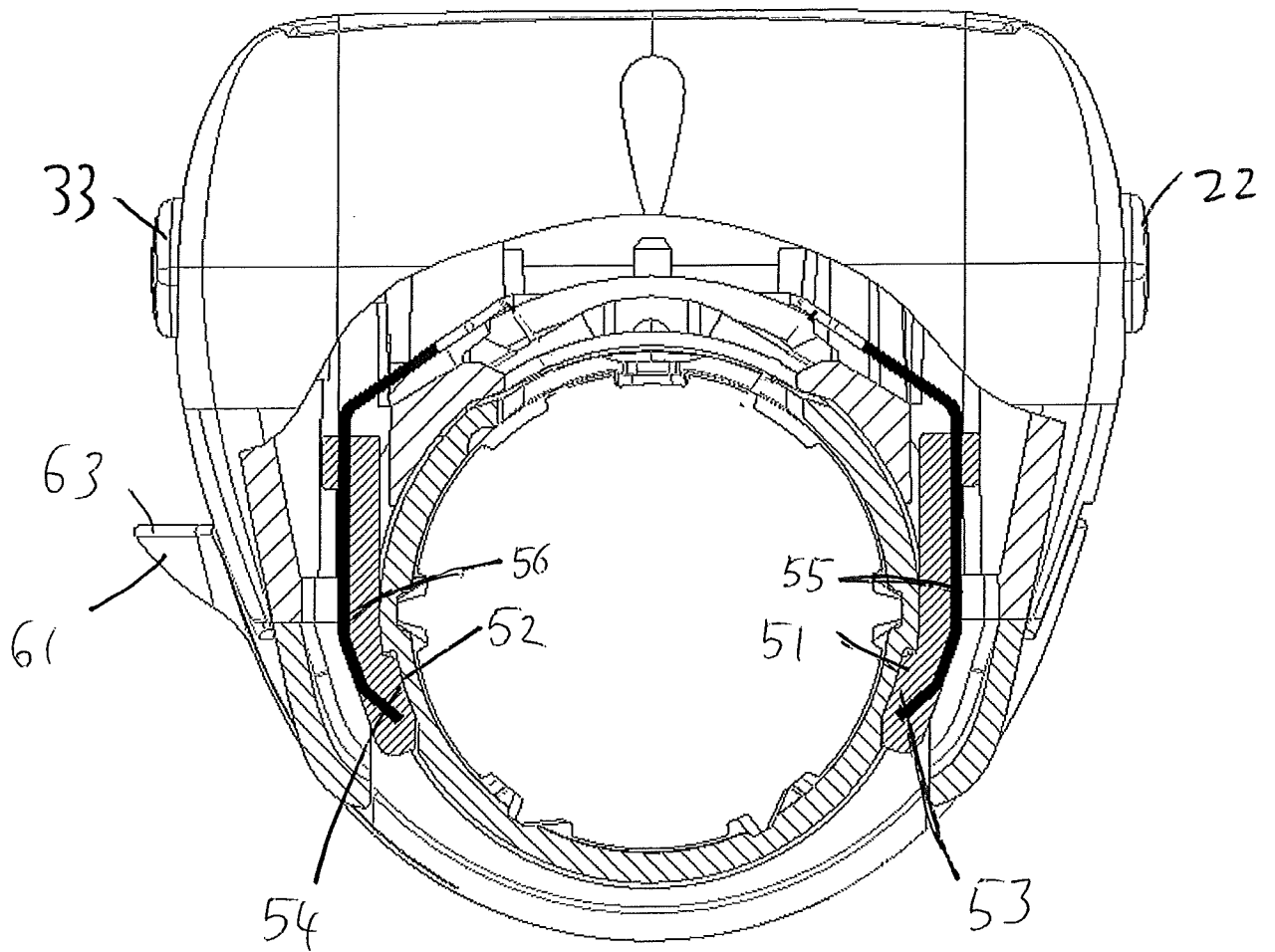

Figure 12

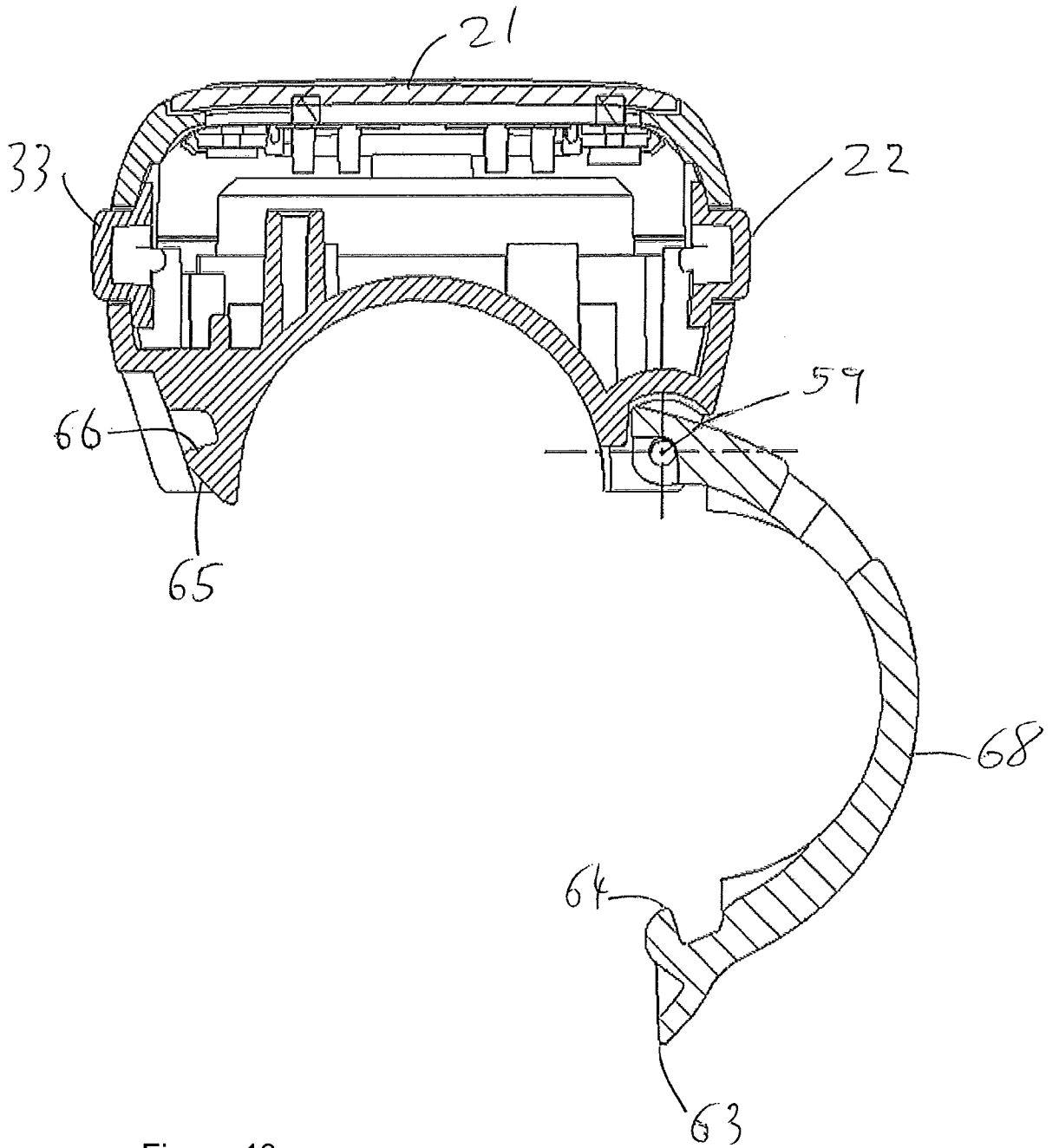

Figure 13

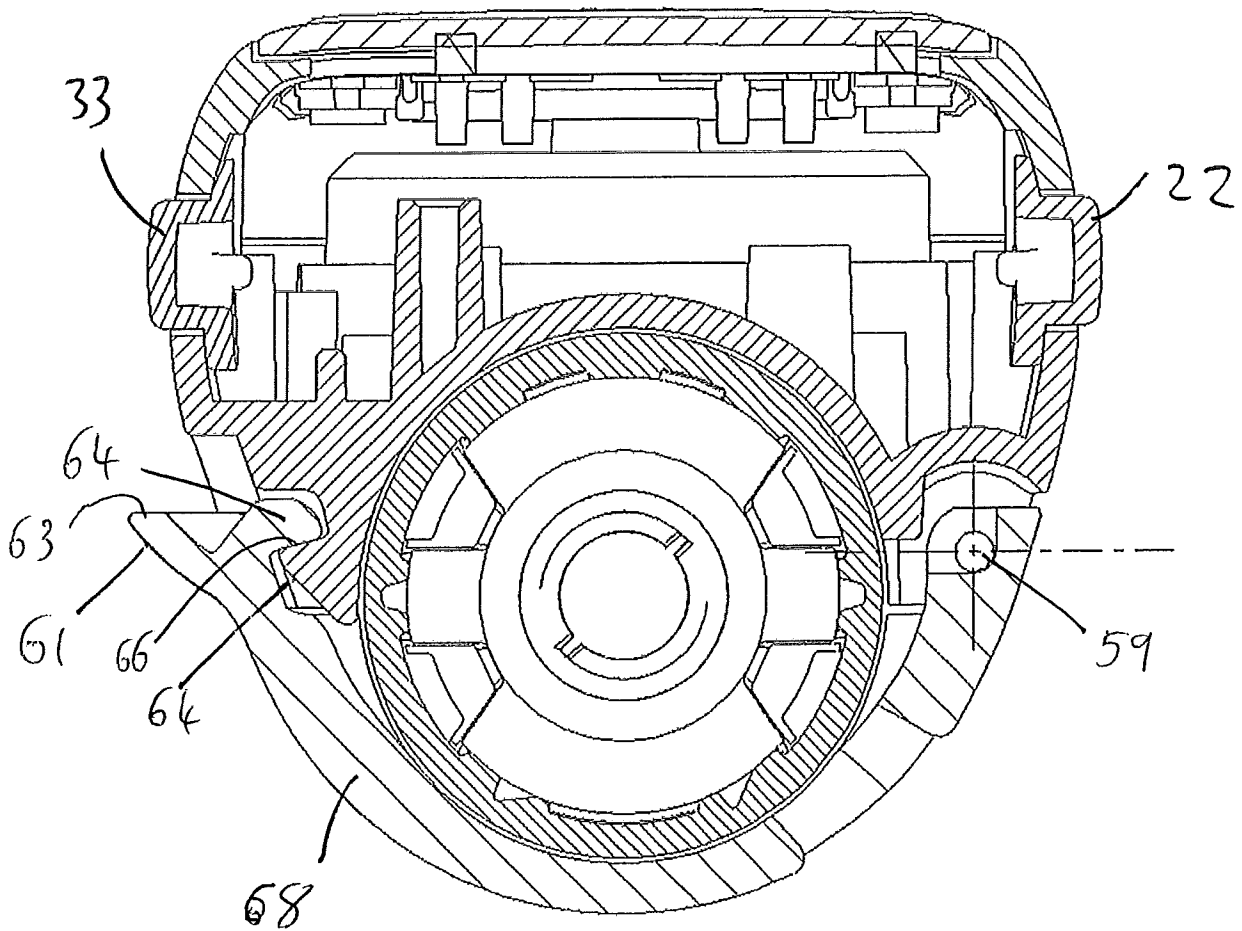

Figure 14

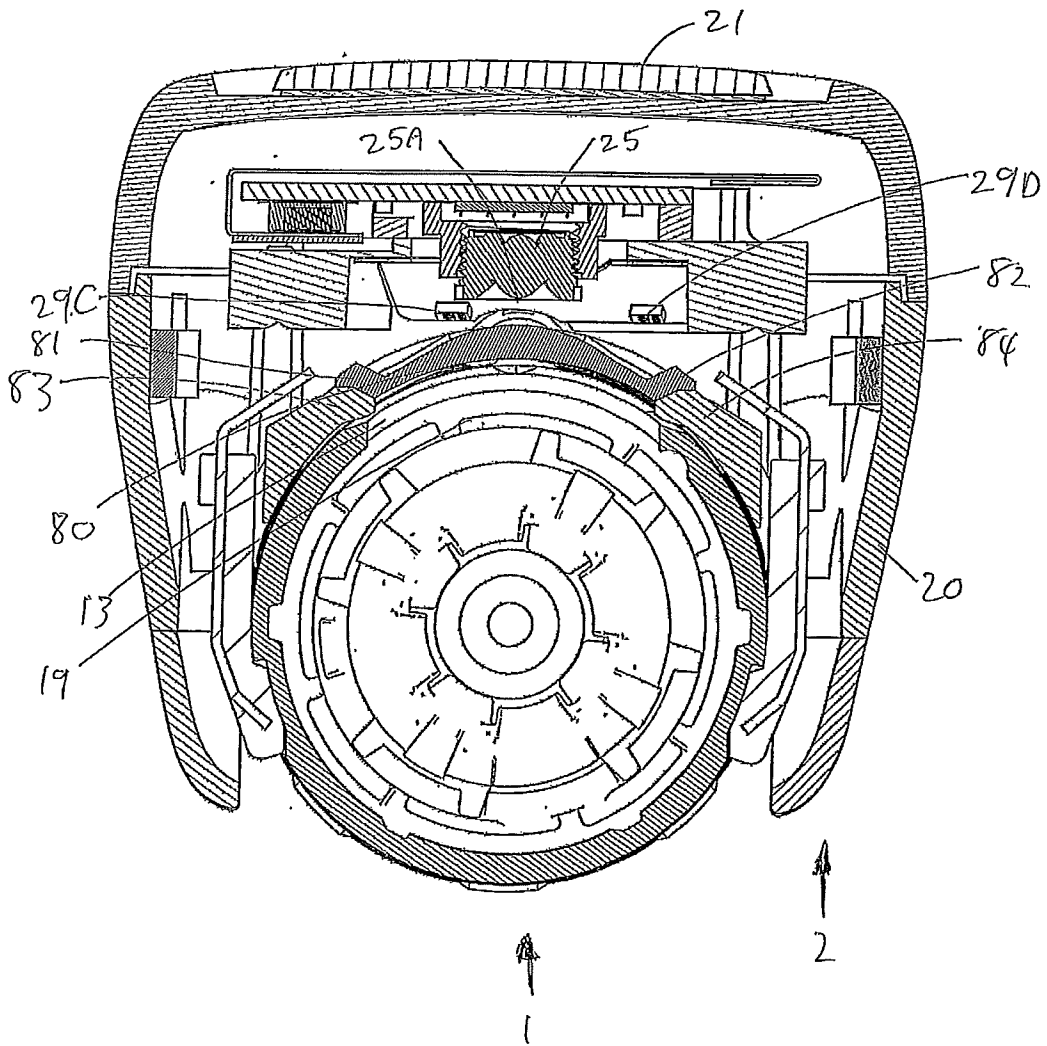

Figure 15

17/20

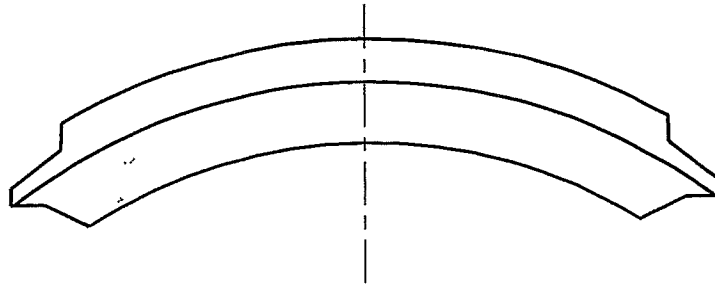

Fig. 16c

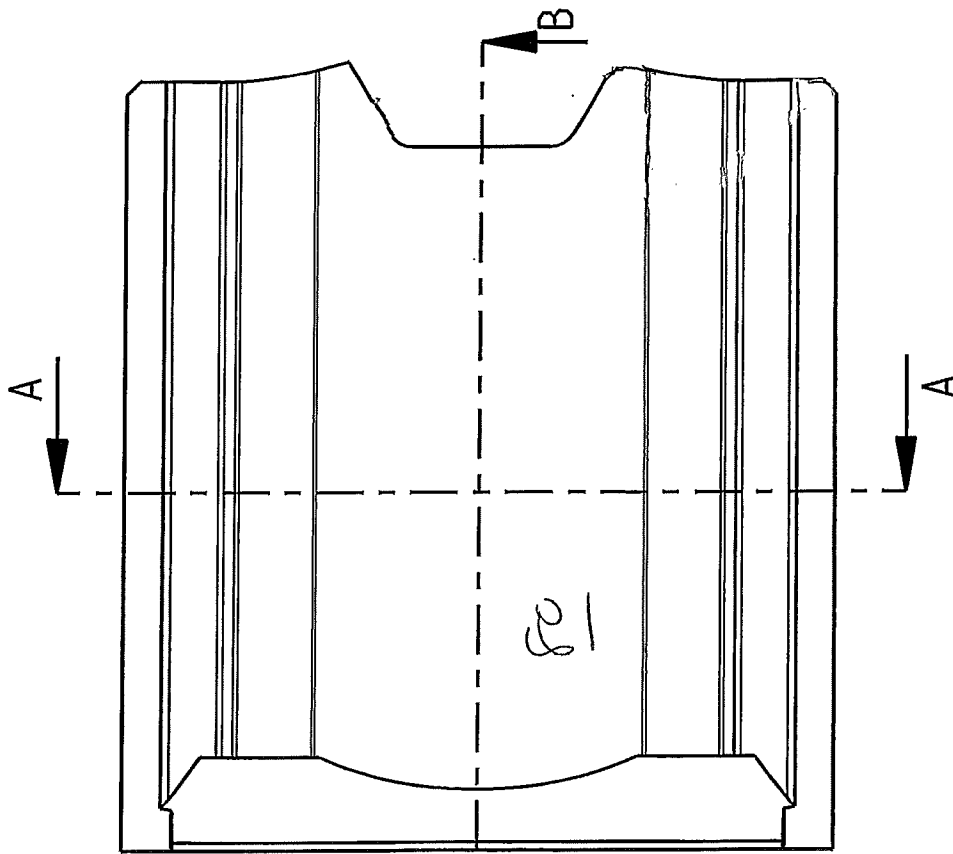

Fig. 16b

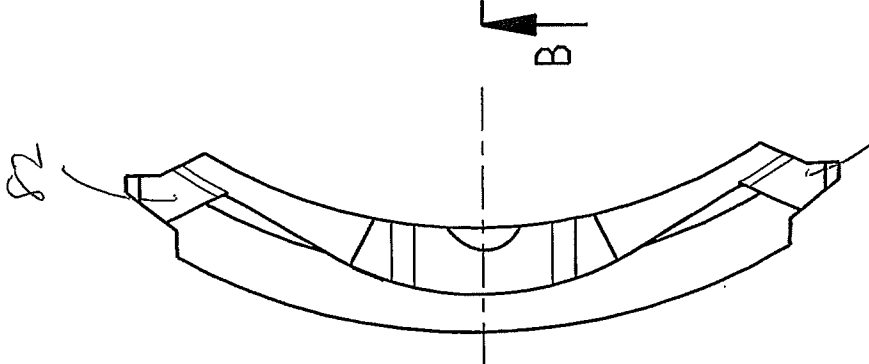

Fig. 16a

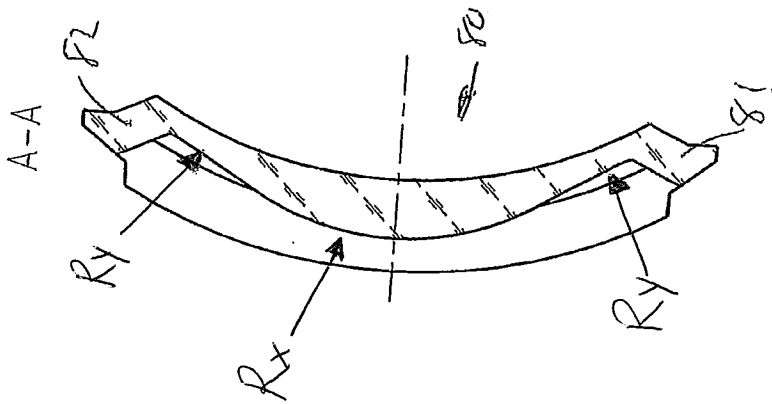
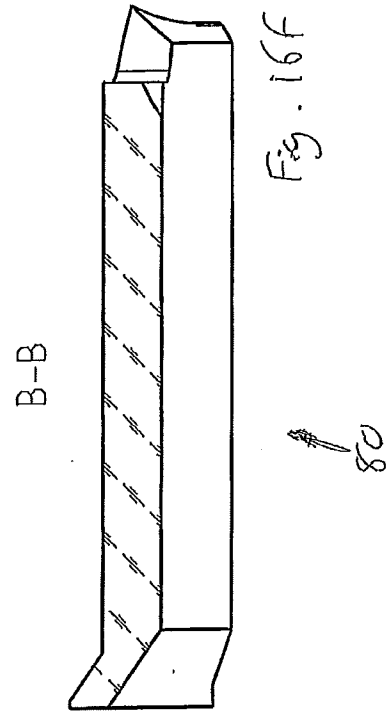
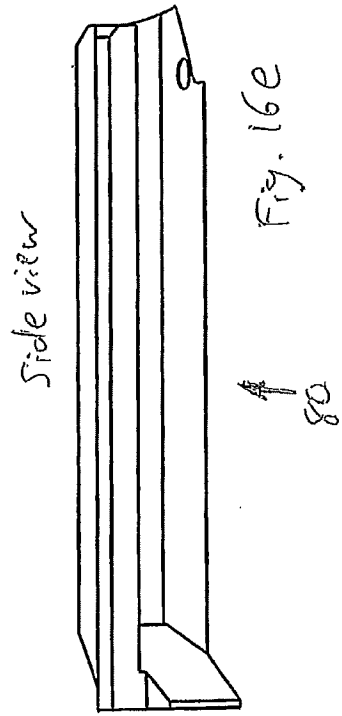

Fig. 16d

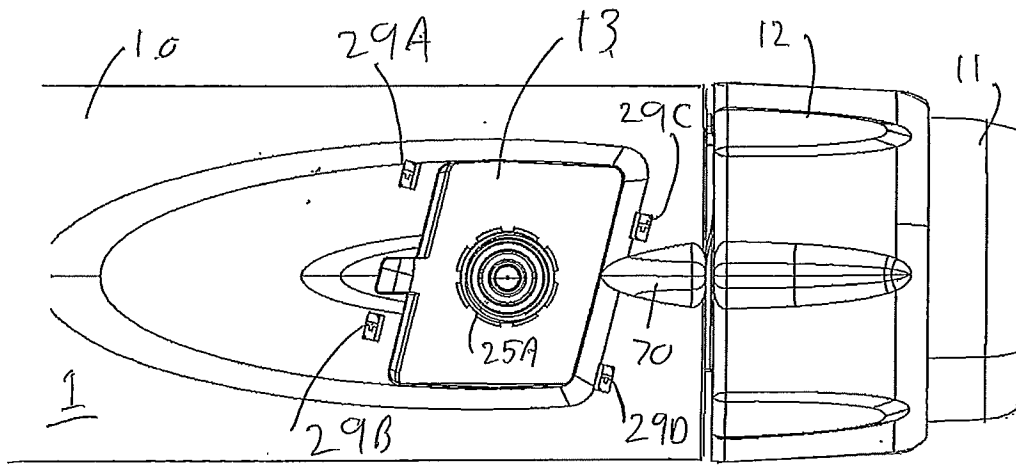

Figure 17

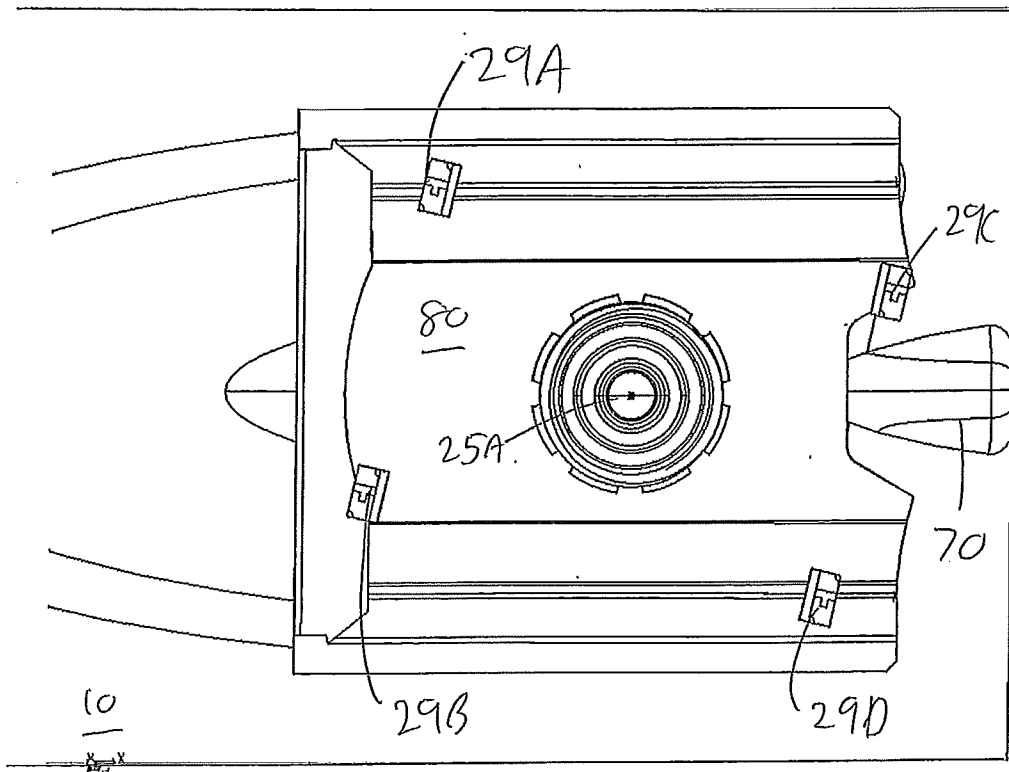

Figure 18

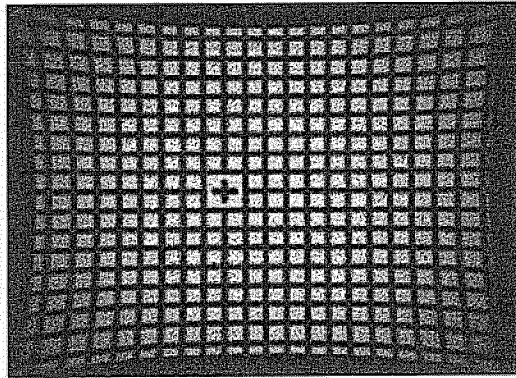

Figure 19a

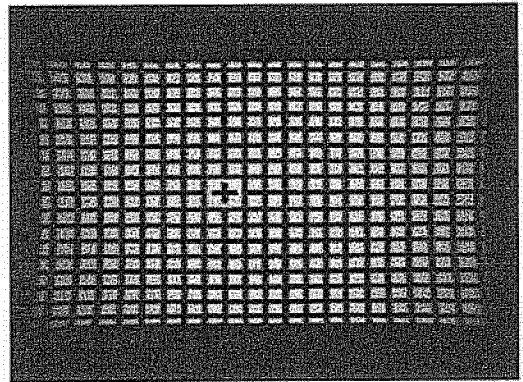

Figure 19b



INTERNATIONAL SEARCH REPORT

International application No  
PCT/EP2013/058322

A. CLASSIFICATION OF SUBJECT MATTER  
INV. A61M5/24 A61M5/315 A61B5/00  
ADD.  
According to International Patent Classification (IPC) or to both national classification and IPC

B. FIELDS SEARCHED  
Minimum documentation searched (classification system followed by classification symbols)  
A61M A61B

Documentation searched other than minimum documentation to the extent that such documents are included in the fields searched

Electronic data base consulted during the international search (name of data base and, where practicable, search terms used)  
EPO-Internal, WPI Data

C. DOCUMENTS CONSIDERED TO BE RELEVANT

Category*	Citation of document, with indication, where appropriate, of the relevant passages	Relevant to claim No.
X	WO 2013/004843 A1 (NOVO NORDISK AS [DK]; NIELSEN OLE CHRISTIAN [DK]; SOERENSEN MORTEN [DK] 10 January 2013 (2013-01-10) page 14, line 24 - page 15, line 33; figures 6,7	1-28
X	WO 2011/117212 A1 (SANOFI AVENTIS DEUTSCHLAND [DE]; SCHABBACH MICHAEL [DE]; KOHLI AMIT [F]) 29 September 2011 (2011-09-29) page 30, lines 12-18; figure 4	1-28
A	US 5 469 294 A (WILT DONALD R [US] ET AL) 21 November 1995 (1995-11-21) column 3, line 58 - column 6, line 25; figures 1-4	1-28
	----- -/--	

Further documents are listed in the continuation of Box C.

See patent family annex.

\* Special categories of cited documents :

"A" document defining the general state of the art which is not considered to be of particular relevance	"T" later document published after the international filing date or priority date and not in conflict with the application but cited to understand the principle or theory underlying the invention
"E" earlier application or patent but published on or after the international filing date	"X" document of particular relevance; the claimed invention cannot be considered novel or cannot be considered to involve an inventive step when the document is taken alone
"L" document which may throw doubts on priority claim(s) or which is cited to establish the publication date of another citation or other special reason (as specified)	"Y" document of particular relevance; the claimed invention cannot be considered to involve an inventive step when the document is combined with one or more other such documents, such combination being obvious to a person skilled in the art
"O" document referring to an oral disclosure, use, exhibition or other means	"&" document member of the same patent family
"P" document published prior to the international filing date but later than the priority date claimed	

Date of the actual completion of the international search  18 February 2014	Date of mailing of the international search report  04/03/2014
---	--

Name and mailing address of the ISA/ European Patent Office, P.B. 5818 Patentlaan 2 NL - 2280 HV Rijswijk Tel. (+31-70) 340-2040, Fax: (+31-70) 340-3016	Authorized officer  Krassow, Heiko
--	--

## INTERNATIONAL SEARCH REPORT

International application No  
PCT/EP2013/058322

C(Continuation). DOCUMENTS CONSIDERED TO BE RELEVANT		
Category*	Citation of document, with indication, where appropriate, of the relevant passages	Relevant to claim No.
A	US 2007/228306 A1 (GANNON COLLEEN P [US] ET AL GANNON COLLEEN PATRICIA [US] ET AL) 4 October 2007 (2007-10-04) figures 2b,3,5a	1-28
E	----- WO 2013/120776 A1 (SANOFI AVENTIS DEUTSCHLAND [DE]) 22 August 2013 (2013-08-22) page 40, line 13 - page 49, line 31; figures 15-19 -----	1-28

# INTERNATIONAL SEARCH REPORT

Information on patent family members

International application No

PCT/EP2013/058322

Patent document cited in search report	Publication date	Patent family member(s)	Publication date
WO 2013004843	A1	10-01-2013	NONE
-----			
WO 2011117212	A1	29-09-2011	AU 2011231697 A1 11-10-2012
			CA 2793274 A1 29-09-2011
			CN 102905613 A 30-01-2013
			EP 2549915 A1 30-01-2013
			JP 2013521963 A 13-06-2013
			KR 20130051929 A 21-05-2013
			SG 184182 A1 30-10-2012
			TW 201204420 A 01-02-2012
			US 2013197445 A1 01-08-2013
			WO 2011117212 A1 29-09-2011
-----			
US 5469294	A	21-11-1995	NONE
-----			
US 2007228306	A1	04-10-2007	NONE
-----			
WO 2013120776	A1	22-08-2013	TW 201345579 A 16-11-2013
			WO 2013120776 A1 22-08-2013
-----			