

(19)
(12)

(KR)
(B1)

(51) 。 Int. Cl.7
H04N 5/76

(45)
(11)
(24)

2004 10 15
10-0453044
2004 10 06

(21) 10-2002-0014849
(22) 2002 03 19

(65)
(43)

10-2003-0075568
2003 09 26

(73) 416

(72) 21-504

(74)

:

(54)

가

가 가

가

가

1

1

2

3 2 replay /

가

TV (Double Screen) (Picture-In-Picture), (Multi Screen) (Picture-Out-Picture)

(Replay)

가

가

가

가

가

가

(Overwrite:)

(a)

; (b) (a)

가 (a)

가

(a) (b)

/

(a)

가

(Overwrite:)

1 (101), (102), () (103), 2 (104), 1 (100), replay() () (105)

2 (Bypass)

(200),

on/off

TS (201),

(Overwrite:)

(202),

on/off (204),

on/off

(203),

(205)

3 2 replay (300), /

(301),

가

on

TS

(302),

off

(303)

1, 1 3
 1 (100) replay (101), (102) (103) replay (101),
 (102) (103) 가 1 (100)
 가 2 (104) replay (101), (102) (103) replay
 TS () (102) (103) TS replay
 (101), 가 가 2 (104) 가 1 replay 1
 가 replay (Path) replay / replay replay (101)
 가 1 replay , replay replay 가 가
 , replay (105) a replay (101) TS (105)
 가 a replay TS (101) TS (103)
) replay (103) replay (101) (103) (103) (103) (Overwrite:
) (103) / (102) replay (101)
 , 1 replay , replay replay (101) replay TS
 (101)가 replay replay (101) (103) r
 replay replay (101) (103) DMA(Direct Memory Access) (103) (105)
 b replay (101) (103) 가 TS (105)가 b (101) (105)
 (103) / 가 TS replay (103) replay (103) (101) ,
 , (105) TS 가 (103) , b
 (103) 가 가 TS (Bypass)
 2 3 (200). 1 1
 . 200 TS replay bypass
 / (201). TS bypass
 / 가 가 , ()
 300). 가 가 가 , (103) TS
 , (103) 가 (301). (103) (103) TS
 , (302). replay replay (101)
 (103) , replay (101) (10
 3) (103) , , 가 (103) (303). 200
 (103) 가 (103) , (103) / 가 (202,
 203). (103) / (103) 가
 / 가 3 TS bypass ()
 300). 가 가 , ,

(103) 가 (301). (103) (103) TS
 (302). replay (103) , replay replay (101) (101)
 (103) (103) , , 가 (10
 3) (103) , , , 가 .
 TS , , ,
 가 (303). (Overwrit
 (103) (204). (103) (Overwrit
 (103) , 가 ,
 / (205). ((3
 300). 가 가 , ((3
 (103) 가 (301). (103) (103) TS
 (302). replay (103) , replay replay (101)
 (103) (103) , , replay (101)
 3) (103) , , , 가 (10
 TS , , ,
 가 (303). 가 ,
 가 .
 가

(57)

1.

, ;

가 ;
가

가

2.

1 , /

3.

1 ,

(Overwrite:)

4.

5.

(a) ;
(b) (a) 가 (a)

가

6.

5 , (a) (b)
/

7.
5 , (a) 가
(Overwrite:)
8.

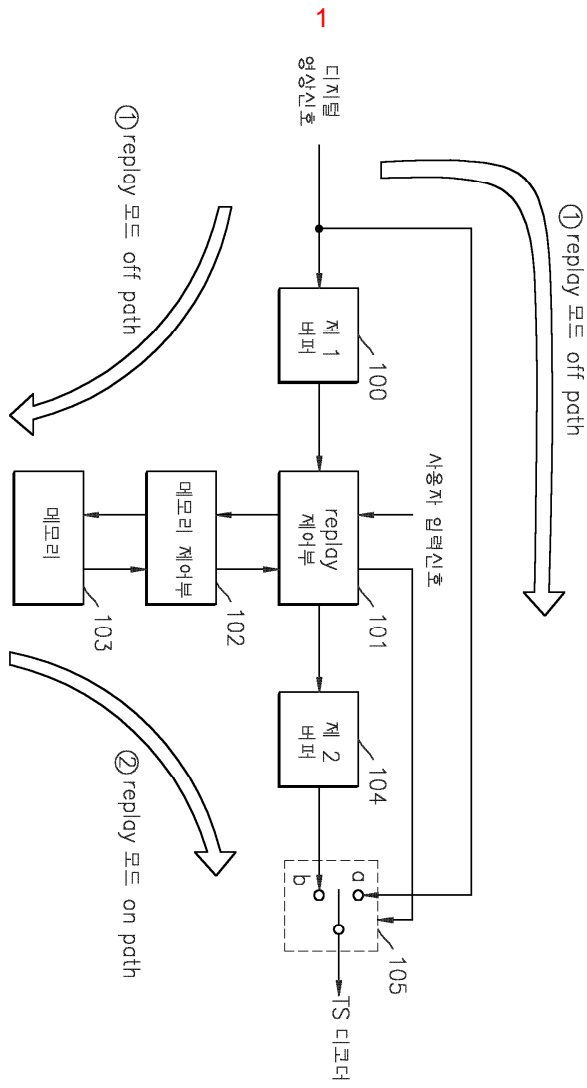

2

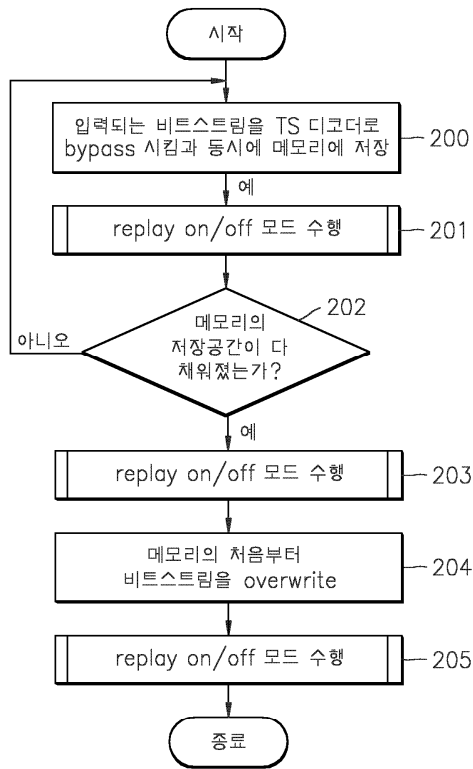

3

