

12 **EUROPEAN PATENT APPLICATION**

21 Application number: 86100891.0

51 Int. Cl.⁴: H 01 R 9/05

22 Date of filing: 23.01.86

30 Priority: 29.01.85 US 696289

71 Applicant: Hewlett-Packard Company
 Mail Stop 20 B-O 3000 Hanover Street
 Palo Alto California 94304(US)

43 Date of publication of application:
 06.08.86 Bulletin 86/32

72 Inventor: Roeder, Bruce Herman
 East 9723 Crossbow Ct.
 Spokane WA. 99206(US)

94 Designated Contracting States:
 DE FR GB

74 Representative: Schulte, Knud, Dipl.-Ing.
 c/o Hewlett-Packard GmbH Europ. Patent- und
 Lizenzabteilung Postfach 1430 Herrenberger Strasse 130
 D-7030 Böblingen(DE)

54 Connector for semi-rigid coaxial cable.

57 An electrical connector for terminating semi-rigid coaxial cable (1) comprises a collet-type, threaded sleeve (13) having an annular base or flange (15) extending radially outward at one end through which a length of semi-rigid coaxial cable is drawn with the cable centre conductor (3) protruding through the flange. The sleeve (13) comprises a plurality of slots (35) extending from the flange length-wise to the rearward end of the sleeve. A standard threaded nut

(31) is tightened on the sleeve (13) against the flange (15). As the nut (31) bottoms out against the flange, the sleeve is compressed against the cable outer conductor (7) providing retention of the cable and electrical contact between the cable outer conductor (7) and the connector. Electrical connection between the center conductor and an electrical circuit can be provided by a socket (19) soldered into a printed circuit board.

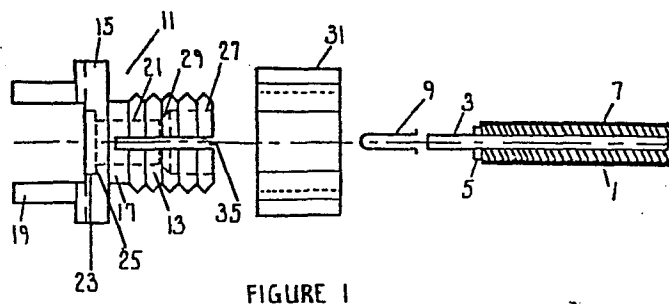

FIGURE 1

DESCRIPTION

CONNECTOR FOR SEMI-RIGID COAXIAL CABLE

The invention relates to a connector for terminating semi-rigid coaxial cable according to the preamble of claim 1. Connectors of that kind are typically used in high performance radio and ultra-high frequency applications for terminating and connecting semi-rigid coaxial cables to a printed circuit board or to a substrate.

Semi-rigid cables typically have a center copper conductor and an outer conductor or shield of plated copper or aluminum and a suitable dielectric medium. In the past, considerable difficulty has been experienced in achieving cable end termination. More particularly, difficulty is experienced in securing the connector to the cable outer conductor with sufficient strength so that the two will not separate under physical loads or fail under thermal cycling which are normal in actual and establishing connectorized contact with the cable outer conductor without degrading electrical performance at the junction. Connectors for semi-rigid coaxial cables are known from US Patent No. 4 408 821 , US Patent No. 3 824 686 and U. S. Patent No. 3 769 444 . These known connectors are expensive to produce, of multi-piece design and employ costly, labor-intensive procedures to achieve effective cable end termination.

Relative to this prior art, it is the object of the invention to provide a connector according to the preamble of claim 1 which has a simpler design.

According to the invention, this object is solved by the characterizing features of claim 1.

According to an underlying concept of the invention, the connector provides retention of the cable and electrical contact with the outer conductor or shield of the cable utilizing a slotted collet-type connector and provides electrical contact to the center conductor by means of a socket which can be soldered into a printed circuit board or which can be double ended and may be soldered to one cable to provide a receiving socket for a matching cable. A standard threaded nut is tightened on the slotted sleeve against a flange to compress the sleeve against the cable outer conductor. No taper is required for the thread of the collet as the angle of the thread form compresses the

collet against the cable as the nut is tightened against either the connector flange or the wall of an enclosure through which the connector may be inserted for shielding purposes. Tightening the nut against the enclosure wall provides electrical connection between the outer
5 cable conductor and the enclosure wall using only one nut. For a floating-type connection, i.e., coupling two coaxial cables together when there is no requirement to ground the outer conductor, tapered thread may be used to compress the collet.

According to claim 2, the connector can be used for connecting a
10 semi-rigid cable to a printed circuit board.

According to claim 3, the connector can be used for grounding the outer conductor of the semi-rigid cable to a bulkhead.

Subsequently, embodiments of the invention are explained with reference to the accompanying drawings.

15 Figure 1 is an exploded side elevation view of a preferred embodiment of the present invention.

Figure 2 is a bottom view of the flange of the connector shown in Figure 1.

Figure 3 is a top view of the connector shown in Figure 1.

20 Figure 4 illustrates the mounting hole pattern required to mount the connector shown in Figure 1 to a printed circuit board.

Figures 5 and 6 are side elevation views of connectors alternately embodying the principles of the present invention.

Referring now to Figures 1, 2, and 3, coaxial cable 1 comprises an axial center conductor 3 enclosed by an insulating dielectric medium 5 and surrounded by an outer shield or conductor 7. A portion of the dielectric 5 and outer conductor 7 is removed exposing a short length of the center conductor 3 which is inserted into the center conductor socket 9. The connector body 11 comprises a slotted
30 collet or sleeve 13 with a flat annular base or flange 15 extending radially outward from the non-slotted end 17 of sleeve 13. Four solder studs 19 attached to the bottom of flange 15 facilitate mounting the connector to a printed circuit board.

The sleeve 13 is formed with an internal bore 21 extending
35 through the flange 15 having a generally snug sliding engagement over the cable outer conductor 7, counterbore 23 and the flange 15 defining shoulder 25 and counterbore 27 defining sloped shoulder 29. The

threaded portion of sleeve 13 utilizes standard thread with no taper. The connector may be machined from brass or some other suitable material or die cast from a suitable material such as zinc and then tin plated if necessary.

5 Assembly of the connector proceeds as follows. A printed circuit board (not shown) is prepared with mounting holes 37 and 39 as shown in Figure 4. Connector 11 is mounted on the printed circuit board with solder studs 19 soldered into mounting holes 37 and center conductor socket 9 soldered into mounting hole 39. The coaxial cable 10 is then inserted into the sleeve 13 such that the cable 1 and center conductor 3 protrude through the flange 15 and the center conductor 3 engages center conductor socket 9. Coupling nut 31 is positioned on the threaded portion of sleeve 13 and tightened against the flange 15. As the coupling nut 31 bottoms out against the flange 15 the sleeve 13 is compressed against the coaxial cable outer conductor 7. Compression of the sleeve 13 forces the inner bore 21 into the softer cable outer conductor 7 insuring retention of the cable in connector 11 and good electrical contact between the connector 11 and the cable outer conductor 7.

20 Figures 5 and 6 illustrate other connector configurations employing the principles of the present invention. Referring now to Figure 5, the connector 40 generally comprises connector body 41 with slotted, threaded collets or sleeves 43 and 45 extending from each end. Internally, the connector defines two concentric bores, the larger bore 47 defines sleeves 43 and 45 and the smaller bore 49 extends through the connector body 41 defining shoulder 51 and 53. The larger bore 47 is of substantially the same diameter as the outer conductors 55 of a pair of coaxial cables to be connected providing a snug fit when the coaxial cables are inserted in the connector sleeves 43 and 45. The outer conductor 55 and dielectric 57 are butted up against shoulder 51 and 53 and center conductors 59 extend into a double ended center conductor socket 61 providing electrical contact between the two center conductors 59. Air gap 63 is formed between the walls of bore 49 and the outer diameter of socket 61 to provide impedance matching.

35 If coupling two coaxial cables together through an enclosure wall, the connector body 41 is inserted through an opening in wall 65,

then threaded coupling nuts (not shown) are tightened on sleeves 43 and 45. As the coupling nuts bottom out against the wall 65 and the connector body 41, the slotted conductor 55 providing support and retention of the cable and electrical contact between the outer conductor 55 and the connector body 41 and the wall 65.

Referring now to Figure 6, a coaxial connector which can be used to ground the outer conductor of a coaxial cable to an enclosure or chassis wall is illustrated. The connector 70 comprises a connector body 71 having a slotted sleeve 73 extending from one end and an internal bore 75 extending through the connector body 71 and sleeve 73. The diameter of the bore 75 is approximately the same as the diameter of the outer conductor 77 of coaxial cable 79 thereby providing a snug fit when cable 79 is drawn through the connector 70. The connector body 71 is inserted through an opening in wall 81 and a coupling nut (not shown) is tightened on sleeve 73. As the coupling nut bottoms out against wall 81, sleeve 73 is compressed against the outer conductor 77 of the cable 79 providing support and retention of the cable 79 and electrical contact between the outer conductor 77 and the connector sleeve 73 thereby grounding the cable outer conductor 77 to the wall 81.

CLAIMS

1. An electrical connector for terminating semi-rigid coaxial cable having a center core conductor and an outer conductive sheath or shield and electrical insulating means therebetween, characterized by

- 5 - an electrically conductive, externally threaded tubular sleeve member (13,15) having a forward end and a rearward end, the sleeve member having an integral annular flange (15) extending radially outward from the forward end of the sleeve member, the flange (15) having a flat side opposite the forward end of the sleeve member, the sleeve member
10 having an internal bore (21) extending the length of the sleeve member through the flange, the sleeve member having a plurality of slots (35) extending from the flange lengthwise to the rearward end of the sleeve member, the internal bore being of substantially the same diameter as the coaxial cable (1) for receiving the coaxial cable, and
15 - an internally threaded nut (31) disposed coaxially on the sleeve, the nut cooperating with the flange for radially inward compression of the sleeve member into gripping engagement with the outer conductive sheath (7) of the coaxial cable when the nut (31) is tightened on the sleeve member into abutment with the flange.

- 20 2. A connector as in claim 1, characterized in that the tubular sleeve member (13, 15) further comprises a plurality of solder studs (19) integrally formed with the flange (15), the plurality of solder studs disposed around the periphery of the flat side of
25 the flange, the plurality of solder studs extending in a forward direction from the flat side of the flange opposite the forward end of the sleeve member and parallel to a longitudinal axis of the sleeve member, the plurality of solder studs for mounting the connector.

- 30 3. A connector as in claim 2, characterized in that the annular flange forms a shoulder with the sleeve member (73) such that when the sleeve member is inserted through a hole in a bulkhead bringing the shoulder into abutment with the bulkhead, the nut to cause radially inward compression of the sleeve member into gripping engagement with the coaxial

cable (79) disposed within the sleeve member and into electrical contact with the outer conductive sheath (77) of that coaxial cable when the nut is tightened on the sleeve member into abutment with the bulkhead thereby grounding the outer conductive sheath of that coaxial cable to the bulkhead.

1/2

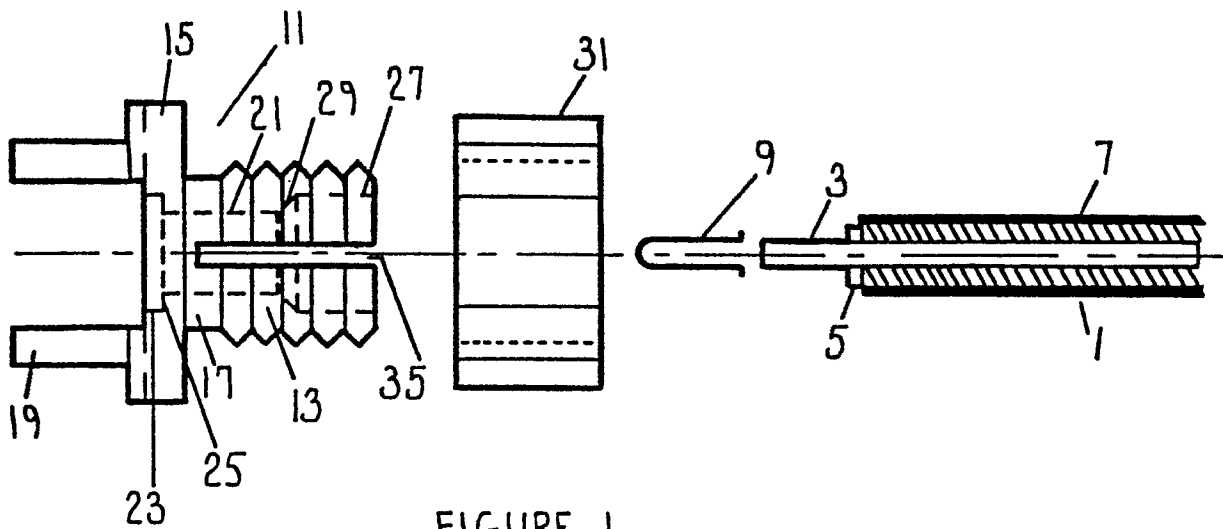

FIGURE 1

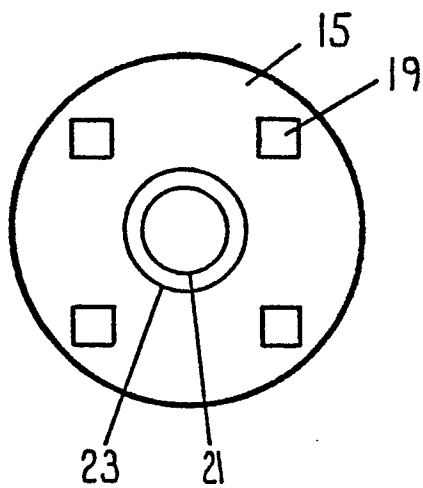

FIGURE 2

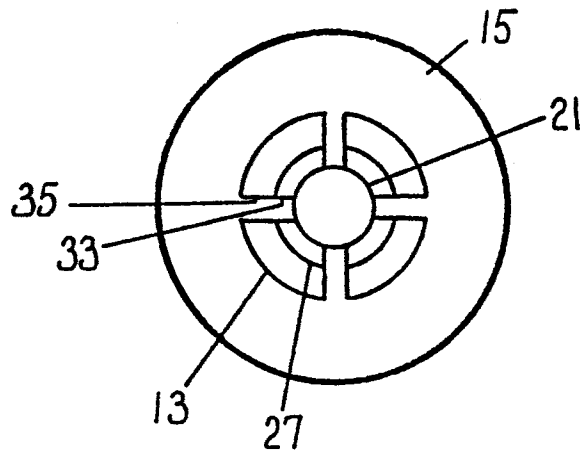

FIGURE 3

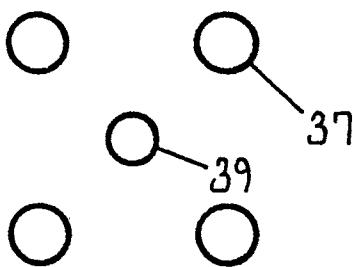

FIGURE 4

2/2

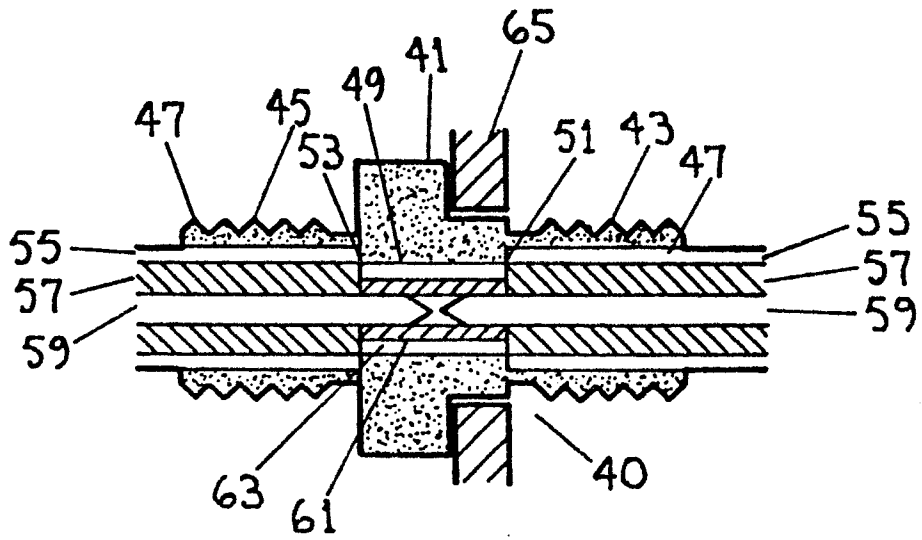

FIGURE 5

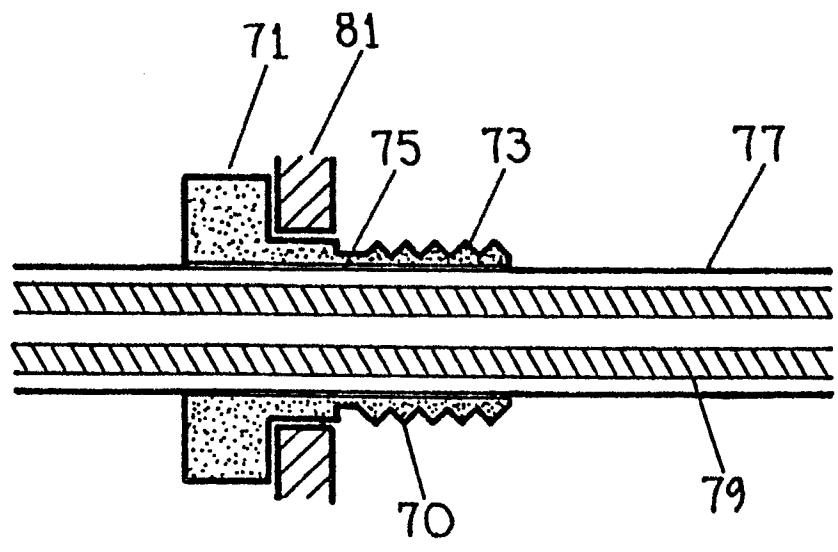

FIGURE 6