



(19) **United States**

(12) **Patent Application Publication**
Nikolov et al.

(10) **Pub. No.: US 2011/0162662 A1**

(43) **Pub. Date: Jul. 7, 2011**

(54) **APPARATUS AND METHOD FOR INSERTION OF CAPSULES INTO FILTER TOWS**

Publication Classification

(75) Inventors: **Bogdan Nikolov**, Plovdiv (BG);
Dimitar Yanchev, Plovdiv (BG)

(51) **Int. Cl.**
A24C 5/47 (2006.01)

(52) **U.S. Cl.** 131/94

(73) Assignee: **AIGER GROUP AG**, Zug (CH)

(57) **ABSTRACT**

(21) Appl. No.: **12/652,522**

An apparatus for insertion of capsules into cigarette filter tows is disclosed. The apparatus may include a tow processing unit, a capsule insertion unit and a filter rod making unit. The capsule insertion unit may include a hopper, a capsule presorter, a belt, an inlet pipe, a capsule insertion wheel, and a tow gathering funnel.

(22) Filed: **Jan. 5, 2010**

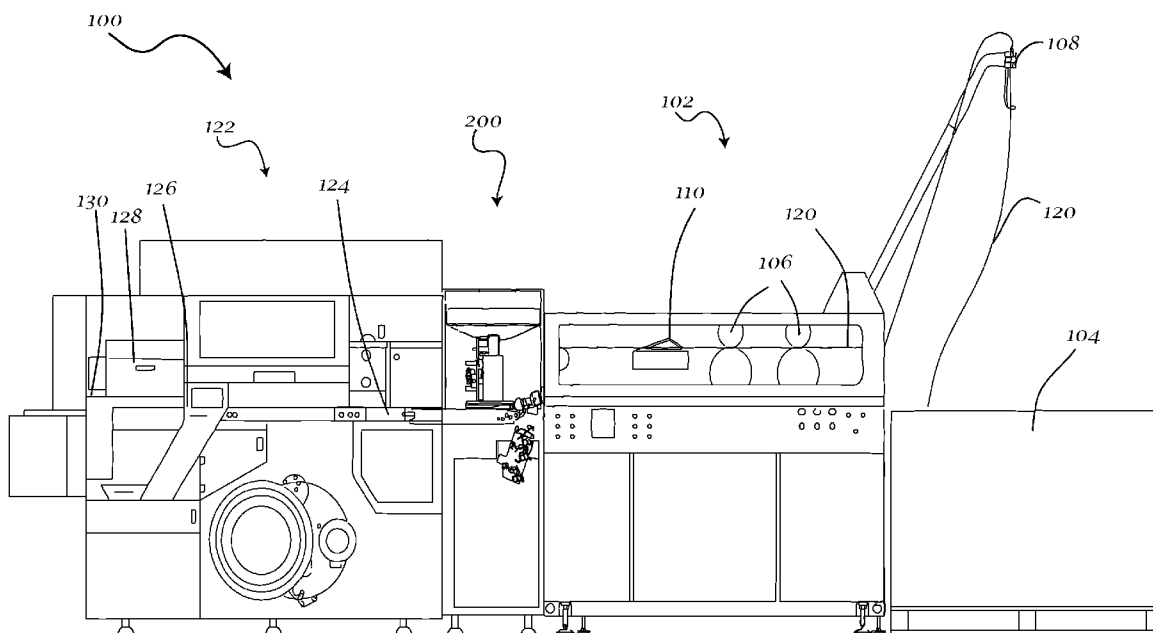

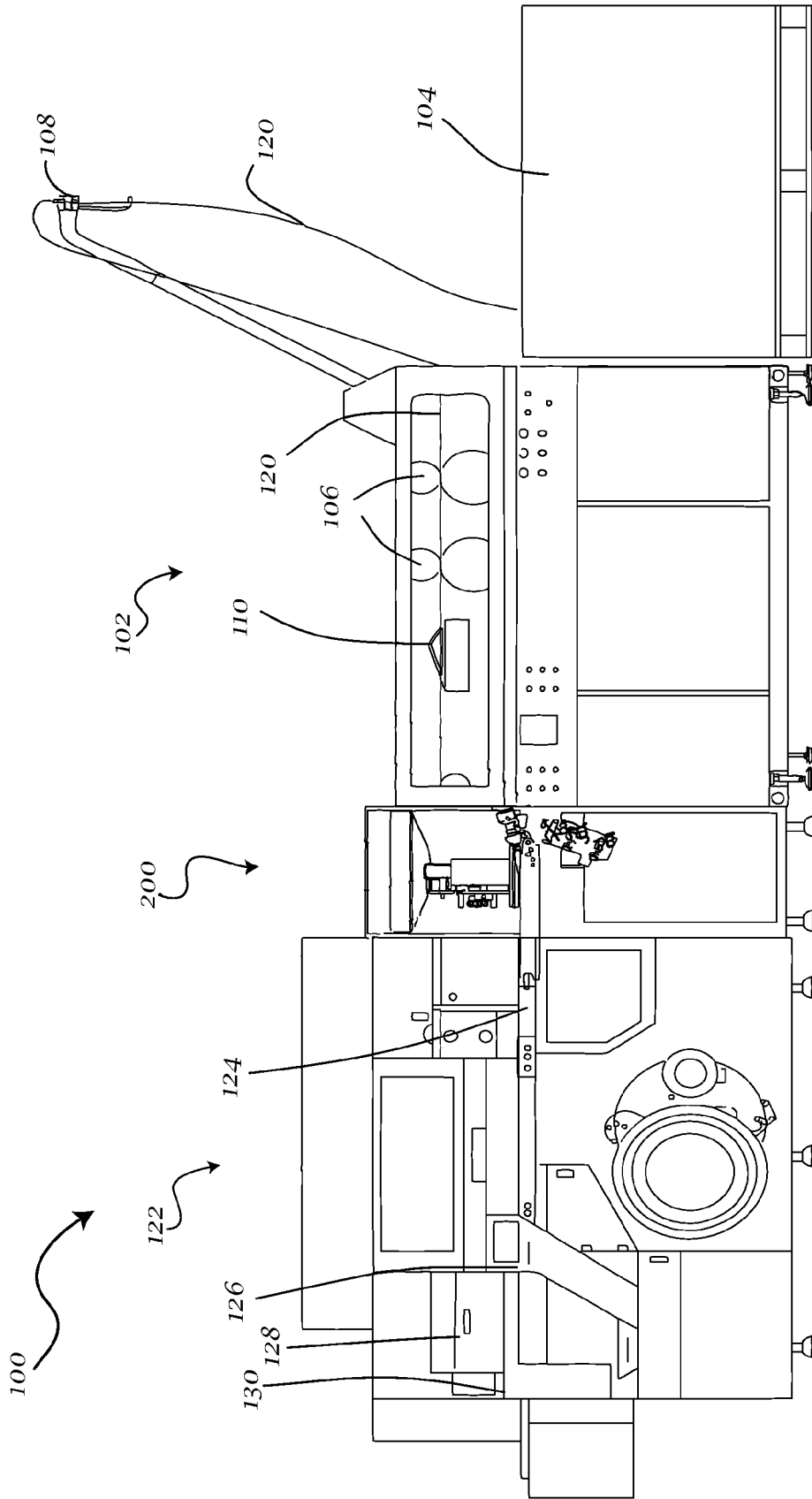

Fig. 1

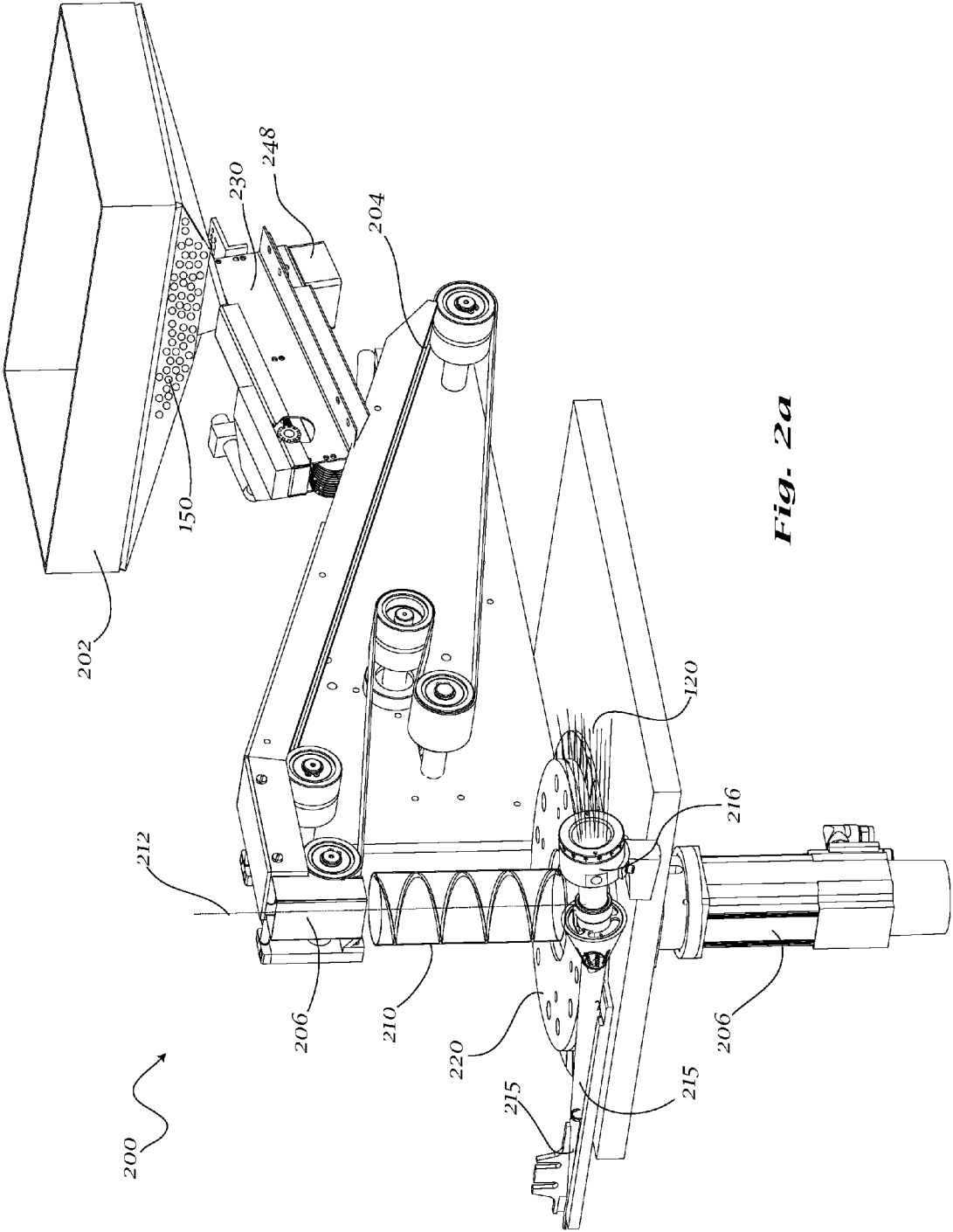

Fig. 2a

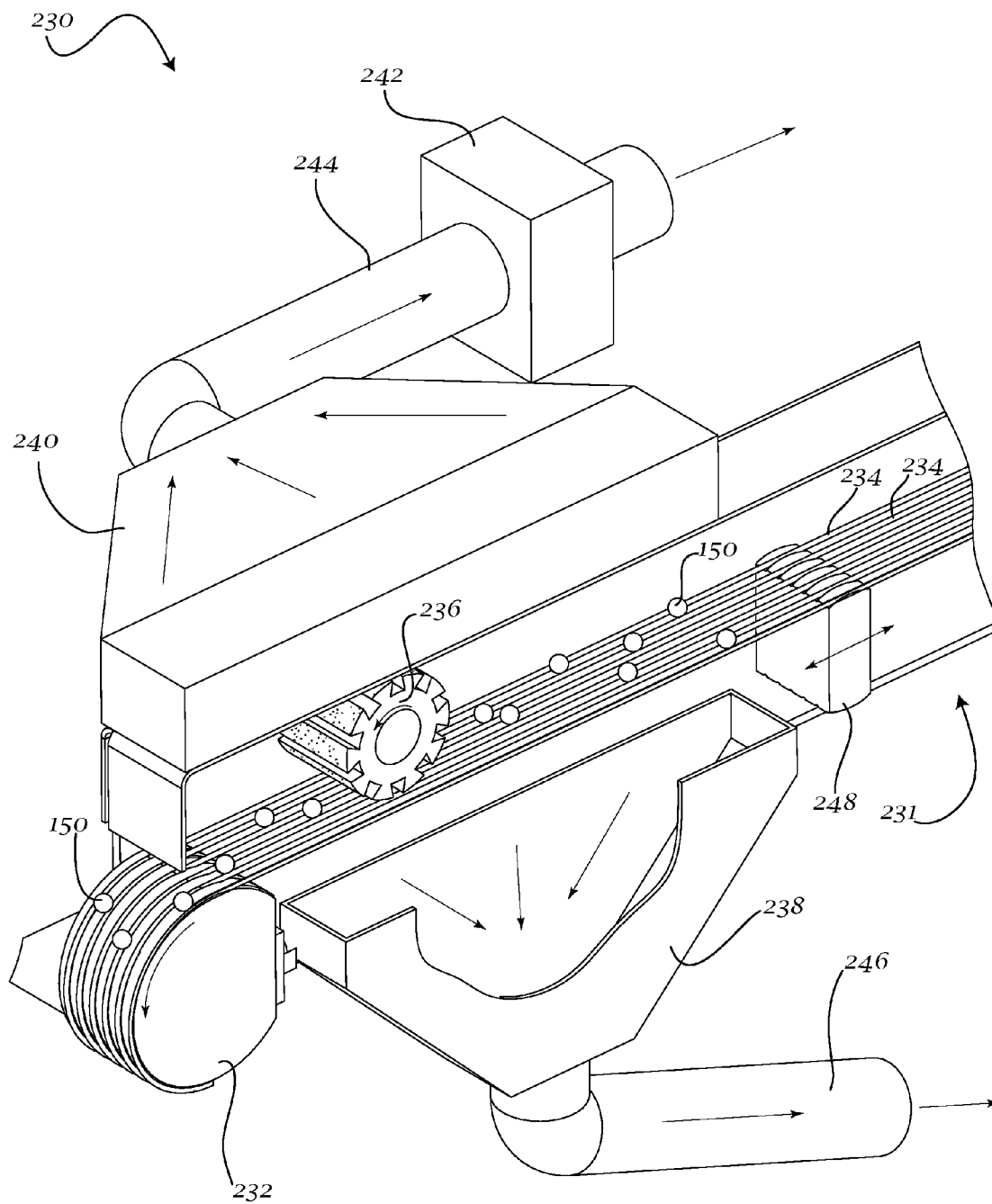
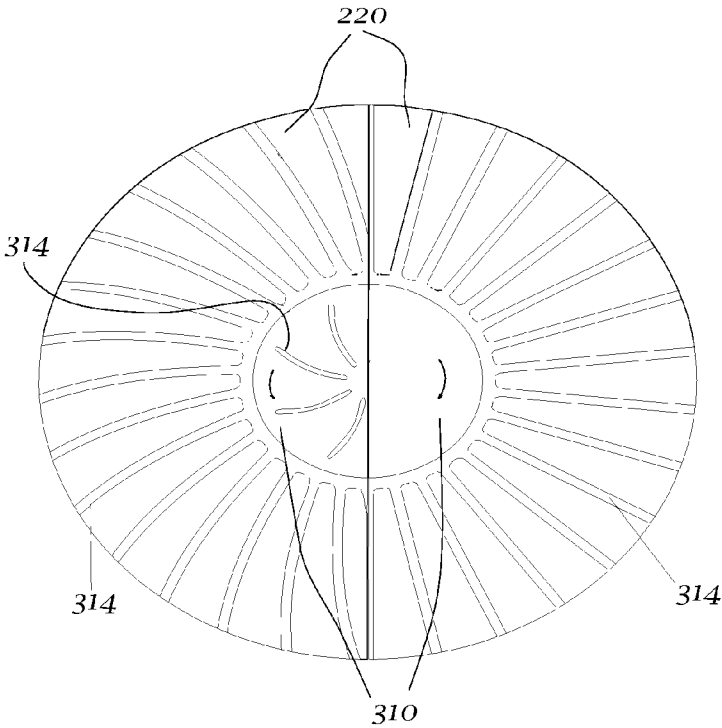
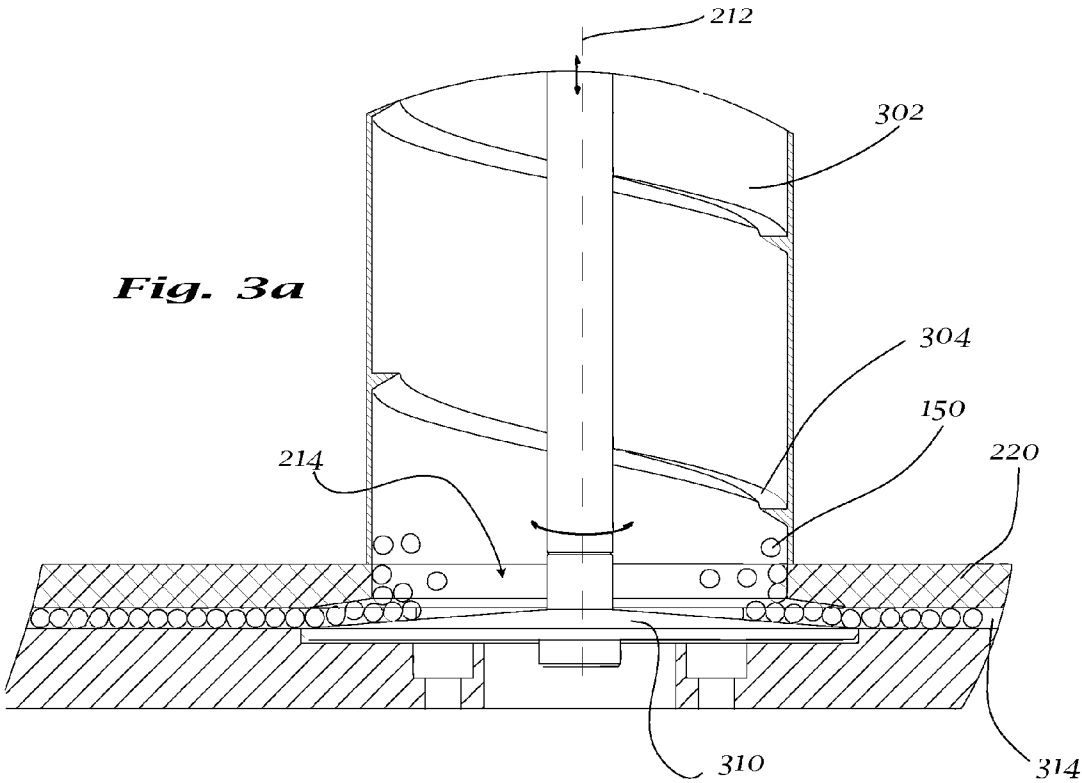

Fig. 2b



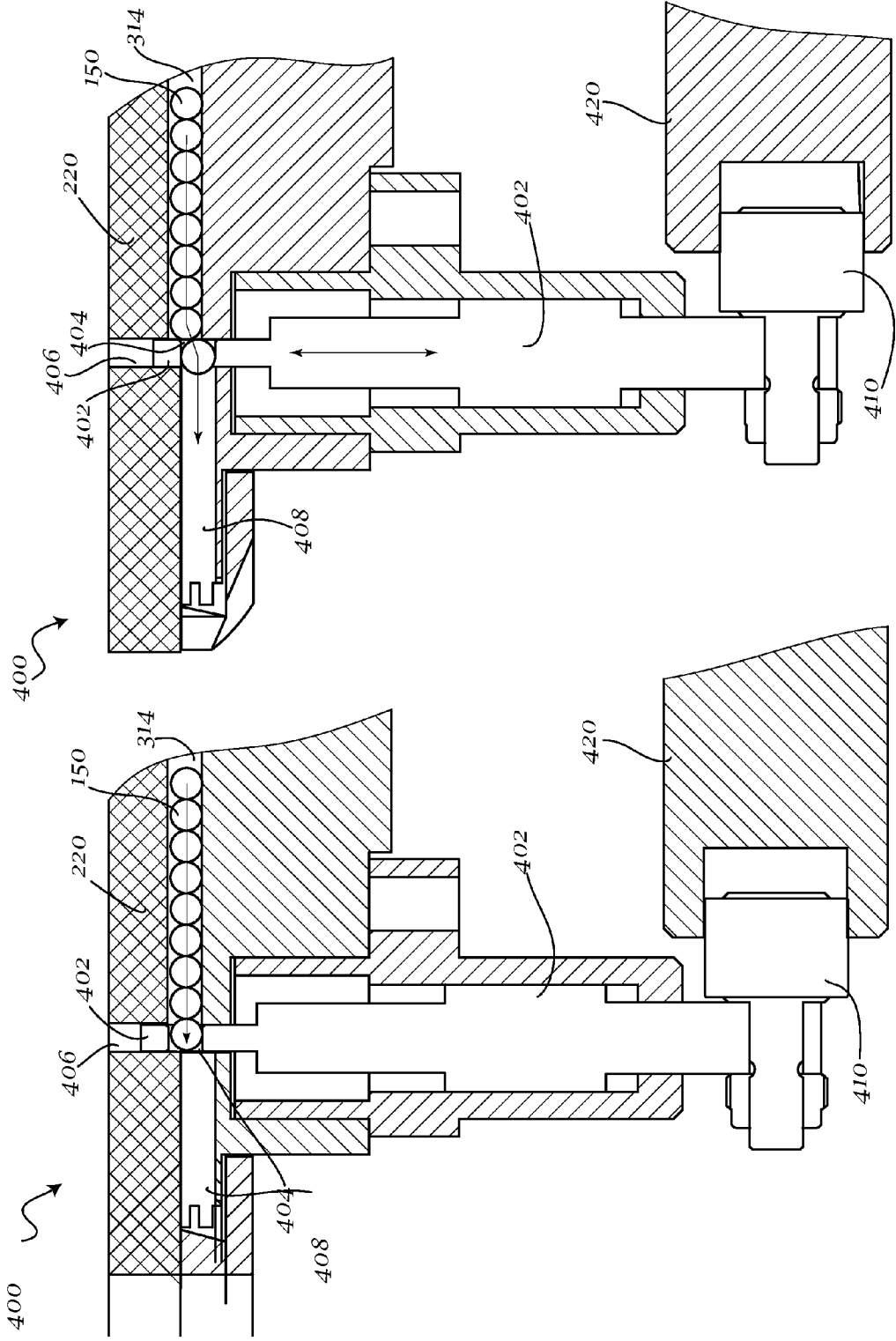

Fig. 4a

Fig. 4b

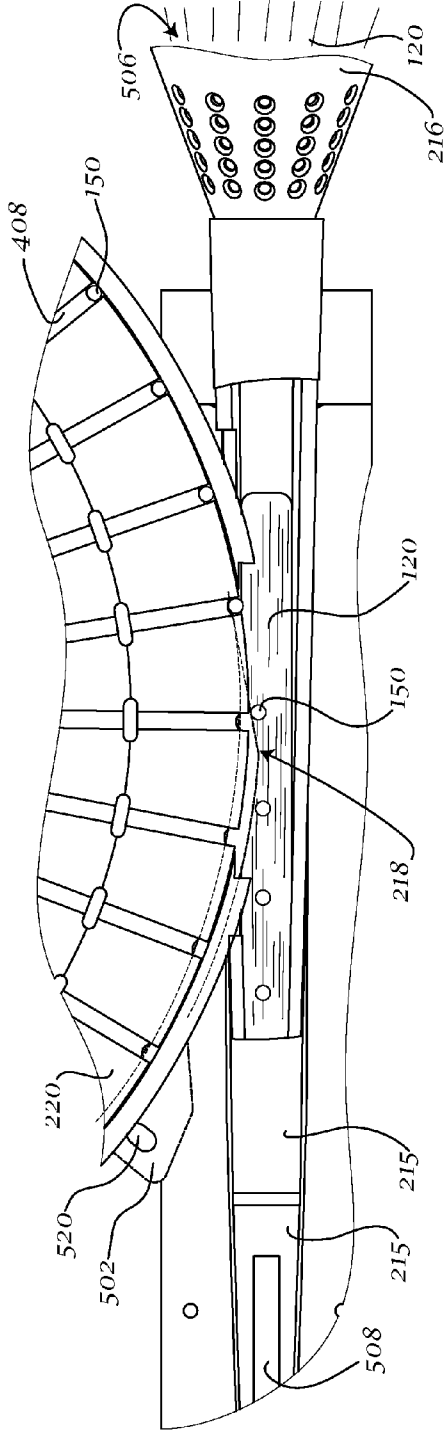

Fig. 5a

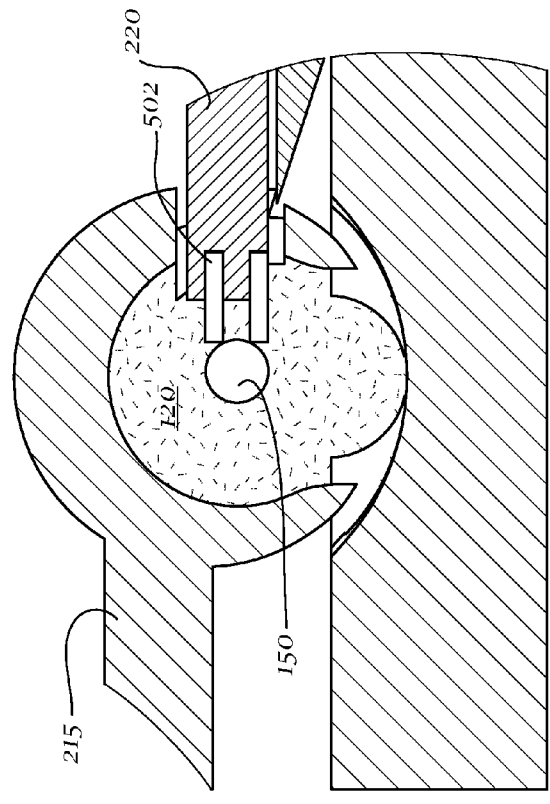

Fig. 5b

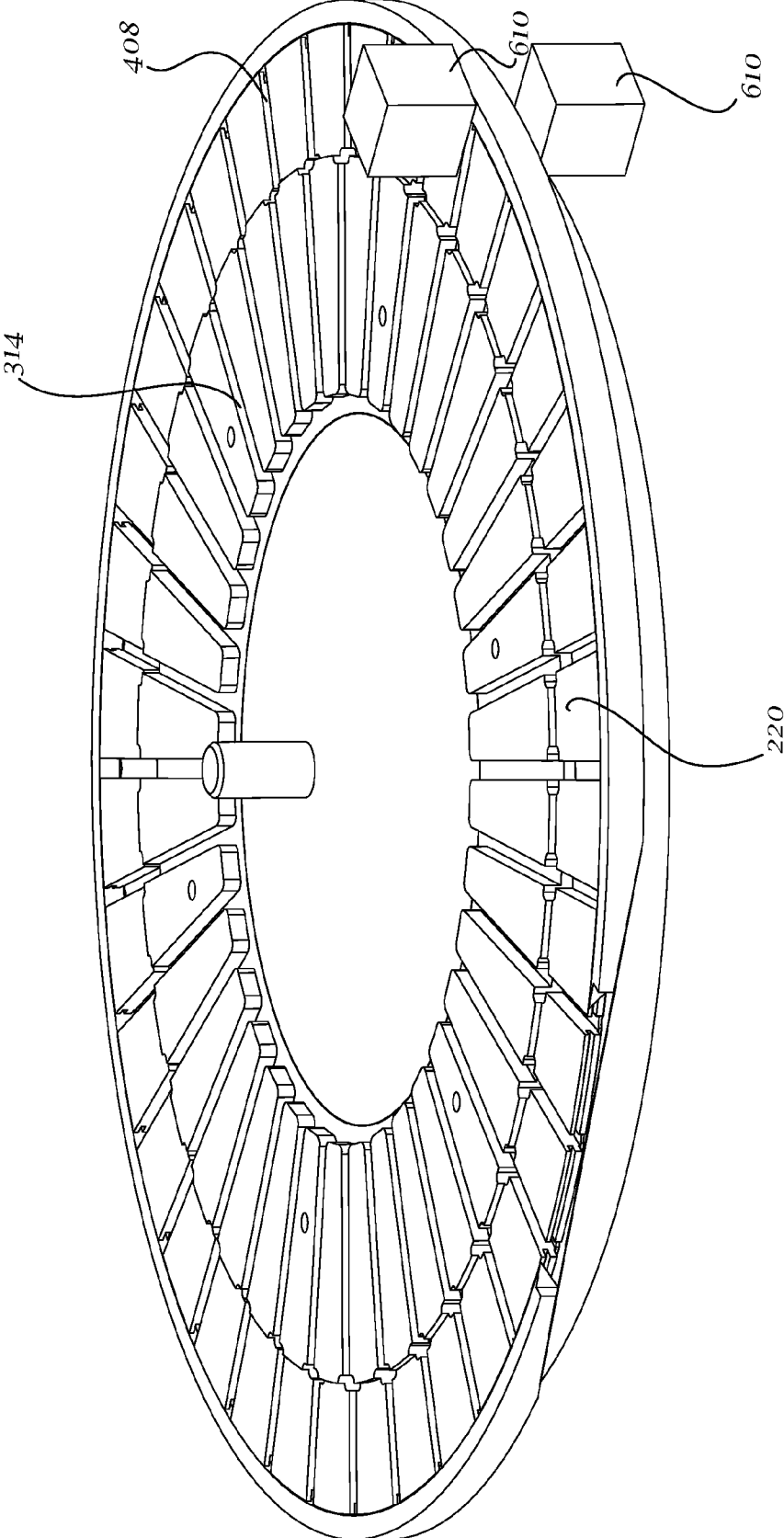

Fig. 6

APPARATUS AND METHOD FOR INSERTION OF CAPSULES INTO FILTER TOWS

BACKGROUND

[0001] Cigarettes and other smoking articles commonly include filter portions (universally known as filter segments) intended to remove some impurities and toxins from the cigarette smoke as it is inhaled. In certain cases, cigarette manufacturers may wish to impart flavor to the cigarette smoke as it is inhaled by the smoker.

[0002] One method of imparting flavor to a cigarette may be to include a flavor capsule within the filter portion of a cigarette. When the capsule is ruptured, it releases flavorings or aromatic material into the air stream passing through the filter. These capsules may also alter other chemical or physical characteristics of the inhaled smoke, such as, for example, cooling or moistening the smoke such that the smoker is provided with an enhanced smoking experience.

SUMMARY

[0003] An apparatus for insertion of capsules into cigarette filter tows, including a tow processing unit coupled to a capsule insertion unit and a filter rod making unit coupled to the capsule insertion unit, the tow processing unit including a tow bale, a plurality of rollers, a plurality of banding jets and a plasticizer chamber, and the rod making unit including a garniture bed, a sensor and a knife carrier. The capsule insertion unit including a hopper, an in-line presorting device, an endless belt disposed between the hopper and an inlet pipe, an insertion wheel rotating about an axis of rotation, the insertion wheel including a circular cavity in communication with said inlet pipe, an in-line sensor continuously controlling the quality of the capsules and a tow gathering funnel configured to receive an edge of the insertion wheel.

[0004] The insertion wheel includes a plurality of radial channels in communication with the circular cavity of the wheel, each radial channel configured to receive a plurality of capsules; a plurality of insertion channels, each insertion channel in communication with a corresponding radial channel and terminating at the outer edge of the insertion wheel; and a plurality of separation mechanisms, each separation mechanism disposed between a corresponding radial channel and a corresponding insertion channel.

BRIEF DESCRIPTION OF THE DRAWINGS

[0005] FIG. 1 is an exemplary diagram of an apparatus for insertion of capsules into filter tows.

[0006] FIG. 2a is a view of an exemplary embodiment of a capsule insertion unit.

[0007] FIG. 2b is a view of an exemplary embodiment of a capsule presorting device.

[0008] FIG. 3a is a cross-section of an exemplary embodiment of a capsule insertion unit.

[0009] FIG. 3b is a diagram of an exemplary embodiment of an insertion wheel and a distribution disk of a capsule insertion unit.

[0010] FIG. 4a is a cross-section detail of an exemplary embodiment of a separation mechanism in an upper position.

[0011] FIG. 4b is a cross-section detail of an exemplary embodiment of a separation mechanism in a lower position.

[0012] FIG. 5a is a view of an exemplary embodiment of an insertion wheel of a capsule insertion unit operatively

engaged with an exemplary embodiment of a tow gathering funnel of a capsule insertion unit.

[0013] FIG. 5b is a cross-sectional view of an exemplary embodiment of a capsule positioning guide.

[0014] FIG. 6 is a view of an exemplary embodiment of a capsule quality sensor.

DETAILED DESCRIPTION

[0015] Aspects of the invention are disclosed in the following description and related drawings directed to specific embodiments of the invention. Alternate embodiments may be devised without departing from the spirit or the scope of the invention. Additionally, well-known elements of exemplary embodiments of the invention will not be described in detail or will be omitted so as not to obscure the relevant details of the invention. Further, to facilitate an understanding of the description discussion of several terms used herein follows.

[0016] As used herein, the word “exemplary” means “serving as an example, instance or illustration.” The embodiments described herein are not limiting, but rather are exemplary only. It should be understood that the described embodiment are not necessarily to be construed as preferred or advantageous over other embodiments. Moreover, the terms “embodiments of the invention”, “embodiments” or “invention” do not require that all embodiments of the invention include the discussed feature, advantage or mode of operation.

[0017] Turning to FIG. 1, an apparatus for inserting capsules into filter webs 100 is provided. Apparatus 100 may include a tow processor unit 102, a capsule insertion unit 200 and a rod making unit 122. Tow processor unit 102 may include a bale 104, a plurality of rollers 106, a plurality of banding jets 108 and plasticizer chamber 110. Rod making unit 122 may include a garniture bed 124, sensor 126, knife carrier 128 and ejector 130. Filter tow 120 may be withdrawn from bale 104, and directed towards rollers 106 and banding jets 108, which facilitate the expansion and blooming of tow 120 to a desired width. After passing over rollers 106 and banding jets 108, tow 120 may be directed to plasticizer chamber 110, where it may be coated with plasticizer, thereby facilitating swelling of the fibers of tow 120 and imparting greater cohesive properties to tow 120. Upon exiting plasticizer chamber 110, tow 120 may be directed towards capsule insertion unit 200.

[0018] Turning now to FIG. 2a, capsule insertion unit 200 may include a hopper 202, presorting device 230, endless belt 204, feeding device 206, motor 208, inlet pipe 210, and insertion wheel 220. Capsule insertion unit 200 may also include tow gathering funnel 216 and tongue members 214. Motor 208 may be a servomotor or any other motive device known to one having ordinary skill in the art. Hopper 202 may have an opening defined near the bottom thereof. Presorting device 230 may be positioned between hopper 202 and endless belt 204. Endless belt 204 may be positioned in close proximity to presorting device 230 and have an end positioned substantially near feeding device 206 such that capsules 150 may be collected in hopper 202 and transferred to feeding device 206 through presorting device 230 and endless belt 204. Feeding device 206 may be positioned above inlet pipe 210 and inlet pipe 210 may be positioned above insertion wheel 220. Insertion wheel 220 may rotate around an axis of rotation 212 and may be disposed such that axis of rotation 212 is substantially vertical. Insertion wheel 220 may have a circular cavity 214

defined therein such that cavity 214 is concentric with insertion wheel 220. Feeding device 206 and inlet pipe 210 may be positioned such that they are substantially coaxial with axis of rotation 212 and such that feeding device 206 is in communication with inlet pipe 210 and inlet pipe 210 is in communication with circular cavity 214.

[0019] Turning to FIG. 2b, an exemplary embodiment of a capsule presorting device 230 is provided. Presorting device 230 may include a vibrating thread transporter 231, a roller 232, a plurality of transport threads 234, a rotating brush 236, at least two aspiration devices 238, 240, a control device 242, at least two extraction pipes 244, 246, and a vibrating device 248. Transport threads 234 may be positioned such that gaps between any two of the plurality of transport threads 234 are created. The gap between transport threads 234 may be sized to facilitate transporting capsules 150 that meet the desired capsule size standards through presorting device 230 while facilitating the removal of smaller or irregularly-shaped capsules. Vibrating device 248 may facilitate the movement of capsules 150 through presorting device 230 while further facilitating the removal of smaller or irregularly-sized capsules by imparting vibrational motion to threads 234. Smaller or irregularly-sized capsules may therefore fall through the gaps between threads 234 into bottom aspirating device 238, and removed via bottom extraction pipe 246. Rotating brush 236 may be positioned such that the axis of rotation of rotating brush 236 is substantially perpendicular to threads 234 and may rotate in the opposite direction of the motion of capsules 150. Brush 236 may facilitate removing dust from capsules 150 that may have accumulated during the manufacturing process and may also facilitate the removal of capsules having a lower capsule mass than desired. Capsules with mass that is lower than the desired mass may not pass under the brush and are consequently sucked into upper aspiration device 240 and removed via top extraction pipe 244. Control device 242 may adjust the amount of negative air pressure through top aspiration device 236, thereby allowing the user to control the upper limit of the mass of the capsules that are removed via top aspiration device 236. Consequently, capsules 150 that meet the desired size, shape and mass standards may pass towards roller 232, where they may exit presorting device 230 and may fall or be placed onto endless belt 204.

[0020] Turning to FIGS. 3a-3b, inlet pipe 210 may be substantially cylindrical and include a cavity 302 defined by the inner surface of inlet pipe 210. Inlet pipe 210 may also have a spiral ramp 304 disposed within cavity 302. Spiral ramp 304 may be adjacent to the inner surface of inlet pipe 210 and may have a substantially downward slope. Spiral ramp 304 may be configured to direct capsules 150 from the top of tube 210 to the bottom of tube 210.

[0021] Disposed substantially horizontally within circular cavity 214 of, and concentric to insertion wheel 220 may be distribution disk 310. Distribution disk 310 may include an axle 216. Axle 216 may be positioned substantially coaxial to axis of rotation 212 and may include a spring 218 disposed therein. Capsules 150 exiting from inlet pipe 210 may collect within circular cavity 214 and on the top surface of distribution disk 310. The elevation of distribution disk 310 within circular cavity 214 may be automatically adjusted depending on the quantity of capsules 150 present on the top surface of distribution disk 310 to facilitate smooth transfer of capsules from distribution disk 310 to insertion wheel 220. Distribution disk 310 may oscillate around axis of rotation 212, and may have an oscillation range of approximately $\pm 180^\circ$. The

top surface of distribution disk 310 may be flat or may have grooves 312 defined therein. The oscillating action and grooves 312 of distribution disk 310 may likewise facilitate supplying capsules 150 to insertion wheel 220.

[0022] The oscillation of distribution disk 310 may be facilitated by spring 218. The rotation of insertion wheel 220 around axis of rotation 212 may impart rotational motion to distribution disk 310 via frictional contact between insertion wheel 220 and distribution disk 310. As distribution disk 310 begins to rotate with insertion wheel 220, spring 218 may be imparted with increasing tension. As spring 218 reaches its limit of tension, it may decompress, thereby returning distribution disk 310 to its original position. The repetition of this motion may thus cause distribution disk to oscillate, thereby facilitating the movement of capsules 150 towards the edges of distribution disk 310 and into insertion wheel 220.

[0023] Insertion wheel 220 may include radial channels 314 defined in the interior thereof. Radial channels 314 may extend from circular cavity 214 towards the periphery of insertion wheel 220. Radial channels 314 may have a linear or arcuate profile; the particular profile may be chosen depending on the shape of capsules 150 used in a particular application and the speed with which capsules 150 pass through radial channels 314. Capsules 150 may pass from distribution disk 310 into radial channels 314 of insertion wheel 220. The rotation of insertion wheel 220 around axis of rotation 212 provides centrifugal force to facilitate maintenance of capsules 150 within radial channels 314 as well as the movement of capsules 150 from circular cavity 214 to the outer edge of insertion wheel 220 via radial channels 314.

[0024] Turning to FIGS. 4a-4b, insertion wheel 220 may include a plurality of separation mechanisms 400 proximate to the outer edge of insertion wheel 220. Each radial channel 314 may have a corresponding separation mechanism 400 and a corresponding insertion channel 408. Each separation channel 408 may terminate in an aperture disposed on the outer edge of insertion wheel 220. Separation mechanism 400 may facilitate separating a single capsule 150 from the sequence of capsules 150 disposed within a radial channel 314. Separation mechanism 400 may include a sliding member 402 having a cavity 404, and disposed within a vertical channel 406. Separation mechanism 400 may also include a bearing assembly 410 and a closed cam 420. Cavity 404 may be configured to receive a single capsule 150 from a radial channel 314. When sliding member 402 is in a raised position, a capsule 150 may pass from radial channel 314 into cavity 404. When a capsule 150 is fully disposed within cavity 404, further outward movement of capsule 150 is prevented by the upper edge of insertion channel 408. At a predetermined point along the rotation of insertion wheel 220, sliding member 402 may be moved to a lower position within vertical channel 406. When sliding member 402 is in the lower position, capsule 150 may pass from cavity 404 into insertion channel 408 due to the centrifugal force generated by the rotation of insertion wheel 220. Simultaneously, capsules 150 that are located within radial channel 314 are generally inhibited from passing into cavity 404 by sliding member 402 when sliding member 402 is in the lower position. The movement of sliding member 402 may be facilitated by closed cam 420. Cam 420 may include a groove 422. Groove 422 may receive bearing assembly 410 therein and may have an undulating profile. As bearing assembly 410 slides through groove 422 of cam 420, it may impart precise vertical movement to sliding member 402. The shape of the profile of groove 422 may therefore

facilitate precise control of the point at which the capsules are separated and inserted in tow 120.

[0025] Turning to FIGS. 5a-5b, the edge of insertion wheel 220 may be received in slit 218 of tow gathering funnel 216. Tow gathering funnel 216 may include tongues 214, at least two static guides 502, inlet aperture 506 and outlet aperture 508. Tow 120 may be drawn into tow gathering funnel 216 via inlet aperture 506. Within tow gathering funnel 216, tow 120 may be compacted by tongues 214 such that tow 120 exits through outlet aperture 508 having a substantially rod-like shape. As tow 120 passes through tow gathering funnel 216, capsules 150 pass from insertion channels 408 of insertion wheel 220 into tow gathering funnel 216. The transfer of capsules from insertion channels 408 into filter tow 120 is facilitated by the centrifugal force generated by the rotation of insertion wheel 220. Guides 502 may facilitate the transfer of a capsule 150 from the insertion wheel 220 into the tow 120. As shown in FIG. 5b, guides 502 may also facilitate the precise support and positioning of capsules in tow 120. As capsules enter tow 120, guides 502 may facilitate precisely positioning capsules 150 at the desired position within tow 120. Guides 502 may also include an opening 520. Opening 520 may allow the user to precisely set the horizontal and vertical position of guides 502.

[0026] The motion of tow 120 and the rotation of insertion wheel 220 may be synchronized such that the linear speed of tow 120 may be substantially equal to the tangential speed of insertion wheel 220. Such synchronization facilitates the insertion of capsules 150 into tow 120 at equal intervals, thereby allowing capsules 150 to be equally spaced relative to each other. The tow may be simultaneously shaped into a substantially rod-like configuration by tongues 214. Consequently, when tow 120 exits through tow outlet aperture 508, capsules 150 are embedded at the desired regular intervals within tow 120.

[0027] Turning to FIG. 6, insertion wheel 220 may also include at least one sensor 610. Sensor 610 may measure the quality of the capsules disposed within insertion wheel 220 prior to insertion. At least one sensor 610 may include an optical sensor, a laser sensor, a microwave sensor, an induction sensor, a capacitive sensor, or any other sensor known to one having ordinary skill in the art. At least one sensor 610 may also include a video camera. Capsules that do not meet desired quality standards may then be ejected from insertion wheel 220.

[0028] In operation, capsules 150 may be stored in hopper 202 and be withdrawn there from by presorting device 230, as shown in FIGS. 2a-2b. Capsules 150 may have a diameter between approximately 0.5 mm and approximately 8 mm, and may have a spherical, elliptical, irregular, or any other desired shape. Capsules 150 may also be filled with a liquid or any other desired substance. Presorting device 230 may remove dust from capsules 150 and may also remove any capsule fragments, empty capsules, irregularly shaped capsules and any other capsules that do not meet desired quality standards. Upon exiting presorting device 230, capsules 150 may be deposited on belt 204. Belt 204 may transfer capsules 150 from presorting device 230 to inlet pipe 206. Capsules 150 may then be deposited via spiral ramp 304 disposed within cavity 302 of inlet pipe 206 into circular cavity 214 of insertion wheel 220, as shown in FIG. 3a. Capsules 150 may thus be deposited onto the top surface of distribution disk 310, which is disposed within circular cavity 214. As distribution disk 310 oscillates around axis of rotation 212, capsules 150

are driven from distribution disk 310 into radial channels 314 of insertion wheel 220. Insertion wheel 220 may be driven by motor 208 and rotate around axis of rotation 212. As insertion wheel 220 rotates, capsules 150 may be driven through radial channels 314 by the centrifugal force generated from the rotation of insertion wheel 220. During the rotation of the insertion disk 220, the capsules 150 pass through sensor 610, which may determine the quality of capsules 150 and may eject any capsules not meeting desired quality standards. While a particular radial channel 314 is not in proximity to tow gathering funnel 216, sliding member 402 of a corresponding separation mechanism 400 may be located in a raised position, reducing the likelihood of capsules 150 passing from radial channel 314 into insertion channel 408. As a particular radial channel 314 approaches tow gathering funnel 216, sliding member 402 of a corresponding separation mechanism 400 may move into a lowered position, thereby allowing a capsule 150 to pass via cavity 404 from radial channel 314 into insertion channel 408, as shown in FIG. 4a and FIG. 4b. As a radial channel 314 departs from tow gathering funnel 216, sliding member 402 of a corresponding separation mechanism 400 may return to a raised position, thereby reducing the likelihood of remaining capsules 150 passing from radial channel 314 into insertion channel 408.

[0029] A capsule 150 may then be carried by insertion wheel 220 towards tow gathering funnel 216. As a particular insertion channel 408 approaches slit 218 of tow gathering funnel 216, a capsule 150 may pass from insertion channel 408 into tow 120, as shown in FIG. 5. Guides 502 may then adjust the position of capsule 150 within tow 120 so that capsule 150 is placed in the desired position within tow 120. As tow 120 exits tow gathering funnel 216, tongues 214 facilitate the formation of tow 120 into a substantially rod-like configuration.

[0030] Turning back to FIG. 1, filter tow 120 with capsules 150 disposed at regular intervals therein may then exit capsule insertion unit 200 and be directed to rod making unit 122. Tow 120 may then be deposited on garniture bed 124 wherein it may be formed into a continuous filter rod. The continuous filter rod may then be directed towards sensor 126 and knife carrier 128, where the continuous filter rod may be cut into individual filter portions by knives (not shown) within knife carrier 128. The individual filter portions may be evaluated by sensor 126 and filter portions that do not conform to desired specifications may be discarded via ejector 130.

[0031] The foregoing description and accompanying figures illustrate the principles, preferred embodiments and modes of operation of the invention. However, the invention should not be construed as being limited to the particular embodiments discussed above. Additional variations of the embodiments discussed above will be appreciated by those skilled in the art.

[0032] Therefore, the above-described embodiments should be regarded as illustrative rather than restrictive. Accordingly, it should be appreciated that variations to those embodiments can be made by those skilled in the art without departing from the scope of the invention as defined by the following claims.

What is claimed is:

1. An apparatus for insertion of capsules into cigarette filter tows, comprising:
 - a tow processing unit coupled to a capsule insertion unit and a filter rod making unit coupled to the capsule insertion unit,

the tow processing unit further comprising a tow bale, a plurality of rollers, a plurality of banding jets and a plasticizer chamber;

the capsule insertion unit further comprising a hopper, a presorting unit, an endless belt disposed between said presorting unit and an inlet pipe, an insertion wheel rotating about an axis of rotation, said insertion wheel further comprising a circular cavity in communication with said inlet pipe and a distribution disk disposed within said cavity, and a tow gathering funnel configured to receive an edge of said insertion wheel; and

the rod making unit further comprising a garniture bed, a sensor, a knife carrier and an ejector.

2. The apparatus of claim 1, wherein the insertion wheel further comprises:

- at least one capsule quality sensor;
- a plurality of radial channels in communication with said circular cavity, each of said radial grooves configured to receive a plurality of capsules;
- a plurality of insertion channels, each of said insertion channels being in communication with a corresponding radial channel and terminating at the outer edge of the insertion wheel; and
- a plurality of separation mechanisms, each of said plurality of separation mechanisms disposed between a corresponding radial channel and a corresponding insertion channel.

3. The apparatus of claim 1, wherein each of said plurality of separation mechanisms further comprises:

- a vertical channel in communication with a corresponding radial channel and a corresponding insertion channel;
- a sliding member slidably disposed within said vertical channel, the sliding member comprising a cavity configured to receive a single capsule; and
- a bearing assembly coupled to said sliding member and received within a groove of a cam.

4. The apparatus of claim 1, wherein said presorting unit further comprises:

- a vibrating mechanism;
- a plurality of transport threads;
- a rotating brush having an axis of rotation perpendicular to the direction of said transport threads;
- at least two aspiration devices configured to provide negative air pressure and coupled to extraction pipes; and
- a control unit for varying the amount of negative air pressure supplied to at least one of said at least two aspiration devices.

5. The apparatus of claim 2, wherein said radial channels have a linear shape.

6. The apparatus of claim 2, wherein said radial channels have an arcuate shape.

7. The apparatus of claim 2, wherein the at least one capsule quality sensor further comprises a microwave sensor.

8. The apparatus of claim 2, wherein the at least one capsule quality sensor further comprises an optical sensor.

9. The apparatus of claim 2, wherein the at least one capsule quality sensor further comprises a laser sensor.

10. The apparatus of claim 2, wherein the at least one capsule quality sensor further comprises an inductive sensor.

11. The apparatus of claim 2, wherein the at least one capsule quality sensor further comprises a capacitive sensor.

12. The apparatus of claim 2, wherein the at least one capsule quality sensor further comprises a video camera.

13. The apparatus of claim 1, wherein said tow gathering funnel further comprises:

- at least one guide member; and
- at least one tongue member.

14. An apparatus for inserting capsules into filter tows, comprising:

- a hopper;
- a presorting unit, said presorting unit further comprising a vibrating mechanism, a plurality of transport threads, a rotating brush having an axis of rotation perpendicular to the direction of said transport threads, at least two aspiration devices configured to provide negative air pressure and coupled to extraction pipes and a control unit for varying the amount of negative air pressure supplied to at least one of said at least two aspiration devices;
- an endless belt disposed between said presorting unit and an inlet pipe;
- an insertion wheel rotating about an axis of rotation, said insertion wheel further comprising a circular cavity in communication with said inlet pipe, a distribution disk disposed within said circular cavity, a plurality of radial channels in communication with said circular cavity, each of said radial channels configured to receive a plurality of capsules, and a plurality of insertion channels, each of said insertion channels being in communication with a corresponding radial channel and terminating at the outer edge of the insertion wheel;
- a plurality of separation mechanisms, each of said plurality of separation mechanisms disposed between a corresponding radial channel and a corresponding insertion channel;
- and a tow gathering funnel, said tow gathering funnel comprising at least one guide member and at least one tongue member, and configured to receive an edge of said insertion wheel.

15. The apparatus of claim 8, wherein each of said plurality of separation mechanisms further comprises:

- a vertical channel in communication with a corresponding radial channel and a corresponding insertion channel;
- a sliding member slidably disposed within said vertical channel, the sliding member comprising a cavity configured to receive a single capsule; and
- a bearing assembly coupled to said sliding member and received within a groove of a cam.

16. The apparatus of claim 1, wherein said capsules have a diameter between approximately 0.5 mm and approximately 8 mm.

17. A method for insertion of capsules into filter tows, comprising:

- placing a plurality of capsules in a hopper of a capsule insertion unit;
- withdrawing said capsules from said hopper;
- determining the quality of said capsules;
- discarding capsules that do not meet desired quality standards;
- distributing said capsules into a plurality of radial channels of an insertion wheel;
- individually separating said capsules; and
- positioning said capsules at a desired position within a filter tow.

* * * * *