



US 20040127985A1

(19) **United States**

(12) **Patent Application Publication**
Bellin et al.

(10) **Pub. No.: US 2004/0127985 A1**

(43) **Pub. Date: Jul. 1, 2004**

(54) **NON-ROTATING BREAST IMPLANT**

Publication Classification

(75) Inventors: **Howard T. Bellin**, New York, NY (US); **Kenneth C. Kredovski**, Roseville, MN (US); **Ruairidh W. Campbell**, Salt Lake City, UT (US)

(51) **Int. Cl.7** **A61F 2/12**

(52) **U.S. Cl.** **623/8; 264/232**

Correspondence Address:
HAUGEN LAW FIRM
SUITE 1130 - TCF TOWER
121 SOUTH EIGHTH STREET
MINNEAPOLIS, MN 55402

(57) **ABSTRACT**

A non-rotating anatomical-shaped breast implant having a front side with a smooth surface and a rear side with a textured surface. A smooth surface ripples or wrinkles little, if at all. Rippling or wrinkling of the implant may undesirably produce a visible or palpable waviness on the skin of the breast. A smooth surface is more likely to produce the look and feel of a natural breast. A rear side with a textured surface is desirable because tissue growth of the body, after the implant has been implanted, engages the textured surface to anchor the implant in place such that the front side with the smooth surface remains matched with the front side of the body and such that the anatomical-shaped breast implant with its tear drop shaped fullness remains at a natural position within the breast. The disclosure further includes a method for minimizing the rotation of an implant within the body and a method for making an implant envelope that has different thicknesses.

(73) Assignee: **Howard T. Bellin**

(21) Appl. No.: **10/734,876**

(22) Filed: **Dec. 12, 2003**

Related U.S. Application Data

(63) Continuation of application No. 09/452,656, filed on Dec. 1, 1999, now Pat. No. 6,692,527.

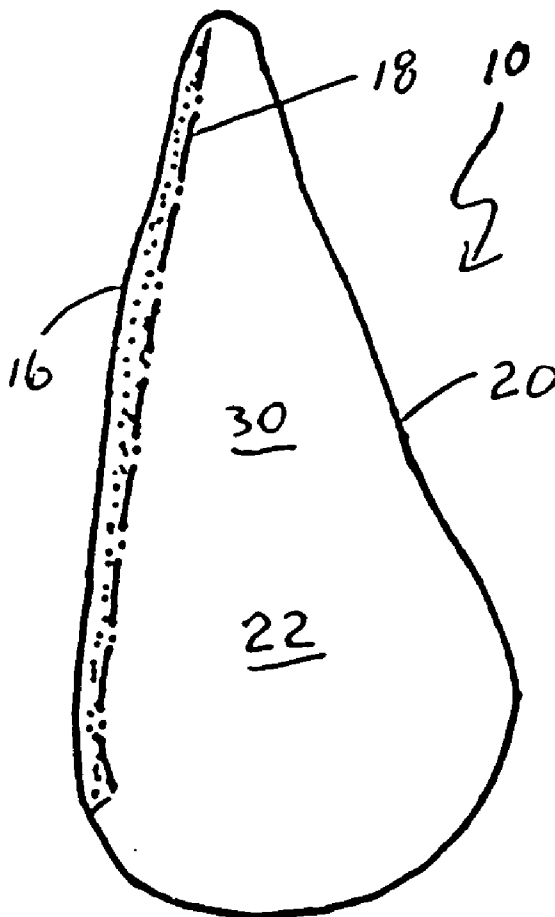

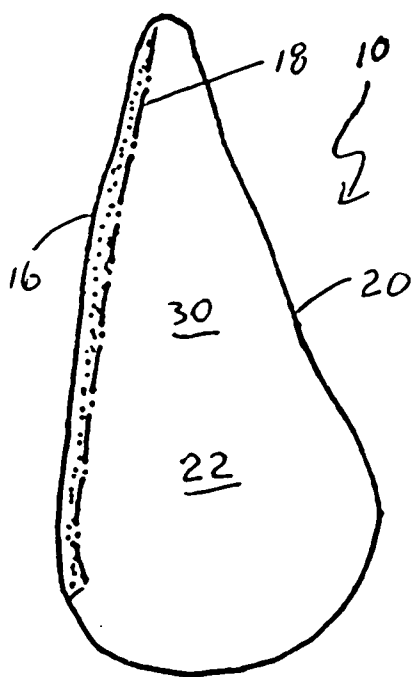
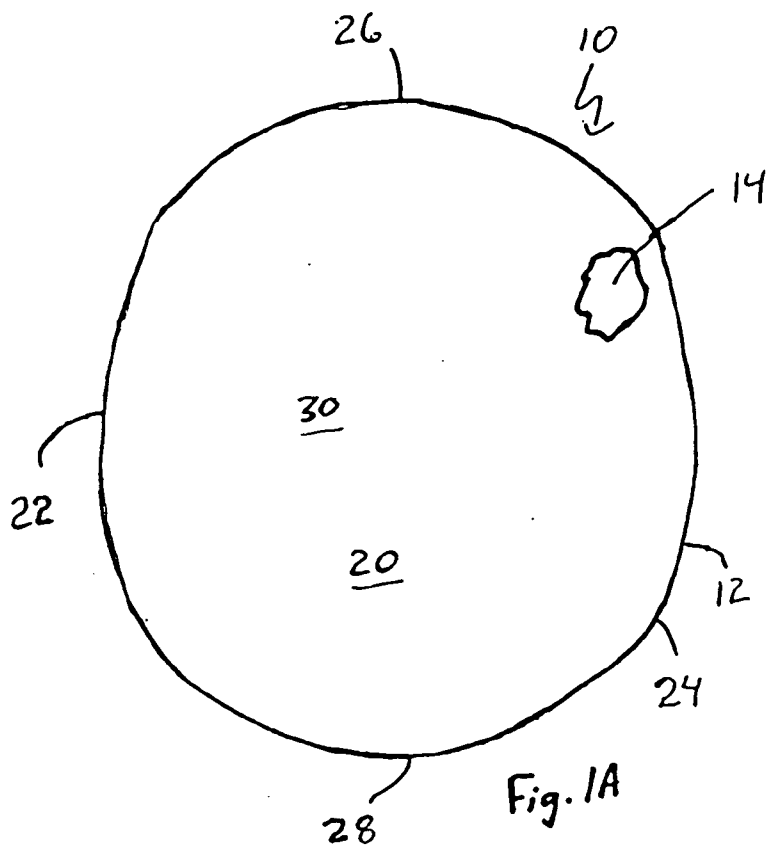
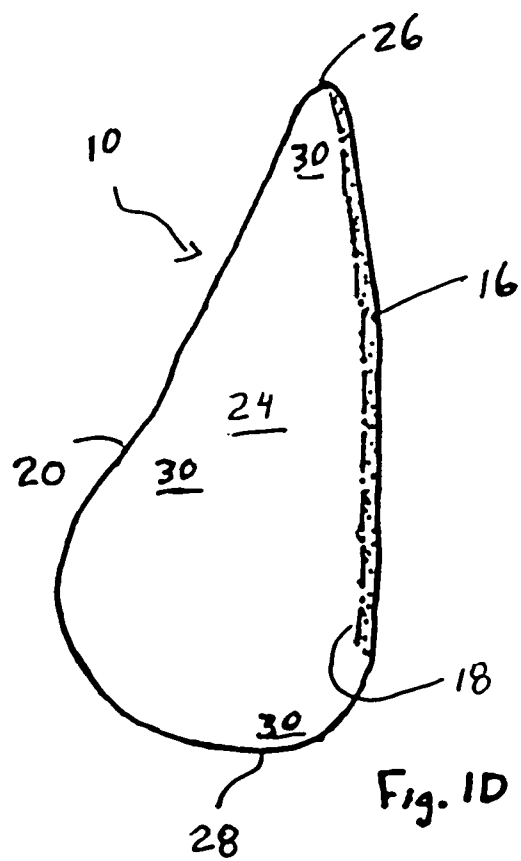
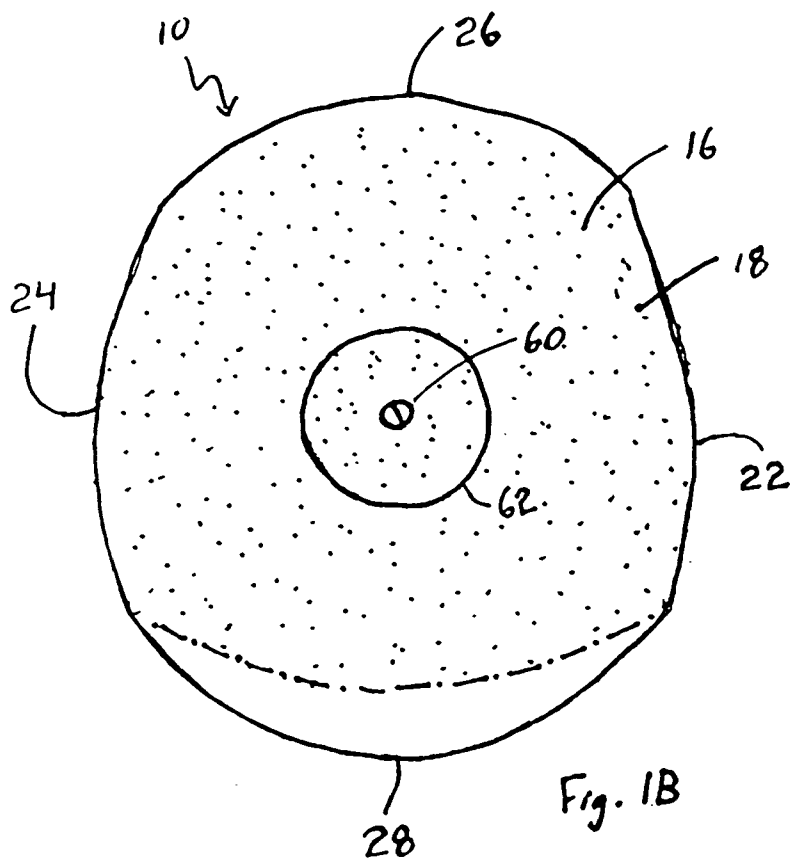
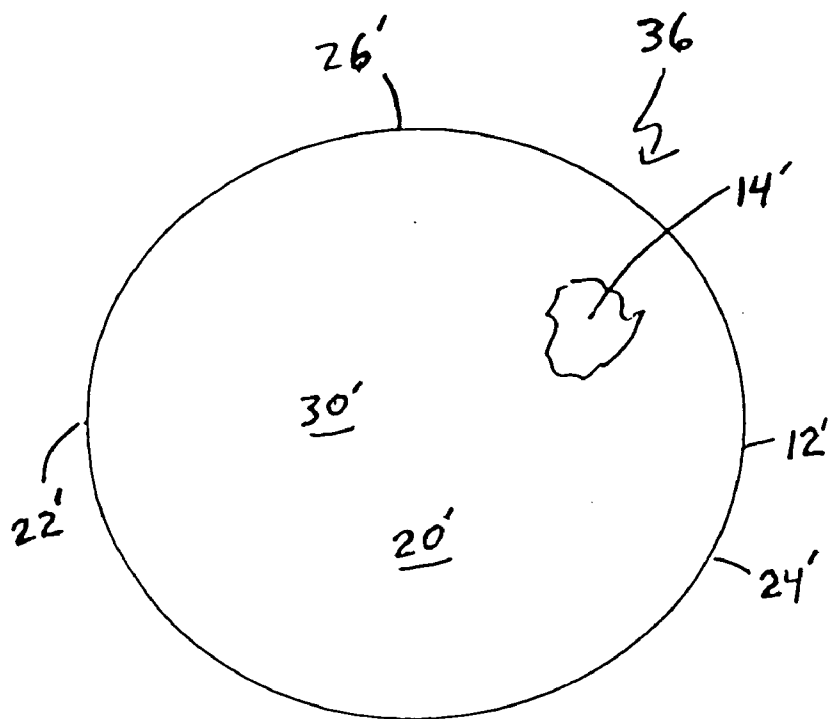

Fig. 1C





28' Fig. 2A

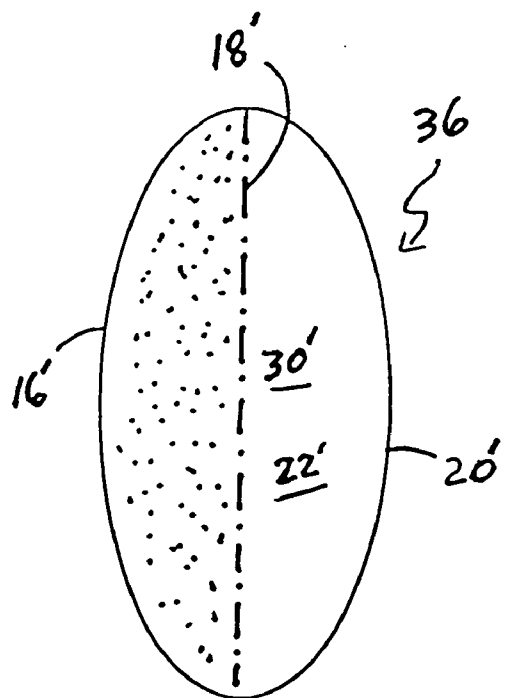
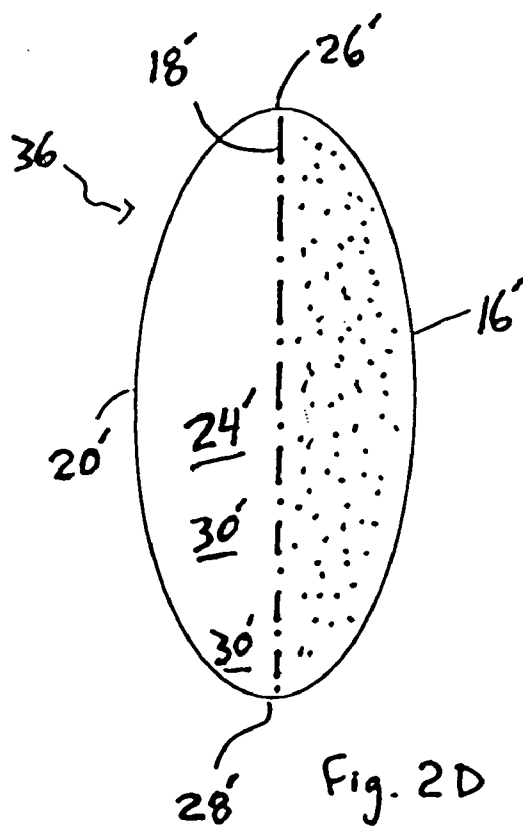
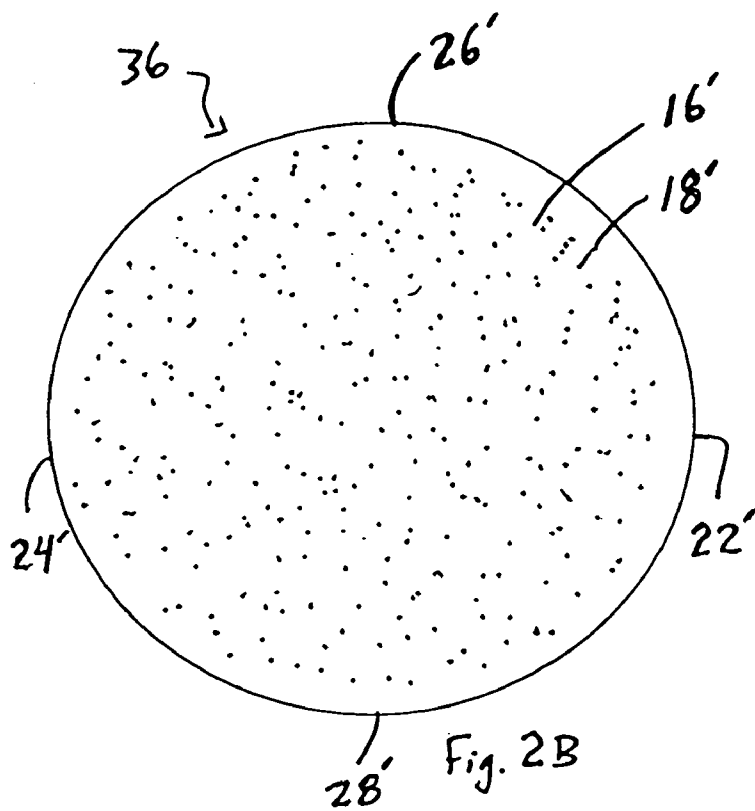
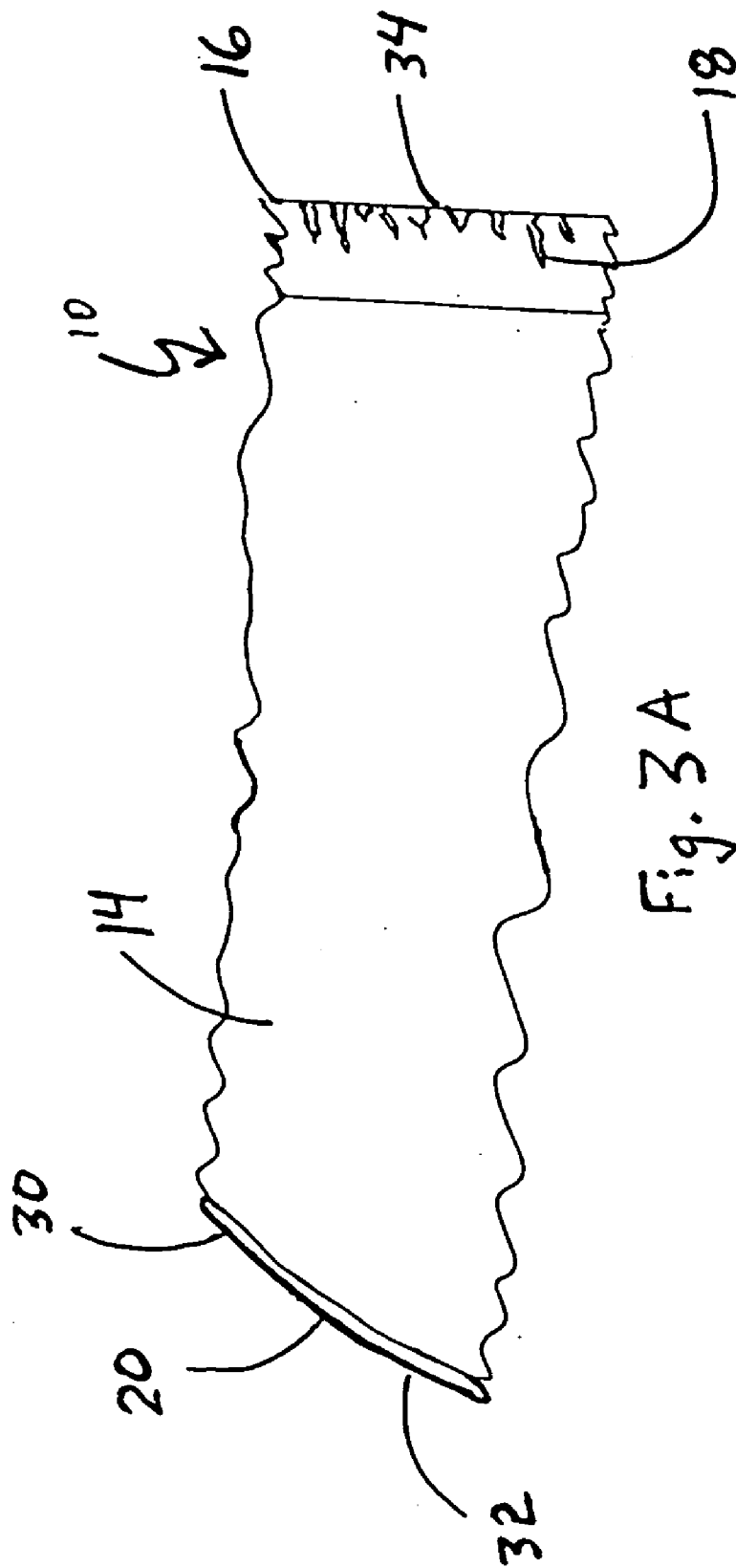

Fig. 2C





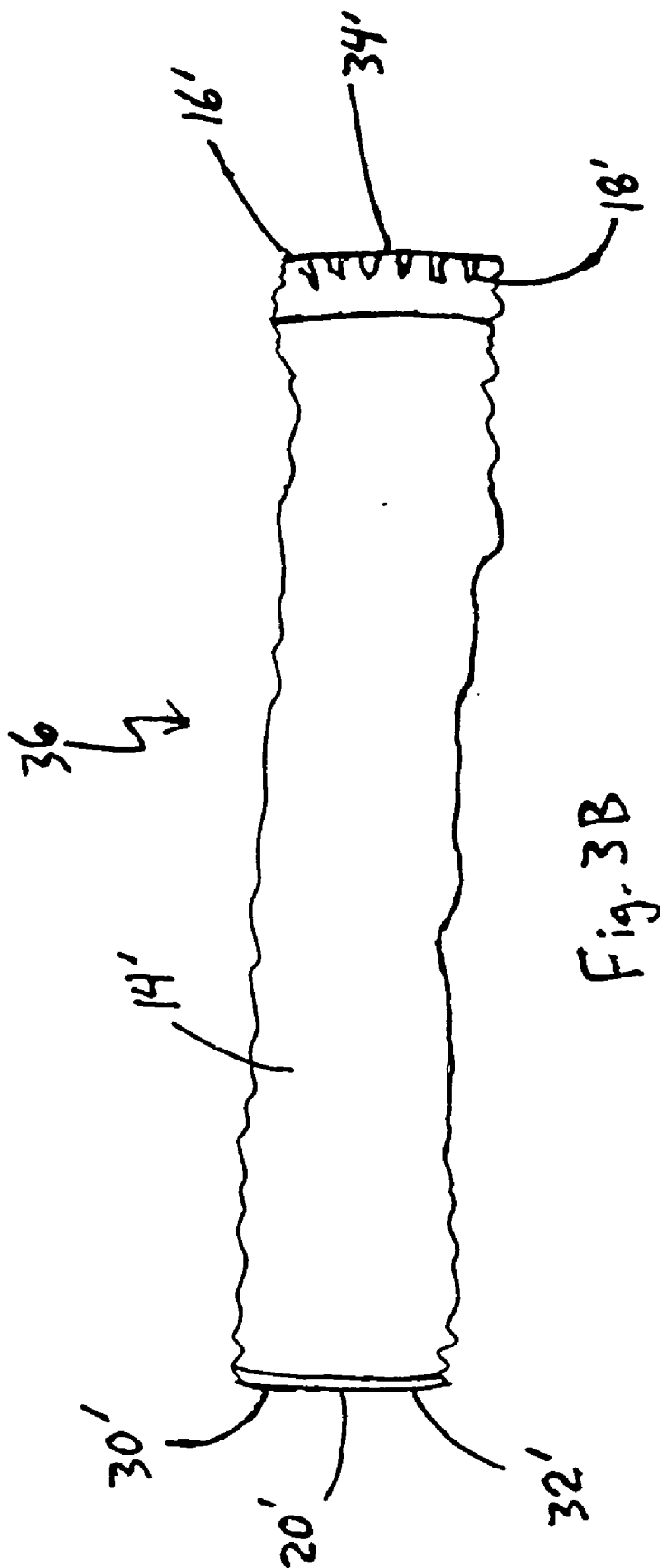

Fig. 3B

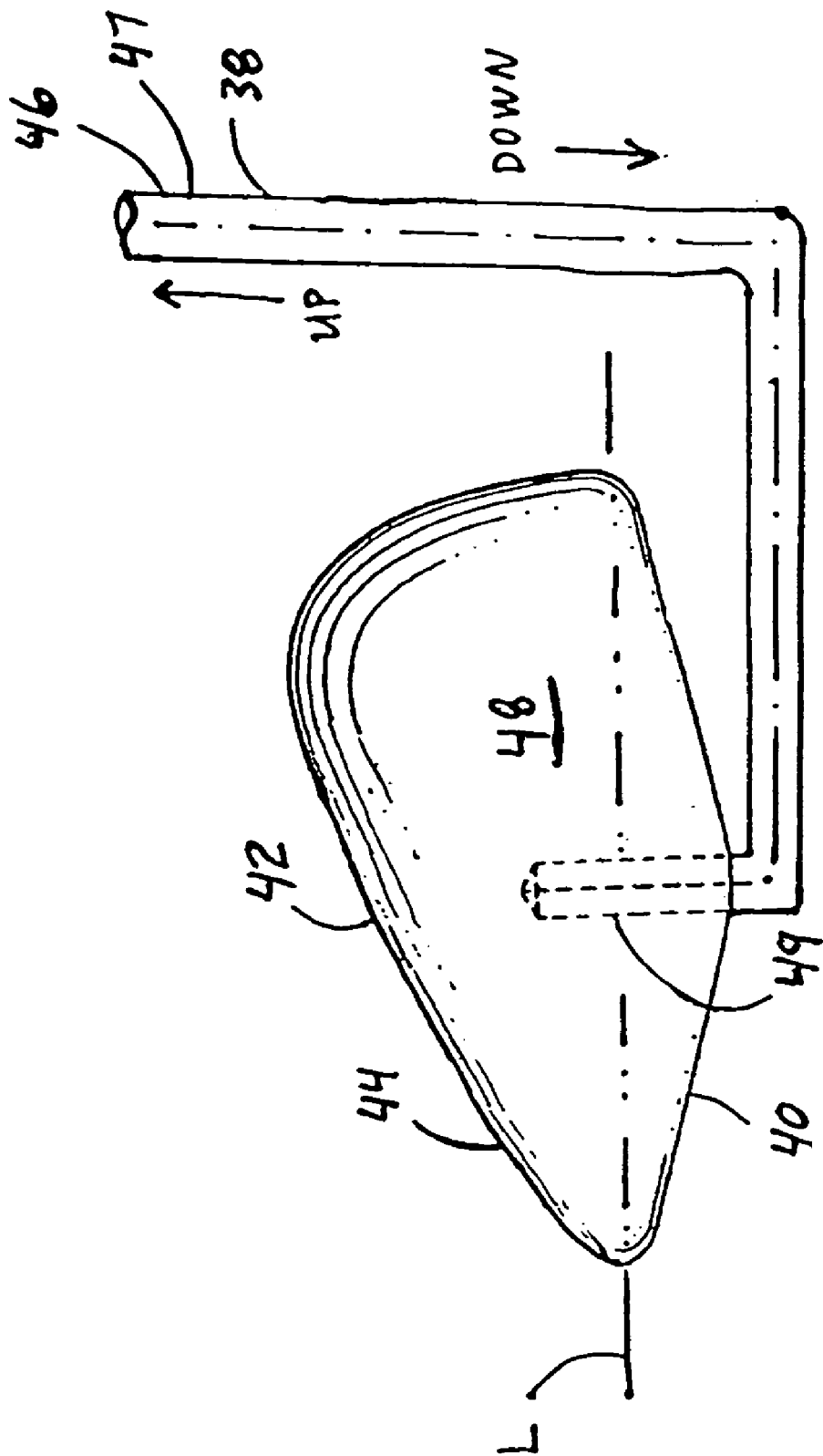
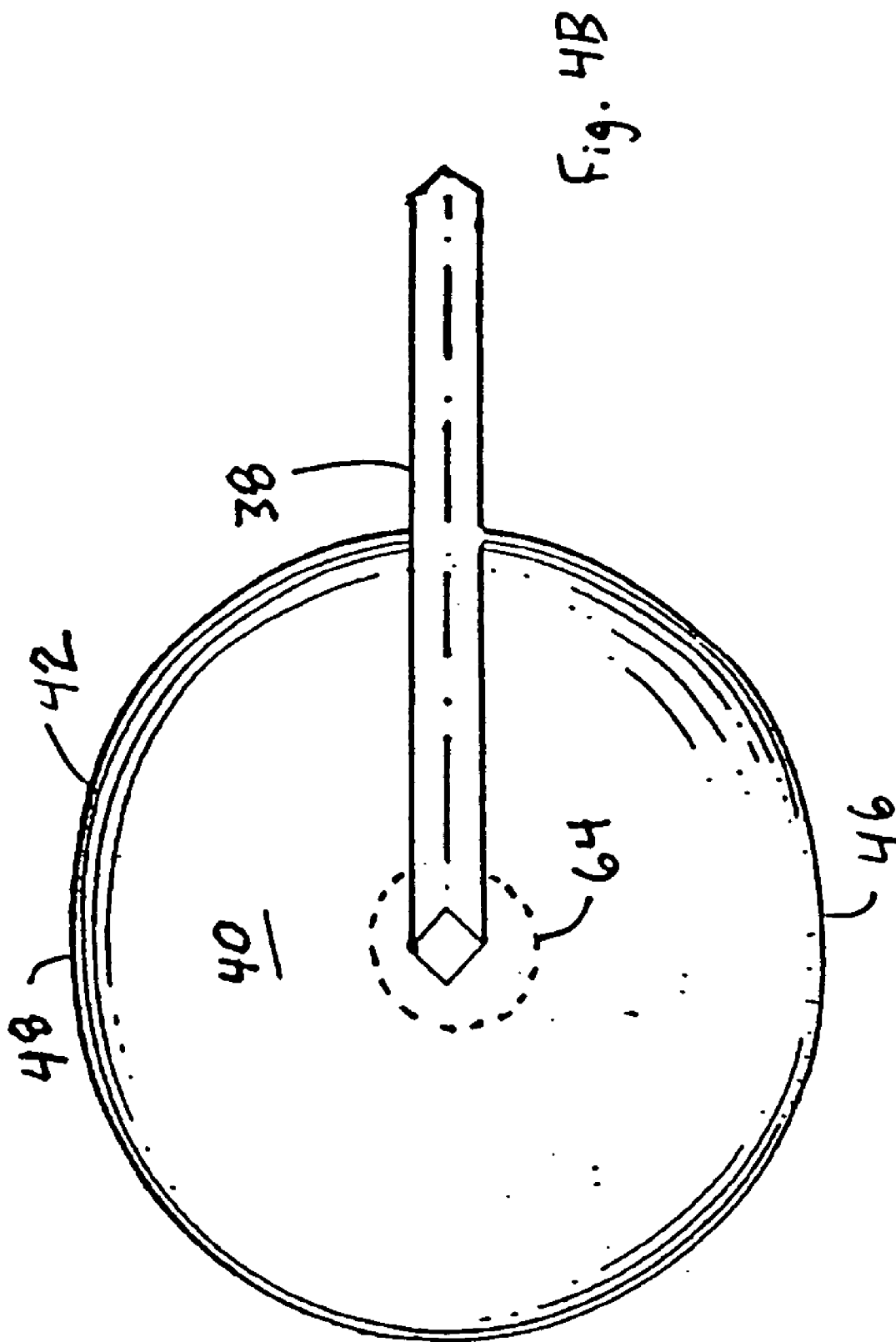

Fig. 4A



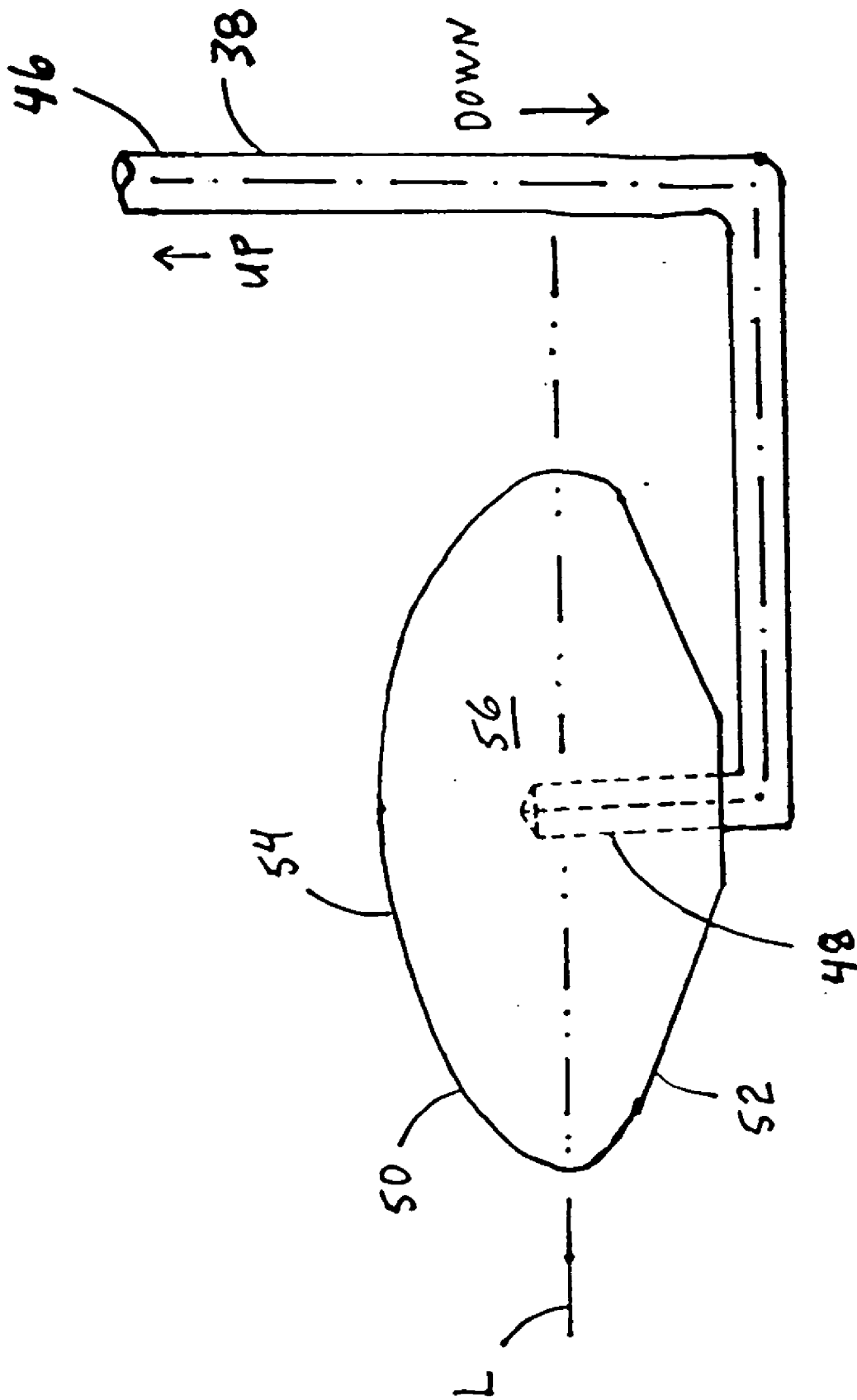
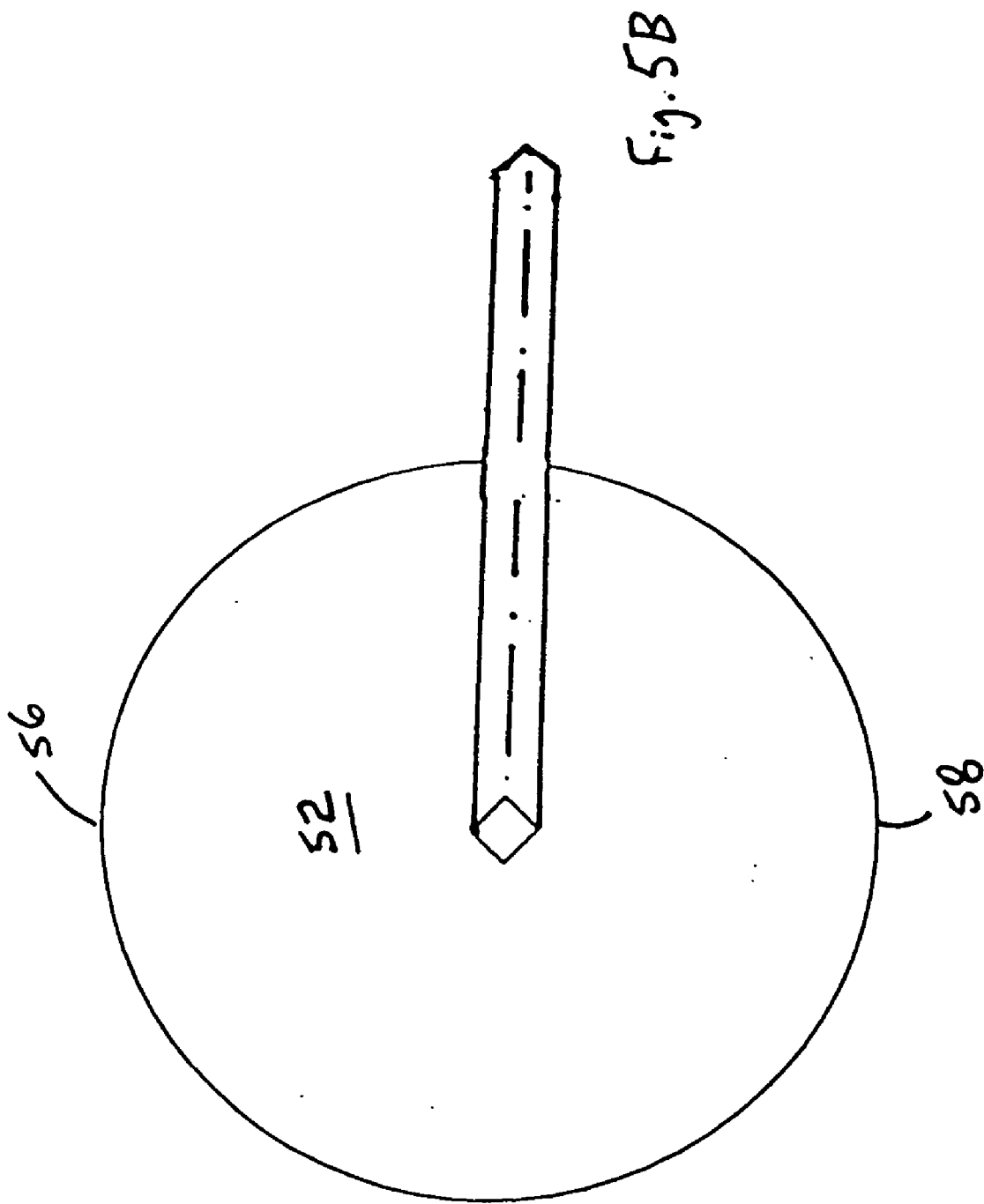
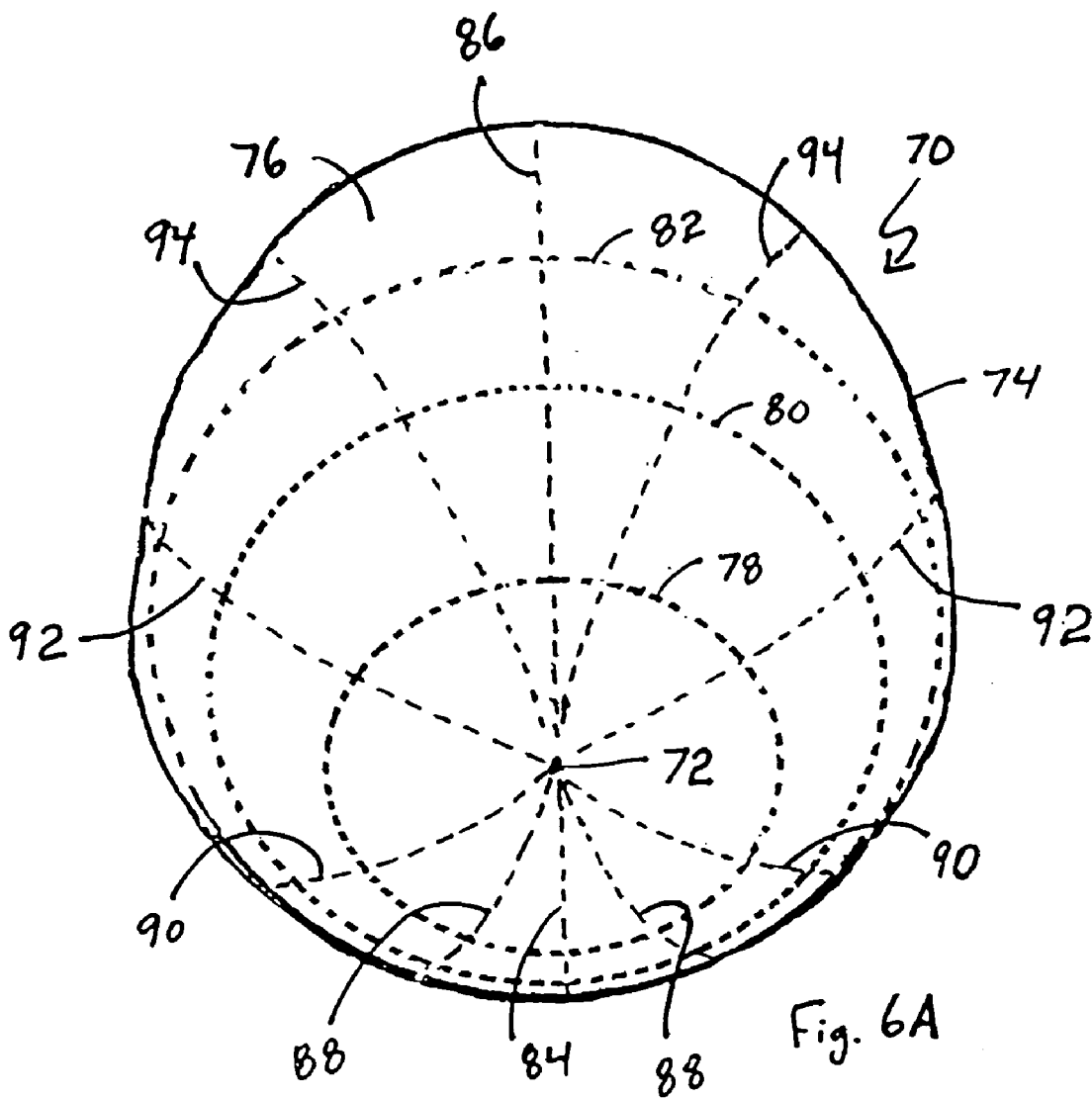
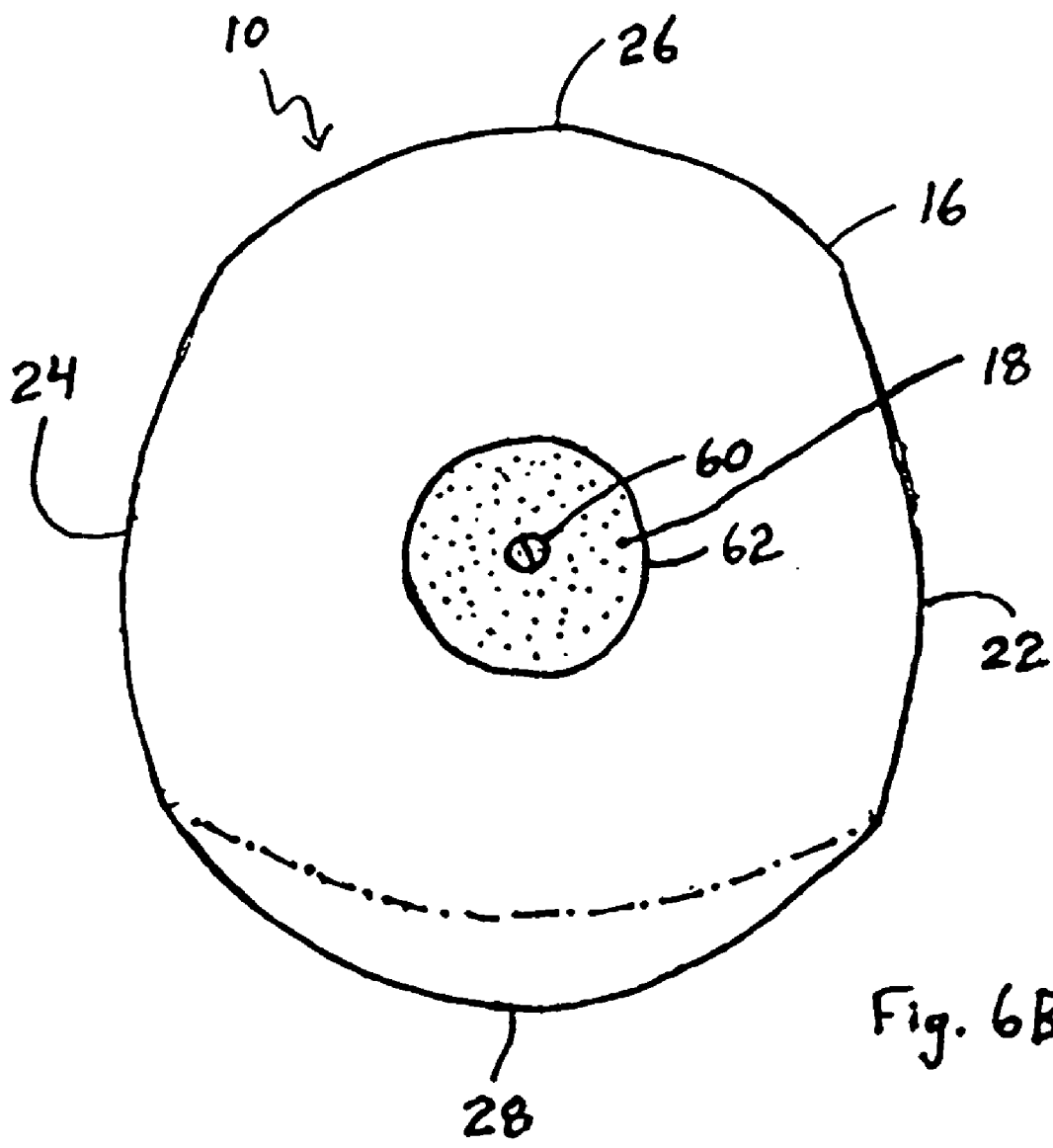

Fig. 5A







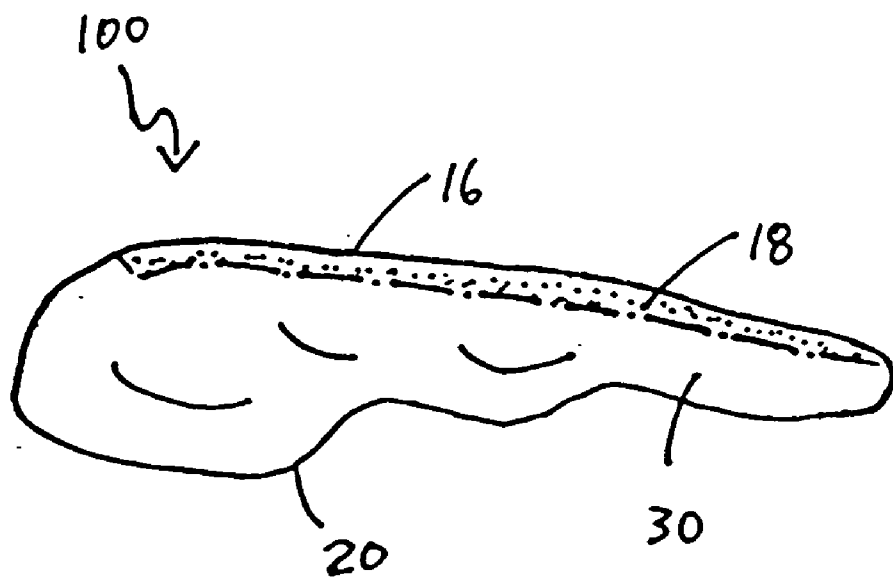

Fig. 7A

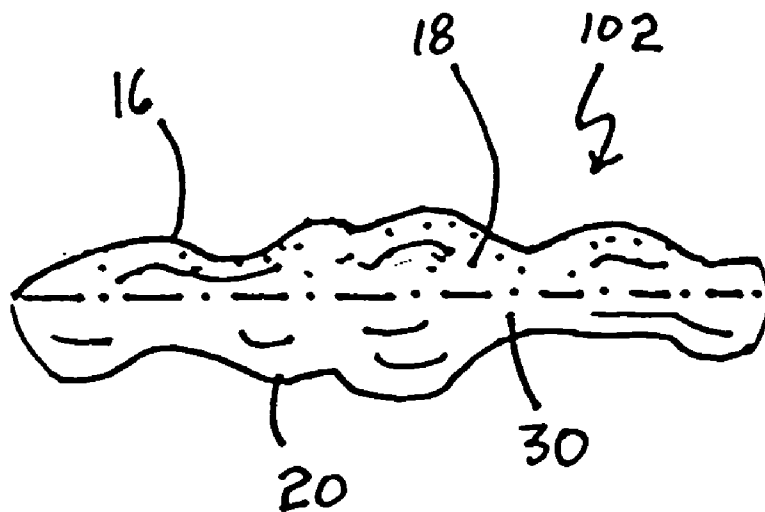

Fig. 7B

NON-ROTATING BREAST IMPLANT

BACKGROUND OF THE INVENTION

[0001] The present invention relates generally to implants for the body and particularly to implants that have features that minimize or prevent rotation of an implant in a body. More specifically, the present invention is a breast implant that has an anatomical shape that gives a more natural look to the augmented breast, but cannot rotate because it has a texturing on the back that anchors it, yet is smooth on the surface to minimize rippling.

[0002] The preferred shape for an implant used for cosmetic breast augmentation is the so-called “anatomical shape” that is also referred to as “tear drop.” This shape has more of the substance filling the silicone elastomer shell in the inferior pole of the implant and less in the superior pole, thus mimicking the natural shape of the breast. For a given volume, round shaped implants have too much substance in the upper pole that can make the breast look artificial. The anatomical implant looks much more natural.

[0003] A problem with anatomical implants is that if the outer surface of the implant is smooth, the implant can rotate. When an implant is surgically placed beneath the breast or beneath the chest muscle, the body recognizes that it is a foreign object and walls it off with tissue that is referred to as a “capsule.” A smooth-walled implant creates a smooth capsule that can allow the implant to slip and slide within it. When a smooth-walled anatomical-shaped breast implant rotates, as it often does, there is more fullness laterally or medially instead of inferiorly as intended. This creates an unacceptable deformity. Thus far the only solution to this problem has been the use of “textured” implants which have a rough surface. They produce a capsule that is reciprocally rough. The “male-female” relationship of the implant and capsule holds the implant in place and prevents its rotation.

[0004] Textured implants have a very distinct disadvantage, however. The problem is that textured implants have a tendency to ripple (i.e. produce a folding, wrinkling or waviness on the surface of the implant). Rippling creates an extremely unsatisfactory appearance. Causes of or factors contributing to rippling may be 1) that textured implants are cured twice, while smooth walled implants are cured once, 2) that the textured implant is formed with an additional coating of the silicone elastomer, leading to a thicker wall that is less able to support itself and thus may fold, and/or 3) the texture itself (peaks and valleys in the surface of the implant) may produce a variety of non-linear scores or fold lines along which the wall of the implant folds or ripples.

[0005] Rippling—visible or palpable waviness on the implant surface—is one of the major problems with breast implants. This folding of the implant can often be felt or seen and can be extremely obtrusive. Therefore, to solve the problem of implant rotation with texturing the entire implant as is presently done, one must compound the problem of severe, unacceptable rippling.

[0006] The present invention provides a solution to the problem. The present invention is an implant that is textured on its posterior surface, but smooth on its anterior surface. The textured posterior surface causes a reciprocal textured capsule, but only behind the implant. This interlocking with

the capsule keeps the implant from rotating. However, the textured area is only on the back of the implant; therefore, any rippling will not be visible or palpable. The anterior surface will remain smooth—and minimize any unsatisfactory rippling.

[0007] Preferred fill materials for the non-rotating anatomical-shaped breast implant include saline and viscous fill materials. Among viscous fill materials, silicone gel, soy oil, and hydrogels are preferred, with hydrogels being most preferred.

SUMMARY OF THE INVENTION

[0008] A feature of the present invention is a non-rotating breast implant.

[0009] Another feature of the present invention is a non-rotating anatomical-shaped breast implant.

[0010] Another feature of the present invention is an implant having a first surface portion that engages tissue in the body to anchor with little or no rotation the implant in the body and a second surface portion that has a desirable characteristic when oriented in a particular direction.

[0011] Another feature of the present invention is an implant having a textured surface portion that engages tissue growth in the body so as to anchor with little or no rotation the implant in the body and a second surface portion that is smooth.

[0012] Another feature of the present invention is a non-rotating anatomical-shaped breast implant with a posterior surface and an anterior surface where the posterior surface comprises a texture to anchor the implant in the body and where the anterior surface comprises a smooth face to minimize wrinkling.

[0013] Another feature of the present invention is a non-rotating breast implant having a first side with a relatively rough surface or surface portion to interlock with body tissue to anchor the implant and having a second side with a relatively smooth surface or surface portion that forms little or no wrinkles and that therefore may be oriented close to the skin to provide a natural appearance.

[0014] Another feature of the present invention is a method for minimizing or preventing rotation of an implant in a body so as to permanently fix the orientation of a desirable characteristic of the implant.

[0015] Another feature of the present invention is a method for minimizing or preventing rotation in a body of an anatomical-shaped implant so as to permanently fix the anterior orientation of the front side of the anatomical-shaped implant.

[0016] Another feature of the present invention is a method of making an envelope for an implant, where the method includes the separate steps of 1) fully submerging and 2) partially submerging a mandrel in a dispersion. The steps may occur in any sequence and be repeated.

[0017] The method includes selecting, preferably, an anatomical-shaped mandrel. Then the mandrel is dipped four times in a dispersion of a silicone elastomer and solvent (such as xylene). After each of the dips, the solvent is permitted to evaporate or partially evaporate so as to permit the just-coated layer to at least partially stabilize. After the

fourth layer of silicone elastomer (or other envelope forming material) has stabilized, the envelope (still on the mandrel) is cured. The cured envelope, still on the mandrel, is then partially dipped into the dispersion, i.e., partially submerged to the level or over the portion of the envelope to which the texturing is to be applied. This layer (over a portion of the envelope) is then permitted to stabilize (but is not fully dried). Then granulated solid particles, such as salt particles (sodium chloride for example), are applied over (such as by being sprayed) the portion of the envelope that has the extra layer of now stabilized but not fully dried silicone elastomer. This portion of the envelope is the portion that is not perceptible (visibly or by touch) when the implant is implanted into the body. Preferably, such portion of the implant is the posterior side of the implant. Then the envelope is cured (vulcanized). After being cured, the envelope (still on the mandrel) is soaked in a solvent (such as water) to dissolve or wash off the solid granules, thereby leaving the textured surface. The envelope is then removed from the mandrel, patched and fitted with a valve for the fill material.

[0018] Another feature of the present invention is a breast implant having a first thickness at the nipple position and a second thickness on the posterior side.

[0019] An advantage of the present invention is that anatomical-shaped breast implants are held in position, with their superior poles correctly oriented in the superior position without slippage or spin off in the medial or lateral directions.

[0020] Another advantage of the present invention is that the anterior side of the breast implant takes on a more natural appearance and feel. Since the implant is anchored in place by tissue engaging the textured posterior side of the implant, the anterior side of the implant need not be textured and therefore may be made of a thinner envelope wall having a smooth surface. Thinner, smooth, once-cured envelope walls have less of a tendency to wrinkle or ripple than do thicker, textured, twice-cured walls. A wrinkle or ripple may be seen and/or felt through the skin of the natural breast.

BRIEF DESCRIPTION OF THE DRAWINGS

[0021] FIG. 1A shows the front side (or anterior side or face) of an anatomical-shaped breast implant.

[0022] FIG. 1B shows the rear side (or posterior side or face) of the anatomical-shaped breast implant of FIG. 1A.

[0023] FIG. 1C shows the right side (medial or lateral side dependent upon which breast) of the breast implant of FIG. 1A.

[0024] FIG. 1D shows the left side (medial or lateral side dependent upon which breast) of the breast implant of FIG. 1A.

[0025] FIG. 2A shows the front side (or anterior side or face) of a round-shaped breast implant.

[0026] FIG. 2B shows the rear side (or posterior side or face) of the round-shaped breast implant of FIG. 2A.

[0027] FIG. 2C shows the right side (medial or lateral side dependent upon which breast) of the breast implant of FIG. 2A.

[0028] FIG. 2D shows the left side (medial or lateral side dependent upon which breast) of the breast implant of FIG. 2A.

[0029] FIG. 3A shows a cross section of the implant of FIG. 1A to show the relatively thin wall of the anterior side of the implant and the relatively thick wall of the posterior side of the implant, and further shows fill material in the implant.

[0030] FIG. 3B shows a cross section of the implant of FIG. 2A to show the relatively thin wall of the anterior side of the implant and the relatively thick wall of the posterior side of the implant, and further shows fill material in the implant.

[0031] FIG. 4A shows a side view of a mandrel for the anatomical-shaped implant of FIG. 6A, and further shows a dipping rod engagable with the rear side of the mandrel.

[0032] FIG. 4B shows a bottom view of the mandrel and, dipping rod of FIG. 4A.

[0033] FIG. 5A shows a side view of a mandrel for the round shaped implant of FIGS. 2A-D.

[0034] FIG. 5B shows a bottom view of the mandrel of FIG. 5A.

[0035] FIG. 6A shows a front or anterior view of an anatomical-shaped breast implant formed using the mandrel of FIGS. 4A and 4B.

[0036] FIG. 6B shows a rear or posterior view of the anatomical-shaped implant of FIGS. 1A-D having only a portion of its surface textured.

[0037] FIG. 7A shows a side view of an inflatable anatomical shaped implant having a textured posterior surface.

[0038] FIG. 7B shows a side view of an inflatable round shaped implant having a textured posterior surface.

DETAILED DESCRIPTION OF THE PREFERRED EMBODIMENTS

[0039] As shown in FIGS. 1A-D and 3A, an anatomical-shaped breast implant is designated in general by reference number 10. The implant 10 includes an envelope 12 and fill material 14 sealed in the envelope 12. The envelope 12 further includes a posterior (rear) side or face 16 that includes a textured or relatively rough surface 18 and an anterior (front) side or face 20 that is smooth or relatively smooth compared to the relatively rough surface 18. The envelope 12 further includes a right side 22 (shown in FIG. 1C) and a left side 24 (shown in FIG. 1D). Depending upon the breast into which the implant 10 is implanted, the right side 22 may be the medial or lateral side of the implant 10 and the left side 24 may be the medial or lateral side of the implant 10. The implant 10 further includes a superior (upper) pole 26 and an inferior (lower) pole 28. The anterior (front) side 20 of the envelope 12 has a smooth surface 30, relatively thin wall 32 and is cured once (though subject twice to curing temperatures). Most (over about 90%) of the right side 22 of the envelope 12 and most (over about 90%) of the left side 24 of the envelope 12 has a smooth surface 30 and a relatively thin wall portion 32 that is cured once (though is subject twice to curing temperatures). Further, the smooth surface 30 and the relatively thin wall portion 32 extend about a portion of each of the superior (upper) pole

26 and inferior (lower) pole 28. The posterior (rear) side 16 is formed by a relatively thick wall 34 of the envelope 12 that is textured and that is cured twice.

[0040] While it is preferable that an anatomical-shaped breast implant includes the features of the present invention, it should be noted that the features of the present invention may be used in an alternate embodiment of the invention, specifically a round shaped implant 36 shown in FIGS. 2A-D and 3B. The reference numbers of the anatomical-shaped implant 10 are noted on the round shaped implant 36 as prime reference numbers. In other words, the round shaped implant 36 includes an envelope 12' and fill material 14' sealed in the envelope 12'. The envelope 12' further includes a posterior (rear) side or face 16' that includes a textured surface 18' and an anterior (front) side or face 20' that is smooth. The envelope 12' further includes a right side 22' (shown in FIG. 2C) and a left side 24' (shown in FIG. 2D). Depending upon the breast into which the implant 36 is implanted, the right side 22' may be the medial or lateral side of the implant 36 and the left side 24' may be the medial or lateral side of the implant 36. The implant 36 further includes a superior (upper) pole 26' and an inferior (lower) pole 28'. The anterior (front) side 20' of the envelope 12' has a smooth surface 30', relatively thin wall 32' and is cured once (though subject twice to curing temperatures). One-half of the right side 22' of the envelope 12' and one-half of the left side 24' of the envelope 12' has a smooth surface 30' and a relatively thin wall portion 32' that is cured once (though subject twice to curing temperatures). Further, the smooth surface 30' and the relatively thin wall portion 32' extend about a portion of each of the superior (upper) pole 26' and inferior (lower) pole 28'. The posterior (rear) side 16' is formed by a relatively thick wall 34' of the envelope 12' that is textured and cured twice. As further shown in FIGS. 2A-D and unlike with the anatomical-shaped implant 10 of FIGS. 1A-D, one-half of the right side 22' has the textured surface 18' and one-half of the left side 24' has the textured surface 18'. Further, one-half of the surface about each of the poles 26' and 28' is the textured surface 18' and the other one-half of the pole surface is the smooth surface 30.

[0041] The envelope 12 is preferably formed of a material that is biocompatible, flexible, resilient and is substantially impermeable to the transport of water vapor. Rubber, such as a silicone elastomer, is a preferred material. The envelope 12 may also include a polymeric or copolymeric water vapor barrier layer that is extremely impermeable to the transport of water vapor and that has greater water vapor impermeability than a rubber such as a silicone elastomer. As to extremely impermeable water vapor barrier layers for implants, the following U.S. Patent is hereby incorporated by reference in its entirety: U.S. Pat. No. 5,630,844 issued May 20, 1997 and entitled Biocompatible Hydrophobic Laminate With Thermoplastic Elastomer Layer.

[0042] The present breast envelope is formed by dipping a mandrel into a silicone rubber dispersion. A dispersion may contain a silicone elastomer and a solvent (such as xylene). The mandrel is completely submerged and then raised out of the dispersion with a thin coating of the dispersion adhering to the mandrel. It should be noted that the first layer (formed by the first dip) is relatively thin since the dispersion flows readily off the smooth surface of the mandrel. The solvent is then caused to evaporate, such as with heat and/or by having air blown over the drying

mandrels, and then the same mandrel having a layer of partially dried or at least partially stabilized silicone elastomer is dipped again (and allowed to at least partially stabilize) and again (and allowed to at least partially stabilize) until the desired thickness is obtained. In other words, after each of the first three dips, the envelope is ready to be dipped again when the partially stabilized just-coated layer has a certain tackiness, i.e. may leave a clear definition of a fingerprint without the finger picking up much if any of the dispersion (about 15 minutes after being dipped). After the fourth dip, the envelope of four layers is cured (still on the mandrel) at about 270° F. for about 90 minutes. Then the cured envelope of four layers is cooled to room temperature and inspected for waviness, bubbles and foreign material. The thickness of the final cured envelope is about $\frac{12}{1000}$ (0.012) inches thick to about $\frac{19}{1000}$ (0.016) inches thick.

[0043] As to making a breast envelope, the following U.S. Patents are hereby incorporated by reference in their entireties: U.S. Pat. No. 5,674,285 issued Oct. 7, 1997 and entitled Mammary Implant Having Shell With Unitary Rough-Textured Outer Layer and U.S. Pat. No. 5,630,844 issued May 20, 1997 and entitled Biocompatible Hydrophobic Laminate With Thermoplastic Elastomer Layer.

[0044] As to making the envelope of the present invention with a relatively thin wall (such as thin wall 32) and a relatively thick wall (such as thick wall 34), please see FIGS. 4A and 4B. Here a generally U-shaped dipping rod 38 extends into the posterior side 40 of a mandrel 42. Mandrel 42 includes an anterior side 44. Mandrel 42 may be used to make the anatomical-shaped implant 70 of FIG. 6A. U-shaped dipping rod 38 includes a proximal end 47 (that may engage a handle for being manually dipped or that may engage an automatic dipping apparatus) and a distal end 49 that runs into the mandrel 42. Dipping rod 38 has a cross section that is square or diamond-shaped and runs into a square or diamond-shaped hole in the posterior side 40 of the mandrel 42 to minimize unintended spinning of the mandrel 42 relative to the dipping rod 38. With the U-shaped dipping rod 38, the posterior side 40 only of the mandrel 42 is dipped to level L into the dispersion (of a silicone elastomer and solvent) to the exclusion of anterior side 44 of the mandrel 42, further to the exclusion of over about 75% of a right side 46 (i.e. lateral or medial side depending upon the breast into which the implant is implanted) and further to the exclusion of over about 75% of a left side 48 (i.e. lateral or medial side depending upon the breast into which the implant is implanted) of the mandrel 42. Such a partial dip may be the first dip in a dipping process to form an envelope of the present invention, such as envelope 12. Preferably, such a partial dip is the last dip in the dipping process. Still further if desired, such a partial dip may be one of the "in-between" dips. Also, such a partial dip may not be limited to one partial dip. There may be two or more of such partial dips where only the posterior side 40 is dipped into the dispersion. After each partial dip or after each full dip, the solvent is permitted to evaporate and the mandrel 42 is again dipped into the dispersion until the anterior wall (such as wall 32) is the desired thickness and the posterior wall (such as wall 34) is the desired thickness.

[0045] Envelope 12' is formed in an identical manner, except that the mandrel 50 of FIG. 5A is used. Mandrel 50 produces the round shaped implant 36 of FIGS. 2A-D. Mandrel 50 includes a posterior side 52, an anterior side 54,

a right side **56** (i.e. lateral or medial side depending upon the breast into which the implant is implanted), and a left side **58** (i.e. lateral or medial side depending upon the breast into which the implant is implanted) corresponding to the posterior side **16'**, anterior side **20'**, right side **22'**, and left side **24'** of implant **36**. Mandrel **50** is fully submerged four times, then cured, then partially submerged to level L to form the posterior wall, then the posterior wall is sprayed with granulate sodium chloride, and then the envelope is cured and soaked in water to rid the envelope of the sodium chloride and expose the textured surface on the posterior wall.

[**0046**] Preferably, as to making the envelope **12** with a relatively thin wall **32** and a relatively thick wall **34** having the textured surface **18**, a mandrel is dipped four times in the dispersion as described above and the envelope is then cured (still on the mandrel) at about 270° F. for about 90 minutes. Then the four-layer envelope and mandrel is cooled to room temperature and inspected. If the envelope passes inspection, the envelope is partially dipped, such that only about the posterior side of the envelope is submerged in the dispersion. Then the mandrel having the partial fifth layer is permitted to sit at room temperature for about 2.5 minutes to about 5 minutes, whereupon the fifth layer is sprayed with sodium chloride, which embeds itself in the fifth partially stabilized layer. Then the mandrel having the fifth partial layer embedded with sodium chloride is cured at about 270° for about 90 minutes. Then the cured envelope (still on the mandrel) is soaked in water for four to twelve hours or more to dissolve the sodium chloride to remove it from the envelope and expose the texture. Then the envelope is removed from the mandrel and patched. The patch may include a valve for feeding the fill material to the interior of the envelope. Or the valve may be placed at another site on the envelope.

[**0047**] As to applying the textured surface **18** to implant **10** or **36**, the following U.S. Patents are hereby incorporated by reference in their entireties: 1) U.S. Pat. No. 5,674,285 issued Oct. 7, 1997 and entitled Mammary Implant Having Shell With Unitary Rough-Textured Outer Layer and 2) U.S. Pat. No. 5,022,942 issued Jun. 11, 1991 and entitled Method Of Making Textured Surface Prosthesis Implants.

[**0048**] As to the fill material **14**, preferred fill materials include saline and silicone gel. More preferably, the fill material is a biocompatible responsive gel. As to biocompatible responsive gels, the following U.S. Patent is hereby incorporated by reference in its entirety: U.S. Pat. No. 5,662,708 issued Sep. 2, 1997 and entitled Rheologically Modified And Osmotically Balanced Fill Material For Implant.

[**0049**] The relative thicknesses of the anterior and posterior walls in **FIGS. 3A and 3B** are exaggerated for clarity. In practice, anterior wall **32** is preferably between about $1\frac{2}{1000}$ (0.012) inches thick and about $1\frac{6}{1000}$ (0.016) inches thick. Posterior wall **34** is preferably between about $1\frac{4}{1000}$ (0.014) inches thick and about $1\frac{8}{1000}$ (0.018) inches thick. The posterior wall **34** is preferably about $\frac{2}{1000}$ (0.002) inches thicker than the anterior wall **32**. Anterior wall **32'** is preferably between about $1\frac{2}{1000}$ (0.012) inches thick and about $1\frac{6}{1000}$ (0.016) inches thick. Posterior wall **34'** is preferably between about $1\frac{4}{1000}$ (0.014) inches thick and

about $1\frac{8}{1000}$ (0.018) inches thick. The posterior wall **34'** is preferably about $\frac{2}{1000}$ (0.002) inches thicker than the anterior wall **32'**.

[**0050**] The present implants may include room temperature vulcanized (RTV) envelopes. These envelopes are conventionally used with saline fill materials. Saline fill materials tend to be more abrasive, and RTV envelopes resist the abrasiveness of the saline to a better degree than do envelopes that are cured at elevated temperatures. In other words, an RTV envelope may include a textured portion (such as on a posterior portion) and a portion with a smooth surface (such as on an anterior portion).

[**0051**] The present implants are preferably breast implants and, more preferably, anatomical-shaped breast implants. Anatomical-shaped implants have a greater fullness in the inferior pole. Or the anatomical-shaped implant may have a fullness in the inferior pole as shown by implant **70** in **FIG. 6A**. Here, in **FIG. 6A**, the roundness or elevation of the implant is shown by phantom lines. The "highest" point on implant **70** is shown by point or nipple region **72** and reference numeral **74** shows a line marking the boundary between the anterior side **76** and the posterior side of implant **70**. Loops **78**, **80** and **82** mark respective "elevations" between nipple region **72** and boundary line **74** such that the breast implant surface along phantom line **84** has the greatest slope and such that the breast implant surface along phantom line **86** has the least slope. The breast implant surfaces along phantom lines **88** have a progressively lesser slope than the surface along phantom line **84**, and these progressively lesser slopes continue between and along surface lines **90**, **92**, and **94**, which lines also radiate from the nipple region **72**.

[**0052**] The valve for filling the implant with fill material may be located either posteriorly or anteriorly. A posterior valve **60** is shown in **FIG. 1B**. The valve **60** may be a leaf valve.

[**0053**] As shown in **FIG. 1B**, valve **60** is engaged to a patch **62**. Patch **62** is a piece of silicone elastomer that is vulcanized to the envelope after the envelope has been removed from the mandrel. In other words, the envelope is first formed by 1) dipping the mandrel four times so as to produce a four layer envelope 2) curing the envelope so that the envelope is vulcanized to a one layer envelope, 3) partially dipping the mandrel and spraying the partial layer with granulate sodium chloride, 4) curing the envelope so that the partial layer is vulcanized to the envelope, 5) and then soaking the envelope to remove the granulate sodium chloride and expose the texture. Then the dipping rod **38**, including distal end **49**, is removed from the mandrel. A ragged piece of the envelope remains about the area where the distal end **49** had engaged and had been removed from the mandrel. This ragged piece is cut about a line **64**, shown in phantom in **FIG. 4B**. Then the envelope is stretched about the opening left by such cutting such that the mandrel passes through the stretched opening. Then valve **60** is anchored to patch **62**. Then patch **62** having valve **60** is vulcanized to the envelope about the opening.

[**0054**] The surface of the patch **62** may, if desired, be the only portion of the implant that is textured, as shown in **FIG. 6B**. The texture **18** of this patch **62** sufficiently interlocks with body tissue to minimize, if not prevent, rotation of implant **10** in the body. Patch **62** has a diameter of about 25% of the diameter of the implant **10**.

[0055] The area of the surface texture **18** for interlocking with body tissue for anchoring an implant to minimize or even prevent rotation preferably has a surface area of between about 5% and about 50% of the total surface area of the implant, more preferably between about 5% and about 40% of the total surface area of the implant, and most preferably between about 5% and about 30% of the total surface area of the implant. The surface area of the patch **62** is about 5% of the total surface area of the implant **10** shown in **FIG. 6B**. The surface area of the texture **18** of the round-shaped implant **36** is about 50% of the total surface area of implant **36**. The surface area of the texture **18** on the posterior side of implant **10** in **FIG. 1B** is about 30% of the total surface area of the implant **10** of **FIGS. 1A-D**.

[0056] Preferably, the area of the surface texture **18** is on one side or on less than one side of the implant and covers one portion or block of surface of the implant without breaks in the texturing. However, if desired, the surface texture **18** may form an annular band about the circumference of the implant, or an annular band along less than the circumference of the implant, or a band having two ends along one side of the implant, or a band having two ends along less than one side of the implant. Such bands of texturing may be formed, for example, by placing a template over a partially stabilized but not cured envelope, then spraying the granulate sodium chloride over the template and exposed portion of the partially stabilized but not cured envelope, then removing the template, then curing the envelope, and then soaking the envelope to remove the salt and expose the band of texture.

[0057] It should be noted that preferably the textured surface **18** has an aggressive texture and that preferably the smooth surface **30** is perfectly smooth or as perfectly smooth as is practically possible through the process of dipping and curing a silicone elastomer breast envelope. However, if desired, surface **18** may be relatively rough and surface **30** may be relatively smooth. In other words, it should be noted that some texture applied to implant surfaces is very aggressive (has high peaks and low valleys, i.e., the absolute distance between the peaks and valleys is great), that some texture applied to implant surfaces is subtle (has low peaks and high valleys, i.e., the absolute distance between the peaks and valleys is small), and that some texture is not so aggressive and not so subtle.

[0058] An aggressive texture performs best for anchoring an implant and such is preferred for a posterior side of a breast implant. On the anterior side of such an implant, a perfectly smooth surface or practically smooth surface is preferred. However, if desired, a less aggressive or subtle texture (i.e. relatively smooth surface) may be used.

[0059] As to forming an implant having both an aggressive texture and a less aggressive texture, one side or one portion of the envelope may be sprayed with relatively coarse granules of sodium chloride and the other side or other portion of the envelope may be sprayed with relatively fine particles of sodium chloride. Then the envelope is cured and soaked to remove the salt and expose the texture. The coarse particles produce the relatively aggressive texture. The fine particles produce the relatively subtle texture.

[0060] The present implants may be inflatable or prefilled implants. In other words, either an inflatable implant or a prefilled implant may include a textured surface portion

(such as on a posterior portion) and a portion with a smooth surface (such as on an anterior portion). An inflatable anatomical shaped implant **100** is shown in **FIG. 7A** having no fill material therein. Implant **100** includes posterior face **16** with texture **18** and an anterior face **20** and smooth surface **30**. An inflatable round shaped implant **102** is shown in **FIG. 7B** having no fill material therein. Implant **102** includes posterior face **16** with texture **18** and an anterior face **20** and smooth surface **30**. Implants **100** and **102** are manufactured according to the processes described above. Generally, inflatable implants are surgically implanted into the body and then filled with fill material so as to expand the implant. Prefilled implants are filled at the factory with fill material or filled with fill material prior to being surgically implanted. The implants shown in **FIGS. 1A, 1B, 1C, 1D, 2A, 2B, 2C, 2D, 6A** and **6B** show prefilled implants.

[0061] Thus since the invention disclosed herein may be embodied in other specific forms without departing from the spirit or general characteristics thereof, some of which forms have been indicated, the embodiments described herein are to be considered in all respects illustrative and not restrictive. The scope of the invention is to be indicated by the appended claims, rather than by the foregoing description, and all changes which come within the meaning and range of equivalents of the claims are intended to be embraced therein.

What is claimed is:

1. A breast implant for being implanted within a body, wherein the body includes front, rear, right and left sides, wherein the breast implant comprises:

- a) an envelope having at least two sides, wherein the envelope is fillable with fluid to provide a three-dimensional shape to the envelope;
- b) wherein one of the sides of the envelope comprises a relatively smooth surface; and
- c) wherein the other of the sides of the envelope comprises a relatively rough surface, wherein tissue growth by the body engages the relatively rough surface after the envelope has been implanted such that the envelope is restrained from rotating and such that the relatively smooth surface may be oriented as desired within the body.

2. The breast implant according to claim 1, wherein one of the sides of the envelope is thicker than the other of the sides of the envelope, wherein the thicker side of the envelope comprises the relatively rough surface, and wherein the thinner side of the envelope comprises said relatively smooth surface.

3. The breast implant according to claim 1, wherein one of the sides of the envelope has been cured once, wherein the other side of the envelope has been cured twice, and wherein the side that has been cured once comprises said relatively smooth surface.

4. The breast implant according to claim 1, wherein the envelope is anatomically-shaped in the form of a breast and comprises front, rear, right and left sides, wherein the front, rear, right and left sides of the envelope are oriented toward the front, rear, right and left sides of the body, wherein the rear side of the anatomically-shaped envelope comprises the relatively rough surface, wherein the front side of the

envelope comprises the relatively smooth surface, and wherein each of the right and left sides comprises the relatively smooth surface.

5. The breast implant according to claim 1, wherein the envelope has a total surface area, wherein the relatively smooth surface runs over about 50% of the total surface area, and wherein the relatively rough surface runs over about 50% of the total surface area.

6. The breast implant according to claim 1, wherein the envelope includes an opening through which a mandrel had been removed, wherein the envelope is sealed with a patch engaged over the opening and to the envelope, and wherein the patch includes an exterior surface which includes the relatively rough surface.

7. A non-rotating anatomical-shaped breast implant for being implanted within a body, wherein the body includes front, rear, right and left sides, with the non-rotating anatomical-shaped breast implant comprising:

- a) an envelope formed in the anatomical shape of a breast, wherein the envelope comprises front, rear, right and left sides;
- b) wherein the envelope is fillable with fill material;
- c) wherein the front side of the envelope comprises a relatively smooth surface; and
- d) wherein the rear side of the envelope comprises a relatively rough surface, wherein tissue growth by the body engages the relatively rough surface after the implant has been implanted such that the envelope is restrained from rotating and such that the front, rear, right and left sides of the envelope remain respectively oriented toward the front, rear, right and left sides of the body.

8. The non-rotating anatomical-shaped breast implant according to claim 7, wherein the envelope includes fill material prior to the envelope being implanted.

9. A breast implant comprising:

- a) an envelope having an anterior side, posterior side, superior pole, inferior pole and a nipple position, with the nipple position being on the anterior side near the inferior pole;
- b) wherein the anterior side has a first thickness;
- c) wherein the posterior side has a second thickness; and
- d) wherein the first thickness of the anterior side is less than the second thickness of the posterior side.

10. The breast implant of claim 9 wherein the posterior side comprises a textured exterior surface portion.

11. The breast implant of claim 9 wherein the anterior side comprises a smooth exterior surface portion.

12. The breast implant of claim 9 wherein the anterior side comprises a relatively smooth exterior surface portion and wherein the posterior side comprises a relatively rough exterior surface portion.

13. The breast implant of claim 9 wherein the posterior side has been cured twice and the anterior side has been once cured.

14. The breast implant of claim 9 wherein the envelope is an anatomical-shaped breast envelope.

15. A method for minimizing rotation of a breast implant within a body, comprising the steps of:

- a) selecting a breast implant;
- b) forming a relatively rough surface on an exterior portion of the breast implant and forming a relatively smooth surface on another exterior portion of the breast implant;
- c) implanting the breast implant within the body so as to orient the relatively smooth surface in a desired direction; then
- d) permitting tissue growth to engage the relatively rough surface so as to anchor the breast implant in place, thereby minimizing rotation of the breast implant and holding the relatively smooth surface in the desired direction.

16. The method according to claim 15, wherein the step of forming the relatively rough surface comprises the step of forming a relatively rough surface over about 5% to about 50% of a total surface area of the breast implant.

17. The method according to claim 15, wherein the step of selecting a breast implant comprises the step of selecting an anatomical-shaped breast implant, wherein the anatomical-shaped breast implant comprises front, rear, right and left sides, wherein the front side of the anatomical-shaped breast implant comprises the relatively smooth surface, wherein the right side of the anatomical-shaped breast implant comprises the relatively smooth surface, wherein the left side of the anatomical-shaped breast implant comprises the relatively smooth surface, and wherein the rear side of the anatomical-shaped breast implant comprises the relatively rough surface.

18. A method of making an envelope for a breast implant, comprising the steps of:

- a) selecting a mandrel;
- b) selecting a dispersion into which the mandrel is dipped;
- c) fully submerging the mandrel in the dispersion such that an envelope is formed, withdrawing the mandrel from the dispersion and thereby picking up a first envelope layer on the mandrel, and permitting the first envelope layer to at least partially stabilize; and
- d) partially submerging the mandrel in the dispersion such that a portion of the mandrel remains exposed to the atmosphere, withdrawing the mandrel from the dispersion and thereby picking up a second envelope layer on the mandrel and permitting the second envelope layer to at least partially stabilize, whereby an envelope coating of a first thickness is disposed over one portion of the mandrel and whereby an envelope coating of a second thickness is disposed over another portion of the mandrel.

19. The method of claim 18 wherein the step of fully submerging the mandrel occurs prior to the step of partially submerging the mandrel.

20. The method of claim 18 and further comprising:

- e) curing the envelope between the steps of fully submerging the mandrel and partially submerging the mandrel; and
- f) curing the envelope after the step of partially submerging the mandrel.