



US 20080053284A1

(19) **United States**

(12) **Patent Application Publication**
Miller et al.

(10) **Pub. No.: US 2008/0053284 A1**

(43) **Pub. Date: Mar. 6, 2008**

(54) **SAWING APPARATUS AND SAW FENCE SYSTEM**

Publication Classification

(76) Inventors: **David Miller**, Tupelo, MS (US);
Robert D. Donovan, Mooreville, MS (US);
Delwyn N. Ponders, Saultillo, MS (US);
Jerry W. Ford, Plantersville, MS (US)

(51) **Int. Cl.**
B26D 7/06 (2006.01)
B23D 45/06 (2006.01)
(52) **U.S. Cl.** **83/446**

Correspondence Address:
KIRKPATRICK & LOCKHART PRESTON
GATES ELLIS LLP
535 SMITHFIELD STREET
PITTSBURGH, PA 15222 (US)

(57) **ABSTRACT**

A sawing apparatus and a saw fence. The saw apparatus may include a work surface. The saw may include a rail system disposed along the edges of the work surface, for the attachment of accessories thereto. The saw may be provided with workpiece guide adapted to be attached to the rail system for guiding workpieces during the operation of the saw. The workpiece guide may also be provided with an infeed extension that rides on the rail system and is capable of supporting workpieces during the operation of the saw. The infeed extension may be adjustable relative to the work surface of the saw. The saw may further be provided with a debris collection system for the collection of debris produced by the cutting operations of the saw.

(21) Appl. No.: **11/977,277**

(22) Filed: **Oct. 24, 2007**

Related U.S. Application Data

(63) Continuation of application No. 10/990,694, filed on Nov. 17, 2004, which is a continuation of application No. 09/134,854, filed on Aug. 14, 1998, now Pat. No. 6,899,004.

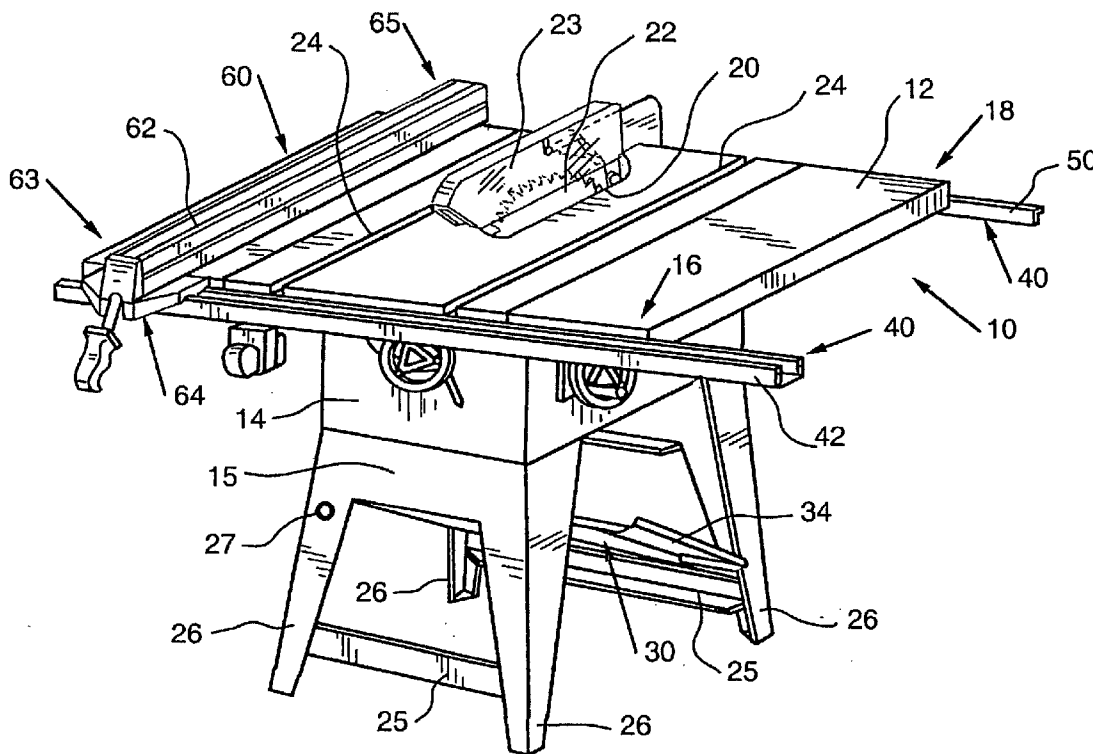

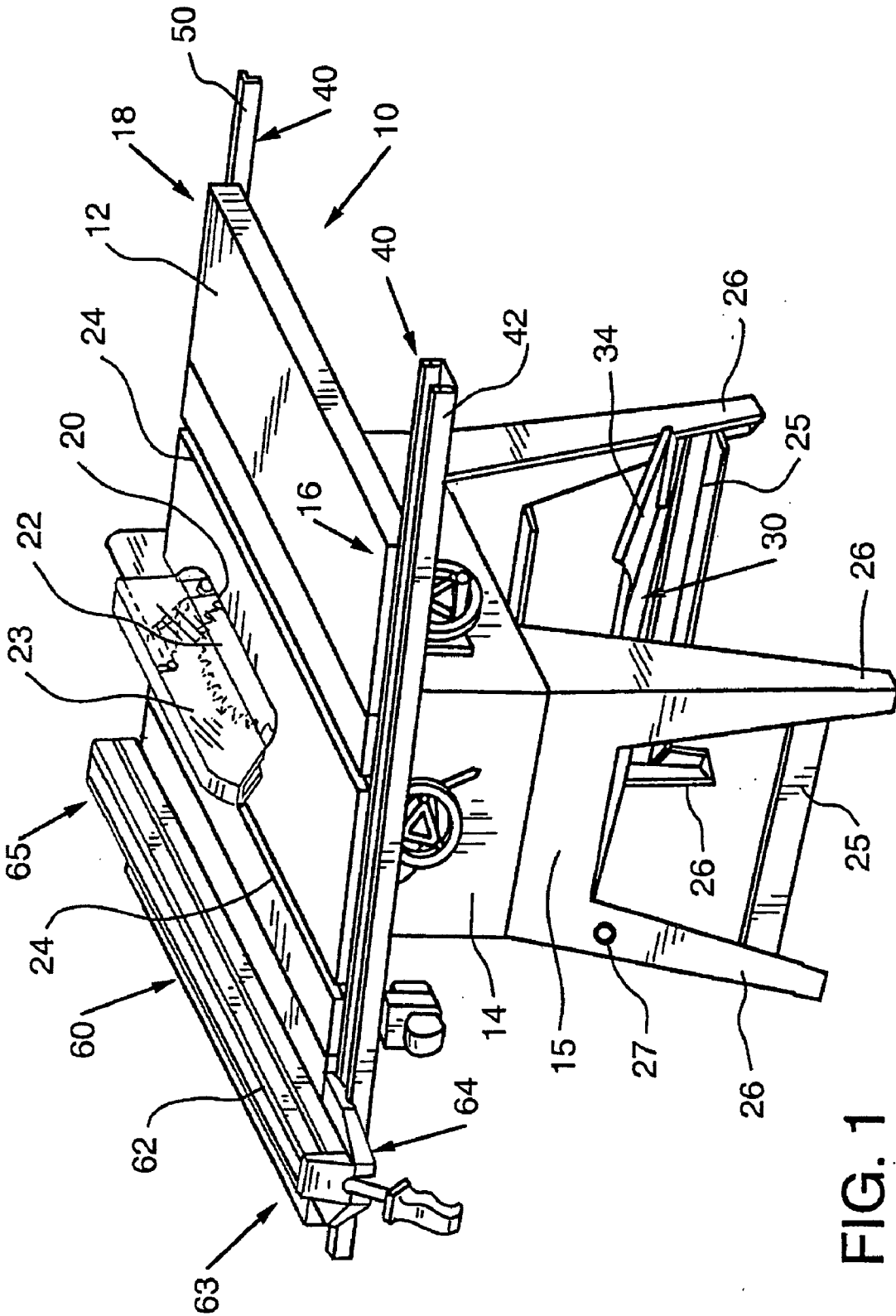

FIG. 1

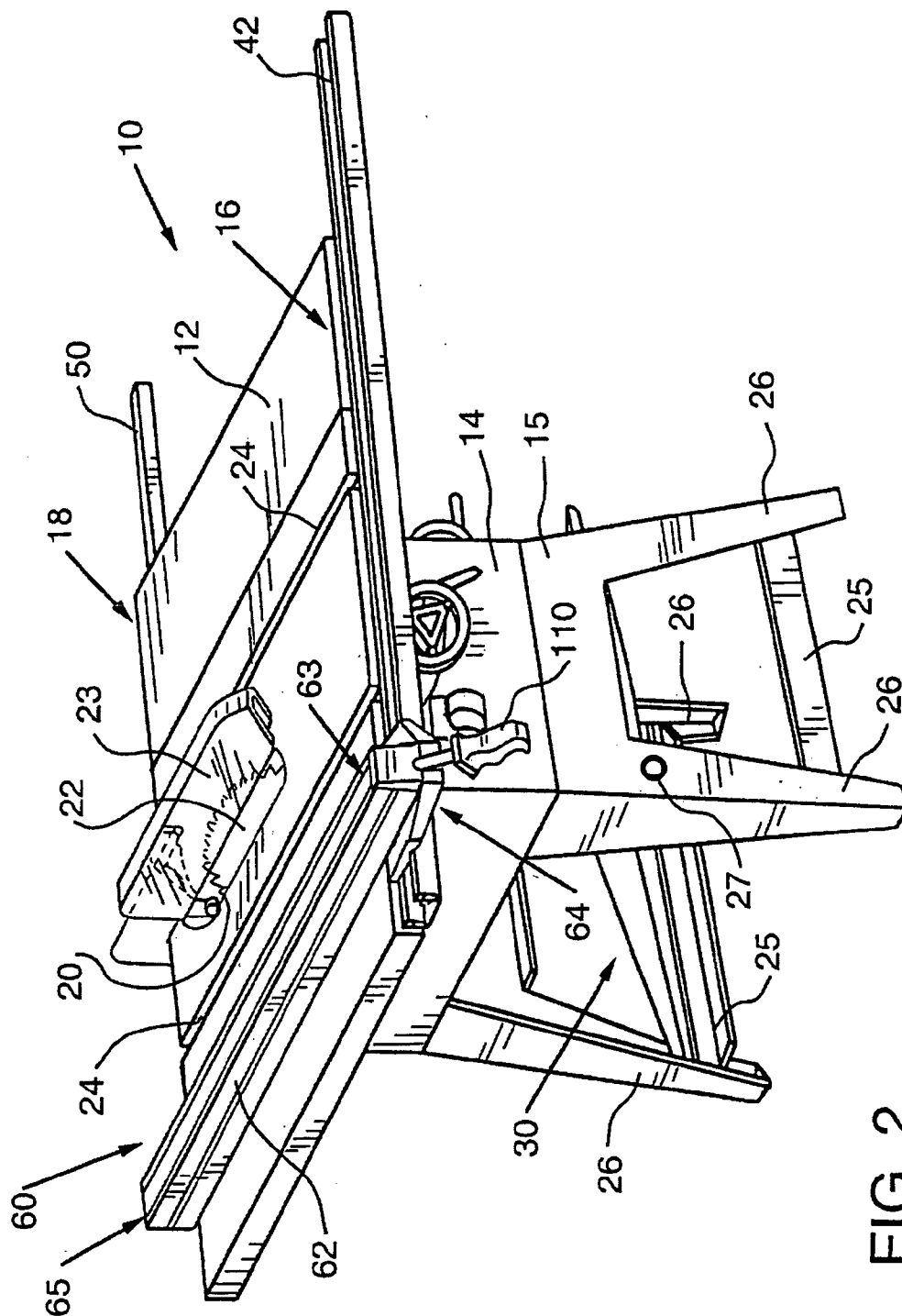

FIG. 2

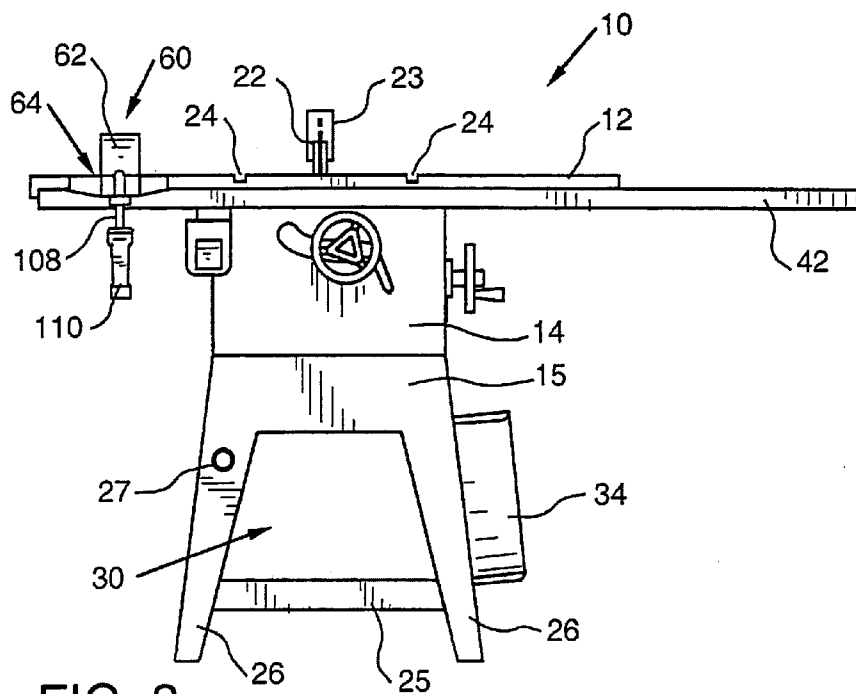

FIG. 3

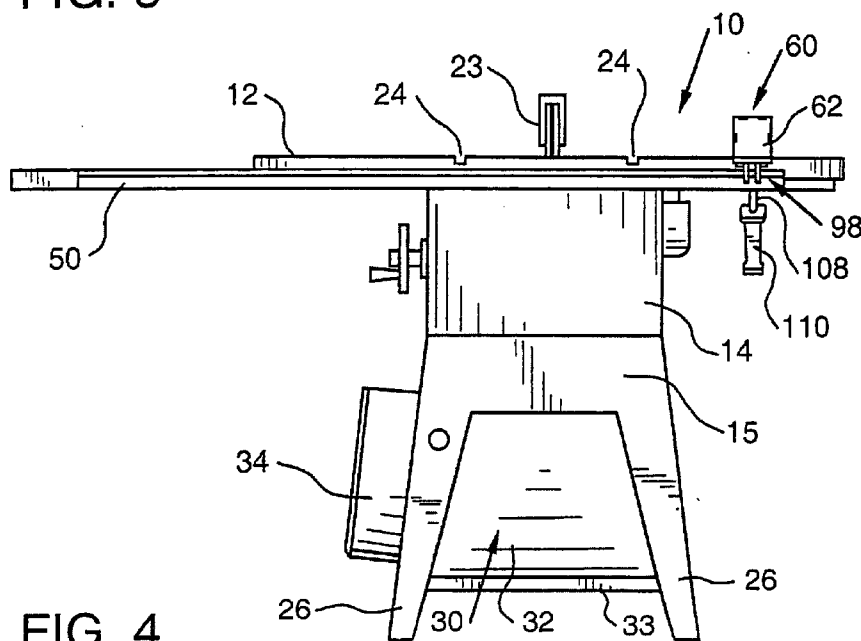

FIG. 4

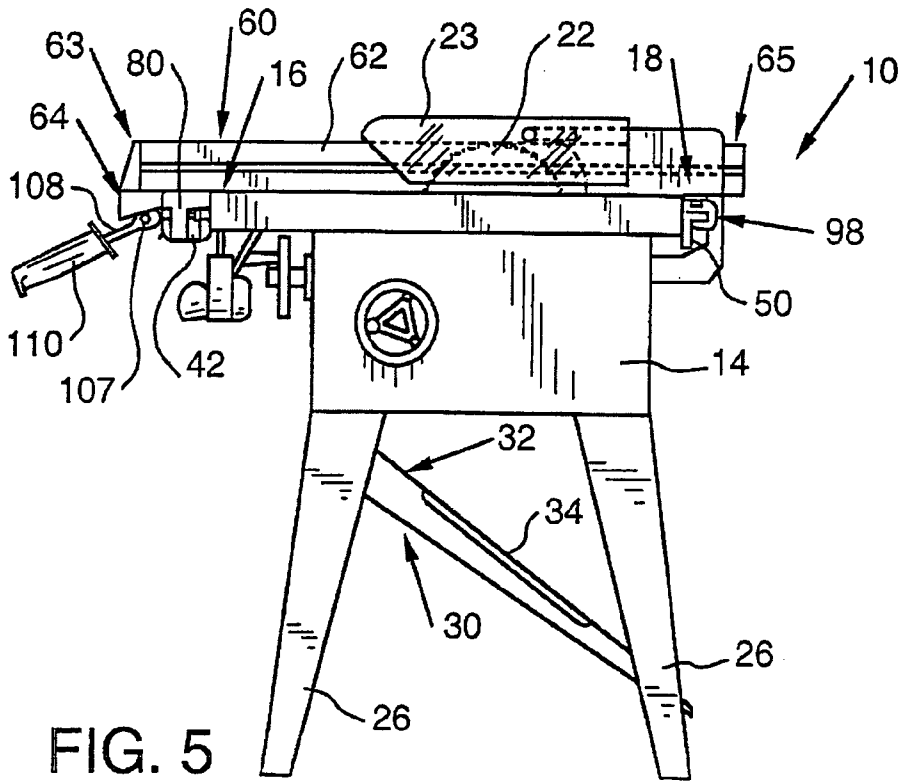

FIG. 5

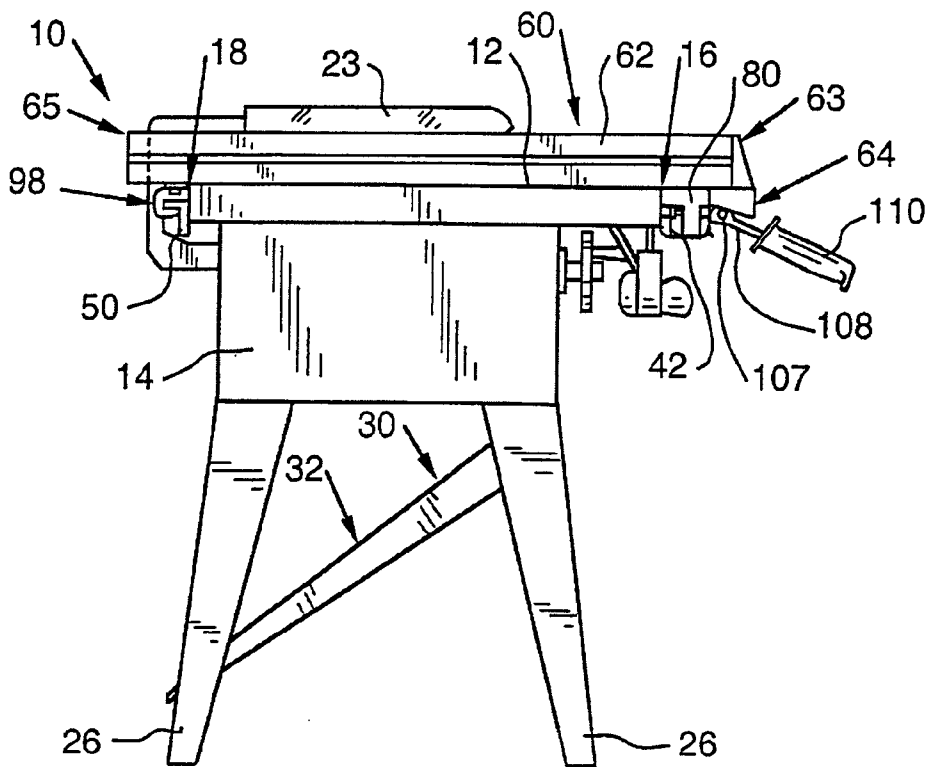

FIG. 6

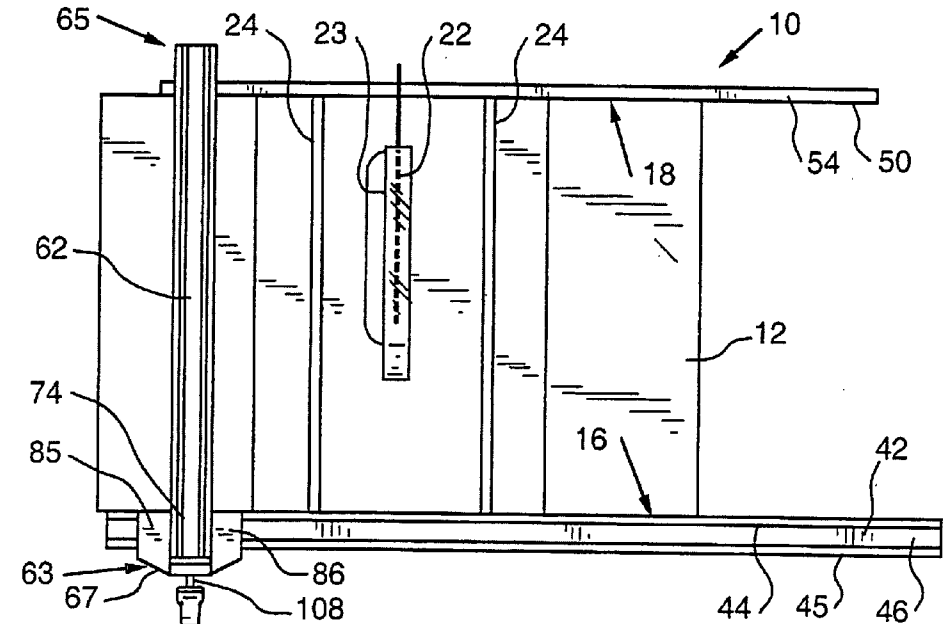

FIG. 7

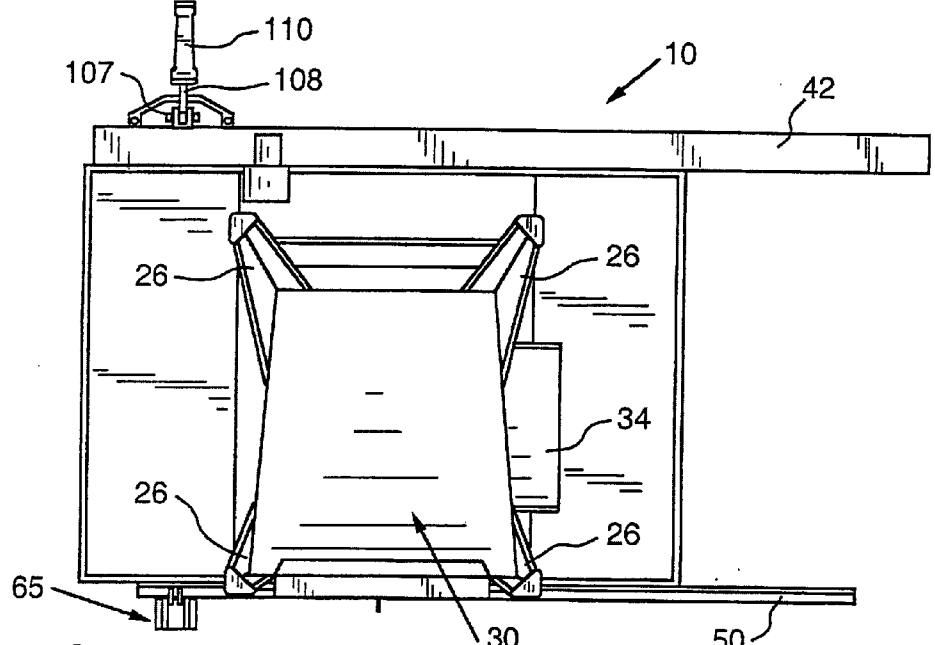

FIG. 8

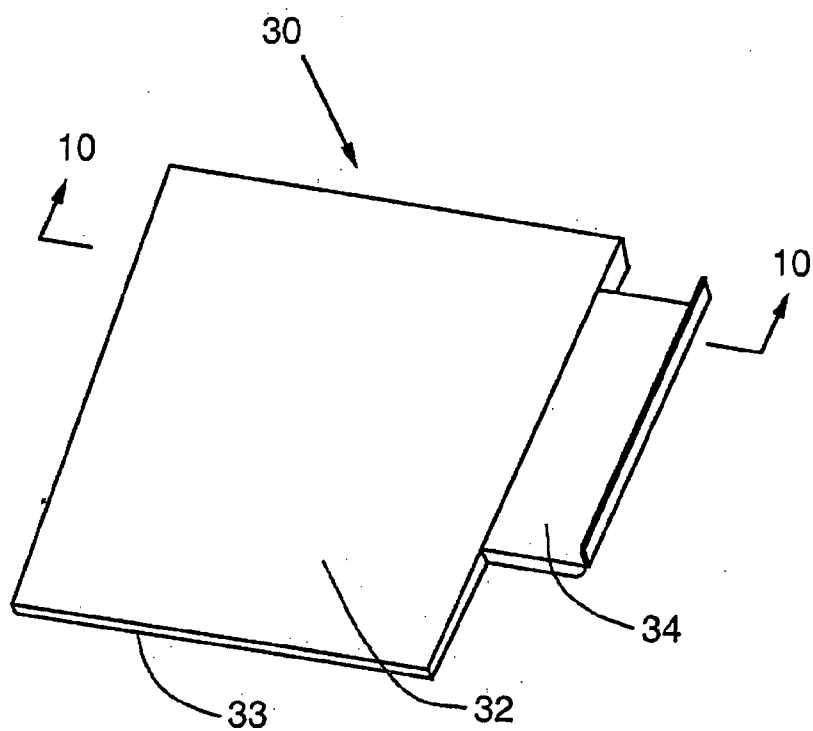

FIG. 9

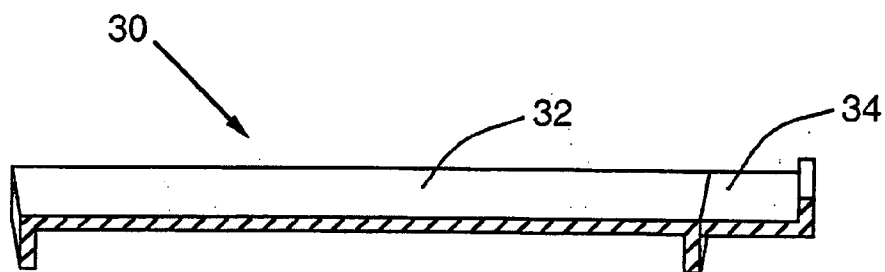

FIG. 10

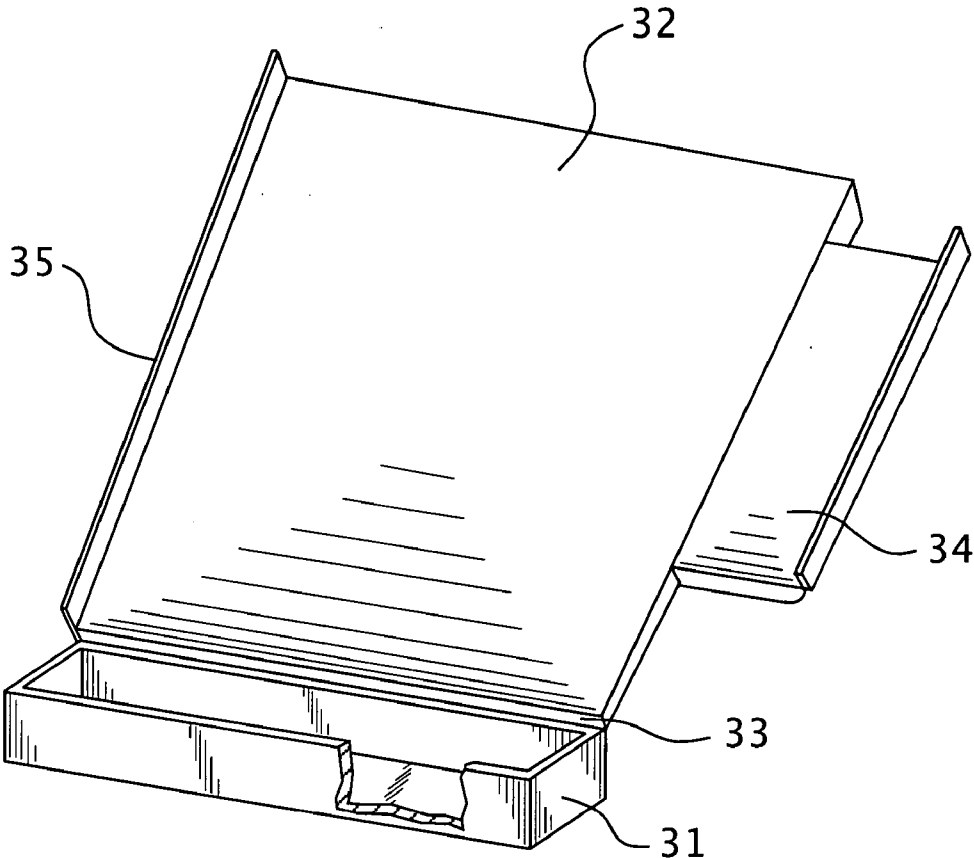

FIG. 9A

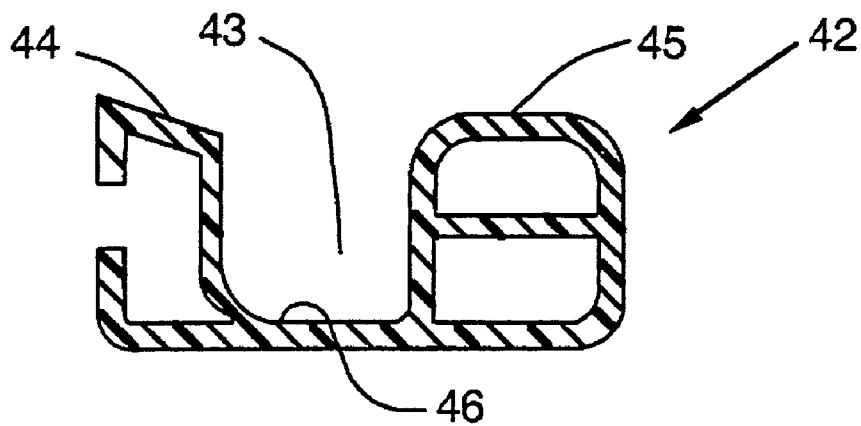

FIG. 11

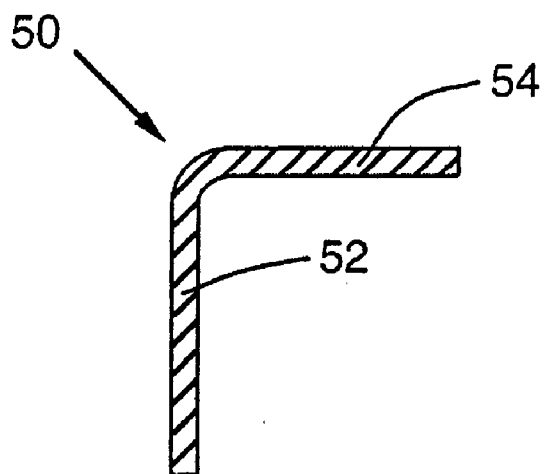

FIG. 12

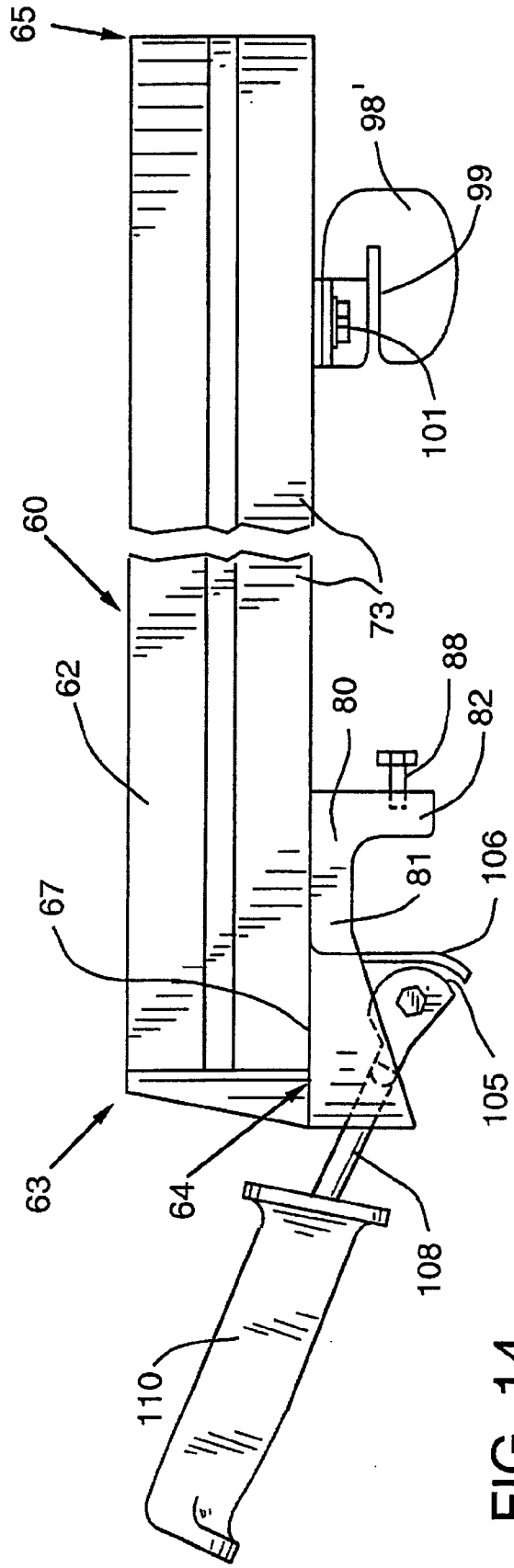
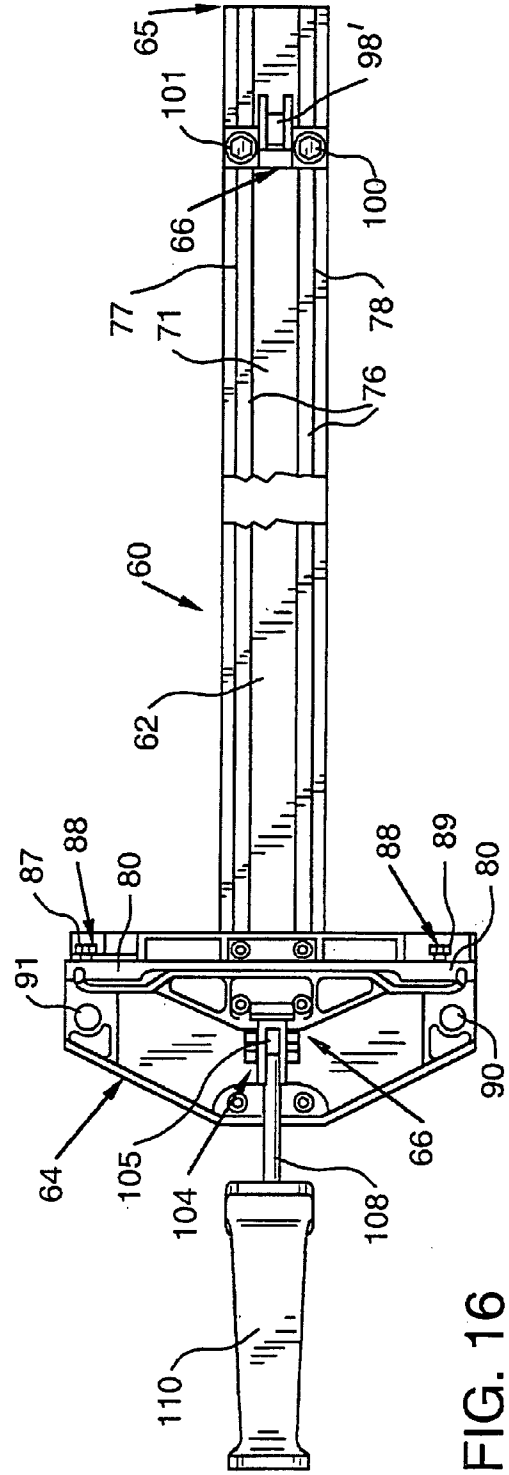
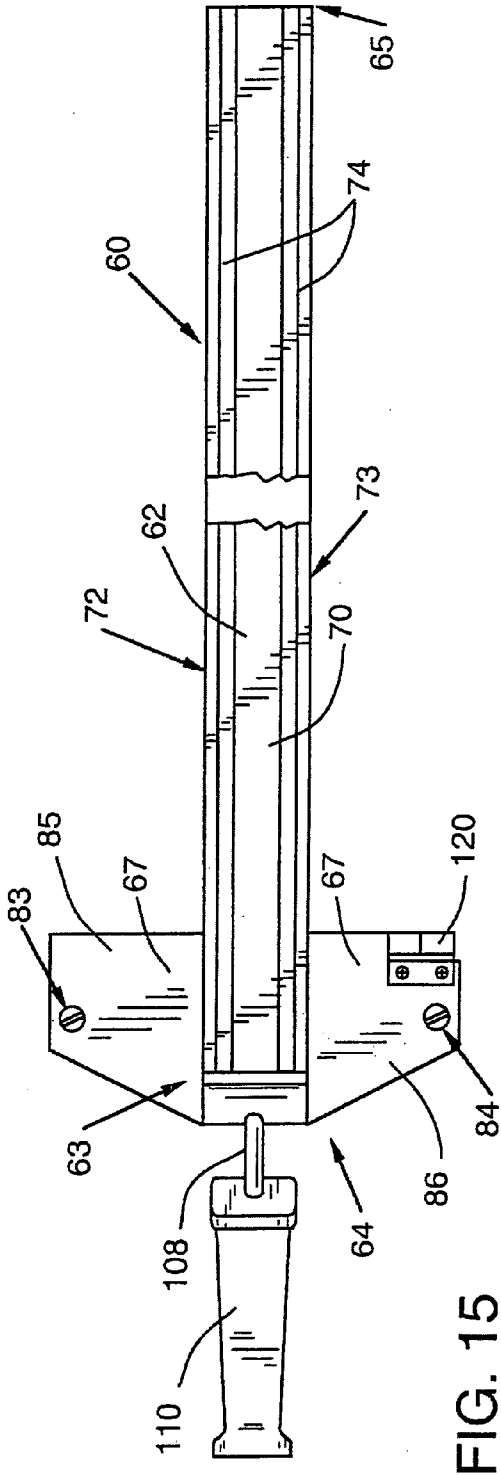
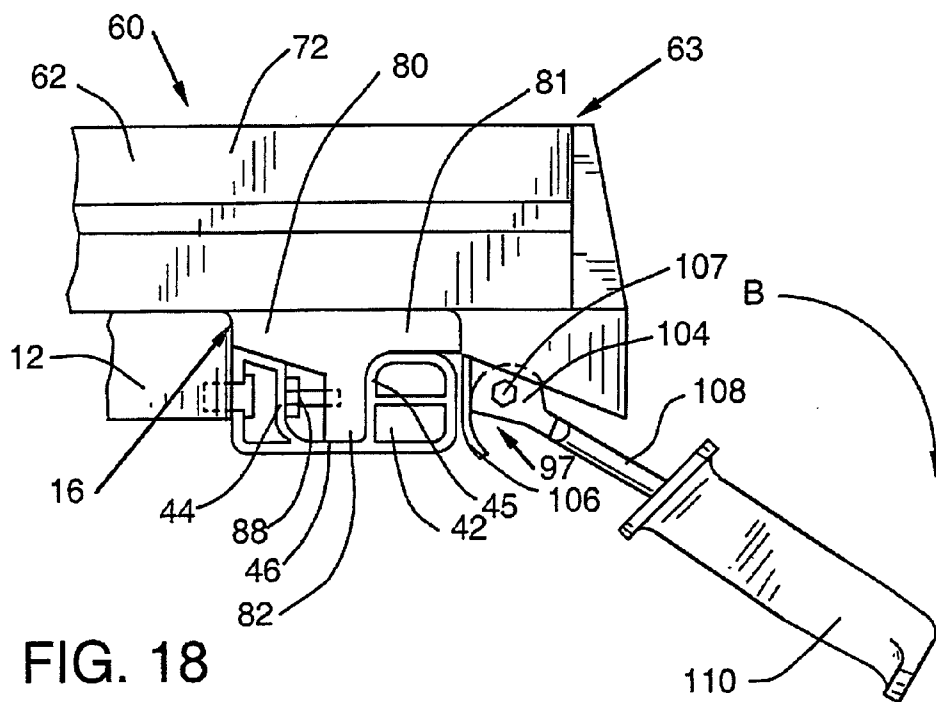
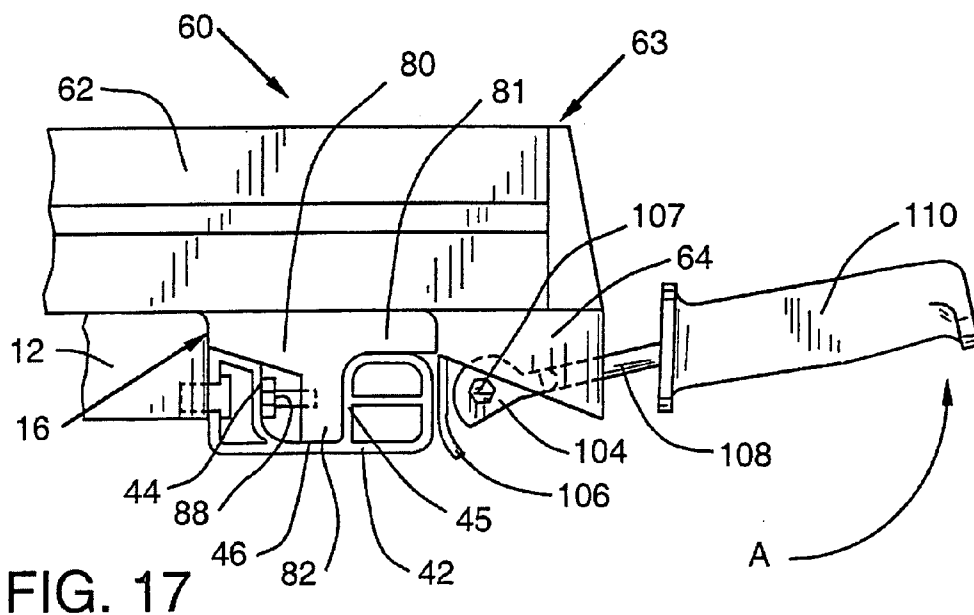

FIG. 14





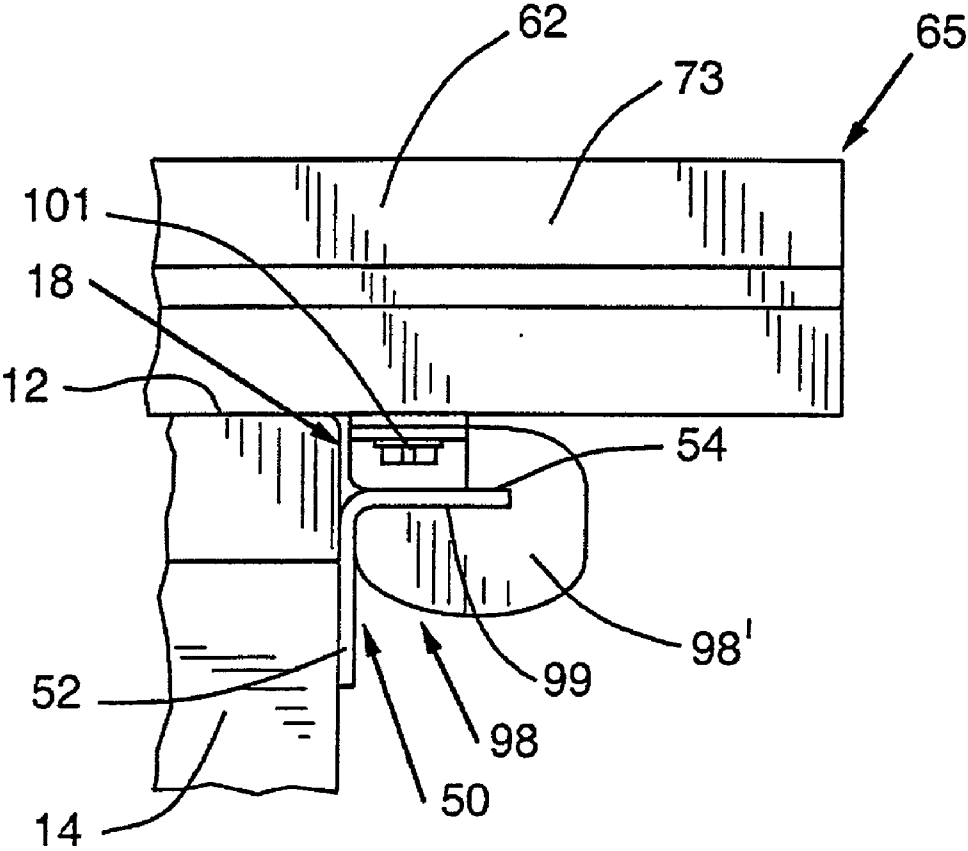

FIG. 19

**SAWING APPARATUS AND SAW FENCE SYSTEM
CROSS-REFERENCE TO RELATED
APPLICATIONS**

[0001] This non-provisional patent application is a continuation application of U.S. patent application Ser. No. 10/990,694, entitled SAWING APPARATUS AND SAW FENCE SYSTEM, which was filed on Nov. 17, 2004, which is a continuing application of U.S. patent application Ser. No. 09/134,854, entitled SAWING APPARATUS AND SAW FENCE SYSTEM, which was filed on Aug. 14, 1998 and issued as U.S. Pat. No. 6,899,004, the disclosures of which are herein incorporated by reference.

BACKGROUND OF THE INVENTION

[0002] 1. Field of the Invention

[0003] The present invention relates to sawing apparatus including a work surface for supporting a workpiece, and more particularly relates to a powered table saw including a rail system for positioning of a fence on the work surface of the saw and that may further include a dust collection system for channeling and collecting dust created during the sawing operation. The present invention also relates to a device for positioning a workpiece on the work surface of a sawing apparatus and more particularly relates to a table saw fence for positioning a workpiece on the work surface of the saw relative to the circular blade of the saw including an adjustable integral support member for at least partially supporting the workpiece when it is being advanced along the work surface of the table saw.

[0004] 2. Description of the Invention Background

[0005] Presently available workpiece fences adapted for use with powered table saws typically are not constructed so as to support the workpiece during cutting operations. In particular, the presently available table saw fences do not provide adequate and effective support to a workpiece when performing lengthwise or "rip" cuts. Predictably, individuals have sought to address this need by introducing aftermarket table saw fences that include additional elements for the purpose of supporting the workpiece during such cutting operations. However, such devices have proven to be ineffective for a number of reasons. In particular, they fail to provide consistent support to the workpiece throughout their surfaces, they generally are difficult to adjust relative to the plane of the work surface of the saw, and they may at least partially obstruct the area in front of the saw that is normally occupied by the operator.

[0006] Compounding the relative lack of utility of many of the available table saw fences is the fact that presently available table saws, and other sawing or cutting devices including work surfaces, generally do not provide convenient means for securing accessory devices, such as workpiece fences and the like, to the work surface. In particular, existing table saws employ a variety of rails and/or brackets to secure workpiece fences and other work holding and positioning accessories to the work surface. In particular, the design of commonly available table saw rails do not provide for rapid readjustment of the workpiece fence during cutting operations. In addition, the commonly available rails often require a gap between the table saw's work surface and the rail. This gap provides a channel through which objects resting on the work surface may fall or in which such objects may become trapped.

[0007] In addition, commonly available powered table saws typically lack effective means for providing for the disposal of debris produced by the cutting operations. In particular, in commonly available powered table saws, debris produced by cutting operations, for example saw dust, stock, and other scrap, falls from the work surface to the floor areas beneath and around the perimeter of the saw, thereby complicating clean up and generally lending an untidy appearance to the workshop.

[0008] Accordingly, there exists a need for a workpiece fence for a powered table saw, and other sawing devices having a work surface, which provides a conveniently adjustable means for at least partially supporting a workpiece when it is being advanced along the work surface and which does not significantly obstruct the area occupied by an operator.

[0009] There also exists a need for a sawing apparatus or other cutting including an improved rail system.

[0010] There is still another need for a saw dust/saw scrap collection system that does not allow such material to collect beneath and around the perimeter of the table saw or other sawing device.

SUMMARY OF THE INVENTION

[0011] In accordance with a particularly preferred form of the present invention, there is provided a workpiece guide for guiding and supporting workpieces during cutting operations of a cutting device having at least one rail and a work surface. In a preferred form, the workpiece guide comprises an elongate body and an infeed extension integral thereto.

[0012] Another embodiment of the present invention comprises a saw. The saw further comprises a work surface, a rail system, and a workpiece guide. The work surface comprises a substantially horizontal plane having an infeed side and an outfeed side. The rail system comprises an infeed rail disposed along the infeed side of the work surface and an outfeed rail disposed along the outfeed side of the work surface. The workpiece guide is slidably disposed on the rail system and comprises an elongated body having an infeed end and an outfeed end and an infeed extension.

[0013] Yet another embodiment of the present invention includes a saw comprising a support structure, a housing, and a debris collection system. The housing is positioned atop the support structure and comprises a cutting member adapted to cut workpieces. The debris collection system is attached to the support structure and positioned beneath the housing. The debris collection system comprises an inclined flow surface having a lower edge and at least one side edge.

[0014] The present invention also comprises a saw for cutting workpieces having a work surface and a rail system. The work surface has an infeed side and an outfeed side. The rail system comprises an infeed rail having a U-shaped cross-section disposed adjacent to the infeed side of the work surface and an outfeed rail having an L-shaped cross section disposed adjacent to the outfeed side of the work surface.

[0015] It is a feature of the present invention to provide a workpiece guide for a cutting device having a unique infeed surface that provides consistent support to a workpiece during cutting operations.

[0016] It is another feature of the present invention to provide a workpiece guide for a saw having a unique infeed surface that is easily and readily adjustable relative to the work surface of the saw.

[0017] It is yet another feature of the present invention to provide a unique workpiece guide for a saw having a work surface that does not significantly obstruct the area occupied by the operator of saw.

[0018] Yet another feature of the present invention is to provide a workpiece guide for a saw having a work surface that provides a more convenient apparatus for securing the workpiece guide to the work surface of the saw prior to cutting operations and for readjusting the workpiece guide to the work surface of the saw during cutting operations.

[0019] It is another feature of the present invention to provide an improved saw rail system for securing accessories, including a workpiece guide, to the work surface of the saw prior to cutting operations and for readjusting such accessories during cutting operations.

[0020] It is yet another feature of the present invention to provide a unique rail system for a saw that may be positioned immediately adjacent to and abutting the work surface of the saw.

[0021] It is another feature of the present invention to provide a novel debris collection system for a saw that does not allow such material to collect beneath and around the perimeter of the saw.

[0022] Accordingly, the present invention provides solutions to the shortcomings of prior sawing apparatus, workpiece guides, and debris collection systems. Those of ordinary skill in the art will readily appreciate, however, that these and other details, features and advantages will become further apparent as the following detailed description of the preferred embodiments proceeds.

BRIEF DESCRIPTION OF THE DRAWINGS

[0023] In the accompanying Figures, there are shown embodiments of the present invention wherein like reference numerals are employed to designate like parts and wherein:

[0024] FIG. 1 is a right side perspective view of an embodiment of the workpiece guide system and debris collection system of the present invention in use on a powered table saw;

[0025] FIG. 2 is a left side perspective view of the powered table saw of FIG. 1, including the workpiece guide system and debris collection system depicted in FIG. 1;

[0026] FIG. 3 is an infeed side elevational view of the powered table saw of FIG. 1, including the workpiece guide system and debris collection system depicted in FIG. 1;

[0027] FIG. 4 is an outfeed side elevational view of the powered table saw of FIG. 1, including the workpiece guide system and debris collection system depicted in FIG. 1;

[0028] FIG. 5 is a right side elevational view of the powered table saw of FIG. 1, including the workpiece guide system and debris collection system depicted in FIG. 1;

[0029] FIG. 6 is a left side elevational view of the powered table saw of FIG. 1, including the workpiece guide system and debris collection system depicted in FIG. 1;

[0030] FIG. 7 is a top view of the powered table saw of FIG. 1, including the workpiece guide system and debris collection system depicted in FIG. 1;

[0031] FIG. 8 is a bottom view of the powered table saw of FIG. 1, including the workpiece guide system and debris collection system depicted in FIG. 1;

[0032] FIG. 9 is an isometric view of the debris collection system included in FIG. 1, shown in isolation;

[0033] FIG. 9A is an isometric view of a debris collection system in accordance with an alternative embodiment of the present invention;

[0034] FIG. 10 is a side cross-sectional view of the debris collection system of FIG. 9, taken along the line 10-10 in FIG. 9;

[0035] FIG. 11 is a side cross-sectional view in isolation of the infeed rail of the workpiece guide system included in FIG. 1;

[0036] FIG. 12 is a side cross-sectional view in isolation of the outfeed rail of the workpiece guide system included in FIG. 1, in isolation;

[0037] FIG. 13 is a plan view of the workpiece guide of the workpiece guide system included in FIG. 1;

[0038] FIG. 14 is a side elevational view of the workpiece guide of FIG. 13;

[0039] FIG. 15 is a top view of the workpiece guide of FIGS. 13 and 14;

[0040] FIG. 16 is a bottom view of the workpiece guide of FIGS. 13-15;

[0041] FIG. 17 is a side view depicting the workpiece guide of FIGS. 13-16 shown positioned on the infeed rail and in the open position;

[0042] FIG. 18 is a side view depicting the workpiece guide of FIGS. 13-16 shown positioned on the infeed rail and in the clamped position; and

[0043] FIG. 19 is a side view of the means of attachment between the workpiece guide of FIGS. 13-16 and the outfeed rail.

DETAILED DESCRIPTION OF THE PREFERRED EMBODIMENTS

[0044] Referring now to the drawings for the purpose of illustrating embodiments of the inventions only and not for the purposes of limiting the same, the figures show the present inventions adopted for use in connection with a powered table saw 10. While the present inventions are particularly well-suited for use in connection with a powered table saw 10, one of ordinary skill in the art will appreciate that the present inventions may be successfully employed in connection with various other types of saws and cutting devices having workpiece support surfaces, such as miter saws, band saws, and the like. Accordingly, the protection afforded to the inventions claimed herein may not be limited solely to their use in connection with a table saw 10 of the type depicted in the present figures. Because the general mode of operations of powered table saws is well known,

only those features of the table saw **10** that are helpful in illustrating the mode of embodiments of the present inventions are discussed below.

[0045] The table saw **10** depicted in FIGS. 1-8 includes a work surface **12**, a housing **14**, and a support structure **15**. The work surface **12** includes a rectangular-shaped, generally planar surface formed from a rigid material such as steel or the like and having opposite, generally parallel infeed and outfeed edges **16** and **18**, respectively. The infeed and outfeed edges **16** and **18** have been referred to in that manner because it is typically the case that a workpiece being advanced along the work surface **12** is first advanced past the infeed edge **16** and then passes the outfeed edge **18** after exiting the circular cutting member **22**. The work surface **12** further includes a slot **20** therethrough that has a longitudinal axis that is generally perpendicular to the infeed and outfeed edges **16** and **18**. The slot **20** is adapted to allow a cutting member **22** to protrude therethrough, and the slot **20** will include an insert therein (not shown), having a shape corresponding to the portion of the cutting member **22** that protrudes through slot **20**, to at least partially prevent the passage through the work table **12** of material cut by the cutting member. In the case of table saw **10**, the cutting member **22** is a circular blade that is journaled for rotation within slot **20** about a shaft (not shown). A cutting member guard **23** is typically provided over the cutting member **22**. The work surface **12** further may include one or more channels **24** running parallel to the plane of the cutting member **22** and perpendicular to the infeed and outfeed edges **16** and **18**, and which may accept a miter gauge (not shown).

[0046] The work surface **12** is supported by and affixed atop the housing **14**. In addition to supporting the work surface **12**, the housing **14** generally provides a cavity for placement of the saw's motor and other control equipment. The housing **14** in the embodiment of table saw **10** depicted in the figures includes a supporting framework, four sides, and an open bottom. Accordingly, it will be appreciated that sawdust, cut stock, and other small debris that is produced by the cutting member **22** and falls through work surface **12** may pass through the housing **14** without becoming trapped therein.

[0047] The housing **14** is supported atop support structure **15**. The support structure **15** includes four legs **26**, formed from a rigid material such as steel or the like, and adapted and sized to support the housing **14** and work surface **12** in a generally horizontal position. The legs **26** may also include at least one storage bore **27** therethrough. The storage bore **27** is adapted to accept and store therein a variety of saw accessories when they are not in use including, for example, a miter gauge (not shown). The support structure **15** may additionally include cross-members **25** affixed amongst and between the legs **26**, using for example, bolts, screws, rivets, welds, or the like, to increase the stability and rigidity of the support structure **15**. In an alternative, the cross-members **25** and legs **26** are formed from a one-piece design by, for example, stamping.

[0048] The support structure **15** may also include a unique and novel debris collection system comprising a debris chute **30**. A preferred configuration of debris chute **30** of the present invention will now be described with reference to FIGS. 1-10. As can be seen in particular in FIGS. 1-8, the

debris chute **30** is affixed to the legs **26** and disposed immediately beneath the open bottom of the saw housing **14**. The debris chute **30** is adapted to catch any dust or other cutting debris produced by the action of the cutting member **22** that falls through the work table **12** and passes through the open bottom of housing **14**. The debris chute **30** is preferably positioned on an incline having a slope running downward in a direction generally from the infeed edge **16** toward the outfeed edge **18** of work surface **12**. Accordingly, it will be appreciated by the skilled artisan that the debris chute **30** utilizes the force of gravity to direct any debris landing thereon toward the lower edge **33** of the debris chute, which opens away from the position typically occupied by an operator. As illustrated in FIG. 9A, at least one side edge of the flow surface can further comprise at least one flange **35** integral thereto for directing debris falling thereon onto the flow surface.

[0049] As can be seen in particular in FIGS. 9 and 10, the debris chute **30** may generally include a flow surface **32** bordered along one side by a shelf **34**. The flow surface **32** may be in the form of a generally planar rectangular sheet formed of rigid material such as steel or the like, and having a smooth surface area throughout. The accessory shelf **34** includes a flange preferably formed from the same material as the flow surface **32** and is disposed along the length of one side of the flow surface **32**, integral thereto. The shelf **34** is adapted to hold saw accessories, for example, a saw fence, thereon when they are not in use. Thus, unlike conventional arrangements in which debris is allowed to fall directly onto the floor beneath the saw, it will be appreciated that the debris chute **30** is adapted to guide, or direct, debris falling onto the flow surface **32** to the lower edge **33** thereof. The lower edge **33** of debris chute **30** may additionally be provided with a debris reservoir **31** (FIG. 9A) disposed along the length thereof to collect sawdust and other debris directed to the lower edge **33**. The debris reservoir may include, for example, a box or bag adapted to catch and hold any debris traveling down the debris chute **30** and provide for improved ease in the disposal thereof. Accordingly, the debris chute **30** represents an improvement over conventional arrangements in that it restricts the area of distribution of sawdust and other cutting debris around the saw **10** and provides for increased ease of clean-up for the workshop or other location of the table saw **10**.

[0050] The table saw **10** may further include a novel rail system **40** for the attachment of accessories such as workpiece fences and other workpiece holding and positioning accessories thereto. A preferred rail system **40** of the present invention will now be described with reference to FIGS. 1-8 and 11-12. As can be seen in those Figures, the rail system **40** generally includes an infeed rail **42** and an outfeed rail **50**. The infeed rail **42** is in the form of an elongate bar, formed from a rigid material such as aluminum, steel or the like, and having a generally U-shaped cross-section throughout its length. Thus, as seen in particular in FIG. 11, the U-shaped cross-section of the infeed rail **42** defines a trough **43** having an inner arm **44**, an outer arm **45**, and a bottom **46**. Such an arrangement provides an improved selection of surfaces for clamping accessory devices such as workpiece guide **60** (the operation and construction of which will be described below) to saw **10**. The infeed rail **42** is disposed parallel to the infeed edge **16** of the work surface **12** and is fixedly connected thereto by, for example, bolts, welds, or other suitable connectors known in the art. This particularly

advantageous construction allows the infeed rail 42 to be disposed so as to directly abut infeed edge 16 of work surface 12 over its entire length such that no gap exists between infeed rail 42 and infeed edge 16. That arrangement is particularly shown in FIG. 7 and also is illustrated in FIG. 18, described in greater detail below.

[0051] In conventional rail arrangements, the infeed rail is typically a tubular member that must be positioned such that a gap exists between the rail and the work surface. Such an arrangement provides a space in which objects may become trapped and through which sawdust and other cutting debris may fall to the floor. It will be appreciated that the present rail system 40 addresses such drawbacks. As can be seen in particular in FIGS. 1-3, 7, and 8, the length of infeed rail 42 may be greater than that of the infeed edge 16 of work surface 12. Accordingly, a portion of infeed rail 42 may extend beyond the length of the infeed edge 16 of work surface 12 in order to increase the possible travel distance of accessories attached to the rail system 40.

[0052] The outfeed rail 50 of the rail system 40 includes an elongate member, formed from a rigid material such as steel, aluminum, or the like, and having a generally L-shaped cross-section throughout its length. Thus, as seen in particular in FIG. 12, the L-shaped cross-section of the outfeed rail 50 serves to define a bracket including a mounting plate 52 and a bracket plate 54 disposed in planes generally perpendicular to one another. The outfeed rail 50 is disposed parallel to the outfeed edge 18 of the work surface 12 and is fixedly mounted thereto by, for example, bolts, welds, or other suitable connectors. Such an arrangement provides improved clamping surfaces for attaching a portion of accessories, such as, for example, workpiece guide 60 (the operation and construction of which will be described below), across the work surface 12 of the table saw 10. Preferably, the outfeed rail 50 is disposed such that mounting plate 52 directly abuts the outfeed edge 18 of work surface 12 over its entire length such that no gap exists between outfeed rail 50 and outfeed edge 18. The positioning of the outfeed rail 50 in that way is indicated by, for example, FIGS. 7 and 19, the latter of which is described in greater detail below. Thus, it will be appreciated that the construction and positioning of the outfeed rail 50 may provide all or many of the same advantages derived from the construction and positioning of the infeed rail 42. The length of outfeed rail 50 may equal that of infeed rail 42, and as can be seen in particular in FIGS. 1-3, 7, and 8, the length of outfeed rail 50 may be greater length than that of outfeed edge 18 to augment the possible positioning of accessories attached to the rail system 40 relative to the cutting member 22.

[0053] As noted above, rail system 40 is conveniently adapted for use in attaching accessories to saw 10. One such accessory is workpiece guide 60 which is particularly adapted for use with the above-described embodiment of the rail system 40, and which incorporates novel features particularly adapted for positioning workpieces relative to the cutting member 22. However, although workpiece guide 60 is described herein for use in connection with rail system 40 and table saw 10, it will be appreciated that the workpiece guide 60 of the present invention may also be employed with other conventional rail systems and with cutting devices other than table saw 10. A possible construction of workpiece guide 60 will now be described with reference to

FIGS. 1-8 and 13-19. As can be seen in particular in FIGS. 13-19, the workpiece guide 60 is adapted to be positioned atop work surface 12 and to span the length thereof in a substantially parallel relation to the plane of cutting member 22. Workpiece guide 60 is further adapted to selectively engage and slidingly ride on rail system 40. Workpiece guide or fence 60 generally includes a fence body or body 62, an infeed extension 64, and an attachment mechanism 66. The body 62 generally includes an elongate member, formed from a rigid material such as steel, aluminum, or the like, and having an infeed end 63 and an outfeed end 65. The length of body 62 is preferably greater than the width of the table saw 10 (defined herein as the distance between the infeed rail 42 and outfeed rail 50) such that the body 62 will overhang and extend beyond infeed rail 42 and outfeed rail 50.

[0054] The body 62 has rectangular cross-section which serves to define a hollow interior region 68 having a top surface 70, a bottom surface 71, and side faces 72 and 73. Preferably, the top surface 70 additionally includes one or more slots 74 therein. The slots 74 preferably include channels, having a T-shaped cross-section, and spanning the length of body 62. The T-shaped cross-section of the slots 74 is adapted to accept various saw accessories including, for example, fingerboards, push sticks, and other accessories as are known in the art. (See FIG. 13) The side faces 72 and 73 include smooth surfaces positioned generally perpendicular to the plane of top and bottom surfaces 70 and 71, respectively, and adapted to allow workpieces to slide therealong. The bottom surface 71 preferably includes a pair of slots 76 disposed thereon and running the length thereof. The pair of slots 76 preferably include two channels 77 and 78 having T-shaped cross-sections and adapted to accept attachment mechanism 66 therein. (See FIG. 16) The construction and operation of attachment mechanism 66 will be further described further below.

[0055] The present workpiece guide 60 also includes a unique and novel infeed extension 64, the construction and operation of which will now be described. The infeed extension 64 generally includes a delta-shaped work supporting surface 67 portion, integral to the body 62, and formed from a rigid material such as aluminum, steel or the like. (See FIGS. 13, 15, and 16) The work supporting surface 67 of the infeed extension 64 is oriented beneath body 62 at the infeed end 63 thereof. Accordingly, the infeed extension 64 serves to define two infeed platforms 85 and 86 positioned adjacent to side faces 72 and 73 of body 62, respectively, and which may be positioned so that the work supporting surface 67 is generally coplanar with work surface 12 when workpiece guide 60 is mounted on saw 10. The infeed extension 64 is further adapted to abut infeed edge 16 of work surface 12 and to form a protrusion therefrom extending beyond infeed rail 42, generally in the direction of the operator. (See FIGS. 1, 2, and 7) The infeed extension 64 may also include an indicator 120 in the surface thereof for reading witness lines (not shown) on the infeed rail 42 so as to indicate the distance between the side faces 72 and 73 of the body 62 and the cutting member 22. The infeed extension 64 may support workpieces that are being advanced into the cutting member 22 and that extend beyond the infeed edge 16 of the work surface 12. It will thus be appreciated that the inclusion of infeed extension 64 on workpiece guide 60 represents an improvement over the

prior art in that it provides for increased support of workpieces being fed into the saw 10 during, for example, rip-cutting operations.

[0056] Preferably, workpiece guide 60 further includes support elements adapted to support infeed extension 64 on infeed rail 42. In the embodiment shown in the FIGS. 15-19, the support elements include an elongated bracket member 80 which is adapted to slidably support infeed extension 64 and workpiece guide 60 on infeed rail 42. In one embodiment, bracket member 80 is an L-shaped bracket member defined by arms 81 and 82 running transverse to body 62 beneath infeed extension 64 and adapted to slidably engage infeed rail 42. The relationship of those elements is indicated in, for example, FIGS. 14, 17, and 19. In particular, when the workpiece fence 60 is positioned on table saw 10, arm 81 is oriented generally parallel with the surface of infeed extension 64 and is adapted to sit atop outer arm 45 of infeed rail 42. Arm 82 is oriented generally perpendicular to the surface of infeed extension 64 and is adapted to be slidably seated within trough 43 abutting outer arm 45, as is generally shown in FIGS. 17 and 18. Arm 82 may additionally include lateral adjustment mechanism 88 protruding therefrom in the direction of inner arm 44 of infeed rail 42. Lateral adjustment mechanism 88 includes threaded members 87 and 89. See FIG. 16. The threaded members 87 and 89 may include bolts, screws, or the like that are seated within threaded bores (not shown) in the surface of arm 82. Accordingly, it will be appreciated that threaded members 87 and 89 may be selectively adjusted within the threaded bores (not shown) to seat against inner arm 44 and thereby increase the contact pressure within the trough 43 between bracket member 80 and infeed rail 42. Such construction allows for adjustment of the force required to slide the fence 60 along infeed rail 42. Such construction also increases the stability of the fence 60 within infeed rail 42. Accordingly, such construction of the fence 60 and infeed rail 42 provides consistent support to workpieces placed thereon.

[0057] The present infeed extension 64 further includes height adjustment mechanisms 83 and 84 adapted to adjustably support infeed extension 64 on infeed rail 42 within trough 43. The height adjustment mechanisms 83 and 84 are adapted to adjust the height of infeed extension 64 relative to work surface 12 and to allow the work supporting surface 67 of infeed extension 64 to be adjusted so as to be generally coplanar with work surface 12. Accordingly, height adjustment mechanisms 83 and 84 include bases 90 and 91 mounted to each infeed platform 85 and 86, respectively, by a threaded member 93 and 94, respectively, as indicated in FIG. 13. Threaded members 93 and 94 may be, for example, screws, bolts, or other suitable members characterized by a threaded shaft having a head at one end and a base 90 and 91 is secured to the threaded end of each threaded member 93 and 94, respectively. Threaded members 93 and 94 are mounted in threaded bores 95 and 96, respectively, positioned along the edge of infeed platforms 85 and 86, respectively. Bases 90 and 91 are adapted to be seated atop infeed rail 42. The heads of threaded members 93 and 94 are preferably adapted for actuation by conventional means such as a screw driver, allen wrench, or the like, and are recessed within threaded bores 95 and 96 such that they do not protrude from the work supporting surface 67 of the infeed platforms 85 and 86. Accordingly, it will be understood that rotation of the threaded members 93 and 94 within the threaded bores 95 and 96 will cause infeed platforms 85 and

86, respectively, to be raised or lowered relative to infeed rail 42. It will further be appreciated that the threaded members 93 and 94 may be independently adjusted within threaded bores 95 and 96, respectively, to independently adjust the height of the infeed platforms 85 and 86, respectively. The present infeed extension 64 thus represents an improvement over the prior art because it is fully supported on infeed rail 42 and does not obstruct the area normally occupied by the operator, and also is easily adjustable during use.

[0058] Workpiece guide 60 further includes attachment mechanism 66 adapted to releasably secure the workpiece guide 60 to the rail system 40. While the workpiece guide 60 depicted and described herein is particularly adapted to be used with rail system 40, it will be appreciated that the workpiece guide 60 of the present invention may be adapted for use with a variety of conventional rail systems as well. As shown in particular in FIGS. 13-19, the attachment mechanism 66 includes an infeed rail attachment mechanism 97 and an outfeed rail attachment mechanism 98. The outfeed rail attachment mechanism 98 includes a bracket 98' formed from a rigid material such as steel or the like, defining a slot 99 adapted to accept bracket plate 54 of outfeed rail 50 therein, as is shown in FIG. 19. Accordingly, it will be appreciated that the outfeed rail attachment mechanism 98 is adapted to prevent the fence 60 from lifting off of the work surface 12 during use and maintains the fence 60 in a parallel relation to the plane of cutting member 22. The outfeed rail attachment mechanism 98 is slidably attached to body 62 by fasteners 100 and 101, which are seated within slots 76 on the bottom 71 of body 62 and are adapted to anchor the outfeed rail attachment mechanism 98 to body 62. Accordingly, the fasteners 100 and 101 are adapted to fit within the T-shaped cross-section of slots 76 and may be positioned and secured at a selected location along the length thereof. Fasteners preferably include threaded nuts disposed within the slots 76 and bolts or screws running through mounting plate 52 threaded therethrough. Thus, it will be appreciated that fasteners 100 and 101 may be selectively tightened to fixedly clamp the outfeed rail attachment mechanism 98 at any point along the length of the body 62 and may be loosened to provide for free movement of outfeed rail attachment mechanism 98 along the length of body 62. Accordingly, such construction allows workpiece guide 60 of the present invention to be adjusted to fit cutting devices having work surfaces of various sizes.

[0059] Infeed rail attachment mechanism 97 includes a clamp 104, a clamp plate 106, and a lever 108. As shown in particular in FIGS. 17 and 18, the clamp 104 includes a cam-shaped surface 105 thereon. Clamp 104 is journaled to body 62 beneath infeed extension 64 at the infeed end 63 of the body 62 so that it may rotate about a shaft 107. Clamp plate 106 is in the form of a curved plate, formed from a rigid material such as steel, and having an inner surface that generally corresponds to cam-shaped surface 105 of clamp 104. As indicated in FIG. 17, the clamp plate 106 is at least partially disposed between clamp 104 and infeed rail 42 when the workpiece guide 60 is positioned on the rail system 40. The cam further include lever 108 integral thereto. Lever 108 includes a shaft, which may include a handle 110 at the end thereof, and that is adapted to rotate clamp 104 about shaft 107. Lever 108 and clamp 104 are preferably formed from a single unitary piece of rigid material, such as steel or the like, such that lever 108 protrudes therefrom and may be

conveniently manipulated by an operator. However, lever 108 may alternatively be formed from a separate piece of material that is threadedly or otherwise connected to clamp 104.

[0060] The infeed rail attachment mechanism 97 may be reciprocated between either of a clamped position, shown in FIG. 18, or an open position, shown in FIG. 17, by the lever 108. As indicated in FIG. 18, by rotating the lever 108 downward in the direction indicated by the arrow B in that figure, the surface 105 of clamp 104 is brought into contact with a surface of clamp plate 106 and biases the clamp plate 106 into contact with the infeed rail 42, thereby securing the workpiece guide 60 on the rail system 40 at a desired location. To unsecure the workpiece guide 60, the lever 108 is rotated about shaft 107 in the direction indicated by the arrow A of FIG. 17, thereby moving surface 105 of clamp 104 out of engagement with clamp plate 106 to release the clamping force between clamp plate 106 and infeed rail 42. Accordingly, infeed rail attachment mechanism 97 represents an improvement in that it allows for improved ease of adjustment of workpiece guide 60. In particular, when lever 108 is in the unclamped position, as shown in FIG. 17, surface 105 of clamp 104 is not in contact with clamp plate 106 and thus no clamping pressure is being exerted on the outer arm 45 of infeed rail 42 by infeed rail attachment mechanism 97. In this position, fence 60 is free to slide along the length of rail system 40. When lever 108 is actuated into the clamped position, as shown in FIG. 18, clamp plate 106 is forced into frictional contact against outer arm 45 of infeed rail 42, and workpiece guide 60 is locked in place along the length of rail system 40.

[0061] As can be appreciated from the above description, the workpiece guide and debris collection system of the present invention provide distinct advantages over conventional designs. For example, the workpiece guide provides a consistent and solid infeed surface without obstructing the operator's work space. The infeed surface provides for the improved support of workpieces during, for example, rip-cutting operations. The workpiece guide adjustment features provide for height adjustment and leveling of the infeed surface. The infeed surface's integral arrangement with the body of the fence further increases the ease with which the workpiece guide may be adjusted. The fence rail system of the present invention also provides advantages over prior fence rail systems. For example, the present fence rail system incorporates improved clamping surfaces and thus provides for improved ease of attachment of accessories thereto. Those of ordinary skill in the art will, of course, appreciate that various changes in the details, materials and arrangement of parts which have been herein described and illustrated in order to explain the nature of the invention may be made by the skilled artisan within the principle and scope of the invention as expressed in the appended claims.

What is claimed is:

1. A workpiece guide for guiding and supporting workpieces during cutting operations of a cutting device comprising at least one rail and a work surface, said workpiece guide comprising:

- an elongated body;
- an infeed extension integral to said elongated body, wherein said elongated body comprises an infeed end and an outfeed end and further comprises two parallel

side walls and top and bottom walls, said infeed extension integral to said infeed end of said elongated body and comprising an infeed platform adjacent to each of said two side walls, each said infeed platform including a workpiece supporting surface, said infeed extension being adjustable on the rail to position said workpiece supporting surfaces substantially coplanar with the work surface when the workpiece guide is mounted on the cutting device; and

a clamp positionable adjacent to the at least one rail, for attaching said workpiece guide to the at least one rail.

2. A saw comprising:

a work surface comprising a substantially horizontal plane including an infeed edge and an outfeed edge;

a rail system comprising an infeed rail disposed along said infeed edge and an outfeed rail disposed along said outfeed edge;

a workpiece guide slidably disposed on said rail system comprising an elongated body and an infeed extension, wherein said elongated body comprises an infeed end and an outfeed end and further comprises two side walls oriented perpendicular to the work surface, said infeed extension integral to said infeed end of said body and comprising an infeed platform adjacent to each of said two side walls, each said infeed platform including a workpiece supporting surface, said infeed extension being adjustable on said infeed rail to position said workpiece supporting surfaces substantially coplanar with said horizontal plane of said work surface; and

a clamp positioned adjacent to said infeed rail, for fixedly clamping said workpiece guide to said infeed rail.

3. A saw comprising:

a support structure;

a housing positioned atop said support structure and comprising a cutting member adapted to cut workpieces;

a debris collection system attached to said support structure positioned beneath said housing and comprising an inclined flow surface including a lower edge and at least one side edge;

a work surface attached atop said housing comprising a substantially horizontal plane including an infeed edge and an outfeed edge;

a guide rail system comprising an infeed rail disposed along said infeed edge and an outfeed rail disposed along said outfeed edge; and

a workpiece guide slidably disposed on said guide rail system comprising an elongated body and an infeed extension, said elongated body comprising an infeed end and an outfeed end, wherein said elongated body further comprises two side walls oriented perpendicular to the work surface, said infeed extension integral to said infeed end of said body and comprising an infeed platform adjacent to each of said two side walls, each said infeed platform including a workpiece supporting surface, said infeed extension being adjustable on said infeed rail to position said workpiece supporting surfaces substantially coplanar with said horizontal plane of said work surface, said workpiece guide further

comprising a clamp positioned adjacent to said infeed rail, for clamping said workpiece guide to said infeed rail.

4. A saw for cutting workpieces the saw comprising a work surface including an infeed edge and an outfeed edge, the saw comprising:

a guide rail system comprising an infeed rail having a U-shaped cross-section disposed adjacent to said infeed edge of said work surface, and an outfeed rail having an L-shaped cross-section and disposed adjacent to said outfeed edge of said work surface; and

a workpiece guide slidably disposed on said guide rail system comprising an elongated body and an infeed

extension, said elongated body comprising an infeed end and an outfeed end, wherein said elongated body further comprises two side walls oriented perpendicular to the work surface, said infeed extension integral to said infeed end of said body and comprising infeed platforms adjacent to each of said two side walls and a clamp positioned adjacent to said infeed rail, for clamping said workpiece guide to said infeed rail, each said infeed platform including a workpiece supporting surface, said infeed extension being adjustable on said infeed rail to position said workpiece supporting surfaces substantially coplanar with said work surface.

* * * * *